

# CHAPTER 6

## High Performance Cooling for Power Electronics

In many instances, standard finned aluminium heat sinks, even with fan assistance, cannot achieve the required cooling performance due to physical limitations in heat transfer capabilities, namely the limited thermal conductivity of air for convection and copper and aluminium for conduction.

Figure 6.1 shows a comparison of various cooling techniques as a function of the attainable heat transfer in terms of the heat transfer coefficient,  $h$ . For example, using equation 5.4, to accommodate a heat flux of  $100\text{W}/\text{cm}^2$  at a temperature difference of  $50\text{K}$  requires an effective heat transfer coefficient (including a possible area enlarging factor) of  $20\text{kW}/\text{m}^2\text{K}$  ( $h = 100\text{W}/\text{cm}^2/50\text{K}$ ). From Figure 6.1 it can be concluded that liquid cooling can play an important role in thermal management.

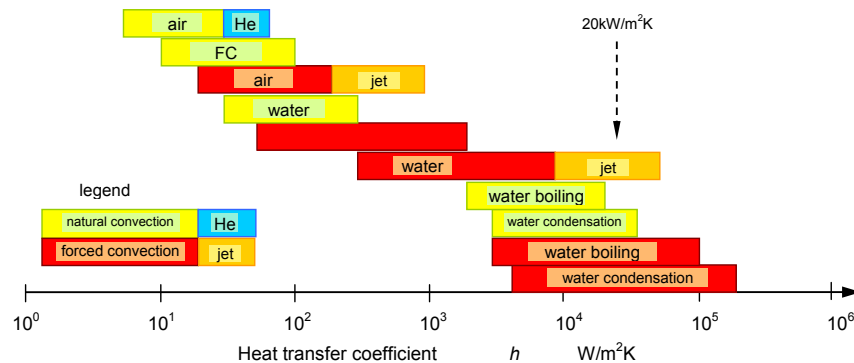

Figure 6.1. Heat transfer coefficient  $h$  attainable with natural convection, single-phase liquid forced convection, and boiling for different coolants. (see figure 6.33)

### 6.1 Conduction and heat spreading

In all power electronic cooling applications, heat from the device sources must be transmitted via thermal conduction to the surfaces exposed to the cooling fluid before it can be rejected to the coolant. As shown in Figure 6.2, heat must be conducted from the die to the  $\text{Al}_2\text{O}_3$  substrate and Cu base plate to the heat sink before it can be rejected to the flowing air. A thermal interface material (TIM) may be used to facilitate thermal conduction from the die to the base plate and from the base plate to the heat sink. In power electronics, heat spreaders (heat sinks without any cooling fins and less bulky structures) in the form of a flat plate with good thermal conductivity may be interposed between the die mounted substrate and heatsink, to facilitate spreading of the heat from its small source. Vapour chambers are also used to spread heat from a concentrated die or module heat source to a larger heat sink.

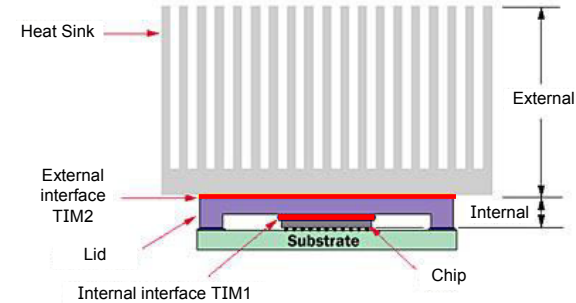

Figure 6.2. Power semiconductor package with thermal conduction path to heat sink via TIMs.

For high-power applications, the interface thermal resistance becomes an important constraint. Direct soldering (for example, reflow soldering) is often difficult, particularly when copper is used because of the large co-efficient of thermal expansion CTE mismatch between Cu and  $\text{Al}_2\text{O}_3$  and in turn, Si. Diamond-filled greases have an effective thermal conductivity of over  $20\text{W}/\text{mK}$ . Also possible is a nanostructured foil, which utilizes a fast exothermic reaction to create a soldered connection virtually at room temperature.

Heat spreading is an effective method of mitigating the need for complicated high-heat flux cooling options. To be effective the benefits of decreasing the heat flux density by increasing the area should outweigh the penalty of adding another thermal layer through which the heat must conduct. Other than a traditional copper heat spreading base plate, the alternative is to use advanced heat spreading materials such as carbonaceous materials, metal-matrix composites, ceramic matrix composites (for example, diamond-particle-reinforced silicon carbide), or ScD (Skeleton cemented Diamond), all with higher thermal conductivities than copper, are much lighter, and have tuneable CTEs.

By employing heat spreaders, cooling methods such as loop heat pipes and low-flow liquid cooling may be augmented to accommodate higher heat flux applications. Figure 6.3a shows heat spreading results for a  $300\text{W}$  heat source of  $2\text{cm}^2$  area as a function of thermal conductivity  $\lambda$ , thickness  $t$ , and cooling boundary condition (that is, heat transfer coefficient  $h$ ). Heat spreading is a complex phenomenon because the conduction and convection effects cannot be separated and the two effects compete: increasing the thickness increases the through-plane thermal resistance but decreases the in-plane thermal resistance. For example, comparing the two upper curves with the two lower curves, their order is changed. The figure also shows that heat spreaders can be used to decrease the required fluid-side heat transfer coefficient to manageable values, below  $5\text{kW}/\text{m}^2\text{K}$ , which can be realized with hydrofluoroether (HFE) cooling fluids. For example, using an  $8 \times 8 = 64\text{cm}^2$  heat spreader of an advanced composite with a thermal conductivity  $\lambda$  of  $800\text{W}/\text{mK}$  and a thickness  $t$  of  $4\text{mm}$  results in a temperature rise of  $40^\circ\text{C}$  with a heat transfer coefficient  $h$  of  $2500\text{W}/\text{m}^2\text{K}$ .

For a single heat energy source, minimal thermal gain results from a Cu base plate thickness in excess of  $6\text{mm}$ . In the case of power IGBT modules, this boundary is complicated by the fact that many heat sources, die, are adjacently bonded to a given copper coated ceramic substrate, which is then bonded to a Cu spreader base plate.

The relative heat spreading resistance for varying spreader thicknesses in aluminium, copper, silver, and Cusil ( $72\%\text{Ag}+28\%\text{Cu}$ ) is shown in figure 6.3b. Aluminium is extensively used (also for air-cooled heat sinks) even though its relative thermal conductivity is the poorest of the materials shown, because of its:

- lowest cost
- ease of fabrication
- performance adequacy

6.2 Heat-sinks

Heat sinks are devices that enhance heat dissipation from a hot surface, usually the case of a heat-generating component, to a cooler ambient, usually air. Air is assumed to be the cooling fluid. In most situations, heat transfer across the interface between the solid surface and the coolant air is the least efficient within the system, and the solid-air interface represents the greatest barrier to heat dissipation. A heat sink lowers this barrier by increasing the surface area that is in direct contact with the coolant. This allows more heat to be dissipated and/or lowers the device operating temperature. The primary purpose of a heat sink is to maintain the device junction temperature below the maximum allowable temperature specified by the device manufacturer.

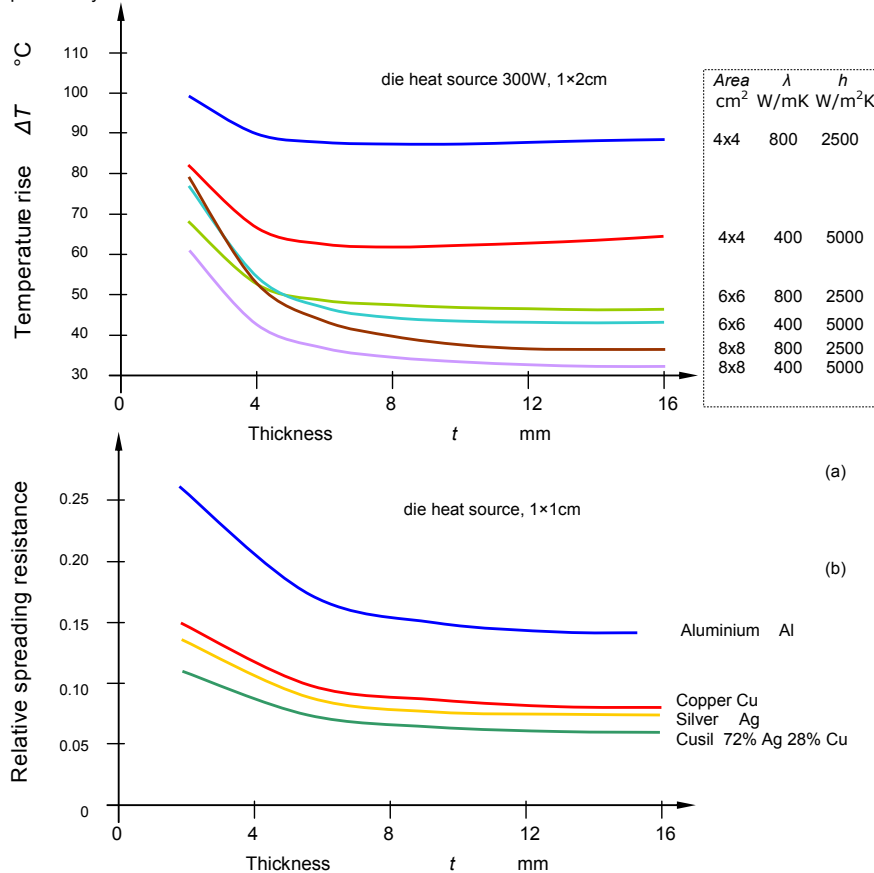

Figure 6.3. Example of effect of thickness of heat spreader for various: (a) heat source areas, material thermal conductivities, and heat transfer coefficients and (b) material and resultant relative heat spreading resistance.

6.2.1 Required heat-sink thermal resistance

To begin the heat sink selection, the heat sink thermal resistance required to satisfy the thermal criteria of the component is determined. By rearranging equation 5.11 into terms of the ambient temperature  $T_a$ , the heat sink resistance is obtained as

$$R_{jS-a} = \frac{T_j - T_a}{P_d} - R_{j-c} - R_{c-s} \quad \left[ = \frac{1}{mc_\rho} \times \frac{1}{1 - e^{-\frac{hA}{mc_\rho}}} = \frac{1}{mc_\rho} \times \frac{1}{\eta_v} \right] \quad (6.1)$$

where  $T_j$ ,  $P_d$  and  $R_{j-c}$  are provided by the device manufacturer, and  $T_a$  and  $R_{c-s}$  are user-defined parameters.

The ambient air temperature  $T_a$  for cooling electronic equipment depends on the operating environment in which the component is used. Typically, it ranges from 35 to 45°C, if external air is used, and from 50 to 60°C, if the component is enclosed or in the wake of another heat-generating component.

6.2.2 Heat-sink selection

In selecting an appropriate heat sink that meets the required thermal criteria, it is necessary to examine various parameters that affect not only the heat sink performance itself, but also the overall performance of the system. The choice of a particular heat sink type depends largely on the thermal budget allowed for the heat sink and external conditions surrounding the heat sink. There is not a single thermal resistance value assigned to a given heat sink, since thermal resistance varies with external cooling conditions.

When selecting a heat sink, it is necessary to classify the airflow as natural, low flow mixed, or high flow forced convection. Natural convection occurs when there is no externally induced flow and heat transfer relies solely on the free buoyant flow of air surrounding the heat sink. Forced convection occurs when the flow of air is induced by mechanical means, usually a fan or blower. There is no clear distinction on the flow velocity that separates the mixed and forced flow regimes. Generally the effect of buoyant force on the overall heat transfer diminishes to a negligible level (under 5%) when the induced airflow velocity excess 1 to 2m/s.

Next, the required volume of a heat sink is determined. Table 6.1 shows approximate ranges of volumetric thermal resistance of a typical heat sink under different flow conditions.

Table 6.1: Range of volumetric thermal resistance

flow condition m/s	volumetric resistance $cm^3$ °C/W
natural convection	500-800
1.0	150-250
2.5	80-150
5.0	50-80

The heat sink volume for a given low flow condition is obtained by dividing the volumetric thermal resistance by the required thermal resistance. Table 6.1 is used only as a guide for estimation purposes at the beginning of the selection process. The actual resistance values may vary outside the shown range depending on additional parameters, such as actual dimensions of the heat sink, type of the heat sink, flow configuration, orientation, surface finish, altitude, etc. The lower values shown correspond to a heat sink volume from approximately 100 to 200cm<sup>3</sup> up to about 1000cm<sup>3</sup>.

The tabulated ranges in Table 6.1 assume that the design has been optimized for a given flow condition. Although there are many parameters to be considered in optimizing a heat sink, one of the most critical parameters is the fin density. In a planar fin heat sink, optimum fin spacing is mainly related to two parameters: flow velocity and fin length  $H$  in the direction of the flow, as shown in Table 5.5.

It is beneficial to increase the width of a heat sink rather than its length. Also, the effect of radiation heat transfer is important in natural convection, as it can be responsible for up to 30% of the total heat dissipation. As the ambient temperature rises the heatsink temperature increases for a constant thermal power loading, and the heatsink thermal resistance decreases due to the increased significance of thermal radiation ( $T^4$  dependence in equation 5.1) in the heat removal process. As the ambient temperature decreases the heatsink thermal resistance decreases slightly.

Unless the component is facing a hotter surface nearby, it is imperative to have the heat sink surfaces suitably 'black' painted or anodized to enhance radiation.

6.2.3 Heat sink types

Heat sinks separate into three broad categories:

- Plate-fin – suitable for general straight airflow;
- Pin-fin – suitable for omni-directional airflow; and
- Foam-fin – suitable for ducted airflow with a high pressure drop.

Heat sinks can be classified in terms of manufacturing methods and their final form shapes. Conventional heat sink manufacturing methods involve extruding and die-casting.

The most common types of air-cooled heat sinks are summarised in Table 6.2 and include:

**Extruded fins:**

Extrusion is a process in which a solid block is converted into a continuous length of uniform cross-section by forcing it to flow under high pressure through a die orifice, which is so shaped, as to impart the required form to the product. Typically, billets of aluminium are placed within a strong walled enclosure and are caused to extrude through the die under a high pressure exerted by a ram, actuated hydraulically or mechanically. Extrusion is the most widely used method for heat sink manufacture.

This process allows the formation of elaborate two-dimensional shapes capable of dissipating large heat loads. They may be cut, machined, and coated. Cross-cutting will produce omni-directional, rectangular pin fin heat sinks, and incorporating serrated fins improves the performance by approximately 10 to 20%, but with a slower extrusion rate. Extrusion limits, such as the fin height-to-gap fin thickness,  $L/s$ , usually dictate the flexibility in design options (see figure 5.4). Typical fin height-to-gap aspect ratio  $L/s$  of up to 6 and a minimum fin thickness  $t$  of 1.3mm, are attainable with a standard extrusion. A 10 to 1 aspect ratio  $W/L$  and a fin thickness  $t$  of 20mm can be achieved with special die design features. However, as the aspect ratio increases, the extrusion tolerance is compromised.

**Casted fins:**

In the die-casting method, molten metal is forced under pressure into metal dies or moulds to produce accurately dimensioned parts. It is the fastest of all casting processes and is often employed where rapidity and economy in production are essential. The thermal conductivity of cast heat sinks may be worsened by porosity caused by gases evolving during solidification.

Sand, lost core, and die casting processes are available with or without vacuum assistance, in aluminium or copper/bronze. This technology is used in high-density pin fin heat sinks which provide maximum performance when using impingement cooling.

**Modified die-casted fins:**

The modified die-casting process involves the extension of basic die-casting principles, whereby the base of the heat sink is die-cast around a fixtured array of extremely thin stamped fins. The fins are separated by spacers, which prevent the die-cast material from flowing into the fin-to-fin spacing. Aluminium is the most commonly used material for this technique. The absence of a so-called interface between the fins and the base eliminates the impact of an interface resistance. This process allows much higher aspect ratios while fulfilling the requirement of small inter-fin spacing. These heat sinks are usually combined with a heat pipe to provide an effective thermal solution.

**Bonded/fabricated fins:**

Bonded heat sinks are often built-up extrusions, typically manufactured by assembling extruded plates into slots or grooves on an extruded or machined heat sink base plate, and held in place by an interface, usually a two part thermosetting thermally conductive aluminium-filled epoxy or a solder. However, the bonding agent presents a thermal barrier. These heat sinks are often costlier to manufacture, and the base typically requires special machining. Process limitations are usually related to the strength of the bonding agent and dimensional constraints for the slot in the heat sink base. Hybrid heat sinks utilizing different materials for the fins and the base are possible. Bonded fin arrays are most commonly rectangular plate fin arrays.

Most air-cooled heat sinks are convection limited, and the overall thermal performance of an air-cooled heat sink can be improved if more surface area can be exposed to the air stream. The bonding process allows for a much greater fin height-to-gap aspect ratio  $L/s$  of 20 to 40, greatly increasing the cooling capacity without increasing volume requirements.

**Forged/stamped fins:**

In *forged heat sinks*, the fin arrays are formed by forcing raw material into a moulding die using a punch. A common problem in forging is the choking of material in the moulding die cavity, which leads to fins of uneven height. Aluminium and magnesium alloys are readily forged, and an important economic advantage is a typically low rejection rate for the process.

Some of the attractive benefits of forging include high strength, superior surface finish, structural rigidity, close tolerance capabilities, continuity of shape, and high uniformity of material.

Copper or aluminium sheet metals are *stamped* into desired shapes. They are used in traditional air-cooling of electronic components and offer a low cost solution to low density thermal problems. They are suitable for high volume production, because advanced tooling with high-speed stamping lowers costs. Additional labour-saving options, such as taps, clips, and interface materials, can be factory applied to help to reduce the assembly costs.

**Folded/convoluted fins:**

Folded heat sinks are built-up sheet metal, manufactured by folding sheet metal into a serpentine fin array. The folded metal sheets are attached to the base of the heat sink by soldering or brazing, which results in

additional thermal resistance at that interface. This contact resistance is small, due to the fact that the 'bends' of folded fins are typically flattened while bonding or brazing, thus increasing the contact surface area. Difficulty in achieving smaller fin pitches required to construct dense arrays is a common issue. Similar to the bonding process, this manufacturing method allows flexibility in designing hybrid heat sinks made up of a combination of different materials.

Alternatively, corrugated sheet metal of either aluminium or copper increases surface area, hence, the volumetric performance. The heat sink is then attached either to a base plate or directly to the heating surface via epoxying or brazing. It is not suitable for high profile heat sinks because of the availability and fin efficiency.

**Skived fins:**

In the skiving process, fins are machined using special tooling, whereby precisely sliced layers from an extruded metal block are bent at the base of the slice to form slender curved fins. Since the fins and base are an integral unit, the interface resistance found in folded and bonded heat sinks is absent. Aluminium 6063 is the preferred material because of its superior machinability and strength, but copper arrays are also available. The depth of cut determines the fin thickness and can result in extremely thin fin structures, yielding light and competitive heat sink designs.

**Machined fins:**

Heat sinks are machined out of a metal block by material removal to create the inter-fin spaces. Most commonly, they are manufactured by gang saw cutting on a computer numerical control machine. The gang saw consists of multiple saw cutters on an arbour with precise spacing, which depends on the heat sink geometry to be machined. Fins damaged and distorted during processing require extensive secondary operations. Material is also consumed in an unproductive manner by the generation of scrap swarf metal.

**Swaged fins:**

Individual fins are placed in a pre-grooved base, and then rollers swage the sides of the fins to maintain them in place.

**Table 6.2: Feature of different types of heatsinks**

Heatsink fin type	Applications	Thermal resistance	Advantages	Disadvantages
extruded	most applications	varies	versatile	limited size
die-casted	low power	high	expensive	low thermal conductivity, expensive die charge
bonded	large applications	high	close tolerances	expensive
single-fin fabricated assembly	all application	very low	light weight and low profile with high degree of flow	expensive
forged	most applications	moderate	inexpensive	limited in design and flow management
stamped	low power	high	inexpensive	low performance
convoluted (folded) fin	ducted air	high at low flows low at high flows	high heat flux density	expensive, needs ducting
skived	most applications	moderate	close tolerances	thick base, high weight, orientation sensitive
machined	prototypes	design dependant	quickly produced	high aspect ratio fins difficult to machine – inconsistent fin geometry
swaged	high power	medium	suitable for power devices	heavy and bulky, limited availability for flow management

**6.2.4 Heatsink fin geometry**

Figure 6.4, showing the nomenclature of the array geometry, including the fin height,  $L$ , fin thickness,  $t$ , inter-fin spacing,  $s$ , width of base,  $W$ , and the length of the heat sink base,  $H$ .

Figure 6.5 shows the results of thermal resistance calculations for an aluminium heat sink (0.1x0.1m heat sink base; fin height,  $L=0.05m$ ), in forced air convection for flow conditions of 20Pa and  $0.01m^3/s$ . The

thermal resistance is defined as the ratio of the excess temperature difference in °C to the heat dissipation rate in W, where the excess temperature difference is between the bottom surface of the heat sink base and the incoming air at the heat sink inlet. It is assumed that such a flow condition is defined by a pressure drop and flow rate representing a single point on a fan characteristic curve.

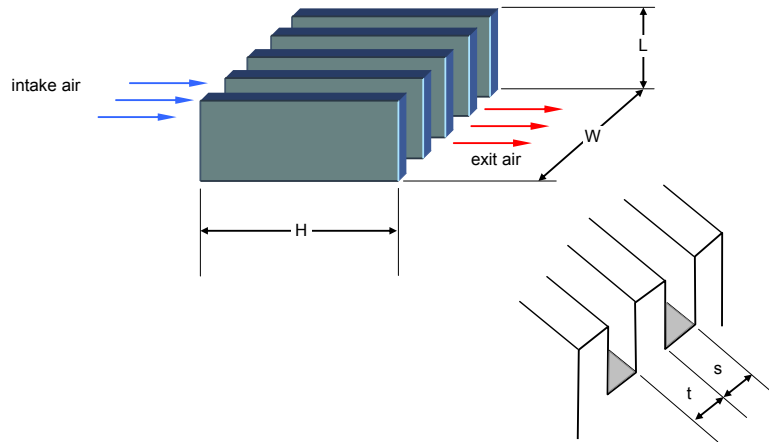

Figure 6.4. Geometry of the plate fin heat sink analysed.

For each value of fin density, there is a corresponding fin-to-fin spacing, *s*, and fin thickness, *t*, which meets the pressure drop requirement at the specified flow rate. Increasing fin number decreases both the fin thickness and the spacing. For a given thermal operating condition, described by pressure drop and volumetric flow rate, designs with particularly small and relatively large fin densities yield high values of thermal resistance, the former due to limited surface area and the latter caused by the highly inefficient thin fins. An intermediate geometry, which minimizes the thermal resistance, can thus be identified, where the thermal optimization illustrated in Figure 6.5 uses a heat sink volume as the driving thermal constraint and not an actual application specification.

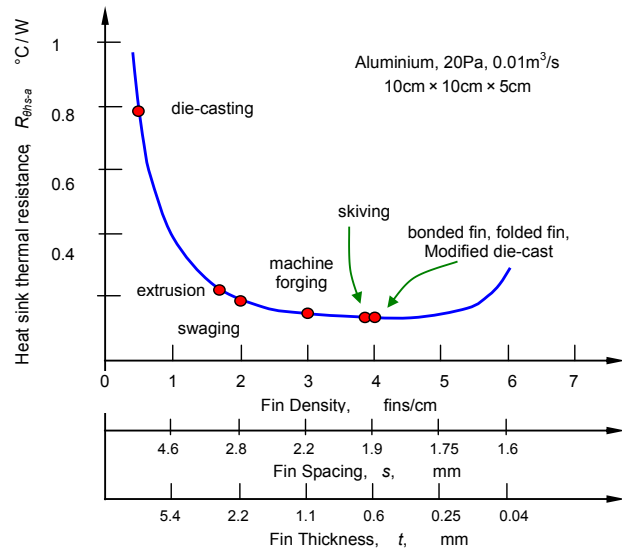

Figure 6.5. Typical thermal characteristic plot for a heat sink: Thermal Resistance versus Fin Density, 0.1m x 0.1m, 0.05m, Aluminium, 20Pa, 0.01m<sup>3</sup>/s.

Table 6.3: Process capabilities for different manufacturing techniques

Parameter (see figure 5.4)	Conventional Processes		Modern Processes					
	Extruded	Die-Casting	Bonding	Folding	Modified Die-Casting	Forging	Skiving	Machining
min <i>t</i> , mm	1	1.75	0.75	0.25	0.2	0.4	0.3	0.5
max <i>L</i> / <i>s</i>	8:1	6:1	60:1	40:1	20:1	50:1	25:1	50:1
min <i>s</i> , mm	6.6	8.3	0.8	1.25	0.2	1	2	1
Material	Al	Al, Zn-Alloy	Al, Cu, Mg	Al, Cu	Al, Zn-Alloy	Al	Al	Al, Cu, Mg

For the conditions illustrated in Figure 6.5, a minimum value of 0.135°C/W occurs at 4 fins/cm, yielding a design that will dissipate 186W at a 25°C excess temperature from the base to the inlet air. The fin thickness and spacing for this aluminium structure are 0.57mm and 1.93mm, respectively with a heat sink mass of 0.308kg. In Table 6.3, not all the processes are capable of creating a heat sink with such dimensions with a gap aspect ratio of 26 and a fin aspect ratio of 86.

Figure 6.6 shows the typical range of cost functions for different types of heat sinks in terms of required thermal resistance *R<sub>θ</sub>*.

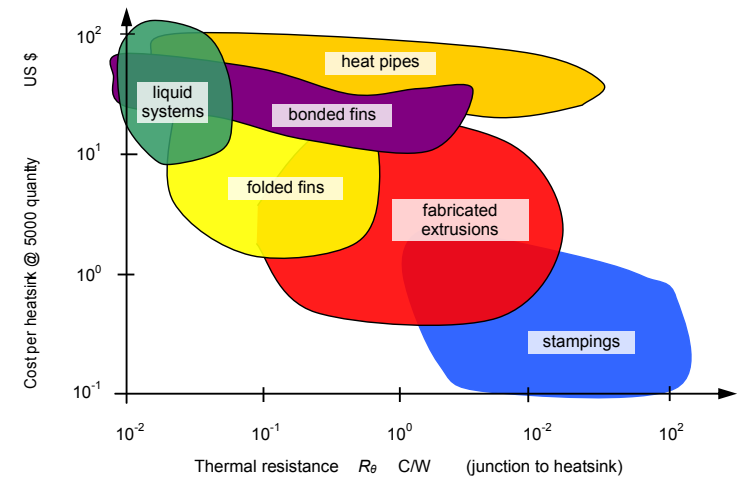

Figure 6.6. Cost versus required thermal resistance.

The performance of different heat sink types varies dramatically with the airflow across the surface area of the heat sink. To quantify the effectiveness of different types of heat sinks, the volumetric heat transfer efficiency is defined as

$$\eta_v = \frac{P_d}{m_f c_p \Delta T_{sa}} \tag{6.2}$$

where *m<sub>f</sub>* is the mass flow rate through the heat sink, *c<sub>p</sub>* is the heat capacity of the fluid, and  $\Delta T_{sa}$  is the average temperature difference between the heat sink and the ambient air. The heat transfer efficiencies for a wide range of heat sink configurations, and their ranges are listed in Table 6.4. The improved thermal performance is associated with additional costs in either material or manufacturing, or both.

Table 6.4: Range of heat transfer efficiencies

Heat sink type	$\eta_v$ range %
Stamping & flat plates	10-18
Finned extrusions	15-22
Impingement flow Fan heat sinks	25-32
Fully ducted extrusions	45-58
Ducted pin fin, Bonded and folded fins	78-90

### 6.2.5 Thermal performance graph

Typical heat sink performance graphs are shown in figure 6.7. It is assumed that the device to be cooled is correctly mounted, and the heat sink is in its normal mounting orientation with respect to the direction of airflow. The solid plot is the natural convection curve of heat sink temperature rise,  $\Delta T_{sa}$ , versus  $P_D$ , which assumes that the heat sink is appropriately painted or anodized black. The dashed curve is the forced convection curve of thermal resistance versus air velocity. In forced convection,  $\Delta T_{sa}$  is linearly proportional to  $P_D$ , hence  $R_{sa}$  is independent of  $P_D$  and becomes a function only of the flow velocity. However, the natural convection phenomenon is non-linear, making it necessary to present  $\Delta T_{sa}$  as a function of  $P_D$ .

The performance graphs can be used to identify the heat sink and, for forced convection applications, to determine the minimum flow velocity that satisfy the thermal requirements. For example, if the required thermal resistance in a force convection application is  $8^\circ\text{C/W}$ , the thermal resistance versus flow velocity curve indicates a velocity of at least  $2.4\text{m/s}$  ( $480\text{lfm}$ ). For natural convection applications, the required thermal resistance  $R_{sa}$  can be multiplied by  $P_D$  to yield the maximum allowable  $\Delta T_{sa}$ . The temperature rise of a chosen heat sink must be equal to or less than the maximum allowable  $\Delta T_{sa}$  at the same  $P_D$ .

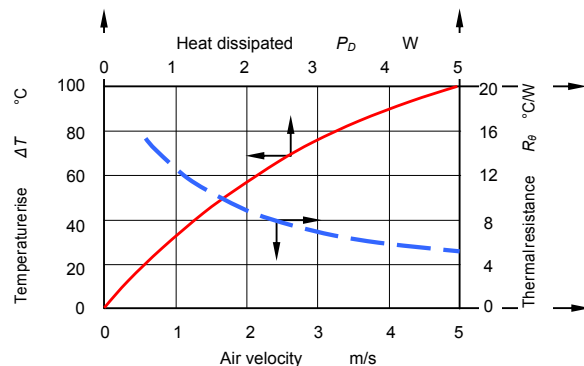

Figure 6.7. Typical finned heatsink thermal performance graphs.

The natural convection curves assume an optimal orientation of the heat sink with respect to gravity. Also, the flow velocity in the forced convection graph represents the approach flow velocity without accounting for the effect of flow bypass. Flow bypass reduces the performance of a heat sink by as much as 50% for the same upstream flow velocity.

When a device is substantially smaller than the base plate of a heat sink, the thermal spreading resistance needs to be considered in the selection process. Performance graphs generally assume that the heat is evenly distributed over the entire base area of the heat sink, and therefore, do not account for the additional temperature rise caused by a concentrated heat source. This spreading resistance could typically be 5 to 30% of the total heat sink resistance.

Metal heat sinks may act as electromagnetic radiators, even when earthed. When EMC is an issue, thermal conducting plastic resins (thermoplastics) may be a viable alternative to a metal heat sink. Thermal conductivities from 5 up to  $50\text{W/mK}$  (similar to stainless steel  $15\text{W/mK}$  and ceramic aluminium oxide  $25\text{W/mK}$ ) are a result of additives. Such composite plastic heat sinks (moulded base, folded fin) are 50% lighter than aluminium equivalents and advantageously are available in electrically insulative and electrical conductive grades.

### 6.3 Heatsink cooling enhancements

Other than natural convection cooling of heatsinks, other possible active thermal management technologies for power electronics applications include:

- Heatsink air-cooling with fans and blowers
- Enhanced air-cooling
  - Piezo fans
  - 'Synthetic' jet cooling
  - 'Nanolithing'
- Indirect liquid cooling
  - Heat pipes
  - Cold plates
- Direct liquid cooling
  - Immersion cooling
  - Liquid jet impingement
  - Spray cooling
- Microchannels and minichannels
- Electrohydrodynamic and electrowetting cooling
- Liquid metal cooling
- Solid-State cooling
  - Thermoelectric (Peltier devices)
  - Superlattice and heterostructure cooling
  - Thermionic and thermotunnelling cooling
- Phase change materials and heat accumulators

### 6.4 Heatsink fan and blower air-cooling

Fans are low-pressure air pumps that utilize power from an electric motor to output a volumetric flow of air at a given pressure. A propeller converts torque from the motor to increase static pressure across the fan rotor and to increase the kinetic energy of the air molecules. Electronic cooling fans draw or flow air from outside an electronic enclosure into the electronics area, expel heated air from inside the enclosure, or move air across a heat sink or electronic device to accelerate the removal of heat energy from the device.

Fan motors are typically permanent split capacitor ac induction or brushless dc.

Air moving devices are generally either a type of axial (and/or propeller) fan, figure 6.8a, or a centrifugal blower, figure 6.8b. The main difference between fans and blowers is their flow and pressure characteristics. The specific ratio - the ratio of the discharge pressure over the suction pressure - is used for defining fans ( $<1.11$ ), blowers ( $1.11$  to  $1.20$ ), and compressors ( $>1.20$ ). *Axial fans* take and deliver air in an overall direction that is parallel to the fan blade axis (no change in direction) and can be designed to deliver a high flow rate, but work against low pressure. *Radial (centrifugal) blowers* tend to deliver air in a direction that is perpendicular to the blower axis at a relatively low flow rate, but against high pressure. The air changes direction twice (on entering and on leaving).

The most common *axial fans* are propeller, tube-axial and vane-axial styles.

- Propeller fans are the simplest type of fan, consisting of a motor and propeller. One problem with propeller fans is that tip vortices are produced by the pressure differential across the airfoil section. The required pressure is low.
- A tube-axial fan (the most common type in electronic cooling systems) is similar to a propeller fan, but also has a Venturi around the propeller to reduce the vortices. It develops high pressure but has a low efficiency, with peak efficiency generally occurring just before the stall dip.
- The vane-axial fan has vanes that trail behind the propeller in the airflow to straighten the swirling flow created as the air is accelerated.

Impeller types, known as flat packs, have a small aspect ratio, with good flow rate and pressure drop.

*Centrifugal blowers* may have a forward curved wheel, a backward curved wheel, airfoil-tubular, or be of the squirrel cage (radial) variety. They tend to be quiet: noise decreases with increased number of blades and have excellent pressure drop characteristics.

*Mixed flow fans* combine the characteristics of both the axial fan the radial blower. The air flows in both axial and radial directions relative to the shaft. Mixed flow fans develop higher pressures than axial fans. In a *cross flow fan* the airflows in an inward direction and then in an outward radial direction.



type	Impeller design	Housing design	Performance characteristics
<b>Axial fans</b>			
<b>PROPELLER</b>			
<b>TUBE-AXIAL</b>			
<b>VANE-AXIAL</b>			

Table 6.5 Design, characteristics, and applications of axial fans and blowers

type	Impeller design	Housing design	Performance characteristics	applications
<b>AXIAL FANS</b>				
<b>PROPELLER</b>	<ul style="list-style-type: none"> <li>• Low efficiency</li> <li>• Limited to low pressure applications</li> <li>• Low cost impellers have at least two blades of constant thickness connected to a small hub</li> <li>• Primary energy transfer is by velocity pressure</li> </ul>	<ul style="list-style-type: none"> <li>• Simple circular ring, orifice plate or Venturi</li> <li>• Optimum design is small blade tip gap and forms smooth airflow into wheel</li> </ul>	<ul style="list-style-type: none"> <li>• High flow rate, but low efficiency and pressure capabilities</li> <li>• Maximum efficiency near free delivery (zero static pressure)</li> <li>• Discharge pattern circular and airstream swirls</li> </ul>	<ul style="list-style-type: none"> <li>• Low pressure, high volume air moving applications such as air circulation in a space or ventilation through a wall without ductwork</li> <li>• Some exhaust applications</li> <li>• Used for makeup air applications</li> </ul>
<b>TUBE-AXIAL</b>	<ul style="list-style-type: none"> <li>• More efficient and develops higher static pressure than propeller fans</li> <li>• Usually 4 to 8 blades with airfoil or single thickness cross section</li> <li>• Hub less than transfer by velocity pressure</li> </ul>	<ul style="list-style-type: none"> <li>• Cylindrical tube with close clearance to blade tips</li> </ul>	<ul style="list-style-type: none"> <li>• High flow rate, medium pressure capabilities</li> <li>• Higher efficiency than propeller types</li> <li>• Performance curve dips before peak pressure</li> <li>• Discharge pattern circular and airstream rotates or swirls</li> </ul>	<ul style="list-style-type: none"> <li>• Low and medium pressure ducted HVAC* applications where air disturbance downstream is not critical</li> <li>• Some industrial applications such as drying ovens, paint spray booths, and fume exhausts</li> <li>• HVAC Heating Ventilation and Air Conditioning</li> </ul>
<b>VANE-AXIAL</b>	<ul style="list-style-type: none"> <li>• Good blade design give medium to high pressure capability at good efficiency</li> <li>• Most efficient versions have airfoil blades</li> <li>• Blade may be fixed, adjustable or controllable pitch</li> <li>• Hub is usually less than half fan tip diameter</li> </ul>	<ul style="list-style-type: none"> <li>• Cylindrical tube with close clearance to blade tips</li> <li>• Guide vanes up or down stream from impeller increase pressure capability and efficiency</li> </ul>	<ul style="list-style-type: none"> <li>• High pressure characteristics with medium volume flow capabilities</li> <li>• Performance curve dips before peak pressure due to aerodynamic stall. Avoid operation in this region</li> <li>• Guide vanes correct circular motion imparted by wheel and improve fan pressure characteristics and efficiency</li> </ul>	<ul style="list-style-type: none"> <li>• General HVAC* systems with low, medium, to high pressure applications where straight through flow and compact installation are required</li> <li>• Good down-stream air distribution</li> <li>• Replaces tube-axial fans in industrial applications</li> <li>• More compact than centrifugal fans for same duty</li> </ul>

type	Impeller design	Housing design	Performance characteristics
<b>AIRFOIL</b>			
<b>BACKWARD INCLINED BACKWARD CURVED</b>			
<b>RADIAL</b>			
<b>FORWARD CURVED</b>			

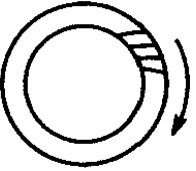
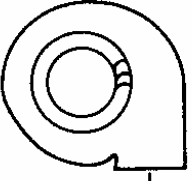
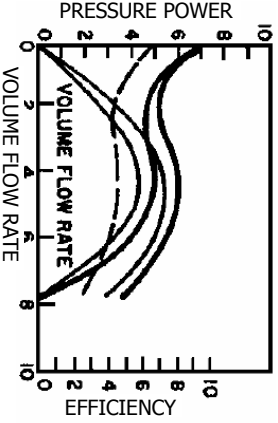
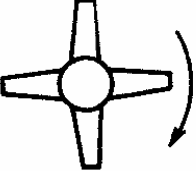
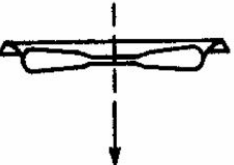
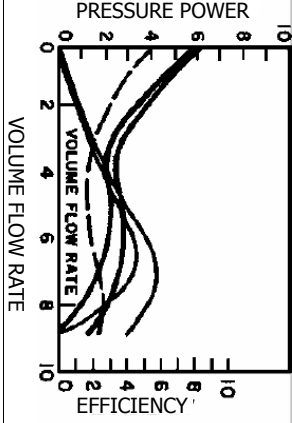
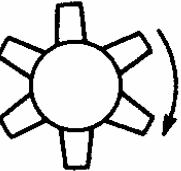
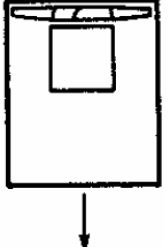
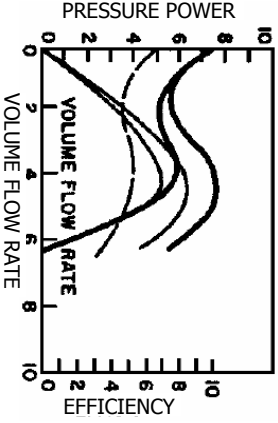
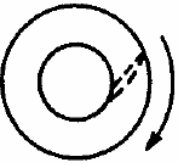
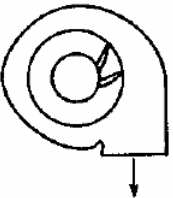
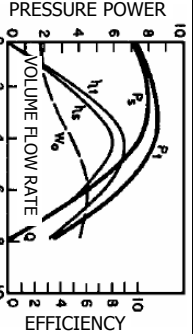
type	Impeller design	Housing design	Performance characteristics	applications
<b>AIRFOIL</b>	<ul style="list-style-type: none"> <li>• Highest efficiency of all centrifugal fan designs</li> <li>• 10 to 16 blades of airfoil contour curve backwards from rotation direction. Deep blade allow for efficient expansion within blade passage</li> <li>• Air leaves passage at velocity less than tip speed</li> <li>• For a given duty, has highest speed of centrifugal designs</li> </ul>	<ul style="list-style-type: none"> <li>• Scroll-type design for efficient conversion of velocity pressure to static pressure</li> <li>• Maximum efficiency requires close clearance and alignment between wheel and inlet</li> </ul>	<ul style="list-style-type: none"> <li>• Highest efficiencies at 50% to 60% of wide open volume. This volume has good pressure characteristics</li> <li>• Power reaches maximum near peak efficiency and decreases or self-limits toward free delivery</li> </ul>	<ul style="list-style-type: none"> <li>• General HVAC large systems</li> <li>• Large clean-air operations for significant energy savings</li> </ul>
<b>BACKWARD INCLINED BACKWARD CURVED</b>	<ul style="list-style-type: none"> <li>• Efficiency slightly less than airfoil fan</li> <li>• 10 to 16 single thickness blades curved or inclined away from rotation direction</li> <li>• Efficient for same reasons as airfoil</li> </ul>	<ul style="list-style-type: none"> <li>• Uses same housing configuration as airfoil design</li> </ul>	<ul style="list-style-type: none"> <li>• Similar to airfoil fan, except peak efficiency slightly lower</li> </ul>	<ul style="list-style-type: none"> <li>• HVAC, as for airfoil types</li> <li>• Industrial applications where airfoil blade may corrode or erode due to environment</li> </ul>
<b>RADIAL</b>	<ul style="list-style-type: none"> <li>• Higher pressure characteristics than airfoil and backward blade types</li> <li>• Curve has a break before pea pressure and fan should not be operated in this area</li> <li>• Power rises continually to free air delivery</li> </ul>	<ul style="list-style-type: none"> <li>• Scroll. Usually narrowest of all centrifugal designs</li> <li>• Because wheel design is less efficient, housing dimensions are not as critical as for airfoil and backward blade types</li> </ul>	<ul style="list-style-type: none"> <li>• Higher pressure characteristics than airfoil and backward blade fans</li> <li>• Pressure drop before peak pressure but this usually causes no problems</li> </ul>	<ul style="list-style-type: none"> <li>• Material handling in industrial plants</li> <li>• Rugged wheel is easy to repair. Wheel may be specially coated</li> <li>• Usual not for HVAC</li> </ul>
<b>FORWARD CURVED</b>	<ul style="list-style-type: none"> <li>• Flatter pressure curve and lower efficiency than airfoil and backward blade types</li> <li>• Do not rate fan in pressure dip before peak pressure</li> <li>• Power rises continually to free air delivery. Motor selection must account for this</li> </ul>	<ul style="list-style-type: none"> <li>• Scroll similar to possibly identical to other centrifugal designs</li> <li>• Fit between wheel and inlet not as critical as for airfoil and backward blade types</li> </ul>	<ul style="list-style-type: none"> <li>• Pressure curve less steep than backward curved fans. Curve dips before reaching peak pressure</li> <li>• Highest efficiency after peak pressure at 40 to 50% of wide open volume</li> <li>• Rate fan to volume greater peak pressure</li> <li>• Account for power curve which rises continually towards free delivery.</li> </ul>	<ul style="list-style-type: none"> <li>• Primarily for low-pressure HVAC, such as residential furnaces, central station units and packaged air-conditioners</li> </ul>

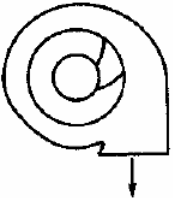
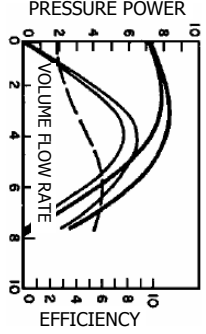
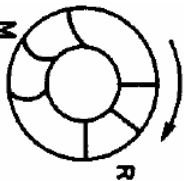
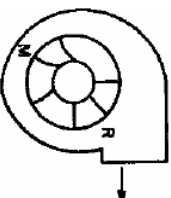
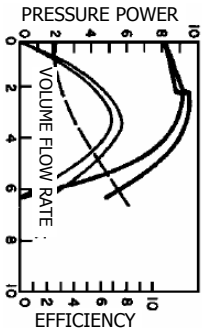
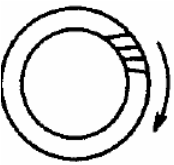
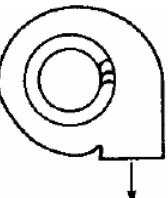
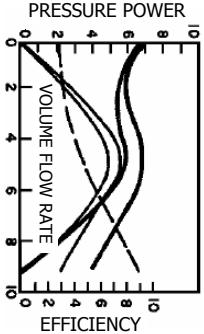
**CENTRIFUGAL FANS**



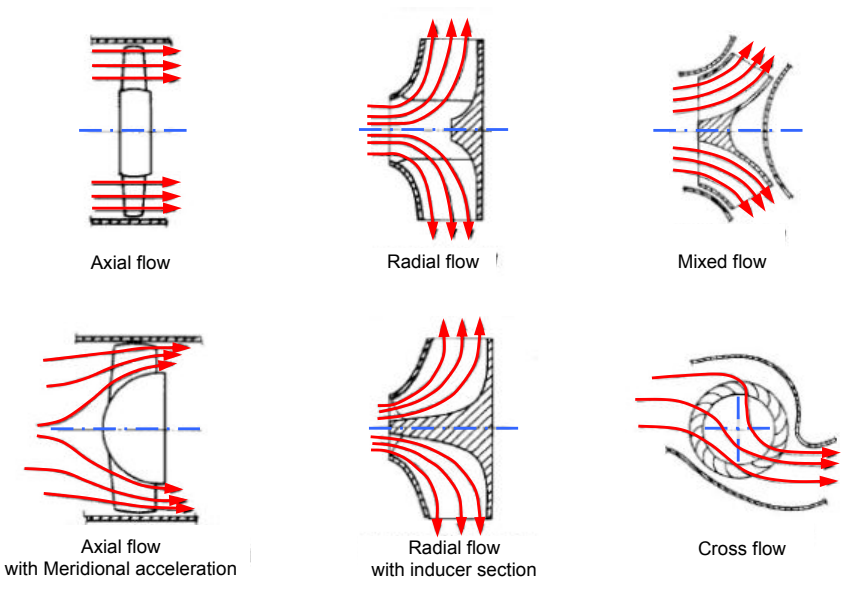

Pressure increase and flow rate in conjunction with the rotational velocity  $\omega$  at the perimeter, the outer diameter  $D_o$  of the impeller, and the density  $\rho_r$  of the fluid medium result in the dimensionless parameters *pressure figure*  $\Phi_r$  and *volume figure*,  $\theta_r$ .

$$\phi_r = \frac{\Delta p}{\sqrt{2\rho_r}\omega^2} \tag{6.3}$$

$$\theta_r = \frac{V}{\sqrt{A}\pi D_o^2\omega} \tag{6.4}$$

These parameters allow comparison of different designs, dimensions and speed, with one another. Figure 6.9 illustrates this comparison for typical characteristic curves of the various designs, making the advantages apparent, in particular:

- Radial fans give a large increase in pressure and low flow rates
- Mixed-flow fans give medium pressure and medium flow rates
- Axial fans give high volume flow rates and low increase in pressure

**The fan curve**

The aerodynamic aspects of a fan are exhibited in a fan curve such as is shown in figure 6.10. Healthy aerodynamic flow is on the x-axis and rotates anticlockwise through to aerodynamic stall (the vertical axis). A stalled fan continues to deliver air, but at an increased static pressure and a decreased volumetric flow rate, and also at the cost of an increase in noise. If noise is not a consideration, the fan can be utilized in this condition.

The fan performance curve can be understood in terms of energy. At the shut-off or no-flow point, A, the fan is in a condition of maximum potential energy, hence produces a maximum possible pressure. At free delivery, point D, the fan is in the maximum kinetic energy condition. Although neither of these extreme conditions are likely to occur in practice, they are useful parameters when comparing fans. The fan stall region, B, is unstable, and should be avoided. The region C to D is the fan stable low-pressure area, where a preferred operating point near D improves efficiency and compensates for filter clogging.

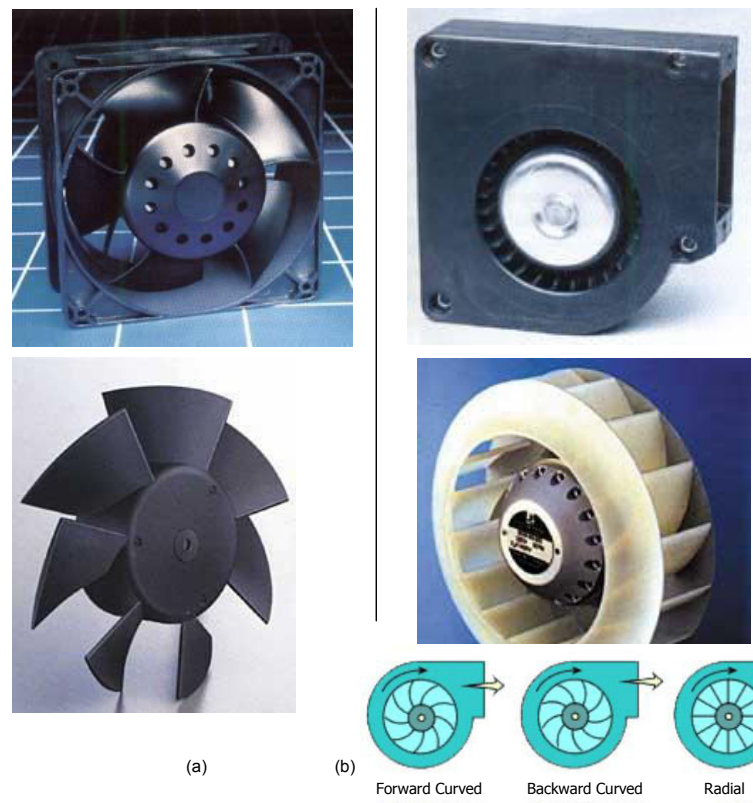

Figure 6.8. Typical (a) impeller axial fan and (b) radial blower with backward curved blades.

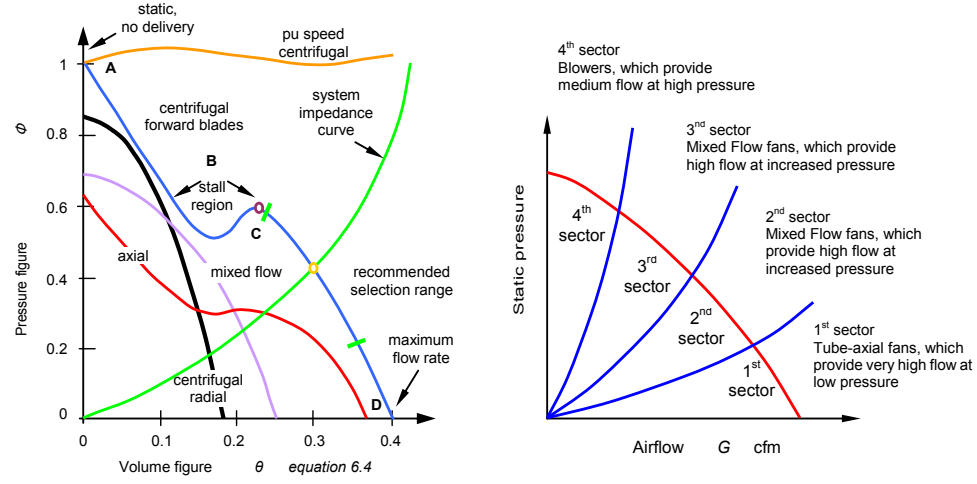

Figure 6.9. Fan curves: (a) comparison of normalized curves for various fan designs and (b) typical fan characteristic regions.

The governing principle in fan selection is that any given fan can only deliver one flow at one pressure in a particular system. This 'operating point' is determined by the intersection of the fan static pressure curve and the system pressure curve. Figure 6.10 illustrates the operating points of both high and low resistance systems. It is better to select a fan that gives an operating point toward the high flow, low-pressure end of the performance curve to maintain propeller efficiency and to avoid propeller stall. Each particular power electronic system should be analyzed for possible reduction in the overall resistance to airflow. Considerations, such as available space and power, noise, reliability, and operating environment are other deciding factors.



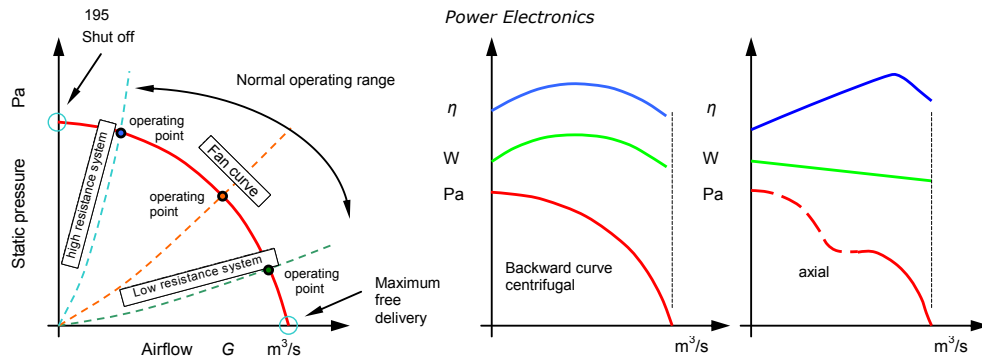

Figure 6.10. Fan curve: (a) fan (backward curved centrifugal) system interaction; input power and efficiency (b) backward curved centrifugal and (c) axial fans.

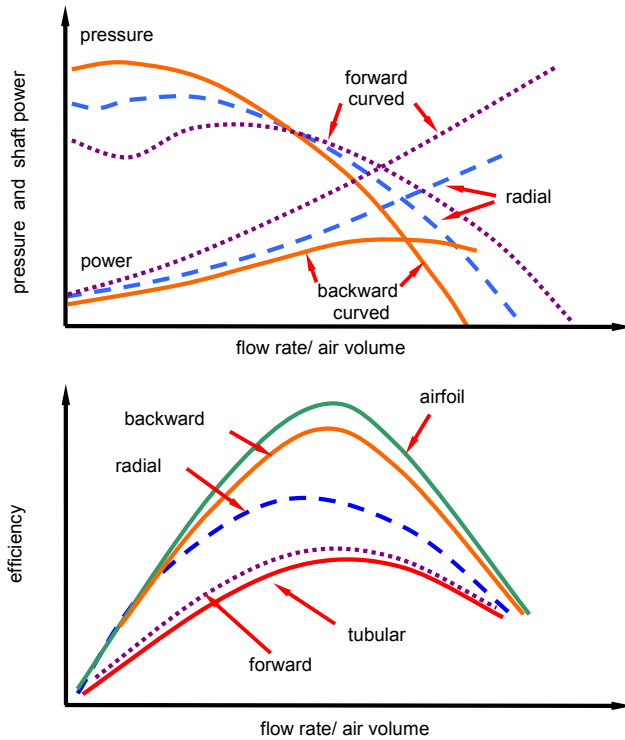

Figure 6.11. Fan curves: (a) shaft power and pressure and (b) efficiency fans versus flow rate.

**Acoustic noise**

Sound is propagated in air by pressure waves. The effective value of pressure change is expressed relatively as sound pressure level, SPL, in decibels, dB. The so-called A weighting curve is normally used and the sound pressure level obtained is expressed in dB(A).

$$SPL = 20 \log \frac{P}{P_{ref}} \tag{6.5}$$

where  $P$  is pressure and  $P_{ref}$  is the reference pressure

Since sound pressure level varies with distance to and direction of a device, it is not suitable as a fan comparison basis. By contrast, the sound power level,  $PWL$ , determined from sound pressure measurements, comprises all sound emissions, and is unaffected by distance to the fan noise source.

$$PWL = 10 \log \frac{W}{W_{ref}} \tag{6.6}$$

where  $W$  is the acoustic power of the source and  $W_{ref}$  is the acoustic reference power

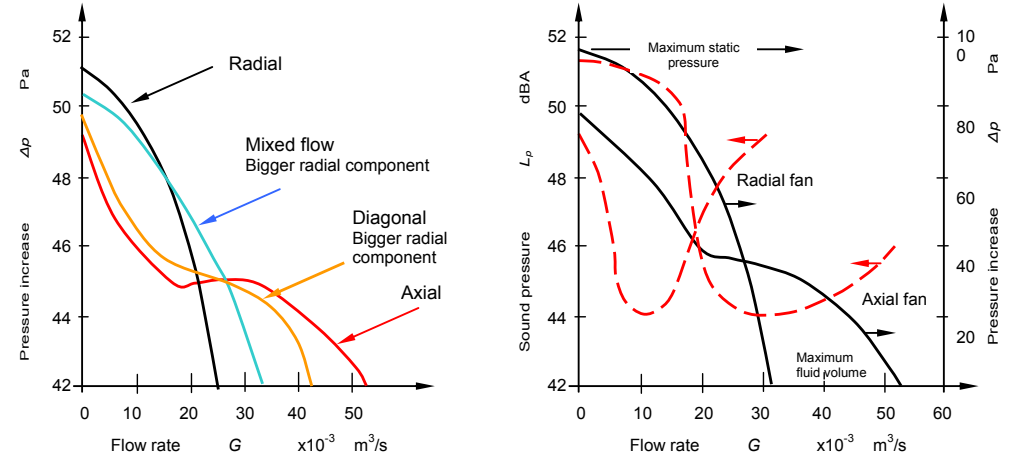

Figure 6.12. Sound pressure level characteristics at 1m; comparison between axial and radial fans.

The sound radiation of a fan changes with its operating state, so sound power level is only conditionally indicative for applications in which the fan does not operate under optimum conditions. A 'characteristic acoustical curve' of the fan results when the sound pressure level is measured in relation to a pressure increase or flow rate. Figure 6.12 depicts this characteristic for axial and radial fans, wherein the sound pressure level measured at a 1m distance from the fan intake side is depicted as a function of flow rate. For axial designs, a sharp increase in noise is particularly noticeable when the flow rate is excessively restricted. The axial fan enters an operating range in which the airflow no longer follows the contour of the impeller hub, resulting in additional noise.

For a specific operating point, an ideal blade geometry achieves the highest aerodynamic efficiency, which coincides with minimal noise generation. For this reason, the lowest noise generation can only be achieved for the given point of operation.

Sources of fan noise include:

- **Vortex shedding** - This is a broad-band noise source generated by air separation from the blade surface and trailing edge. It can be controlled by the blade profile design, proper pitch angle, and notched or serrated trailing blade edges.
- **Turbulence** - Turbulence is created in the airflow stream itself. It contributes to broad-band noise. Inlet and outlet disturbances, sharp edges and bends will cause increased turbulence and noise.
- **Speed** - Speed is a major contributor to fan noise and its effect can be seen through the fan laws in Table 6.6.
- **Fan load** - Noise varies as the system load varies. This variation is unpredictable and fan dependent. However, fans are generally quieter when operated near their peak efficiency.
- **Structure vibration** - This can be caused by the components and mechanism within the fan, such as residual unbalance, bearings, rotor to stator eccentricity and motor mounting. Motor mounting noise is difficult to define. Cooling fans are motors and should be treated as such when mounted.

The following points will aid in the minimization of fan noise.

- **System impedance** - This should be reduced so that the least noise for the greatest airflow is obtained. The inlet and outlet ports of a cabinet can make up to between 60 and 80% of the total system impedance, which is too high for a low-noise result. Also, if a large part of the

fan's flow potential is used up by the impedance of the inlet and outlet, a larger, faster and noisier fan will be required to provide the necessary cooling.

- **Flow disturbance** - Obstructions to the airflow must be avoided, especially in the critical inlet and outlet areas. When turbulent air enters the fan, noise is generated, usually in discrete tone form, adding up to 10 dB. Obstructions placed near the fan intake raise the noise level more than obstruction on the exhaust side of the fan.
- **Fan speed and size** - Most fans have several low speed versions. These should be assessed and used if possible. Various fan sizes should also be explored; quite often a larger, slower fan will be quieter than a smaller, faster fan delivering the same airflow.
- **Temperature rise** - Airflow is inversely proportional to allowable temperature rise within the system. Therefore, the  $\Delta T$  limit placed on the equipment will dictate the required flow, and therefore, noise. If the temperature limit can be relaxed slightly, a noise reduction results.
- **Vibration isolation** - Fan isolation from the cabinet will avoid vibration transmission. Because fans operate at a low frequency, and are light in weight, vibration isolators must be soft and flexible. Since noise transmission is system dependent, experimentation is the best approach to identify quiet system/fan interaction. In systems that require 20 cfm or less, noise radiated by the cabinet is the predominant noise, and isolation of the fan is the only practical solution. Mount the fan on the enclosure interior surface rather than on an exterior surface. Use structural reinforcements to control enclosure resonant frequencies.

#### 6.4.1 Fan selection

##### Estimate the required airflow

Before selecting a fan, it is necessary to estimate accurately the heat to be dissipated, because the overall system air temperature differential above the inlet ambient is directly proportional to the heat dissipated. Then the amount of required cooling air can be estimated.

The basic heat transfer equation is:

$$P_D = m_f \times c_p \times \Delta T \quad (6.7)$$

where  $P_D$  = amount of heat dissipated in the enclosure and transferred to the cooling system, W  
 $c_p$  = specific heat of air, 1.021 kJ/kg.K  
 $m_f$  = mass flow rate of air through enclosure, kg/s  
 $\Delta T$  = desired air temperature differential (enclosure inlet to discharge ambient outside air), K

The relationship between mass flow rate and volumetric flow rate is

$$m_f = \rho_f \times G \quad (6.8)$$

where  $G$  = volumetric flow rate,  $m^3/s$  [1 cfm = 1.7m<sup>3</sup>/h]  
 $\rho_f$  = air density,  $kg/m^3$ , which is altitude dependant, see Table 6.8

From equations (6.7) and (6.8), the required volumetric flow rate is calculated as

$$G = \frac{P_D}{\rho_f \times c_p \times \Delta T} = \frac{P_D}{c_v \times \Delta T} \quad \left[ = 0.78 \times 10^{-3} \frac{P_D}{\Delta T} \text{ at STP} \right] \quad (6.9)$$

This equation yields an estimate of the airflow needed to dissipate a given amount of heat at sea level. Note that it is the mass flow rate of air, not its volumetric flow rate that governs the amount of cooling.

##### Estimate the actual system airflow

The actual operating airflow is determined by the intersection of the fan curve and the system resistance curve, as shown in figure 6.9b. There are three options for estimating the operating point:

- experimental measurement using a thermal/mechanical mock-up of the system,
- calculation of the operating point using airflow network methods, or
- calculation of the system airflow using computational fluid dynamics software.

The experimental procedure can be used to measure the total airflow for specific fans or several pressure-airflow data pairs can be measured to develop a complete system resistance curve. The latter experimental method requires superimposition of the selected fan pressure versus airflow curve and system resistance curve to obtain the operating airflow.

The airflow network procedure provides adequate results when the geometry is simple and the flow path within the enclosure is known or an estimate can be made.

##### Determining system impedance

To estimate the system airflow, all enclosures are characterized by a system resistance curve of the type shown in Figure 6.13. System resistance curves are expressed as a non-linear expression of pressure versus airflow:

$$\Delta P = k_{exp} \times \rho_f \times G^{n_q} \quad (6.10)$$

where  $\Delta P$  = system static pressure loss [1Pascal = 1N/m<sup>2</sup> and velocity pressure  $P_v = \frac{1}{2}\rho_f v^2$ ]  
 $k_{exp}$  = a load or resistance factor specific to the system (determined experimentally)  
 $\rho_f$  = density of fluid, air  
 $G$  = airflow rate  
 $n_q$  = airflow quality constant, which varies between 1 and 2 depending on whether the flow is completely laminar ( $n_q = 1$ ) or completely turbulent ( $n_q = 2$ )

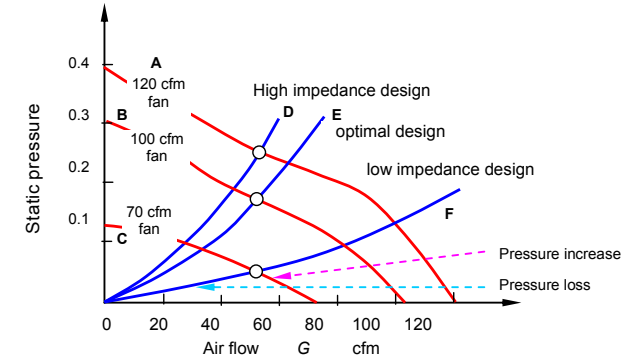

Figure 6.13. Fan characteristics of three different fans.

##### System flow

Once the volume of air and the static pressure of the system to be cooled are known, their intersection specifies the fan, specifically its airflow. To find the most effective fan for a system the typical airflow curve is divided into four sectors, as in Figure 6.9b. In general, each type of air mover will be best suited to one area, from high-flow/low-pressure to high-pressure/low-flow, as shown. Any given fan can only deliver one flow at one pressure in a given system.

Figure 6.9a shows a typical fan pressure versus flow curve along with what is considered the normal operating range of the fan. The fan, in any given system, can only deliver as much air as the system will pass for a given pressure. If the estimated value of the actual airflow is significantly less than the required value, before increasing the number of fans in a systems, or attempting to increase the air volume using a larger fan, the system should be analysed for possible reduction in the overall resistance to airflow. Other considerations, such as available space and power, noise, reliability, and operating environment should also be considered.

If this should fail to provide a solution, a different fan or perhaps even multiple fans should be considered. The consideration of multiple fans is more complex. An additional fan doubles the cost, doubles the noise, doubles the heat generated by fans, and may provide only a minimal improvement to the cooling, but redundant fans may increase system reliability.

##### Impact of varying system impedance

To demonstrate the impact of system resistance on fan performance, figure 6.13 shows three typical fans, where A is a 120cfm fan, B is a 100cfm fan and C is a 70cfm fan. Line D represents a system impedance within a given designed system. If 50cfm of air are needed, fan A will meet the need. However, fan A is a high performance, high noise fan that draws more power and is more costly. If the system impedance could be improved to curve E, then fan B would meet the 50cfm requirement, with reduced cost, noise and power draw. If the system impedance could be optimized to where curve F were representative, then fan C meets the airflow requirement, at a dramatically lower power, noise and cost level. This is a well-designed system from a forced convection cooling viewpoint, noting that a given fan can only deliver a single airflow into a given system impedance.

##### Multiple fans - series and parallel operation

Combining fans in series or parallel can achieve the desired airflow without greatly increasing the system enclosure size or fan diameter.

- Parallel operation is two or more fans blowing together side by side. The performance of two fans in parallel will increase the volume flow rate (by  $\Delta G$  and double at maximum delivery). The best results for parallel fans are achieved in systems with low resistance. A fan curve simulating multiple, identical fans in parallel may be constructed by scaling the fan curve airflow axis data in direct proportion to the number of fans. As figure 6.14 shows, when a system curve is overlaid on the parallel performance curves, the higher the system resistance, the lower the flow gain with parallel fan operation. Thus, this type of application should only be used when the fans can operate in a low impedance near free delivery.

- In series operation, the fans are stacked one upon the other, resulting in an increase of static pressure,  $\Delta P$ , doubling at shut-off, but less elsewhere, as seen in figure 6.14. The best results for series fans are achieved in systems with high resistance. A fan curve simulating multiple, identical fans in series, may be constructed by scaling the fan curve pressure axis data in direct proportion to the number of fans.

In both series and parallel fan operation, certain areas of the combined performance curve will be unstable and should be avoided. This instability is unpredictable and is a function of the fan and motor construction and the operating point.

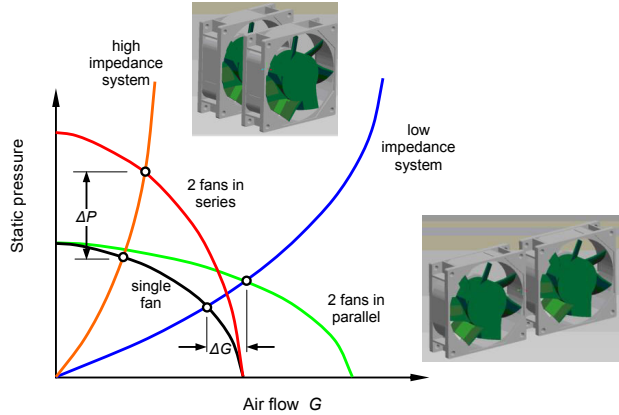

Figure 6.14. The effects of multiple fans (series versus parallel fan operation) on system pressure and flow rate.

6.4.2 The fan (affinity) laws

It may be necessary to determine the output of a given fan under other operating conditions of speed or fluid density, or to convert the known performance of an air mover of one size to that of another geometrically similar unit of a different size. The fan laws permit this and geometrically similar fans can be characterized by the following five equations:

Volumetric Flow-rate:  $G = K_g ND^3$   
 Mass Flow Rate:  $m_f = K_m \rho_f ND^3$   
 Pressure:  $P = K_p \rho_f N^2 D^2$  (6.11)  
 Power:  $HP = K_{HP} \rho_f N^3 D^5$   
 sound:  $L_w = 3.71 \log_{10} V_t + 0.96 \log_{10} Q - 10.8$  (imperial units)

where:  $K_g, K_m, K_p, K_{HP}$  = constants for geometrically and dynamically similar operation  
 $G$  = volumetric flow rate,  $m^3/s$   
 $m_f$  = mass flow rate,  $kg/s$   
 $N$  = fan impeller speed,  $rps$   
 $D$  = fan diameter,  $m$   
 $HP$  = impeller input power to rotate  
 $\rho_f$  = air density,  $kg/m^3$   
 $L_w$  = sound pressure level,  $dB$   
 $V_t$  = tip speed of impeller

These five fan laws apply where the fan airflow rate and pressure are independent of Reynolds's number,  $Re$ , specifically when

$$Re = \frac{\pi \rho_f ND^2}{C_R \nu} > 2 \times 10^6 \quad (6.12)$$

where  $C_R$  = correction factor  
 $\nu$  = absolute viscosity,  $Ns/m^2$

From these relationships, it is possible to calculate fan performance at a different condition. Table 6.6 is a summary of the fan law equations in a dimensionless form, useful for fan analysis.

Table 6.6: Basic fan laws, scaling

Variable	Constants	Fan Laws
Speed ( $N$ )	Diameter ( $D$ ) Density ( $\rho_f$ )	$G_2 = G_1 (N_2 / N_1)$ $P_2 = P_1 (N_2 / N_1)^2$ $HP_2 = HP_1 (N_2 / N_1)^3$
Diameter ( $D$ )	Speed ( $N$ ) Density ( $\rho_f$ )	$G_2 = G_1 (D_2 / D_1)^3$ $P_2 = P_1 (D_2 / D_1)^2$ $HP_2 = HP_1 (D_2 / D_1)^5$
Density ( $\rho_f$ )	Diameter ( $D$ ) Speed ( $N$ ) Volumetric Flow Rate ( $G$ )	$P_2 = P_1 (\rho_2 / \rho_1)^2$ $HP_2 = HP_1 (\rho_2 / \rho_1)^5$
Density ( $\rho_f$ )	Diameter ( $D$ ) Mass Flow Rate ( $m$ )	$G_2 = G_1 (\rho_2 / \rho_1)$ $P_2 = P_1 (\rho_2 / \rho_1)$ $N_2 = N_1 (\rho_2 / \rho_1)$ $HP_2 = HP_1 (N_2 / N_1)^2$

$$\text{sound: } L_{w2} = L_{w1} + 55 \log_{10} \left( \frac{N_2}{N_1} \right) + 55 \log_{10} \left( \frac{D_2}{D_1} \right) + 20 \log_{10} \left( \frac{\rho_2}{\rho_1} \right)$$

Example 6.1: Fan laws

A chassis uses a single 120mm fan for cooling. The maximum acceptable temperature rise in the enclosure is 15°C, when it dissipates 900W. A redesign results in the power dissipation increasing to 1200W. At 900W dissipation, the 120mm fan produces a 3m<sup>3</sup>/s flow rate at 3000rpm using 8W of power. What are the fan requirements at 1200W enclosure dissipation?

Solution

The new flow rate, from equation (6.9), is

$$G = \frac{P}{\rho \times C_p \times \Delta T} = \frac{0.05 \times P}{\Delta T} = \frac{0.05 \times 1200W}{15K} = 4m^3/s$$

This is a flow increase of 1m<sup>3</sup>/s.

The volumetric flow rate  $G$  is given by equation (6.11)

$$G = K_g ND^3$$

that is

$$\begin{aligned} rpm_2 &= \frac{G_2}{G_1} \times rpm_1 \\ &= \frac{4m^3/s}{3m^3/s} \times 3,000rpm = 4,000rpm \end{aligned}$$

The fan power requirements are given by

$$HP = K_{HP} \rho N^3 D^5$$

that is

$$\begin{aligned} Power_2 &= Power_1 \times \left( \frac{rpm_2}{rpm_1} \right)^3 \\ &= 8W \times \left( \frac{4,000}{3,000} \right)^3 = 19.0W \end{aligned}$$

The pressure increase produced is given by

$$P = K_p \rho N^2 D^2$$

that is

$$\begin{aligned} \text{Pressure}_2 &= \text{Pressure}_1 \times \left( \frac{rpm_2}{rpm_1} \right)^2 \\ &= \text{Pressure}_1 \times \left( \frac{4,000}{3,000} \right)^2 = \text{Pressure}_1 \times 1.78 \end{aligned}$$

The pressure is increased by 77.8%. The expected noise increase is  $55 \times \log_{10}(4000/3000) = 6.87\text{dB}$ .

### Fan Efficiency

The overall fan efficiency,  $\eta_f$ , is the ratio between power transferred to the airflow (power output from the impeller) and the electrical input power used by the fan. The fan efficiency is in general independent of air density and can be expressed as:

$$\eta_f = \frac{P_f}{P_e} = \frac{\Delta p \times G}{P_e}$$

where

$P_e$  is the electrical power input to the fan motor (W)

$P_f$  is the fan power output calculated from volume flow ( $\text{m}^3/\text{s}$ ) and pressure developed (Pa).

$G$  = air volume delivered by the fan ( $\text{m}^3/\text{s}$ )

$dp$  = static/total pressure (Pa)

The pressure could be total (mechanical) or static pressure and there can be a significant difference.

The equation for determining mechanical efficiency is:

$$\eta_{f-\text{mechanical}} = \frac{\Delta p(\text{total pressure}) \times G}{P_e} \quad (6.13)$$

The static efficiency equation is the same except that the outlet velocity pressure is not added to the fan static pressure

$$\eta_{f-\text{static}} = \frac{\Delta p(\text{static pressure}) \times G}{P_e} \quad (6.14)$$

**Table 6.7 Fan peak efficiencies**

	Fan type	Peak efficiency range, %
Centrifugal fan	Airfoil backward curved/inclined	79-83
	Modified radial	72-79
	Radial	69-75
	Pressure blower	58-68
	Forward curved	60-65
axial fan	Vane axial	78-85
	Tube axial	67-72
	Propeller	45-50

### Density (altitude) effects on fan performance

Since a radial fan is a constant volume machine, it will move the same volume flow of air  $G$  independent of the density of the air, as shown in figure 6.15. A fan is not a constant mass flow machine, therefore mass flow  $m$  changes as the density changes. This is important when equipment must operate at various altitudes. The mass flow  $m$  is directly proportional to density change  $\Delta\rho$ , while the volume flow  $G$  remains constant. As air density decreased, mass flow decreases and the effective cooling diminishes proportionately. Therefore, equivalent mass flow is needed for equivalent cooling, or the volume flow required at altitude (low-density air) will be greater than that required at sea level to obtain the equivalent heat dissipation.

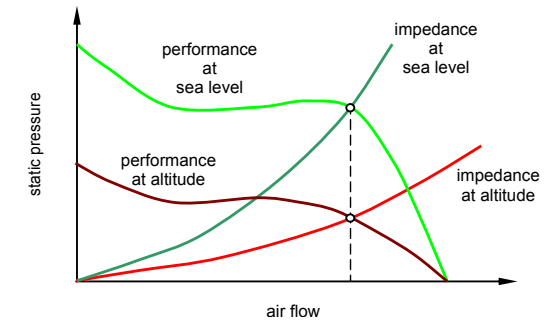

Figure 6.15. Density effects on fan performance.

$G$  is volumetric flow rate; a measurement of volume over time. It pertains to no particular gas or gas density.  $G$  is strictly a rate of volume measurement. But within that volume of gas, and in this case - air, the quality of the air and its ability to transfer heat can be calculated. Every molecule of air has a mass, and this mass has the ability to absorb or emit energy; also known as transferring heat. The number of molecules for a given volume gives the density of the air (mass/volume). If more molecules of air are packed into a given volume, increasing the density, mass per volume increases and the ability to transfer heat increases; and vice versa.

At sea level, the density of air is  $1.19\text{kg}/\text{m}^3$ , as seen Table 6.8. This value is created by all of the other molecules in the atmosphere weighing down on the molecules at sea level. As the elevation increases, there are fewer higher up molecules weighing down and the density of the air decreases. At non-sea level altitudes, the heat transfer equation is recalculated using the appropriate density for the altitude that the fan is operating at. In equation (6.9), the specific heat,  $c_p$ , which is mass dependant, is a constant for a given molecule, viz.  $1.021\text{kJ}/\text{kg}\cdot\text{K}$  for air.

**Table 6.8: Air density  $\rho_f$  and thermal resistance change with altitude,  $z$**

Altitude $z$	Density $\rho_f$	Heatsink thermal resistance multiplier, p.u.		
		Fan-Cooled (General)	Fan-Cooled (High Power)	Naturally Cooled $\frac{R_p(z)}{R_{p, \text{sea level}}} = \frac{1}{1 - 5 \times 10^{-5} z}$
m	$\text{kg}/\text{m}^3$			
Sea Level	1.19	1.00	1.00	1.00
1,500	1.06	1.20	1.16	1.10
3,000	0.904	1.45	1.35	1.21
4,500	0.771	1.77	1.58	1.33
6,000	0.652	2.18	1.86	1.48
7,600	0.549			
9,100	0.458			

### Enclosure cooling

In addition to selecting a fan, it is important to consider fan placement in or on the enclosure. Pressurizing (as opposed the evacuating) the enclosure is the preferred cooling method, since incoming air can be readily filtered. In addition, a pressurized enclosure will prevent dust entering through cracks or crevices. The fan is also transferring cooler, denser air, and therefore has a slightly higher-pressure capability, which may be a slight advantage for low heat dissipating systems. An important feature of a pressurized system is that the fan life and reliability are increased due to the fan ambient temperature being lower. The disadvantage of pressurization is that heat generated by the fan is dissipated into the enclosure.

When locating the fan or fans, the enclosure layouts illustration in Figure 6.16 highlight some desirable cooling aspects. The airflow path will always take the path of least resistance, so use baffles to eliminate recirculation of the same air and to direct the airflow. Importantly, air is forced in at a lower level than the outlet vents in order to benefit from the chimney effect, where less dense (hot) air rises.

- Locate components with highest heat dissipation near the enclosure air exits.
- Size the enclosure air inlet and exit vents at least as large as the Venturi opening of the fan used.
- Allow enough free area for air to pass with a velocity less than 7m/s.
- Avoid hot spots by spot cooling with a small fan.
- Locate components with the most critical temperature sensitivity nearest to inlet air to provide the coolest airflow.
- Blow air into cabinet to keep dust out, that is, pressurize the cabinet.
- Use the largest area filter possible, in order to:
  - increase dust capacity
  - reduce pressure drop.

#### 6.4.3 Estimating fan life

Convection air-cooling is the most commonly used method of cooling power electronics. In order to deliver air-cooled equipment with higher reliability, life expectancy of the air moving devices must be considered.

##### Definition of Fan Failure

Fan parametric failures typically include excessive vibration, noise (+ 3dBA), rubbing or hitting of the propeller, reduction in rotational speed ( $< 0.8 \times N_{nom}$ ), increased running current ( $> 1.2 \times I_{nom}$ ), etc. Non-functional failure include locked rotor and failure to start. Increased noise is a result of a bearing failure, which is usually caused by a loss of lubricant, which leads to bearing wear.

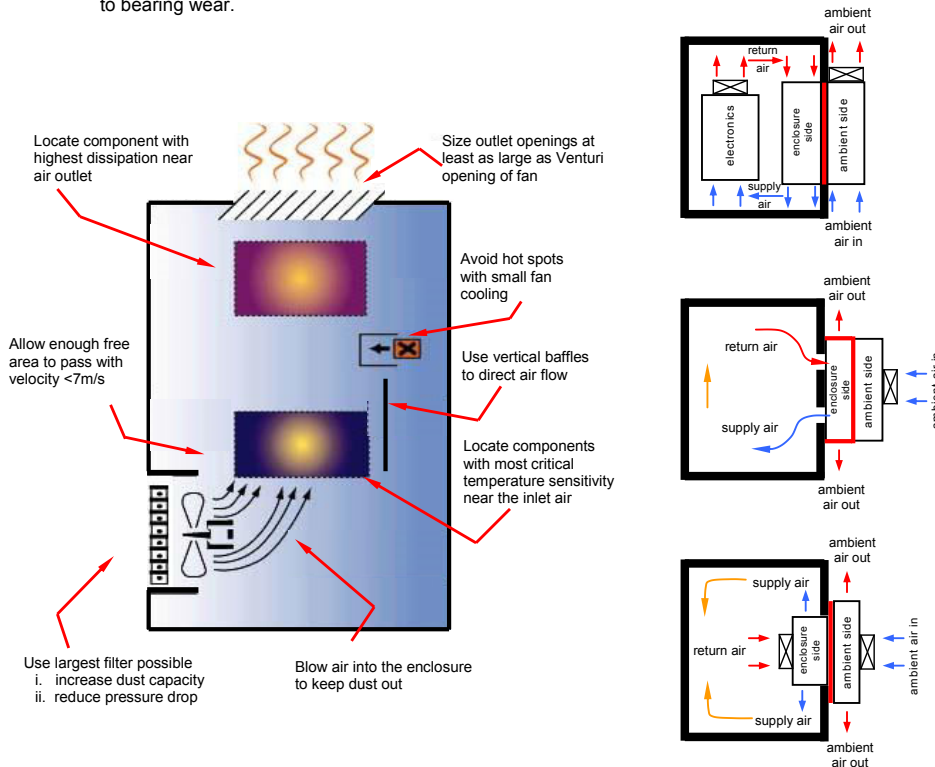

Figure 6.16. Cabinet cooling, external mount versus through-mount, with vertical orientation.

The capacitor may fail in ac fans and the electronics may contribute to early failures in dc fans. Failure criteria in fan life tests can also include a change in coast-down time or start time to reach full speed. Problems with winding insulation breakdown or similar, are classified as workmanship problems or an out-of-control manufacturing process.

##### Reliability concepts

Experimentation and model fitting have shown that the Weibull distribution provides a good fit to fan life data, because it accurately represents wear-out phenomena. For the Weibull distribution, the cumulative distribution function, a function of age  $t$ , is given by

$$F(t) = 1 - e^{-\left(\frac{t}{\alpha_s}\right)^{\beta_s}} \quad (6.15)$$

where  $\alpha_s$  is the characteristic life (for example, 9780 hours) and  $\beta_s$  is the shape parameter (for example, 4.9).

Shape parameters for Weibull models fit to fan life are generally greater than 1, which means that a fan's failure tendency increases with age (wear-out). The reliability function is  $1 - F(t)$ , which at any age  $t$  represents the proportion of survivors from the original population. The Weibull hazard rate (also known as the failure rate or hazard function) is given by

$$H(t) = \frac{\beta_s}{\alpha_s} \times \left(\frac{t}{\alpha_s}\right)^{\beta_s-1} \quad (6.16)$$

Two metrics of fan reliability are the  $L_2$  life and  $L_{10}$  life, which are the second and tenth percentiles under some assumed fan life distribution, such as the Weibull distribution.  $L_{10}$  refers to the time at which 90% of a large population of fans continue to operate. Since  $F(t) = 0.1$  at  $L_{10}$  and 0.02 at  $L_2$  in equation (6.15):

$$L_{10} = \alpha_s \times 0.10536^{1/\beta_s} \quad L_2 = \alpha_s \times 0.02020^{1/\beta_s} \quad (6.17)$$

For example, given  $\alpha_s = 100k$  POH (power on hours) and  $\beta_s = 1.5$ ,  $L_2 = 7,418$  hours represents the age at which 98% of the population is expected to still be operating. The advantage of specifying an  $L_2$  life in place of  $L_{10}$  life, is that the desired early life failure distribution is more tightly specified.

Sometimes the mean time to failure (mttf) is also quote. For the Weibull distribution

$$mttf = \alpha \times \Gamma\left(1 + \frac{1}{\beta}\right) \quad (6.18)$$

where  $\Gamma$  denotes the Gamma function.

The mttf is often confused with the mean time between failures (mtbf). The mtbf should only be used in a repairable system setting. If a system uses ten fans, and any failed fan is promptly replaced, then the mtbf may be used to understand the system's maintenance needs and service cost. But since the underlying hazard rate of the fans is not constant, computing the mtbf of a multiple-fan system is quite difficult. Instead, system reliability studies use a one-number hazard rate for the individual fans, in which case the average hazard rate may be appropriate.

##### Fan life estimation

The life of most fans is limited by the bearings. Electronics, even in dc fans, play a secondary role. When temperatures range from 25 to 60°C, ball bearing fans on average outlasted sleeve-bearing fans by 50%. When temperatures exceeded 70°C, ball bearing fans ran for 45,000 hours, while sleeve-bearing fans became inoperable. Yet, when the ambient temperatures are relatively low, sleeve bearing fans lasted as long as ball bearing fans. Therefore, if an application generates high levels of heat, a ball bearing fan is used. If the equipment generates low heat intensities, or if the equipment has a short life span, a sleeve-bearing fan can be used.

Bearing life is generally limited by the grease life, which is primarily a function of temperature. Grease life is affected by the type of grease, percentage of grease fill, operating environment, load, and bearing design. The Booser grease life equation is based on grease life tests on electric motor bearings, and is valid for rolling-element bearings. The equation for the bearing grease life in the application is

$$\log L_{10} = -2.6 + \frac{K_f}{T_{brg}} - 0.301 \times S_{1/2} \quad (6.19)$$

where

$$S_{1/2} = S_G + S_N + S_P \quad (6.20)$$

$$S_N = 0.86 \times \frac{D_H \times N}{DN_L}$$

where

$$S_P = 2.95 \times \frac{D_H \times N \times P}{C_r^2}$$



$P$	equivalent dynamic bearing load, kg
$N$	speed, rpm
$C_r$	basic dynamic load Capacity, kg
$D_H$	bore diameter, mm
$DN_L$	speed limit, rpm-mm
$S_{1/2}$	half-life subtraction factor; for $S_{1/2} = 1$ , the life falls 50%
$S_G$	grease half-life subtraction factor, typically 0 for many greases
$S_N$	speed half-life subtraction factor
$S_P$	load half-life subtraction factor
$k_T$	grease temperature factor = 2450 for acceleration factor of 1.5 for each 10°C
$T_{brg}$	bearing temperature, K

This equation, however, does not account for the effect of grease quantity and may not cover all available greases, particularly modern synthetic oils. For these new greases and depending upon the operating conditions, the results from the Booser equation may be conservative. Therefore, unless adjustment factors are available for a certain fan type, it is better to use the Booser equation to obtain a qualitative comparison of two fan designs rather than an absolute life estimate.

### Example 6.2: Fan lifetime

Calculate fan tenth percentile lifetime,  $L_{10}$ , using the following fan data sheet information.

$P = 960\text{g}$ ,
$C_r = 57\text{kg}$ ,
$D = 3\text{ mm}$
$N = 2200\text{ rpm}$ ,
$DN_L = 270,000\text{ rpm-mm}$ ,
$T_{brg} = 42^\circ\text{C}$ when $T_{amb} = 25^\circ\text{C}$

### Solution

The half-life subtraction factor, from equation (6.20), is calculated as

$$S_N = 0.86 \times \frac{D \times N}{DN_L} = 0.86 \times \frac{3\text{mm} \times 2200\text{rpm}}{270,000\text{rpm-mm}} = 0.021$$

$$S_P = 2.95 \times \frac{D \times N \times P}{C_r^2} = 0.28 \times \frac{3\text{mm} \times 2200\text{rpm} \times 0.96\text{kg}}{57\text{kg}^2} = 0.540$$

thus

$$S = S_G + S_N + S_P = 0 + 0.021 + 0.540 = 0.561$$

$$k_T = 2450 / 1.5^{(25-42)/10} = 2450 / 1.5^0 = 2450, \text{ that is, assume no temperature derating.}$$

From equation (6.19)

$$\begin{aligned} \log L_{10} &= -2.6 + \frac{2450}{273.2^\circ\text{C} + 42^\circ\text{C}} - 0.301 \times 0.561 \\ &= -2.6 + 7.78 - 0.169 = 5.01 \end{aligned}$$

The resulting life estimate is  $L_{10} = 102,000$  hours. ♣

In situations where fan reliability is critical, limit the bearing temperature rise to 10°C, particularly when a single fan failure results in a system shutdown. The Booser life estimate can also be significantly affected by the bearing load and the bearing size. Installing a fan with the shaft mounted vertically will result in a lower bearing load and a longer fan life. Using a larger bearing will also yield a longer fan life.

### Fan life experiments

Because of economic and time constraints, a zero failure test strategy and/or accelerated testing techniques are adopted. A zero failure test strategy may be used to estimate the test time required to verify a life expectancy criterion such as a minimum  $L_{10}$  life. The precision of this approach depends on the accuracy of the shape parameter assumption.

### Example 6.3: Fan testing

How long should a sample size of 30 fans be tested to determine with 90% confidence that  $L_{10}$  is greater than or equal to 80,000 hours, at 30°C?

### Solution

Assuming a Weibull distribution, each of  $n$  fans should be tested  $t_1$  hours, with

$$t_1 = \alpha \left[ \chi_{2n}^2 \frac{C}{2n} \right]^{\frac{1}{\beta}}$$

where  $\chi_{2n}^2$  is the  $C$ -th percentile of the Chi Square distribution with two degrees of freedom;  $C$  is determined by the desired confidence level. From a Chi Square table,  $\chi_{2, 0.90}^2 = 4.60$ .

Assuming  $\beta = 2$ , solving for  $\alpha$  in equation (6.17) gives

$$\alpha = L_{10} (0.10536)^{-1/2} = 246,460 \text{ hours}$$

Substituting  $\alpha$ , with  $n = 30$  into the Weibull distribution equation, gives  $t_1 = 68,280$  hours of test time for each fan. If all 30 fans operate  $t_1$  hours, at 30°C, without failure, then it can be asserted with 90% confidence that  $L_{10}$  is at least 80,000 hours. ♣

### Accelerated Life Testing

Since life test durations are lengthy, even when a zero failure test strategy is used, accelerated testing techniques are essential to complete component evaluation within a reasonable time and cost.

The first acceleration factor is on/off cycles. These cycles stress the fan by accelerating the bearing from zero speed to normal speed. An on/off cycle every 8 hours would be representative of a personal computer application. Even if this degree of stress is not appropriate, some on/off cycles are required to detect fan problems such as failure to start, changes in rotational speed, coast down time or start time, and increased noise.

Elevated temperature is generally the primary acceleration factor. The range of acceleration factors typically used in fan reliability calculations is 1.3 to 2 per 10°C increase. For fan failures caused by lubricant breakdown, it is reasonable to use the acceleration factor of 1.5 per 10°C increase as in Booser's equation. For example, to extrapolate the results of a life test run at 80°C down to 40°C, use a decreasing acceleration factor of  $1.5^{(80-40)/10} = 5.1$ .

At the accelerated life test temperature, there should not be a significant change in grease structure. The performance of the grease is degraded mainly due to evaporation loss and oxidation. Accelerated life testing should therefore be conducted at air temperatures below 85°C.

Although Booser's nominal temperature acceleration factor applies specifically at a bearing temperature of 100°C, no model exists for a room temperature of 25°C.

A reliable fan will maintain system cooling and protect against system meltdown. A quality axial fan can fulfil these requirements. Debate exists over which bearing (ball or sleeve) to use in the axial fan. The bearing type is a crucial factor in determining an axial fan's reliability. Table 6.9 outlines the relative features of the two bearing types when used in axial fans.

Table 6.9: Fan ball and sleeve bearing comparison

Criteria	Ball Bearing	Sleeve Bearing
Fan Longevity	Longer life	Shorter life
Heat Endurance	Higher	Lower
Fan Mounting Options	Vertical, shaft centre line parallel, perpendicular	Vertical
Noise Emission	Quieter at high speeds	Quieter at low speeds in early life
Parts	Precision	Non-precision
Lubricant	Less evaporation	More evaporation
Contact	Point	Line
Cost	More expensive per unit	Less expensive per unit

In summary, if the system has a short life span, or will not generate high levels of heat, a sleeve-bearing fan can be used. However, if the application is a densely packed or a compact electronic system, a ball bearing fan will endure hotter temperatures, have a greater life span, and ultimately provide a better long-term investment.



## 6.5 Enhanced air cooling

With ever increasing gravitational and volumetric power density demands, traditional air-cooling techniques have reached their limit for cooling of high-power applications. With standard fans and blowers, a maximum heat transfer coefficient of  $h = 150\text{W/m}^2\text{K}$  can be reached with acceptable noise levels, which is about  $1\text{W/cm}^2$  for a  $60^\circ\text{C}$  temperature difference. Using 'macrojet' impingement, theoretically  $900\text{W/m}^2\text{K}$  may be reached, but with unacceptable noise levels. Dedicated non-standard fans - heat sink combinations for cooling have a maximum of about  $50\text{W/cm}^2$ . Advanced methods to extend the useful range of air-cooling are *piezo fans*, *'synthetic' jet cooling*, and *'nanolightning'*.

### Piezo fans:

Piezoelectric fans are low power, small, relatively low noise, solid-state devices that are viable thermal management solutions for a variety of portable power electronics applications in laptop computers and cellular phones. Piezoelectric fans utilize piezoceramic patches bonded onto thin, low frequency flexible blades to drive the fan at its resonance frequency. The resonating low frequency blade creates a streaming airflow directed at the electronic components.

### 'Synthetic' jet cooling:

Due to the periodic pulsating flow nature, synthetic jets introduce a stronger entrainment than conventional-steady jets of the same Reynolds number and more vigorous mixing between the wall boundary layers and the rest of the flow. A synthetic jet draws cool air from ambient, impinges on the top hot surface and circulates the heated air back to the ambient through the edges of the plate. A radial counter air current flow is created in the gap between the plates with hot air dispersed along the top and ambient air entering along the bottom surface.

### 'Nanolightning':

'Nanolightning' increases the heat transfer coefficient with 'micro-scale ion-driven airflow' using high electric fields created by nanotubes. The ionized air molecules (tiny wind currents) are moved by another electric field, thereby inducing secondary airflow. Cooling at a heat flux level of  $40\text{W/cm}^2$  (similar to water) is possible.

## 6.6 Liquid coolants for power electronics cooling

Although air-cooling continues to be the most widely used method for cooling electronic packages, significantly higher heat fluxes ( $\text{W/m}^2$ ), due to the higher heat transfer coefficient are achievable with liquid cooling. Coolants are used in both single phase and two-phase applications.

- A *single-phase* cooling loop consists of a pump, a heat exchanger (cold plate/mini- or micro-channels), and a heat sink (radiator with a fan or a liquid-to-liquid heat exchanger with chilled water-cooling). The heat source in the power electronics system is attached to the heat exchanger. The fluid does not change state: water does not change to steam.
- Liquid coolants are also used in a *change of state* or *two-phase systems*, such as heat pipes, thermo-siphons, sub-cooled boiling, spray cooling, and direct immersion systems.

A heat flux of  $2\text{kW/cm}^2$  can be removed through boiling water, based on water molecules turning into vapour without influencing each other, using high velocities and high pressures. Available microcoolers can handle about  $1\text{kW/cm}^2$ . Liquid cooling for power electronics applications is generally divided into the two main categories of *indirect* and *direct* liquid cooling.

- *Indirect liquid cooling* is one in which the liquid does not directly contact the components to be cooled.
- *Direct liquid cooling* brings the liquid coolant into direct contact with the components to be cooled.

The following sections discuss indirect liquid cooling in the form of heat pipes and cold plates and direct liquid cooling in the form of immersion cooling and jet impingement.

*Liquid cooling* can reduce the effective thermal resistance to as low as  $0.01\text{K/W}$ . Both oil and water (which has 4 times the thermal capacity and 770 times the density of air) are used as the coolant and the heat-sink arrangement can either be immersed in the fluid (direct), or the fluid is pumped through a hollow heat sink (indirect). The fluid heat is dissipated remotely. Fluid boiling with direct cooling should be avoided, since the creation of air bubbles can cause local hot spots. Water has the advantage of low viscosity, so can be pumped faster than mineral oil. While oil may be inflammable, water corrodes thus requiring the use of de-ionised water with an oxide inhibitor, like antifreeze (ethylene glycol). Oil emersion has the added advantage of offering possibilities of increasing the breakdown and corona voltage levels, particularly with devices rated and operated at voltages above a few kilovolts.

### 6.6.1 Requirements of a liquid coolant

There are many requirements for a liquid coolant for power electronics applications and vary depending on the type of application. Some of the general requirements are:

- Good thermo-physical properties (high thermal conductivity and specific heat; low viscosity; high latent heat of evaporation for two-phase application)
- Low freezing point and burst point. The burst point (or solidification temperature) is the temperature associated with expansion of a freezing coolant.
- High atmospheric boiling point (or low vapour pressure at the operating temperature) for a single phase system; a narrow desired boiling point for a two-phase system
- Good chemical and thermal stability for the life of the power electronics system
- High flash point and auto-ignition temperature (sometimes non-combustibility is a requirement)
- Non-corrosive to the construction materials (metals as well as polymers and other non-metals)
- No or minimal regulatory constraints (environmentally friendly, non-toxic, and biodegradable)
- Economical

The best electronics coolant is an inexpensive and non-toxic liquid with excellent thermo-physical properties and a long service life. A high flash point and auto-ignition temperature are desired so that the fluid is less susceptible to ignition. Good thermo-physical properties are required to obtain the high heat transfer coefficients and low pumping power needed for the fluid to flow through a tube or a channel.

Electrical conductivity (not mentioned in the list) of a coolant becomes important if the fluid comes in direct contact with the power electronics (such as in direct immersion cooling), or if it leaks out of a cooling loop or is spilled during maintenance and comes in contact with the electrical circuits. In certain applications, a dielectric coolant is necessary, whereas in many other applications it is not a requirement because of the remote chance of coolant leakage (or in case of a leak, the coolant does not come in contact with the power electronics).

The various liquid coolant chemistries are divided into *dielectric* and *non-dielectric fluids* and their properties: refer to Table 6.10 and Table 6.19. Water, deionised water, glycol/water solutions, and dielectric fluids such as fluorocarbons and polyalphaolefins PAO are the heat transfer fluids commonly used in high performance liquid cooling applications. The heat transfer fluid must be compatible with the fluid path, offers corrosion protection or minimal risk of corrosion, and meet the application's specific requirements.

**Table 6.10: Properties of different liquid coolant chemistries at  $20^\circ\text{C}$**

cooling chemistry	freezing point	flash point	viscosity	thermal conductivity	specific heat	density
	$^\circ\text{C}$	$^\circ\text{C}$	$\nu$ $\times 10^{-1} \text{ kg}\cdot\text{m}^{-1}\cdot\text{s}^{-1}$	$\lambda$ $\text{W}\cdot\text{m}^{-1}\cdot\text{s}^{-1}$	$c_p$ $\text{J}\cdot\text{kg}\cdot\text{K}^{-1}$	$\rho_f$ $\text{kg}\cdot\text{m}^{-3}$
Aromatic (DEB)	< -80	57	1	0.14	1700	860
Silicate-ester (coolanol 25R)	< -50	> 175	9	0.132	1750	900
Aliphatic (PAO)	< -50	> 175	9	0.137	2150	770
Silicone (syltherm XLT)	< -110	46	1.4	0.11	1600	850
Fluorocarbon (FC-77)	< -100	none	1.1	0.06	1100	1800
EG/water 50:50 vol	-37.8	none	3.8	0.37	3285	1087
PG/water 50:50 vol	-35	none	6.4	0.36	3400	1062
Methanol/water 40:60 wt	-40	29	2	0.4	3560	935
Ethanol/water 44:56 wt	-32	27	3	0.38	3500	927
Potassium Formate/water 40:60 wt	-35	none	2.2	0.53	3200	1250
Ga-In-Sn	-10	none	2.2	39	365	6363

### 6.6.2 Dielectric liquid coolants

While the food industry might be more likely to select propylene glycol PG over ethylene glycol EG for heat transfer, the power electronics, laser, and semiconductor industries might be more likely to choose dielectric fluids over water. A dielectric fluid is non-conductive and therefore preferred over water when working with sensitive electronics. Perfluorinated carbons, such as dielectric fluid Fluorinert, are non-flammable, non-explosive, and thermally stable over a wide range of operating temperatures. Deionised water is also non-conductive, Fluorinert is less corrosive than deionised water and therefore may be a better choice for some applications. However, water has a thermal conductivity of approximately 0.59W/m°C, while Fluorinert FC-77 has a thermal conductivity of only about 0.063W/m°C. Fluorinert is also much more expensive than deionised water.

Polyalphaolefin, PAO, is a synthetic hydrocarbon used frequently in military and aerospace applications for its dielectric properties and wide range of operating temperatures. PAO compatible recirculating chillers are available for cold plates and heat exchangers that use PAO as the heat transfer fluid. PAO has a thermal conductivity of 0.14 W/m°C. Although dielectric fluids provide low risk liquid cooling for electronics, they generally have a much lower thermal conductivity than water and most water-based solutions.

- **Aromatics:** Synthetic hydrocarbons of aromatic chemistry (that is, diethyl benzene DEB, dibenzyl toluene, diaryl alkyl, partially hydrogenated terphenyl) are common heating and cooling fluids used in a variety of applications. However, these compounds cannot be classified as non-toxic. Also, some of these fluids (namely, alkylated benzene) have strong odours, which can be irritating to the personnel handling them.
- **Silicate-ester:** This chemistry (that is, Coolanol 25R) was widely used as a dielectric coolant in airborne radar and missile systems. These fluids have caused significant and sometimes catastrophic problems due to their hygroscopic nature and subsequent formation of flammable alcohols and silica gel. Therefore, these fluids have been replaced by more stable and dielectric aliphatic chemistry (polyalphaolefins or PAO).
- **Aliphatics:** Aliphatic hydrocarbons of paraffinic and iso-paraffinic type (including mineral oils) are used in a variety of direct cooling of electronics parts as well as in cooling transformers. Many petroleum based aliphatic compounds meet the criteria for incidental food contact. These petroleum-based fluids do not form hazardous degradation by-products. Most of these fluids have a non-discernible odour and are non-toxic in case of contact with skin or ingestion. As mentioned, aliphatic PAO-based fluids have replaced silicate-ester fluids in a variety of military electronics (and avionics) cooling applications in the last decade.
- **Silicones:** Another class of coolant chemistry is dimethyl- and methyl phenyl-poly (siloxane) or commonly known as silicone oil. Since this is a synthetic polymeric compound, the molecular weight and the thermo-physical properties (freezing point and viscosity) can be adjusted by varying the chain length. Silicone fluids are used at temperatures down to -100°C and as high as 400°C. These fluids have excellent service life in closed systems in the absence of oxygen. Also, with essentially no odour, the non-toxic silicone fluids are workplace friendly. However, low surface tension gives these fluids the tendency to leak around pipe-fittings, although the low surface tension improves the wetting property. Similar to the aliphatics, high molecular weight silicone oils are used in cooling transformers.
- **Fluorocarbons:** Fluorinated compounds such as perfluorocarbons (that is, FC-72, FC-77) hydrofluoroethers (HFE) and perfluorocarbon ethers (PFE) have certain unique properties and can be used in contact with the electronics. First, these fluids are non-combustible and non-toxic. Some fluorinated compounds have zero ozone depleting potential and other environmental properties. Second, some of these fluids have low freezing points and low viscosities at low temperatures. However, these fluids are expensive, have poor thermal properties, some have global warming potential (greenhouse effect), and, due to the extremely low surface tension, leaks can develop around fittings.

### 6.6.3 Non-dielectric liquid coolants

Non-dielectric liquid coolants are often used for cooling electronics because of their superior thermal properties, as compared with the dielectric coolants. Non-dielectric coolants are normally water-based solutions. Therefore, they possess a high specific heat and thermal conductivity. De-ionized water is an example of a widely used coolant.

- **Water:** Water is a suitable choice for liquid cooling applications due to its high heat capacity and thermal conductivity. It is also compatible with copper, which is one of the best heat transfer materials to use in the fluid path. Water used for cooling comes from different sources. The benefit of using facility or tap water is that it is readily available and inexpensive. However, facility water or tap water is likely to contain impurities, which cause corrosion in the liquid cooling loop and/or clog fluid channels. Therefore, use good quality water in order to minimize corrosion and optimize thermal performance.

Water's ability to corrode metal can vary considerably depending on its chemical composition. Chloride, for example, is commonly found in tap water and can be corrosive. Facility or tap water should not be used in liquid cooling loops if it contains more than 25ppm of chloride. The levels of calcium and magnesium in the water also need to be considered, since calcium and magnesium form scale on metal surfaces and reduce the thermal performance.

If the facility water or tap water contains a large percent of minerals, salts, or other impurities, the water can be purchased filtered or deionised. If the tap water is relatively pure and meets recommended limits, a corrosion inhibitor should be added for additional protection. Phosphate is an effective corrosion inhibitor for stainless steel and most aluminium components. It is also effective for pH control. One disadvantage of phosphate, however, is that it precipitates with calcium in hard water. For copper and brass, tolyltriazole is an effective corrosion inhibitor. For aluminium, organic acids such as 2-ethyl hexanoic or sebacic acid offer protection.

- **Deionised Water:** Tap water meets the needs of most liquid-cooling applications. However, deionised (DI) water has chemical and electrical properties that make it the optimal choice for cooling when the liquid circuit contains micro-channels or when sensitive electronics are involved. Deionised water is water that has an extremely low concentration of ions, including sodium, calcium, iron, copper, chloride, and bromide. The lack of ions in DI water eliminates the following problems.
  - First, it eliminates mineral, salts and impurities that can cause corrosion or scale formation and block the coolant flow. This will degrade cooling efficiency and system operating performance.
  - Second, it eliminates the risk of electrical arcing due to static charge build up from the circulating coolant. The arcing can damage sensitive control electronics in the equipment being cooled. Compared to tap water and most fluids, deionised water has a high resistivity, and as an excellent insulator, is used in the manufacturing of electrical components where parts must be electrically isolated. However, as water's resistivity increases, its corrosivity increases. Deionised water has a pH of approximately 7.0 but quickly becomes acidic when exposed to air. The carbon dioxide in air dissolves in the water, introducing ions, giving an acidic pH of around 5.0. Therefore, when using water that is virtually pure, it is necessary to use a corrosion inhibitor. When using deionised water in a recirculating chiller, special high purity plumbing is needed. The fittings should be nickel-plated and the evaporators should be nickel-brazed. When using deionised water in cold plates or heat exchangers, stainless steel tubing is recommended. The lack of ions makes this coolant unusually corrosive. Called the 'universal solvent', DI water is one of the most aggressive solvents known. In fact, to a varying degree, it will dissolve everything to which it is exposed. Therefore, all materials in the cooling loop must be corrosion-resistant. Copper and many other common materials are not compatible with DI water and will contaminate it.
- **Ethylene Glycol (EG):** Commonly used as antifreeze in automotive engine cooling, EG also has found use in many industrial cooling applications, at lower temperatures. Ethylene glycol is colourless and practically odourless and is completely miscible with water. Ethylene glycol has desirable thermal properties, including a high boiling point, low freezing point, stability over a wide range of temperatures, and high specific heat and thermal conductivity. It also has a low viscosity and, therefore, reduced pumping requirements. When properly inhibited, it has a relatively low corrosivity. However, this coolant is classified as toxic and should be handled and disposed of with care. Typically, water with low chloride and sulphate ion concentration (<25ppm) is recommended. Also, a monitoring schedule should be maintained to assure that inhibitor depletion is avoided and the pH of the solution is consistent. Once the inhibitor has been depleted, the old glycol should be removed from the system and a new charge installed. Even though EG's thermal conductivity is not as high as water's, EG provides freeze protection that can be beneficial during use or during shipping. Although ethylene glycol is the chemical used in automotive antifreeze, it should not be used in a cooling system or heat exchanger because it contains silicate-based rust inhibitors. These inhibitors can gel and foul, coating heat exchanger surfaces, reducing their efficiency. Silicates have also been shown to reduce significantly the lifespan of pump seals. While the wrong inhibitors can cause significant problems, the right inhibitors can prevent corrosion and significantly prolong the life of a liquid cooling loop. Inhibited glycols are recommended over non-inhibited glycols.

As the concentration of glycol in the solution increases, the thermal performance of the heat transfer fluid decreases. Therefore, it is best to use the lowest possible concentration of inhibited glycol necessary to meet corrosion and freeze protection needs. Dow Chemical recommends a minimum concentration of 25 to 30% EGW4. At this minimum concentration, the ethylene glycol also serves as a bactericide and fungicide. With recirculating chillers, a solution of 30% ethylene glycol results in only a 3% drop in thermal performance over using water alone but will provide corrosion protection as well as freeze protection down to -15°C.

The quality of the water used in the glycol solution is also important. Even with an inhibited glycol, water ions can cause inhibitor precipitation, resulting in fouling and corrosion.

- **Propylene Glycol (PG):** In its inhibited form, PG has the same advantages of low corrosivity shown by ethylene glycol. In addition, propylene glycol is considered non-toxic. Other than lack of toxicity, it has no advantages over ethylene glycol, being higher in cost and more viscous. Although EG has more desirable physical properties than PG, PG is used in applications where toxicity might be a concern. PG is generally recognized as safe for use in food or food processing applications, and can also be used in enclosed spaces.
- **Methanol/Water:** This is a low cost antifreeze solution, finding use in refrigeration services and ground source heat pumps. Similar to glycols, it can be inhibited to stop corrosion. This fluid can be used down to  $-40^{\circ}\text{C}$  owing to its relatively high rate of heat transfer in this temperature range. Its main disadvantages as a heat transfer fluid are its toxicological considerations. It is considered more harmful than ethylene glycol and consequently has found use only for process applications located outdoors. Also, methanol is a flammable liquid and, as such, introduces a potential fire hazard where it is stored, handled, or used.
- **Ethanol/Water:** This is an aqueous solution of denatured grain alcohol. Its main advantage is non-toxicity. Therefore, it has found application in breweries, wineries, chemical plants, food freezing plants, and ground source heat pumps. As a flammable liquid, it requires certain precautions for handling and storage.
- **Calcium Chloride Solution:** Aqueous solutions of calcium chloride are used as circulating coolants in food plants. It is non-flammable, non-toxic and thermally more efficient than the glycol solutions. A 29% (by weight) calcium chloride solution has a freezing point below  $-40^{\circ}\text{C}$ . The main disadvantage of this coolant is that it is highly corrosive, even in the presence of corrosion inhibitors.
- **Potassium Formate/Acetate Solution:** Aqueous solutions of potassium formate and acetate salts are non-flammable and non-toxic as well as much less corrosive and thermally more efficient than calcium chloride solution. Therefore, even a with higher price than calcium chloride, they have found a large number of applications, in the food, beverage, pharmaceuticals, chemical and climatic chamber applications, and single-phase convection cooling of microprocessors.
- **Liquid Metals:** Liquid metals of Ga-In-Sn chemistry are utilized with a magneto-fluid-dynamic (MFD) pump. It utilizes the high thermal conductivity and density of the metal alloy to remove high heat flux from the heat source.

## 6.7 Direct and indirect liquid cooling

Application of liquid cooling for power electronics may be categorized as either indirect or direct.

*Indirect liquid cooling* is one in which the liquid does not contact the power electronic chips, nor the substrate upon which the chips are mounted. In such cases, a good thermal conduction path is provided from the power electronic heat sources to a liquid cooled cold-plate attached to the module surface, as shown in Figure 6.17. Since there is no contact with the electronics, water can be used as the liquid coolant, taking advantage of its superior thermo-physical properties.

*Direct liquid cooling* involves the components to be cooled being immersed in and in direct contact with the cooling fluid, as with oil-immersed transformers.

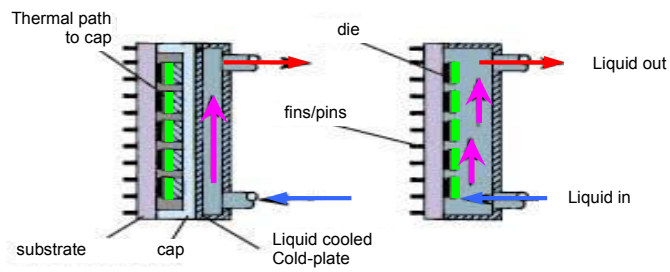

Figure 6.17. Example of indirect and direct liquid immersion cooling for a disk package.

## 6.8 Indirect liquid cooling

### 6.8.1 Heat pipes – indirect cooling

Heat pipes provide an indirect and passive (no moving parts) means of applying liquid cooling. It is a two-phase device (evaporation-condensation). A heat pipe can be used in situations when a heat source and a heat sink need to be placed apart.

There are several common types of heat pipes, including:

- **Vapor chamber:** These flat heat pipes are typically used when heat fluxes and high powers are applied to smaller evaporators, as well as for enabling heat flow through very thin devices.
- **Variable conductance:** Adding a non-condensable gas that mixes with working fluid vapor and a reservoir, creates a Variable Conductance Heat Pipe, where the effective thermal conductivity varies with the input power and heat sink conditions.
- **Diode:** Diode heat pipes are designed to transfer heat in one direction, and insulate it in the opposite direction.
- **Loop heat pipe:** This is a passive two-phase device that is capable of transferring higher power over longer distances.

They are vacuum pumped (evacuated) and sealed vessels that are partially filled with a liquid, usually high purity water or alcohol in a saturated vapour form. The internal walls of the pipes are lined with a porous medium (the wick) that acts as a passive capillary pump. When heat is applied to one end of the pipe (evaporator), the liquid starts evaporating. A pressure gradient exists causing the vapour to flow to the fractionally cooler regions. The vapour condenses (with the latent heat of vaporisation transferred to the condenser) back to the liquid state at the cooler regions and is transported back by the capillary wick structure (or gravity), thereby closing the fluid two-state thermodynamic loop.

This thermodynamic cycle can be summarised, with the aid of figure 6.18, as follows:

**Stage 1-2:** Heat applied to the evaporator through the external source vaporizes the working fluid to a saturated (2') or superheated (2) vapour.

**Stage 2-3:** Vapour pressure drives vapour through the adiabatic section to the condenser.

**Stage 3-4:** Vapour condenses, releasing heat to a heat sink.

**Stage 4-1:** Capillary pressure created by wick menisci pumps condensed fluid into evaporator section. Then the continuously circulating process starts over.

The thermosyphon differs from the heat pipe in having no wick. The device can therefore only operate with the condenser above the evaporator with gravity-assist liquid flow return. The viscous and sonic limits are the same as for wicked heat pipes.

Heat pipes provide an enhanced means of transporting heat, much better than copper, from a source to a heat sink where it is rejected to the cooling medium by natural or forced convection. The effective thermal conductivity of a heat pipe can range from  $50\text{kW/mK}$  to  $200\text{kW/mK}$ , but is often lower in practice due to additional interface thermal resistances. The performance of heat pipes scales from  $10\text{ W/cm}^2$  to over  $300\text{ W/cm}^2$ . A simple water-copper heat pipe has an average heat transfer capacity of  $100\text{ W/cm}^2$ , a thermal conductivity that is in excess of 300 times better than that of an equivalently sized pure copper component. A heat pipe provides efficient transport of concentrated heat. An example of a typical application of a heat pipe for an electronics cooling application is given in Figure 6.19.

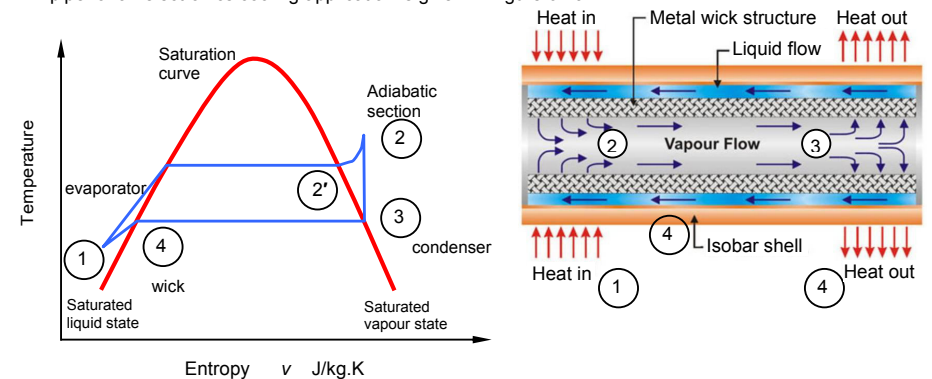

Figure 6.18. Heat pipe thermodynamic  $T$ - $v$  operational vapour power cycle.

Heat pipes are an energy-efficient, flexible, light-weight, low-cost, reliable, passive, silent, high thermal conducting, evacuated, sealed cylindrical device for quickly extracting, transporting, and remotely dissipating heat, in any orientation.

Although there is virtually no limit to the size of a heat pipe, the effectiveness of a heat pipe decreases with decreasing lengths. For heat pipes with a length less than about 1 cm the performance of a solid piece of metal, copper, is comparable. They are effective as efficient heat conductors to transport heat to locations where more area is available. 2D heat spreaders (otherwise known as vapour chambers) based on the heat pipe principle can achieve much higher effective thermal conductivities than copper. A thin planar heat spreader has a thermal performance greater than diamond.

Loop heat pipes (LHP) have the advantage over conventional heat pipes that the vapour and liquid paths are separated enabling much better performance of the liquid return loop, accommodate a heat flux of  $625\text{W}/\text{cm}^2$ .

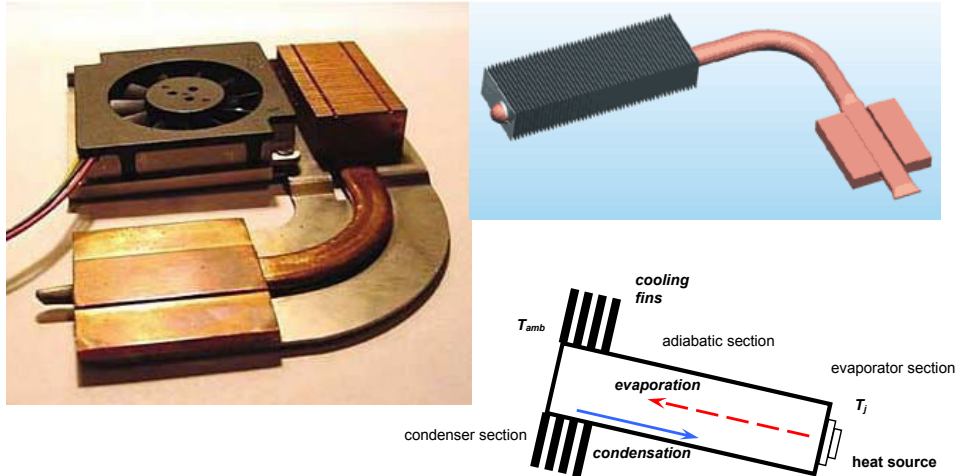

Figure 6.19. Example of heat pipes used in a notebook application.

A heat pipe is designed for a certain temperature range. Apart from the vapour temperature range, factors like thermal stability and thermal conductivity influence the choice of working fluid. Suitable working fluids, which desirably have a high surface tension, include (see figure 6.25):

- For ultra low temperatures: inert gases (helium), nitrogen, ammonia
- For usual temperatures to meet power electronics cooling requirements: distilled water with various additions, organic fluids like acetone, methanol, ethanol, and toluene.
- For high temperatures: metals like mercury, sodium, silver.

The component to be cooled is mounted on the evaporator end (the hot end), where the heat boils and expands the liquid to the vapour phase, increasing the pressure. Boiling occurs because energy, in the form of heat, is taken from the surrounding area, which cools the heat source. This vapour rises through the adiabatic tube section (low-pressure drop, hence low temperature change) to the remote condenser end of the tube (the cold end), taking the heat within it. Effectively the heat is transported at the rate  $P$ :

$$P = L \frac{dm}{dt}$$

where  $L$  is the heat of vaporization per unit mass and  $dm/dt$  is the mass evaporation rate.

The vapour condenses back to the liquid phase, releasing its latent heat of vaporisation, and creates a pressure gradient, which helps draw more vapour towards the condenser. The temperature difference between the ends may only be a couple of degrees. The remotely situated condenser end is connected to an external heatsink or a radiator type grill, for cooling. The condensed working fluid runs back to the evaporator end due to gravity, or due to capillary pressure action, along porous capillaries that form a wick, depending on the physical application orientation design for the heat pump.

The quality and type of wick usually determines the performance of the heat pipe.

The wick is a porous structure made of materials like steel, aluminium, nickel or copper in various ranges of pore sizes. They are fabricated using metal foams, and more commonly, felts. By varying the pressure on the felt during assembly, various pore sizes can be produced. By incorporating removable metal mandrels, an arterial structure can be moulded in the felt.

The two most important properties of a wick are the pore radius and the permeability. The pore radius determines the pumping pressure (the maximum capillary head) the wick can develop. The wick permeability increases with increasing pore size. The permeability determines the frictional losses of the fluid as it flows through the wick. The heat transport capability of the heat pipe is raised by increasing the wick thickness. The overall thermal resistance at the evaporator also depends on the conductivity of the working fluid in the wick.

There are several types of wick (capillary) structures available including (decreasing permeability and decreasing pore radius): grooves, screen, cables/fibred, and sintered powder metal, shown in figure 6.20 and summarized in Table 6.11. Specifically:

**Sintered powder:** This wick provides high power handling, low temperature gradients, and high capillary forces for anti-gravity applications. The complex sintered wick has several vapour channels and small arteries to increase the liquid flow rate. Tight bends in the heat pipe can be achieved with this type of structure.

**Grooved tube:** The small capillary driving force generated by the axial grooves is adequate for low power heat pipes when operated horizontally, or with gravity assistance. The tube can be readily bent. When used in conjunction with screen mesh the performance can be enhanced.

**Screen mesh:** This type of wick is the most common and provides readily variable characteristics in terms of power transport and orientation sensitivity, according to the number of layers and mesh counts used.

**Fibre/spring:** Fibrous materials, like ceramics, generally have smaller pores. The main disadvantage of ceramic fibres is minimal stiffness and requires support by a metal mesh. Carbon fibre filaments have many fine longitudinal grooves on their surface, have high capillary pressures, are chemically stable, and show a greater heat transport capability.

Table 6.11: Wick material properties

Wicking Material	Conductivity (Straight)	Overcome Gravity	Thermal Resistance	Stability	Conductivity lost (bended and flatten)
Axial Groove	Good	Poor	Low	Good	Low/Average
Screen Mesh	Average	Average	Average	Average	Low/Average
Fine Fibre	Poor	Good	High	Poor	Average
Sintering (powder)	Average	Excellent	High	Average	High

Since grooved wicks have a large pore radius and a high permeability, the pressure losses are low but the pumping head is also low. Grooved wicks can transfer high heat loads in a horizontal or gravity aided position, but cannot transfer large loads against gravity. The powder metals have small pore radii and relatively low permeability. Powder metal wicks are limited by pressure drops in the horizontal position but can transfer large loads against gravity.

An advantage of the sintered powder wick is its ability to handle high heat fluxes. Since sintered powder wicks are generally 50% porous, there is accordingly a large surface area available for evaporation. Typical sinter powder wicks handle  $50\text{W}/\text{cm}^2$ , and up to  $250\text{W}/\text{cm}^2$ . In comparison, a groove wick nominally handles  $5\text{W}/\text{cm}^2$  and a screen wick will nominally handle  $10\text{W}/\text{cm}^2$ . Since a sintered powder wick is integral with the heat pipe envelope, and the fluid charge is only enough to saturate the wick, the heat pipe can be subjected to freeze/thaw cycles with no degradation in performance.

#### Working fluid or coolant

A first consideration in the identification of a suitable working fluid is the operating vapour temperature range. Within the approximate temperature band, several possible working fluids may exist, and a variety of characteristics must be examined in order to determine the most acceptable of these fluids for the application considered. The prime requirements are:

- compatibility with wick and wall materials
- good thermal stability
- wettability of wick and wall materials
- vapour pressure not too high or low over the operating temperature range
- high latent heat
- high thermal conductivity
- low liquid and vapour viscosities
- high surface tension
- acceptable freezing or pour point



The typical temperature operating range is within the bounds -55°C to over 200°C, depending on the coolant, as shown in Table 6.12 (see figure 6.25). Heat pipes can be designed to operate over a broad range of temperatures from cryogenic (< -243°C) applications utilizing titanium alloy/nitrogen heat pipes, to high temperature applications (>2000°C) using tungsten/silver heat pipes. In power electronic cooling applications where junction temperatures below 125°C to 150°C are desired, copper/water heat pipes are used. Copper/methanol heat pipes are used if the application requires heat pipe operation (and importantly, start up) below 0°C. Water heat pipes, with a temperature range from 5°C to 230°C, are less sensitive than methanol to orientation, and are most effective for power electronics cooling applications, plus copper vessels are compatible with water.

**Table 6.12: Heat pipe fluids, in increasing operating temperature range (see Table 6.18)**

Medium	Melting point °C	Boiling pt @ atm pressure °C	Measured axial heat flux kW/cm <sup>2</sup>	Measured surface heat flux W/cm <sup>2</sup>	Vessel material	Operating range °C
Carbon dioxide					Al, Ti, stainless steel	-50 to 30
Helium (t)	- 271	- 261			Stainless steel, Ti	-271 to -269
Nitrogen (t)	- 210	- 196	0.067 @ -163°C	1.01 @ -163°C	Stainless steel	-200 to -120
Ammonia (t)	- 78	- 33	0.295	2.95	Ni, Al, stainless steel	-70 to 120
Acetone	- 95	57			Cu, Ni, Al, stainless steel	0 to 120
Methanol	- 98	64	0.45 @ 100°C	75.5 @ 100°C	Cu, Ni, stainless steel	-65 to 120
Flutec PP2	- 50	76				10 to 160
Ethanol	- 112	78				0 to 130
Water	0	100	0.67 @ 200°C	146 @ 170°C	Cu, Ni, Ti, Monel	5 to 230
Toluene	- 95	110			Al	50 to 200
Mercury/Mg	- 39	361	25.1 @ 360°C	181 @ 360°C	Stainless steel	190 to 600
Potassium	63	759	5.6 @ 750°C	181 @ 750°C	Stainless steel, Ni, Inconel	400 to 950
Sodium	98	892	9.3 @ 850°C	224 @ 760°C	Stainless steel, Ni, Nb, Haynes	500 to 1100
Lithium	179	1340	2 @ 1250°C	207 @ 1250°C	W, Ti, Niobium +1% Zirconium	900 to 1800
Silver	960	2212	4.1	413	Tantalum +5% Tungsten	1600 to 2200

The capillary or lifting height  $H$  is given by

$$H = \frac{2\gamma \cos \theta}{r_c g_f \rho_f} \tag{6.21}$$

where  $\gamma$  is the surface tension, N/m, unique for each working fluid at certain temperatures,  $\theta$  is the contact angle, rad, differs for each working fluid,  $r_c$  the effective capillary radius, m, is a unique characteristic of the wick type used,  $g_f$  is the gravitational acceleration, m/s<sup>2</sup>, assumed constant, and  $\rho_f$  is the working fluid density, kg/m<sup>3</sup>, dependant on the application conditions.

The heat power transfer capabilities (axial power rating, APR) of a heat pipe are related to its cross-sectional area  $A_x$  and length  $l$  according to equation 5.3

$$P_D = k \frac{A_x}{l} \tag{W} \tag{6.22}$$

while the temperature difference  $\Delta T$  between the hot and cold ends is

$$\Delta T = k' P_D \left( \frac{1}{A_e} + \frac{1}{A_c} \right) \tag{K} \tag{6.23}$$

where  $A_e$  and  $A_c$  are the effective evaporator and condenser surface areas.

As a heat pipe has no moving parts, its mttf is estimated to be over 100,000 hours of use. Improper bending and flattening of the pipe may cause leakage at the pipe seal. There are some external factors that may also shorten the life of a heat pipe such as shock, vibration, force impact, thermal shock, and corrosive environment.

Unlike Peltier elements (see 6.13.1):

- a heat pipe does not consume energy or produce heat itself and
- it is not possible to cool a device below ambient temperature using a heat pipe.

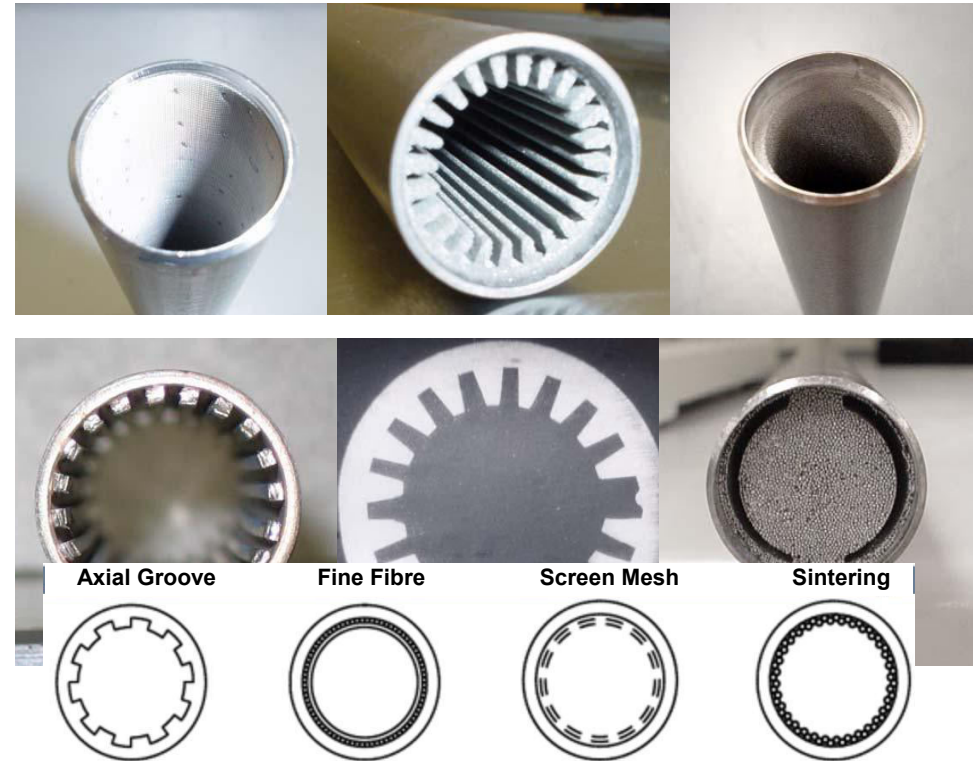

Figure 6.20. Examples of heat pipes wicks.

A solid rod of copper conducts heat by diffusion, and a constant, geometry-independent thermal conductivity can be defined for the material. A heat pipe, however, conducts heat by transport of the vapour and therefore is more correctly thought of as a heat carrying device rather than a simple thermal resistor. A heat pipe carries heat with a certain temperature drop  $\Delta T$ , but  $\Delta T$  is virtually independent of the length of the heat pipe. Thus, heat pipes not only have low thermal resistance  $R$  (small  $\Delta T$ ) but also have the property that  $R$  is roughly independent of length. The advantage of using a heat pipe, rather than a rod of Cu metal, therefore increases with increasing length. The heat transfer or transport capacity of a heat pipe is specified by its *Axial Power Rating* APR. This is the energy moving axially along the pipe. As in equation (6.22), the larger the heat pipe diameter, the higher the APR, while the longer the heat pipe, the lower the APR.

The fact that the heat pipe functions at all in an 'upside-down' orientation, as shown in figure 6.23, is due to the wicking of the condensed fluid against gravity.

There are five primary heat-pipe heat transport limitations, summarized in Table 6.13, which are a function of the heat pipe operating temperature, as shown in figure 6.21:

- **Viscous limit** – Heat pipes will not function when the pipe temperature is lower than the freezing point (zero viscosity) of the working fluid. At low temperatures (just above freezing), the vapour pressure difference between the condenser and the evaporator may not be enough to overcome viscous forces. The vapour from the evaporator cannot move to the condenser and thus the thermodynamic cycle does not occur. Freezing and thawing may destroy the sealed joint of a heat pipe when placed vertically.
- **Sonic limit** – The rate that vapour travels from the evaporator to the condenser. The limit occurs when the vapour velocity reaches sonic speed at the evaporator and any increase in pressure difference cannot speed up the flow. This usually occurs during heat pipe start-up.
- **Entrainment or flooding limit** – Friction between the working fluid and vapour that travel in opposite directions. At high vapour velocities, droplets of liquid in the wick are extracted from the wick and deposited into the vapour. This results in dry-out.
- **Capillary pumping limit** – the rate at which the working fluid travels from the condenser to the evaporator through the wick. This limit occurs when the capillary pressure is too low to provide enough liquid to the evaporator from the condenser. This leads to evaporator dry-out, which prevents continuing the thermodynamic cycle and the heat pipe no longer functions properly.
- **Nucleated boiling limit** – the rate at which the working fluid vaporizes from the added heat. This limit occurs when the radial heat flux into the heat pipe causes the liquid in the wick to boil and evaporate causing dry-out.

Each limit has its own particular range of importance. However, in practice, the capillary and boiling limits are the most important. Figure 6.21 illustrates the five limitation boundaries.

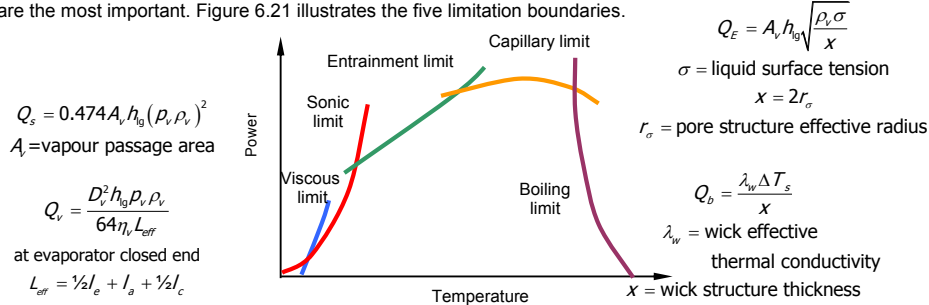

Figure 6.21. Heat transport limitation boundaries of a heat pipe.

For a heat pipe to function, the net capillary pressure difference between the evaporator (heat source) and condenser (heat sink) must be greater than the sum of all pressure losses occurring along the liquid and vapour flow paths. This relationship, termed the **capillary limitation**, and for correct operation:

$$\Delta P_{c,max} \geq \Delta P_{liquid} + \Delta P_{vapour} + \Delta P_g \tag{6.24}$$

where  $\Delta P_{c,max}$  is the maximum capillary pressure difference generated within the capillary wicking structure between the evaporator and condenser ( $2\sigma \cos\theta / r_c$ ),  $\Delta P_{liquid}$  is the viscous pressure drops occurring in the liquid, to return the liquid from the condenser to the evaporator,  $\Delta P_{vapour}$  is the viscous pressure drops occurring in the vapour, to cause the vapour to flow from the evaporator to the condenser,  $\Delta P_g$  represents the hydrostatic pressure drop due to the gravitational head,  $\rho_l g l \sin\phi$ .

Table 6.13: Heat-pipe mechanisms and limitations

Heat Transport Limit	Description	Cause	Potential Solution
Viscous (vapour pressure)	Viscous forces prevent vapour flow in the heat pipe	Heat pipe operating below recommended operating temperature	Increase heat pipe operating temperature or find alternative working fluid
Sonic	Vapour flow reaches sonic velocity when exiting heat pipe evaporator resulting in a constant heat pipe transport power and large temperature gradients	Power/temperature combination, too much power at low operating temperature	This is typically only a problem at start-up. The heat pipe will carry a set power and the large $\Delta T$ will self correct as the heat pipe warms up
Entrainment/Flooding	High velocity vapour flow prevents condensate from returning to evaporator	Heat pipe operating above designed power input or at too low an operating temperature	Increase vapour space diameter or operating temperature

Capillary (circulation)	Sum of gravitational, liquid and vapour flow pressure drops exceed the capillary pumping head of the heat pipe wick structure	Heat pipe input power exceeds the design heat transport capacity of the heat pipe	Modify heat pipe wick structure design or reduce power input
Boiling	Film boiling in heat pipe evaporator typically initiates at 5-10 W/cm <sup>2</sup> for screen wicks and 20-30 W/cm <sup>2</sup> for powder metal wicks	High radial heat flux causes film boiling resulting in heat pipe dry-out and large thermal resistances	Use a wick with a higher heat flux capacity or spread out the heat load

When the maximum capillary pressure is equal to or greater than the sum of these pressure drops, the capillary structure returns an adequate amount of working fluid (priming or repriming of the heat pipe) to prevent the evaporator wicking structure from drying out. When the sum of all pressure drops exceeds the maximum capillary pumping pressure, the working fluid is not supplied rapidly enough to the evaporator to compensate for the liquid loss through vaporization, and the wicking structure becomes starved of liquid and dries out (depriming of the heat pipe). This condition, referred to as **capillary limitation**, varies according to the wicking structure, working fluid, evaporator heat flux, operating temperature, and body forces.

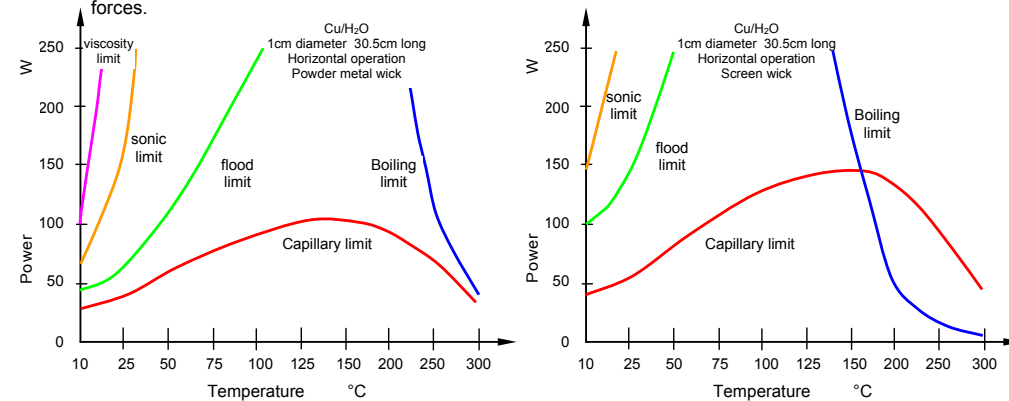

Figure 6.22. Predicted heat pipe limitations, where the capillary limit is usually the limiting factor: (a) powder metal wick and (b) screen wick (viscosity limit on y-axis off-scale). Note temperature scale entrainment.

Figure 6.22 shows graphs of the axial heat transport limits as a function of operating temperature for typical powder metal and screen wicked heat pipes. The capillary limit is usually the limiting factor in a heat pipe design, when used in its optimal temperature range, and this limit is set by the pumping capacity of the wick structure. As shown in Figure 6.23, the capillary limit is a function of the operating orientation and the type of wick structure.

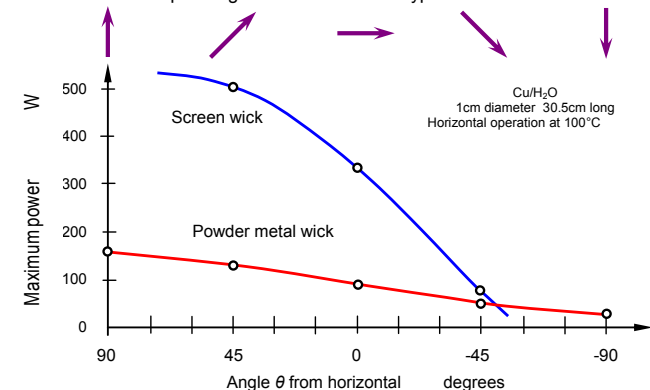

Figure 6.23. Dependence of maximum stable heat flow on orientation, specifically capillary limits versus operating angle. Arrows indicate the direction of the heat flow.



### Heat pipe effective thermal resistance

A primary heat pipe design consideration is effective pipe thermal resistance or overall heat pipe  $\Delta T$  at a given design power. As the heat pipe is a two-phase heat transfer device, a constant effective thermal resistance value cannot be assigned. The effective thermal resistance is not constant but a function of many variables, such as heat pipe geometry, evaporator length, condenser length, wick structure, and working fluid.

The total thermal resistance of a heat pipe is the sum of the resistances due to

- conduction through the wall,
- conduction through the wick,
- evaporation or boiling, axial vapour flow,
- condensation, and
- conduction losses back through the condenser section wick and wall.

Because heat pipes are two-phase heat transfer devices that do not have relatively constant thermal conductivities like solid materials, an effective thermal conductivity is used. The equation used to calculate the effective thermal conductivity for a heat pipe is:

$$\lambda_{\text{eff}} = \frac{P_T \times L_{\text{eff}}}{A_x \times \Delta T} = \frac{1}{R_{\theta}} \times \frac{L_{\text{eff}}}{A_x} \quad (6.25)$$

where:  $L_{\text{eff}} = \frac{1}{2} L_{\text{evaporator}} + L_{\text{adiabatic}} + \frac{1}{2} L_{\text{condenser}}$

$\lambda_{\text{eff}}$  = thermal conductivity

$A_x$  = the cross-sectional area of the heat pipe

$P_T$  = power transported by the heat pipe

$\Delta T$  = the measured temperature difference across the heat pipe.

A few rules of thumb can be used for first pass design considerations. A rough guide for a copper/water heat pipe with a powder metal wick structure is to use  $0.2^\circ\text{C}/\text{W}/\text{cm}^2$  for thermal resistance at the evaporator and condenser, and  $0.02^\circ\text{C}/\text{W}/\text{cm}^2$  for axial resistance.

The evaporator and condenser thermal resistances are based on the outer surface area of the heat pipe. The axial thermal resistance is based on the cross-sectional area of the vapour space. This design guide is only useful for powers at or below the design power for the given heat pipe.

These equations for thermal performance are only rule of thumb guidelines and should only be used to help determine if heat pipes will meet your cooling requirements, not as final design criteria.

The groove heat pipe has the lowest capillary limit among the four but functions best under gravity-assisted conditions.

#### Example 6.4: Heat-pipe

To calculate the effective thermal resistance for a 1.27 cm diameter copper/water heat pipe 30.5 cm long with a 1 cm diameter vapour space, the following assumptions are made.

The heat pipe is dissipating 75W with 5cm evaporator and 5cm condenser lengths.

#### Solution

The evaporator heat flux  $p$  equals the power  $P_T$  divided by the heat input area

$$p_{\text{evap}} = \frac{P_T}{A_{\text{evap}}} = \frac{P_T}{\pi D_o L_{\text{evap}}} = \frac{75\text{W}}{\pi \times 1.27\text{cm} \times 5\text{cm}} = 3.8\text{W}/\text{cm}^2$$

$$p_{\text{cond}} = \frac{P_T}{A_{\text{cond}}} = \frac{P_T}{\pi D_o L_{\text{cond}}} = \frac{75\text{W}}{\pi \times 1.27\text{cm} \times 5\text{cm}} = 3.8\text{W}/\text{cm}^2$$

The axial heat flux equals the power divided by the cross sectional area of the vapour space

$$p_{\text{axial}} = \frac{P_T}{A_{\text{axial}}} = \frac{P_T}{\frac{1}{4} \pi D_i^2} = \frac{75\text{W}}{\frac{1}{4} \pi \times 1.0^2} = 95.5\text{W}/\text{cm}^2$$

The temperature gradient equals the heat flux times the thermal resistance.

$$\Delta T = p_{\text{evap}} \times R_{\text{evap}} + p_{\text{axial}} \times R_{\text{axial}} + p_{\text{cond}} \times R_{\text{cond}}$$

$$\Delta T = 3.8 \text{ W}/\text{cm}^2 \times 0.2^\circ\text{C}/\text{W}/\text{cm}^2 + 95.5 \text{ W}/\text{cm}^2 \times 0.02^\circ\text{C}/\text{W}/\text{cm}^2 + 3.8 \text{ W}/\text{cm}^2 \times 0.2^\circ\text{C}/\text{W}/\text{cm}^2$$

$$\Delta T = 3.4^\circ\text{C}$$

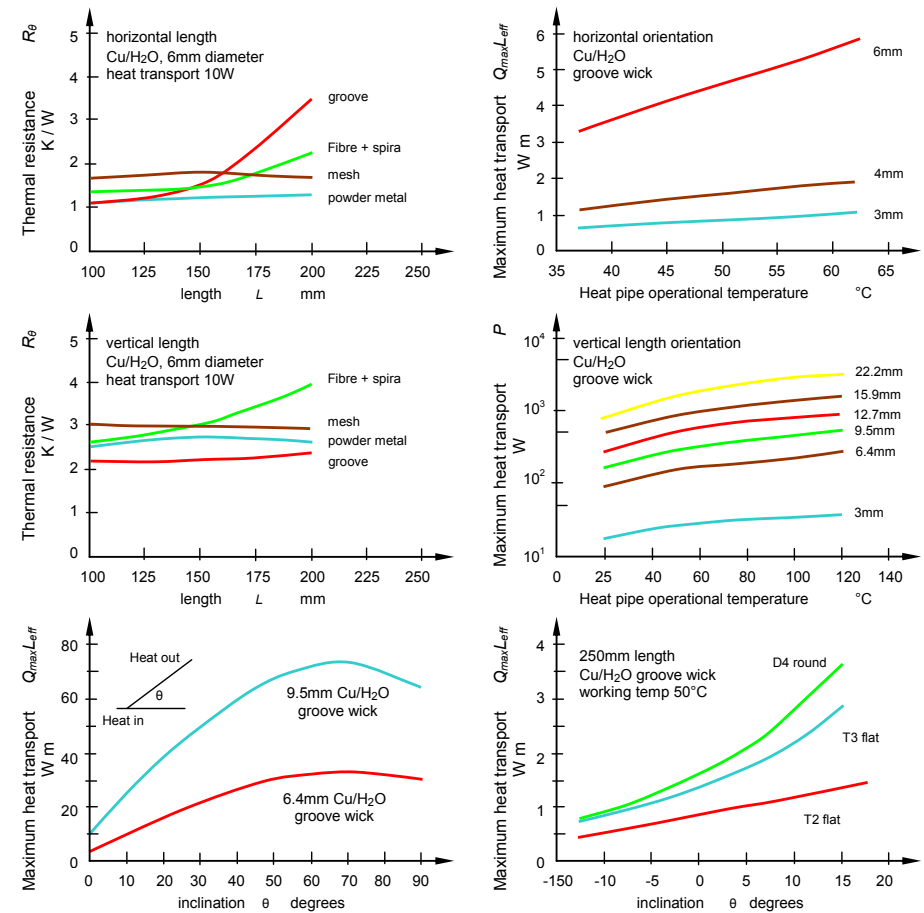

Figure 6.24. Heat pipe parameter performance characteristics.

#### Length and diameter affect on heat pipe performance

The rate of vapour travelling from the evaporator to the condenser is governed by the difference in vapour pressure between them. It is also affected by the diameter and the length of the heat pipe. In a large diameter heat pipe, the large cross sectional area allows a higher vapour volume to be transported from the evaporator to the condenser, than in a small diameter pipe. The cross sectional area of a heat pipe is a direct function of both the sonic and entrainment limits of the heat pipe. However, the operational temperature of the heat pipe also affects the sonic limit of the heat pipe. Figure 6.24 compares the heat transport for heat pipes with different diameters and shows that the heat pipes transport more heat at higher operational temperatures.

The rate at which the working fluid returns from the condenser to the evaporator is governed by the capillary limit and is a reciprocal function of the heat pipe's length. A longer heat pipe transports less heat than shorter heat pipes. In figure 6.24,  $Q_{\text{max}} L_{\text{eff}}$  (W.m), that is, Y-axis, represents the amount of heat a pipe will carry per meter length. Therefore, if the pipe is half a meter, it can carry twice the wattage a metre long heat pipe would carry.

#### Orientation affect on heat pipe performance

A wick structure with a higher capillary limit can transport more working fluid from the condenser to the evaporator against gravity. But as mentioned, the groove heat pipe, with the lowest capillary limit, works best under gravity-assisted conditions where the evaporator is located below the condenser. Figure 6.24 shows the effect of gravity on groove wick heat pipes.

**Performance affect of heat pipe flattening or bending**

If a heat pipe is flattened or bent, the sonic and entrainment limits will be reduced in relation to the flattened thickness, the number of bends, and the angle of each bend. Therefore, any flattening or bending to a heat pipe will reduce the amount of heat that can be transported. Figure 6.24 shows the effect of flattening on a heat pipe.

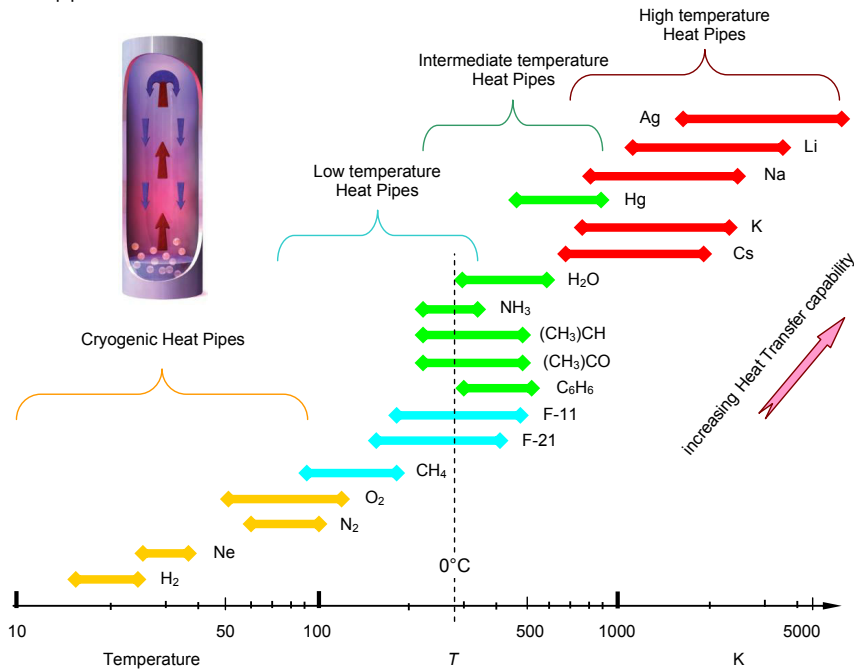

Figure 6.25. Operating temperature ranges for various heat pipe fluids.

**Operating temperature range**

The operating temperature ranges of heat pipes are referred to as *Cryogenic* (0 to 100K), 'Low Temperature' (100K to 250K), 'Intermediate Temperature' (250K to 600K), and 'High Temperature' (600K to 3000K). Working fluids are elemental gases in the cryogenic range, mainly polar molecules or halocarbons in the low temperature range, simple organic molecules in the intermediate temperature range, and liquid metals in the high temperature range.

The approximate useful heat pipe fluid range of some working fluids is indicated in Figure 6.25. Also indicated are the limits of the four defined temperature regimes. The range limits are approximate since some of the fluids overlap into an adjacent temperature range.

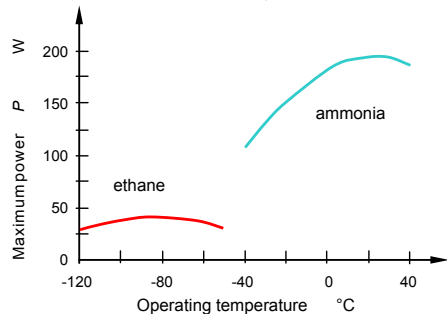

Figure 6.26. Low temperature constant conductance heat pipe performance for Al/NH<sub>3</sub> and Al/C<sub>2</sub>H<sub>6</sub> with slight adverse elevation, 12mm internal diameter, 60cm adiabatic section and 15cm evaporator/condenser.

**Low temperature heat pipe technology**

Low order hydrocarbons are common low temperature heat pipe fluids, as specifically shown for ethane (in stainless steel) and ammonia (in an aluminium alloy) based constant conductance heat pipes in figure 6.26. In the operating range -30°C (243K) to -60°C (213K), copper-acetone is effective.

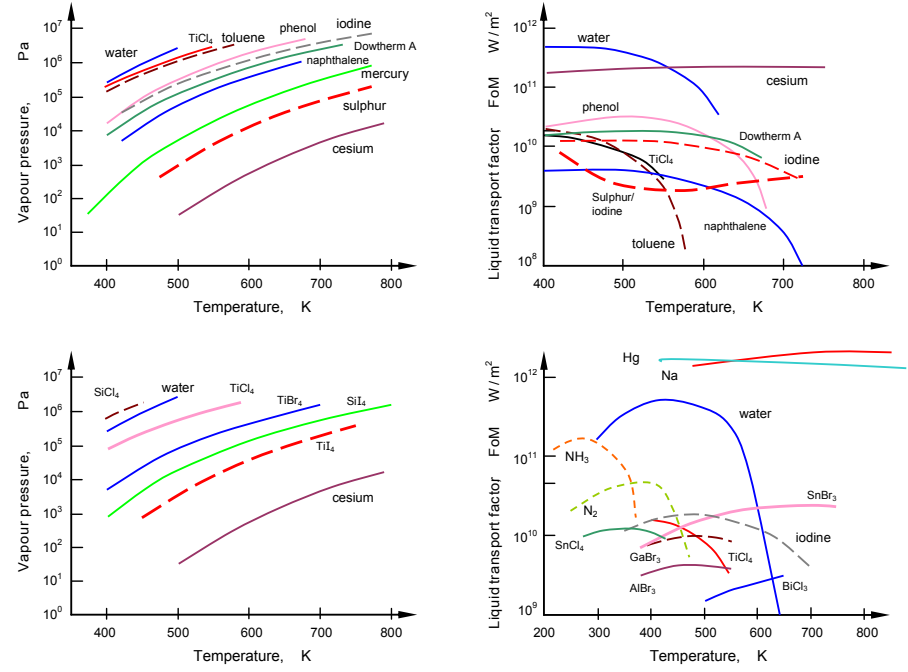

Figure 6.27. Vapour pressure and figure of merit for intermediate temperature heat-pipe fluids, at a constant latent heat and normal boiling temperature.

**Intermediate temperature heat pipe technology**

The intermediate temperature range extends from 450K to 750K. The alkali metals, such as caesium, potassium, and sodium, are suitable working fluids at temperatures above this range. In the intermediate temperature range, the alkali metal vapour density is so low that the vapour sonic velocity limits the heat transfer, and the heat pipe vapour space becomes too large to be practical for alkali metals.

Water is commonly used at temperatures up to about 425K. Higher temperature water heat pipes can be used with titanium or Monel envelopes at temperatures up to 500K. Their effectiveness starts to fall off after 500K, due to the decrease in the surface tension of water. Potential intermediate temperature working fluids including Sulphur/Iodine mixtures, Iodine, Naphthalene, Phenol, Toluene, Mercury, and several halides. Sulphur has a temperature dependent polymerization property at 475K, which increases its liquid viscosity to approximately three orders of magnitude higher than the maximum level for effective heat pipe operation. The addition of 3-10% of iodine reduces the viscosity of sulphur to a level sufficient for effective heat pipe operation. A disadvantage of iodine is its low liquid thermal conductivity.

Another set of potential working fluids is the halide salts of titanium, aluminium, boron, phosphorus, and silicon. Salts such as TiCl<sub>2</sub>F<sub>2</sub> working fluids are polar, which increases the latent heat and the liquid transport factor.

Vapour Pressure and Merit Number are two parameters used to screen potential working fluids. Vapour pressures for some intermediate temperature working fluids are shown in the parts of Figure 6.27. Note that the vapour pressure for water is too high, and the vapour pressure for caesium is too low in this temperature range, so a vapour pressure between these two extremes is desirable. Most of the fluids discussed have a suitable vapour pressure.

The Merit Number (liquid transport factor)  $M_l$  is a means of ranking heat pipe fluids, with a higher merit number being more desirable:

$$M_l = \frac{\rho_l \sigma \lambda}{\nu} \tag{6.26}$$

where:  $M_f$  = Merit Number,  $W/m^2$   
 $\rho_f$  = liquid density,  $kg/m^3$   
 $\sigma$  = surface tension,  $N/m$   
 $\lambda$  = latent heat,  $J/kg$   
 $\nu$  = liquid viscosity,  $Pa$

Figure 6.27 shows the Merit Number as a function of temperature for a number of fluids. Whilst water and caesium have good merit numbers, their vapour pressures eliminate them from contention.

Figure 6.28 compares the theoretical heat transfer capability (power) for heat pipes with five working fluids: water, iodine,  $BiCl_3$ ,  $SbBr_3$ , and caesium. Water is the best fluid at the low temperature end and caesium at the upper end. Iodine and  $SbBr_3$  offer good performance in the mid-region. However, Iodine has two potential problems: low liquid thermal conductivity and high corrosiveness.

There are many candidate fluids in the intermediate temperature range. While some of the fluids have sufficient physical property data to allow their use, none of the fluids has adequate life test data at appropriate conditions.

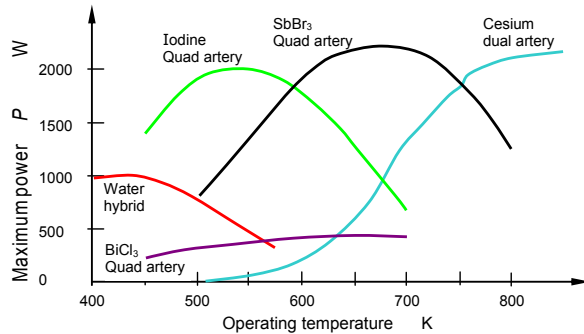

Figure 6.28. Theoretical heat pipe powers for different fluids. Heat pipe dimensions: 2.54mm diameter, 220mm length.

**Evaporator cooling**

Heat removal at the heat pipe remote evaporator can be affected with conventional aluminium finned heatsinks, with fan assistance if necessary. Any alternative cooling method in this chapter may be applicable.

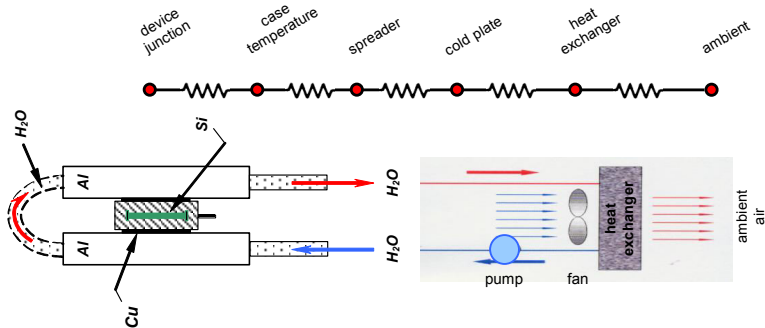

Figure 6.29. Improved cooling with compact indirect cold-plate spreader water-cooling.

**6.8.2 Cold plates – indirect cooling**

Liquid-cooled cold plates perform a function analogous to air-cooled heat sinks by providing an effective means to transfer heat from a component to a liquid coolant. Unlike heat pipes, they are active devices in that liquid is usually forced through them by the action of a mechanical fluid pump. Vacuum-brazed fin-stock cold-plates and copper-based superalloy structures are used and a liquid-cooled microchannel heat sink can remove  $790W/cm^2$  with a temperature increase of  $71^\circ C$  for a 600ml/min flow rate with a pressure drop of 207kPa.

Liquid cooling can reduce effective thermal resistance to as low as 0.01K/W and may provide a much more compact clamp cold-plate spreader heat-sink arrangement, as shown in figure 6.29. Equipment compact form factors require efficient yet cost-effective modes of removing excess heat.

Liquid cooling via cold-plate technology combines a high capacity for heat rejection with an ability to move heat remote from the power electronics to the ambient room air or facility water.

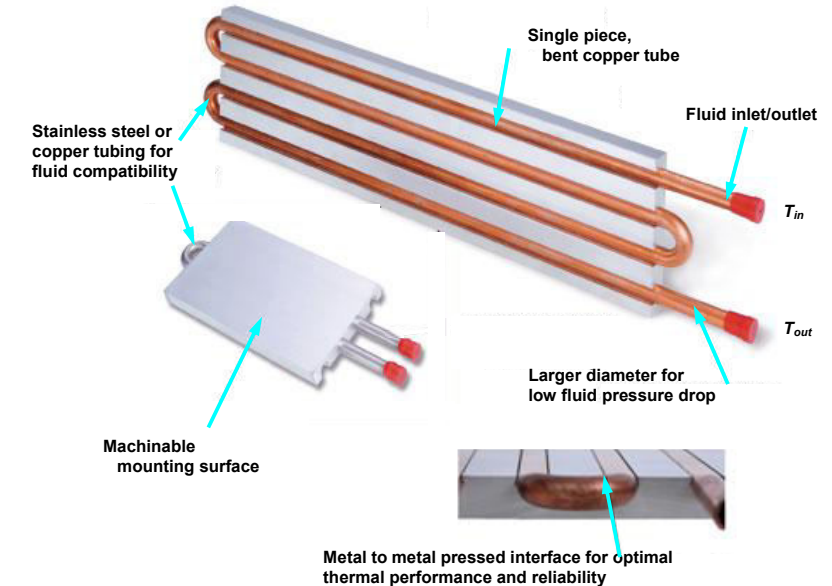

Figure 6.30. Compact indirect cold-plate spreader water-cooler.

Cold plates are used in closed systems where pumped coolants continuously cycle, conveying excess heat away from the devices being cooled. This heat is then dumped into the ambient air via a radiator heat exchanger or recirculating chiller, or to facility water via a liquid-to-liquid heat exchanger or liquid-cooled recirculating chiller, as shown in figure 6.29.

Depending on the specific cold-plate design, the components may be mounted on one or both sides of the plate, which is usually aluminium, as shown in figure 6.30.

In transferring the conducted (dissipated) heat  $P_D$  to the coolant, a cold plate in steady-state must satisfy

$$Q_{flow} = P_D$$

$$[\rho G(T_{out} - T_{in})] = mc_p(T_{out} - T_{in}) = P_D = hA(T_s - T_m)$$

where  $T_m = \frac{1}{2}(T_{out} + T_{in})$

The heat transfer coefficient, from the heated surface, area  $A$ , at temperature  $T_s$ , is

$$h = \frac{\Delta T}{P_D} = \frac{Nu \times k}{D_f} \tag{6.27}$$

where the Nusselt number is  $Nu = 4.44$  for fully developed flow conditions.

$$\begin{aligned} \text{pressure drop: } \Delta P &= \frac{1}{2} \frac{f L \rho V^2}{D_H} & (\text{Pa}) \\ \text{pump power: } P_w &= \Delta P \times G & (\text{W}) \\ \text{heat exchanger length: } L &= \frac{m_f c_p \ell n \Delta T_{out}}{\pi h D_H \Delta T_{in}} & (\text{m}) \\ \text{outlet temperature: } T_{out} &= T_s - (T_s - T_{in}) e^{-\frac{1}{m_f c_p R_c}} & (\text{K}) \end{aligned} \quad (6.28)$$

where  $L$  = length of the cold plate  
 $m_f$  = mass flow rate  
 $f$  = friction factor  
 $c_p$  = specific heat,  $\rho$  = fluid density  
 $D_H$  = diameter (hydraulic)  
 $R_c$  = thermal resistance of one channel  
 $G$  = volumetric flow rate,  $\text{m}^3/\text{s}$

See section 6.10 on microchannels.

A number of cold plate technologies are available. Generally, the cold plate's cost increases with improving performance. The technologies to follow are listed in order of what is typically increasing cold plate efficiency and cost.

- **Tubed cold plates**

Tubed cold plates are the most common designs, giving dependable high performance at a comparatively low cost. A typical device is a flat metal plate, 15 to 30 mm long, with a series of channels on one or both sides. Into these channels is secured a length of serpentine metal tubing through which the liquid coolant flows. Fittings at the inlet and outlet of the coolant tubing connect to the user's coolant source.

Usually aluminium, a tubed cold plate may either be cut to size (with channels for coolant tubing later machined into it), or extruded to size (with the channels formed at the same time the plate is extruded). Some manufacturers use a channel geometry that holds the coolant tubing in place, ensuring good metal-to-metal contact and optimizing thermal transfer. Others secure the tubing to the channels with a performance-limiting thermal epoxy.

Tubing material is predominantly either 5 mm or 10 mm out-side diameter copper or stainless steel. The larger diameter offers a lower pressure-drop. Smaller tubing increases fluid turbulence and can be formed into tighter radii for tighter tube packing and more-compact lower-profile cold plates. If the coolant is tap water, copper will suffice. If the coolant is deionised water or another corrosive fluid, stainless steel is preferable because it is non-reactive.

- **Gun-drilled cold plates**

A gun-drilled cold plate is usually fabricated by drilling a series of holes through the length of an aluminium plate, inserting copper or stainless-steel tubing, and then expanding the tubing to ensure a secure metal-to-metal contact with efficient thermal transfer properties. If aluminium corrosion is not a risk, it is possible to flow coolant with an ethylene glycol additive directly through the gun-drilled holes without inserting the tubing.

For the return fluid path, the holes are drilled perpendicular to the main fluid path and then partially plugged to create a continuous coolant path. Before the development of two-sided tubed cold plates, gun drilling was the preferred approach for two-sided applications. Tubed cold plates are preferred because the inserted copper tubing eliminates the concern of aluminium corrosion. One additional benefit of gun-drilled cold plates is that they can have tighter tolerances than tubed cold plates, specifically in meeting flatness requirements.

- **Vacuum-brazed inner finned cold plates**

Vacuum-brazed aluminium cold plates are reserved predominantly for high-performance custom designs that provide low thermal resistance, and superior leak-free reliability. They afford the greatest flexibility in specifying thermal resistance, thermal flow, pressure drop, fluid path, size, shape, material hardness, surface geometry, and dual-sided component mounting.

To build these cold plates, high-performance corrugated aluminium-fin material is brazed into the liquid cavity below the mounting surface, which is also made of aluminium. The internal fins add heat transfer surface area and create turbulence in the coolant to minimize the fluid boundary layer and reduce thermal resistance.

Depending on requirements, these cold plates can be surface machined to optimize heat-load and/or cold-plate contact. The size range of vacuum-brazed cold plates is from about  $20 \text{ cm}^2$  to about  $4000 \text{ cm}^2$ .

- **Extruded cold plates**

Extruded cold plates represent the highest performance designs with the best thermal performance characteristics. A dimensionally compact structure (typically 5 cm wide x 4 mm. thick), this design features an aluminium or copper extrusion with many internal, discrete, parallel microchannels.

The open ends of the extrusion are welded to connector tubes. The microchannel design provides a large internal surface area and a thin mounting surface that minimizes thermal resistance (see section 6.10).

The channels create turbulence, which minimizes the fluid boundary layer and reduces thermal resistance. This approach also yields excellent thermal uniformity because coolant flows below the entire cold-plate surface. Depending on the direction the header manifolds are mounted, the extruded cold plates may have a 'U' or 'Z' fluid inlet/outlet configuration. Multiple extruded cold plates can be assembled into a single unit or pressed into an aluminium plate.

### Cold-plate performance comparison

Cold-plate performance is normally expressed as thermal resistance, in  $^\circ\text{C}/\text{W}$ . The lower the thermal resistance, the better the cold plate performance and the cooler the surface. Figure 6.31 compares normalized results with respect to area, allowing the various cold-plate technologies to be compared independent of individual part geometries.

Fluid pressure drop increases exponentially with fluid flow rate and viscosity.

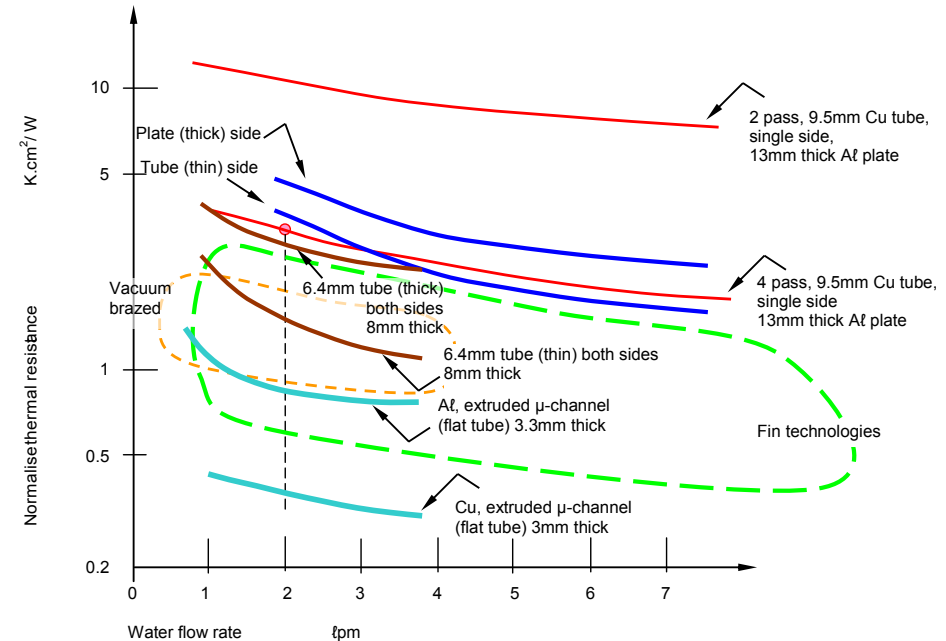

Fig. 6.31. Performance comparison of various types of cold plates.

### Heat transfer fluids for cold plate liquid cooling

One of the most important factors when choosing a liquid cooling technology for an application is the compatibility of the heat transfer fluid with the wetted surfaces of the cooling components or system and the application. Heat transfer fluid compatibility is critical in ensuring long-term system reliability. Some other requirements for a heat transfer fluid may include high thermal conductivity and specific heat, low viscosity, low freezing point, high flash point, low corrosivity, low toxicity, and thermal stability. Based on these criteria, the most commonly used coolants for indirect liquid cooling applications are:

- water
- deionised water
- inhibited glycol and water solutions
- dielectric fluids

By selecting a compatible pairing of heat transfer fluid and wetted materials, the risk of corrosion as well as the thermal performance are optimised. Copper is compatible with water and glycol/water solutions and aluminium is compatible with glycol/water solutions, dielectric fluids, and oils. When using deionised water

or other corrosive fluids, however, stainless steel is used since it is more corrosion resistant than other metals. (See Tables 6.10 and 6.14.) Most cooling systems are compatible with water or glycol/water solutions but require special plumbing for compatibility with deionised water or a dielectric fluid such as polyalphaolefin, PAO.

**Table 6.14: Cold plate metals and compatible fluids**

Materials and Transfer Fluid Compatibility	Water	Glycols EGW	Deionised Water	Oil	Dielectric Fluids (Fluorinert)	Polyalphaolefin, (PAO)
Copper and Copper-Nickel tubing	X	X				
Stainless steel tubing	X	X	X			
Aluminium flat tube or plate fin		X		X	X	X
Copper flat tubing, copper etched or copper brazed	X	X		X	X	X
Nickel brazed			X			

### Selecting a cold plate

To determine the maximum allowable thermal resistance of the cold plate hence to specify a cold plate, it is necessary to know the cooling fluid flow rate, the fluid inlet temperature, the heat load of the devices attached to the cold plate, and the maximum desired cold plate surface temperature,  $T_{max}$ . First, calculate the maximum temperature of the fluid when it leaves the cold plate,  $T_{out}$ . This is important because if  $T_{out}$  is greater than  $T_{max}$ , there is no solution to the problem.

$$T_{out} = T_{in} + \frac{P_d}{m \times c_p} = T_{in} + \frac{P_d}{\rho_f G \times c_p} \quad (6.29)$$

where  $T_{out}$  = temperature of fluid leaving cold plate, K  
 $T_{in}$  = inlet temperature of fluid, K  
 $P_d$  = heat load of power devices, W  
 $\rho_f$  = density of the fluid, kg/m<sup>3</sup>  
 $G$  = cooling fluid flow rate, m<sup>3</sup>/s  
 $c_p$  = specific heat of the cooling fluid, J/kgK

Alternatively, heat capacity graphs describe the change in temperature,  $\Delta T$ , that occurs along the fluid path. To find  $T_{out}$ , add  $\Delta T$  to the inlet temperature,  $T_{in}$ . Assuming  $T_{out}$  is less than  $T_{max}$ , the next step is to determine the required normalized thermal resistance  $R_{\theta}$  for the cold plate using:

$$R_{\theta} = (T_{max} - T_{out}) \frac{A}{P_d} \quad (6.30)$$

where  $R_{\theta}$  = thermal resistance, K/W per unit area  
 $T_{max}$  = maximum desired cold plate surface temperature, K  
 $A$  = area being cooled, m<sup>2</sup>

Any cold plate technology that provides a normalized thermal resistance less than or equal to the calculated value will be a suitable solution.

The graph in figure 6.31 compares normalized thermal resistance expressed in °C.cm<sup>2</sup>/W of cold plate technologies. Normalization of the data allows thermal performance comparison across technologies without regard to physical size. Technologies with lower thermal resistance values offer the highest performance in the application.

### Example 6.5: Cold plate design

A cold plate is used to cool a 5cm x 10cm copper base IGBT that generates 500W of heat. It is cooled with 20°C water at a 2 tpm flow rate. The surface of the cold plate must not exceed 55°C. Calculate the plate outlet header temperature, thence necessary plate thermal resistance. Use  $c_p = 4,184$  J/kgK and  $\rho_f = 998$  kg/m<sup>3</sup>

#### Solution

Given:  $T_{in}$ : 20°C,  $T_{max}$ : 55°C, P: 500 W, Area: 5x10=50 cm<sup>2</sup>

First calculate  $T_{out}$ . Using the heat capacity equation (6.29), the temperature change for 500W at a 2 tpm flow rate is less than 4°C. That is

$$T_{out} = T_{in} + \frac{P}{\rho V \times c_p} = 20^\circ\text{C} + \frac{500\text{W}}{998\text{kg/m}^3 \times \frac{2}{60} \ell/\text{s} \times 10^{-3} \text{m}^3/\ell \times 4,184\text{J/kgK}} = 20^\circ\text{C} + 3.6^\circ\text{C} = 23.6^\circ\text{C}$$

$T_{out}$  is less than  $T_{max}$  so the required thermal resistance is determined by equation (6.30):

$$R_{\theta} = (T_{max} - T_{out}) \frac{A}{P} = (55^\circ\text{C} - 23.6^\circ\text{C}) \times \frac{50\text{cm}^2}{500\text{W}} = 3.14^\circ\text{C.cm}^2/\text{W} \text{ at } 2 \text{ tpm}$$

This point is plotted on the normalized thermal resistance graph in figure 6.31 where any technology below this point will meet the thermal requirement. But because the cooling fluid is water, aluminium tube or plate fin, or nickel-brazed technologies should not be employed.

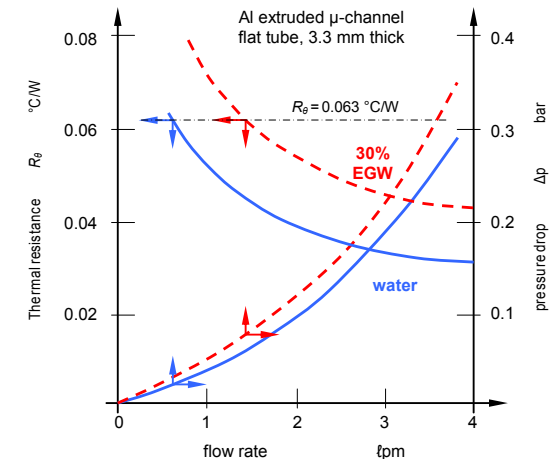

Figure 6.32. Effects of flow rate and coolant variation on thermal resistance.

In example 6.5 the cold plate thermal resistance requirement is  $3.14 \text{ Kcm}^2/\text{W} / 50\text{cm}^2 = 0.063\text{K/W}$ . This requirement can be met by an aluminium  $\mu$ -channel cold plate with the characteristics shown in figure 6.32. This cold plate readily fulfils the thermal resistance requirements with de-ionised water. The aggressive nature of deionised water can be avoided by the using 30% ethylene glycol - water but at the expense of a decreased thermal conductivity, as seen in Table 6.10. From figure 6.32, the necessary flow rate is 1.5 tpm, with a cold plate input to output fluid pressure drop of 0.08 bar. (0.6 tpm and 0.024 bar if de-ionised water could be used).

## 6.9 Direct liquid cooling

### 6.9.1 Immersion cooling – direct cooling

Direct liquid or immersion cooling is a well-established method for accommodating high heat flux. With natural convection two-phase flow, generally termed nucleate pool boiling, the critical heat flux using FC-72 is in the range of 5 to 20W/cm<sup>2</sup>. However, much higher heat fluxes up to 100W/cm<sup>2</sup> can be accommodated with surface enhancement of the heat source. With a device submerged in a pool of dielectric liquid (electrical non-conducting), the heat dissipated in the device produces vapour bubbles that are driven by buoyancy forces into the upper region of the container, where the vapour condenses and drips back into the liquid pool. A disadvantage of this technique is the need for a liquid compatible with the device. Often, water cannot be used because of its chemical and electrical characteristics.



Direct liquid cooling may also be termed direct liquid immersion cooling, since there are no physical walls separating devices and its substrate surface from the liquid coolant. This form of cooling offers the opportunity to remove heat directly from the package with no intervening thermal conduction resistance, other than that between the device heat sources and the package surfaces in contact with the liquid. Direct liquid immersion cooling offers a high heat transfer coefficient which reduces the temperature rise of the package surface above the liquid coolant temperature. As shown in Figure 6.33, the relative magnitude of a heat transfer coefficient is affected by both the coolant and the mode of convective heat transfer (that is, natural convection, forced convection, or boiling). Water is the most effective coolant and the boiling mode offers the highest heat transfer coefficient. Direct liquid immersion cooling also offers greater uniformity of package temperatures than is provided by air-cooling.

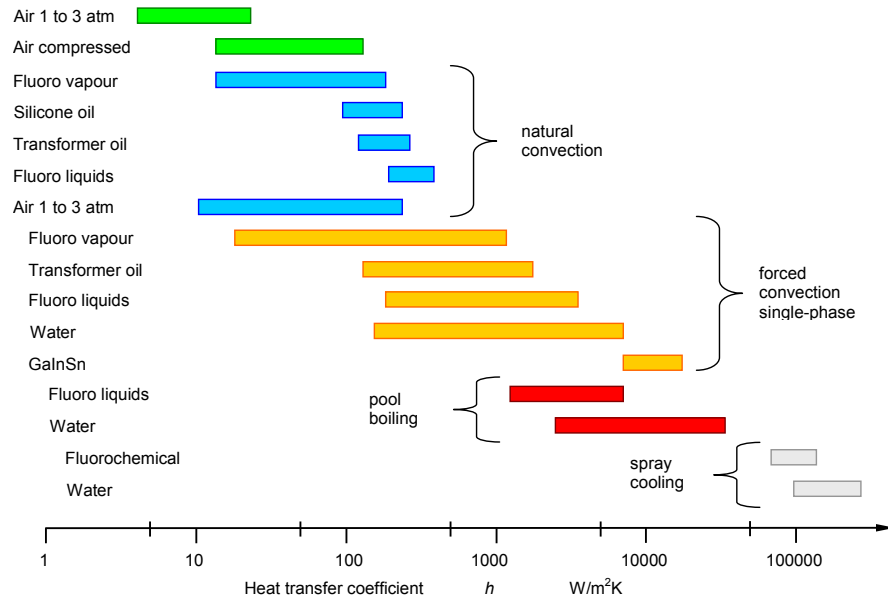

Figure 6.33. Relative magnitude of heat transfer coefficients for various coolants and modes of convection. (see figure 6.1)

### Coolant considerations

**Immersion cooling** involves more than just the selection of a direct immersion liquid based on heat transfer characteristics alone. Chemical compatibility of the coolant with the mounting and packaging materials exposed to the liquid are the primary consideration. There may be several coolants which can provide adequate cooling, but a limited few will be chemically compatible. Water is an example of a liquid which has desirable heat transfer characteristics, high thermal conductivity for example, but is generally unsuitable for direct immersion cooling because of other chemical characteristics, such as dielectric constant. The fluorocarbon liquids listed in Table 6.15 are generally considered the most suitable liquids for direct immersion cooling, despite their poorer thermo-physical properties.

As shown in Table 6.15, the thermal conductivity, specific heat, and heat of vaporization of fluorocarbon coolants are lower than water. These coolants are clear, colourless per-fluorinated liquids with a relatively high density and low viscosity. They also exhibit a high dielectric strength and a high volume resistivity. The liquid therefore serves to both cool and insulate the components. The boiling points for available 'fluorinert' liquids range from 30°C to 253°C.

All high power and high voltage power electronics can be immersed in the fluorinert. As a component heats up, the fluorinert in contact with it vaporizes and it is this liquid to vapour phase transition which effectively removes the excess heat from the components (heat of vaporization). The fluorinert vapour is cooled by a heat exchanger located in the area above the fluid. This cooling technique allows high-power electronics to operate continuously and reliably in a small volume.

Why use a dielectric liquid, specifically FC-72 instead of water?

- Same weight of water will extract more than three times the heat for the same temperature rise (higher specific heat).
- Water is eleven times more conductive.
- Same weight of water upon evaporating will extract 27 times more heat (higher heat of vaporization).
- However, FC-72 has a dielectric constant that is 2% that of water, that is, much less unwanted dielectric current will flow.

Table 6.15: Comparison of thermo-physical properties of some fluorocarbon coolants and water

Property		units	FC-87	FC-72	FC-77	H <sub>2</sub> O
Boiling Point		@ 1 Atm, °C	30	56	97	100
Density	$\rho_f$	$\times 10^3$ kg/m <sup>3</sup>	1.633	1.680	1.780	0.997
Specific Heat		$\times 10^3$ W.s/kg.K	1.088	1.088	1.172	4.179
Thermal Conductivity	$\lambda$	W/m.K	0.0551	0.0545	0.057	0.613
Dynamic Viscosity	$\nu$	$\times 10^{-4}$ kg/m.s	4.20	4.50	4.50	8.55
Heat of Vaporization	$L$	$\times 10^4$ W.s/kg	8.79	8.79	8.37	243.8
Surface Tension		$\times 10^{-3}$ N/m	8.90	8.50	8.00	58.9
Thermal Coefficient of Expansion		$\times 10^{-3}$ K <sup>-1</sup>	1.60	1.60	1.40	0.20
Dielectric Constant		=1 for a vacuum	1.71	1.72	1.75	78.0

These liquids should not be confused with the 'Freon' coolants which are chlorofluorocarbons (CFCs). Although some of the 'Freons' exhibit similar cooling characteristics, concern over their environmental effect preclude their use.

### Modes of heat transfer

The convective heat transfer processes upon which liquid immersion cooling depends may be classified as natural convection, forced convection, or boiling modes. The relative magnitude of heat fluxes which can be accommodated by each mode is shown in Figure 6.34, as a function of 'wall superheat' or surface-to-liquid temperature difference for a typical fluorocarbon coolant.

**Natural convection:** As in the case of air-cooling, natural convection is a heat transfer process in which mixing and fluid motion is induced by coolant density differences caused by the heat transferred to the coolant. As depicted in Figure 6.34, this mode of heat transfer offers the lowest heat flux or cooling capability for a given 'wall superheat'. Nonetheless, the heat transfer rates attainable with liquid natural convection can exceed those attainable with forced convection of air. Natural convection would typically be employed within a closed container to transfer heat from die or modules to liquid, and then from the liquid to the walls of the container. Heat could then be transferred from the walls to outside air ambient by natural or forced convection.

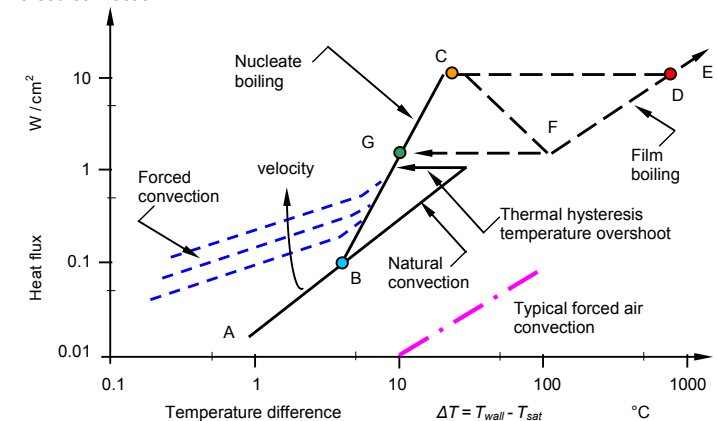

Figure 6.34: Typical heat transfer regimes for immersion cooling with a fluorocarbon liquid.



**Forced convection:** Higher heat transfer rates may be attained by utilizing a pump to provide forced circulation of the liquid coolant over the die or module surfaces. This process is termed forced convection; and as with air-cooling, the allowable heat flux for a given surface-to-liquid temperature difference can be increased by increasing the velocity of the liquid over the heated surface. Depending upon the surface geometry and the nature of the flow (that is, laminar or turbulent), the heat transfer coefficient will be proportional to the velocity to a power between 0.5 and 0.8. The penalty for increasing cooling performance in this way, is a higher-pressure drop. This can mean a larger pump and higher system operating pressures. Although forced convection requires the use of a pump and the associated piping, it allows removal of heat from high power modules in a confined space; and then transports the heat via the liquid coolant to a remote heat exchanger to reject the heat to air or water.

**Boiling:** Boiling is a complex convective heat transfer process depending upon liquid-to-vapour phase change with the formation of vapour bubbles at the heated surface. It is commonly characterized as either *pool boiling* (occurring in a stagnant liquid) or *flow boiling*. The pool boiling heat transfer rate  $Q$  usually follows a relationship of the form

$$Q = C_{gr} \times A \times (T_{wall} - T_{sat})^n \quad (6.31)$$

where  $C_{gr}$  is a constant depending on each fluid-surface combination,  
 $A$  is the heat transfer surface area,  
 $T_{wall}$  is the temperature of the heated surface,  
 $T_{sat}$  is the saturation temperature (that is, boiling point) of the liquid, and  
 $n$  is an exponent, typically about 3.

The boiling curve for a particular surface and fluid of interest (for example, silicon and FC-72) is usually obtained experimentally. An example of a boiling curve depicting the cooling path from natural convection to film boiling is shown in Figure 6.34. If die power is gradually increased in small steps, cooling occurs first by natural convection (A - B). Eventually a power level is reached at which sufficient superheat is available to initiate the growth of vapour bubbles on the surface and boiling starts (B). As power is increased, more nucleation sites become active and the frequency of bubble departure increases. The region between B and C is termed the nucleate boiling regime. Vigorous agitation of the hot boundary along the heated surface, and gross fluid circulation caused by the motion of the vapour bubbles, provide the ability to accommodate substantial increases in heat flux with minimal increases in surface temperature. As power is increased to point C, the critical heat flux condition is reached. So many bubbles are generated at this point that they begin to form a vapour blanket inhibiting fresh liquid from reaching the surface. Further increases in power will result in a transition to film boiling (D - E). In this regime, heat transfer from the surface to the liquid is dependent on thermal conduction through the vapour, which is poor. In most power electronic cooling applications, transition to film boiling will result in failure due to high junction temperatures. To take advantage of boiling to cool electronic devices, it is desirable to operate in the nucleate boiling regime (B - C).

A problem often associated with pool boiling of fluorocarbon liquids is that of temperature overshoot. This behaviour is characterized by a delay in the inception of nucleate boiling (that is, beyond point B), such that the heated surface continues to be cooled by natural convection; with increased surface temperatures unless a sufficient superheat is reached for boiling to occur. This behaviour is a result of the good wetting characteristics of the fluorocarbon liquids and the smooth nature of silicon die and their metallisation. There is minimal temperature overshoot associated with flow boiling cooling applications.

The typical critical heat fluxes encountered in saturated (that is, liquid temperature saturation temperature) pool boiling of fluorocarbon liquids range from about 10 to 15 W/cm<sup>2</sup>, depending upon the nature of the surface (that is, material, finish, geometry). The allowable critical heat flux may be extended by subcooling the liquid below its saturation temperature. For example, the critical heat flux can be increased to as much as 25 W/cm<sup>2</sup> by reducing the liquid temperature to -25°C.

Higher critical heat fluxes may be achieved using flow boiling. For example, heat fluxes from 25 to over 30 W/cm<sup>2</sup> have been reported for liquid velocities of 0.5 to 2.5 m/s over the heated surface. Heat fluxes in excess of 100 W/cm<sup>2</sup> have been obtained with a FC-72 liquid jet impinging upon a 6.5 mm x 6.5 mm chip at a flow rate of 2.2 cm<sup>3</sup>/s.

#### Other considerations

Since fluorocarbon liquids are expensive, they should only be used in closed systems. Whether the application is in a self-contained module or a forced flow scheme, the seal materials must be compatible with the liquid. If boiling is to take place, then the design must incorporate a means to condense the resulting vapours. A finned surface may be designed for this purpose, or a remote finned condenser surface cooled by air or water might be used. In flow systems, care must be taken in selecting a pump. The relatively high vapour pressure of the low boiling point fluorocarbons generally require that a higher suction head be provided to prevent cavitation in the pump. In forced circulating liquid systems, it may be desirable to add a particulate and a chemical filter to ensure the long-term purity of the coolant.

#### 6.9.2 Liquid jet impingement – direct cooling

Jet impingement cooling, as shown in figure 6.35, is similar to spray cooling but is performed with a lower nozzle pressure drop and a higher fluid flow rate. This lower pressure requirement, in conjunction with a high flow volume, reduces nozzle clogging and reduces noise levels. Cooling of 90W/cm<sup>2</sup> with a 100°C temperature rise using a flow rate of only 8ml/min is possible. A closed loop impingement jet gives cooling of 180W/cm<sup>2</sup> using water and a flow of 0.3 l/min at 300kPa. The micropump used 7W to drive the fluid flow.

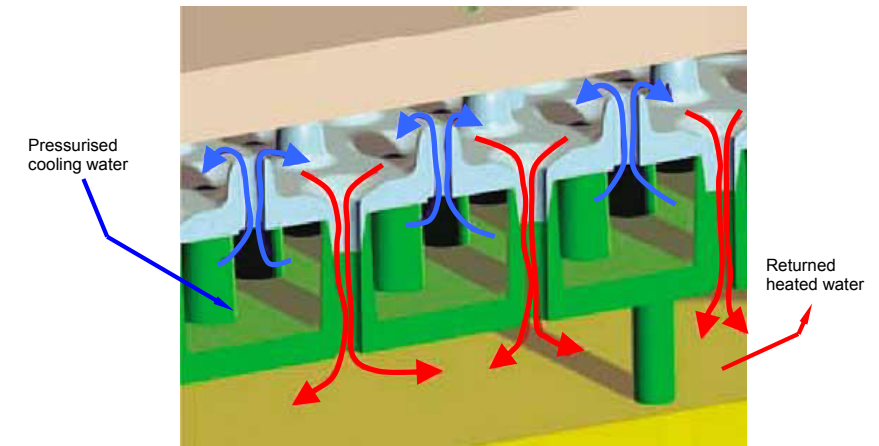

Figure 6.35. Available multiple jet impingement liquid cooling.

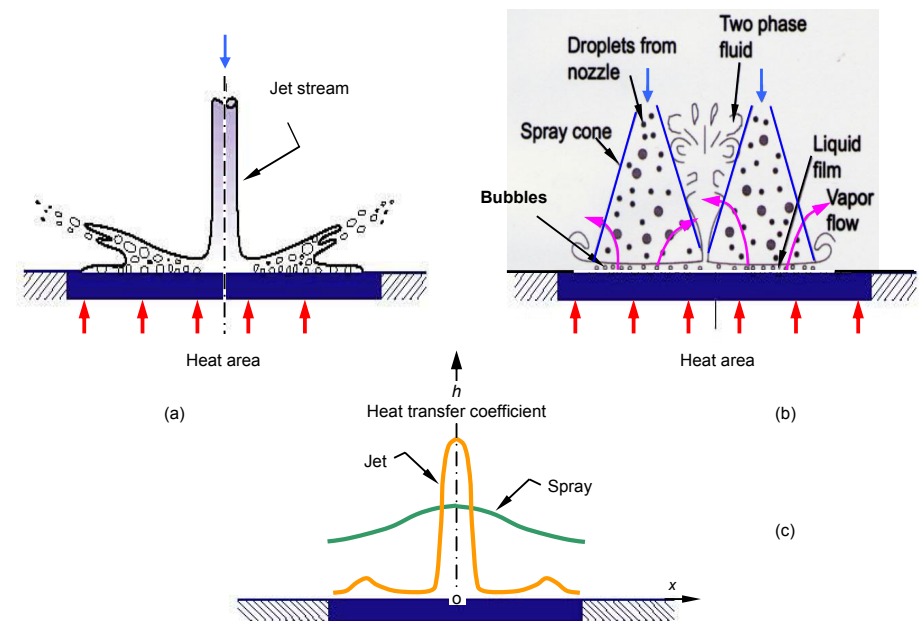

Figure 6.36. Illustration of: (a) spray cooling; (b) jet impingement cooling; and (c) resultant heat transfer coefficient,  $h$ .

6.9.3 Spray Cooling – direct cooling

Spray cooling breaks up the liquid into fine droplets that impinge individually on the heated wall surface. Cooling of the surface is achieved through a combination of thermal conduction through the liquid in contact with the surface and evaporation at the liquid-vapour interface (latent heat of vaporization). The droplet impingement both enhances the spatial uniformity of heat removal and delays the liquid separation on the wall during vigorous boiling. The hot vapour is recovered by removing the waste heat to the ambient in a heat exchanger where the vapour condenses back to a liquid. The fluid is continually recycled within a closed system. Using vapour for heat transport eliminates all resistance between the heat source and the ultimate heat destination.

Spray cooling technology enables all surfaces exposed to the liquid-vapour environment to remain close to the saturation temperature of the fluid. The result is an isothermal environment around the power devices which effectively reduces hot spots and thermal cycling – the primary cause of power device failure. Spraying reduces the flow rate requirements but requires a high nozzle pressure drop than jet impingement. Spray pattern types include an array of swirling turbulent hollow-cone sprays, with a wide range of droplet sizes. Drawbacks include likelihood of nozzle clogging, repeatability of impact patterns, high sensitivity to nozzle to surface distance, and the need for filters and pumps.

Spray cooling and jet impingement (as shown in Figure 6.36) are often considered competing options for electronic cooling. Spray evaporative cooling with a Fluorinert coolant can maintain junction temperatures between 70°C and 85°C for heat fluxes from 15 to 55 W/cm<sup>2</sup>. Spray cooling improves thermal management, increases system-packaging density, and reduces weight. Die-level spray cooling allows a maximum heat flux of over 160 W/cm<sup>2</sup>.

6.10 Microchannels and minichannels

The concept of microchannels applied to the thermal management of high heat-flux power electronics is simple. Because heat-transfer coefficients generally increase with decreasing size, the passage size (microchannels) should be made as small as possible. This results in a dense package with higher heat transfer and a larger surface area-to-volume ratio than a conventional cooling device.

The term 'micro' is applied to devices having hydraulic diameters of ten to several hundred micro-metres, while 'mini' refers to diameters of the order of one to a few millimetres. A low flow rate within micro-channels produces laminar flow resulting in a heat transfer coefficient inversely proportional to the hydraulic diameter. In other words, the smaller the channel, the higher the heat transfer coefficient. Unfortunately, the pressure drop increases with the inverse squared of the channel width, whilst maintaining the mass flow constant. Stacking of microchannel layers is used to decrease the pressure drop, but flow non-uniformity across the channel remains a problem, producing non-uniform cooling.

A 50µm wide, 300µm deep, 1cm long microchannel passage, experiences a 30-psi drop with a 0.66 lpm water flow, and can dissipate 790 W/cm<sup>2</sup> with a 71°C temperature rise. With 5 to 100µm channel sizes, the heat transfer coefficient can reach 80kW/m<sup>2</sup>K.

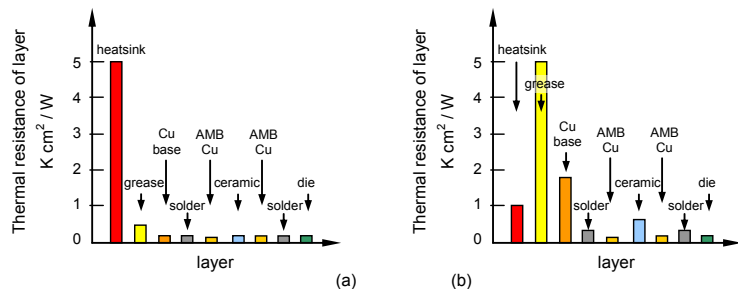

Figure 6.37. Thermal resistivities of a typical power module with: (a) a conventional heatsink and (b) a microchannel heatsink, indicate that layers other than the heatsink can dominate the performance of microchannel designs.

Integrated microchannel heatsink

Figure 6.37 displays the fractions of the thermal resistivity attributed to different individual layers for a typical power module. In the case of microchannel cooling, the largest contributor to the thermal resistivity is the thermal grease layer between the base-plate and the heatsink. Because of the increased importance of the conductive resistance of the stack, a better solution would be to eliminate some of the layers from the structure. An integrated heatsink with a series of microchannels

fabricated directly into the bottom copper layer of the active metal braze (AMB) substrate is shown schematically in figure 6.38, and has advantages in reducing both the convective and conductive resistances of the module.

By using substrate level microchannels, the convective thermal resistivity is reduced dramatically. In addition, this stack removes the base-plate solder, the copper base-plate and, most importantly, the thermal grease from the conductive path. As seen in figure 6.37, this results in the elimination of the two largest resistances in the structure. A thermal grease or epoxy layer for attachment, is a thin 75µm layer with a relatively high thermal conductivity of 9 W/m/K. The overall result is a reduction of the total stack resistivity by a factor of two when compared to a microchannel heatsink.

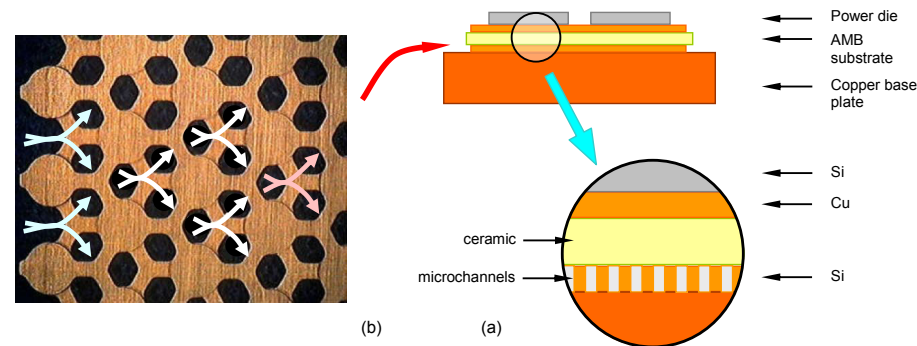

Figure 6.38. Integrated microchannel heatsink design, where microchannels are: (a) fabricated directly into the bottom copper layer of the AMB substrate or (b) created between at least two thin (0.3mm) copper etched mesh layers, bonded by a melting process.

Analytical optimization

First-order heat transfer is governed by the thermal resistivity  $R_\theta$ , which is defined as the temperature rise divided by the heat flux. For convective heat transfer in channels having hydraulic diameter  $D_H$ , the thermal resistivity is calculated as:

$$R_\theta = \frac{\Delta T}{P_d} = \frac{D_H}{k \times Nu} \tag{6.32}$$

where  $k$  is the working fluid thermal conductivity and  $Nu$  is the Nusselt number for the appropriate flow condition ( $Nu = A \times Re^m Pr^n$ ).

$$Nu = \frac{h \times L}{k}$$

where  $h$  is the convective heat transfer coefficient, W/m<sup>2</sup> K  
 $L$  is the characteristic passage length of the microchannel  
 $Pr$  is the Prandtl number ( $= v \times c_p / k$ )

For example, for laminar, fully developed flow in a circular passage with constant heat flux,  $Nu_{DH} = 4.36$ . [ $Nu_{DH} = 3.66$  for convection with a constant uniform surface temperature.]

In addition, the pressure loss  $\Delta P$  is calculated using the friction factor  $f$  as:

$$\Delta P = \frac{1}{2} \rho v^2 f \frac{L}{D_H} \tag{6.33}$$

with

$$f = \frac{64}{Re}$$

where  $\rho_f$  is the fluid density and  $f$  is the friction factor (loss coefficient), in laminar, fully developed flow in a circular passage

$Re$  is the Reynolds number

$$Re = \frac{\rho_f \times v \times D_H}{\nu} \tag{6.34}$$

where  $v$  is the fluid velocity (volumetric flow rate) and  $\nu$  is the fluid kinematic viscosity.

These basic expressions for  $R_\theta$  and  $\Delta P$  are used to select the optimal channel sizing. The passage dimensions are chosen to minimize the thermal resistivity  $R_\theta$  subject to pumping constraints on maximum pressure loss and flow rate. Typical performance characteristics are as shown in figure 6.32.

The primary variables to be optimized are the channel width and pitch. These values vary beneath a heat source of 2x2 cm size between 10 to 200 cooling passages and a ratio of wall thickness to channel width of 0.1 to 2. These dimensions result in a range of flow conditions, including laminar, turbulent, developing and fully developed regimes. In addition, the channel height in the AMB substrate is varied from 0.05mm to 0.3mm, which is the maximum depth allowed due to the thickness of the bottom copper layer. The typical coolant is water at room temperature. The pump constraints are specified as 4  $\mu\text{m}$  maximum flow rate and 25 psi maximum pressure loss, which are representative values for power electronics cooling applications. The channel width is at least 100 $\mu\text{m}$ , due to the difficulty of manufacturing narrower passages in copper. For the integrated microchannel heatsink, the preferred channel shape has a width of 100 $\mu\text{m}$ , a depth of 300 $\mu\text{m}$  and a wall thickness between channels of 100 $\mu\text{m}$ . The narrow channel width and small pitch results in a high surface area-to-volume ratio, while the tall channel height abates the pressure loss through the passage. The calculated thermal resistivity for this design is 0.042K.cm<sup>2</sup>/W.

The performance is effective and superior to existing heatsinks since no thermal grease layer is needed. The overall thermal resistivity of a power module equipped with this heatsink is less than 0.15K.cm<sup>2</sup>/W, resulting in less than a 75°C junction-to-coolant temperature rise for a heat flux of 500W/cm<sup>2</sup>. This thermal performance is better than any existing heatsink using a comparable material stack.

Microchannel cooling is more effective for areas smaller than 7 x 7 cm. Integrated single and two-phase micro heat sinks are able to cool about 450 W/cm<sup>2</sup> using both single and two-phase heat transfer. For two-phase flow, the pumping power is about ten times lower and the required flow rate is considerably lower. By using off-set strip fins and a split-flow arrangement, cooling of over 300 W/cm<sup>2</sup> at 24 kPa is possible with a flow of 1.5  $\mu\text{m}$ . A silicon microchannel cooler can be used for high-power chips. A separate microchannel cold plate is bonded to the back of the chip. This requires a low interface thermal resistance. If the microcooler is based on silicon, a rigid bonding means that silver-filled epoxies or solder should be used, giving power densities in excess of 400W/cm<sup>2</sup>, for a flow of 1.2  $\mu\text{m}$  at 30kPa.

It is possible to push microchannel heat transfer even further by utilizing boiling. In addition to offering higher heat transfer coefficients, boiling convection in microchannels requires less pumping power than single-phase liquid convection to achieve a given heat sink thermal resistance. For the same heat flux, the pressure drops by a factor of 20. A 1000W/cm<sup>2</sup> cooling system based on boiling heat transfer in microchannel heat sinks using a flow rate of 1/2  $\mu\text{m}$  is possible. Local heat transfer coefficients may change appreciably over time leading to local temperature changes of 10 to 15°C. Also backflow of already heated flow due to expansion of bubbles is observed.

If fluid impinges on the surface to be cooled, performance can reach 1000 W/cm<sup>2</sup>K, 14 to 21kPa and 0.05K/W/cm<sup>2</sup>. Pumped liquid (both single and two-phase) cooling technologies in addition to loop heat pipes for space applications, in a single-phase solution, incorporates an oscillating flow heat transfer mechanism, are capable of cooling over 1300W/cm<sup>2</sup>.

A different way of making microchannels is to use metal foams or metal made porous, which accommodated a heat flux of 500W/cm<sup>2</sup> for a 50K difference at a pressure drop of 115kPa, using water.

### 6.11 Electrohydrodynamic and electrowetting cooling

As an alternative to a continuous flow created either by temperature differences or by mechanical means, liquid can be formed and moved in droplets of nano-to-millilitre size by means of electric fields. Electrowetting on a dielectric film, in which the surface property of a dielectric film can be modified between hydrophobic and hydrophilic states using an electric field, can be used to provide the basis for a direct micropumping system. Electrowetting involves control of the surface tension of a liquid and can cause a droplet of liquid to bead or spread out on the surface depending upon its surface state.

With 0.4 m $\mu\text{m}$  it is theoretically possible to cool 90 W/cm<sup>2</sup>. The application of electrowetting to liquid metals has the advantage, besides a better heat transfer capability, of necessity a much lower voltage, 2V instead of 50V, to produce the electric field.

### 6.12 Liquid metal cooling

Table 6.9 shows properties for various liquid metals, where the viscosity is given at room temperature and water is included for comparison. Advantages of liquid metals are lower thermal expansion coefficient compared to water and freezing introduces fewer problems. Ideally, the metal should be non-poisonous, non-caustic, low viscosity, high thermal conductivity, and high heat capacity.

Pure Bismuth, Bi, melts at 271°C but some of its alloys have considerable lower melting points. Woods metal (Lipowitz's alloy, eutectic alloy 50% Bi, 26.7% Pb, 13.3% Sn, and 10% Cd by weight) is probably the

most well-known, melting at 70°C. By alloying with metals such as lead, tin, cadmium and indium, it is possible to get a lower limit of 47°C. Such alloys have the disadvantage of high melting points.

Pure gallium, Ga, melts at 29.7°C and has a latent heat of 80.1 J/g, but several of its alloys have much lower melting points. Although non-toxic and relatively cheap, the main drawback is its aggressiveness towards most metals. All gallium alloys must therefore be enclosed within ceramic walls, which is difficult to realise. Because its surface tension is much higher than water, liquid Gallium is immune to the presence of small cracks or channels in imperfect seals that would cause leaks if water were the coolant.

**Table 6.16: Approximate thermal properties for liquid metals. Water is included for comparison**

Metal	Melting point °C	Boiling point °C	Density kg/m <sup>3</sup>	Specific heat J/kgK	Conductivity $\lambda$ W/mK	Viscosity $\nu$ Ns/m <sup>2</sup> $\times 10^{-3}$	Kinematic viscosity $\nu$ m <sup>2</sup> /s $\times 10^{-8}$	Prandtl number $c_p \mu / k$
bi-alloys	47-271		9,800	142	8.4			
Ga	29.7	2205	5,900	334	28	2.04	32	0.0261
Hg	-38.8	356.8	13,546	140	7.8	0.15	11.4	0.0278
FC-72		56	1680	1088	0.0545	0.45		
H <sub>2</sub> O	0	100	998	4184	0.613	0.86	85.5	6.62
NaK alloy (22/78%)	-11.1	783.8	892	1058	25.3	0.94	53.8	0.0213

The heat transfer coefficient  $h$  is the rate that thermal energy is removed from a surface per unit surface area per temperature differential, and is related to Nusselt number  $Nu$ , by

$$h = \frac{Nu \times \lambda}{k_D}$$

where  $k_D$  is the characteristics dimension of the geometry and

$\lambda$  is thermal conductivity, shown in tables 6.15 and 6.16.

In a circular tube characterised by convection with a uniform surface temperature and laminar fully developed conditions, Nusselt number is constant,  $Nu = 4.36$ , and 3.66 for a uniform heat flux condition.

Apart from heat pipes based on liquid metals, mainly for the high-temperature range, Ga-Sn-In eutectics that remain liquid down to minus 19°C are possible. The thermal heat transfer coefficient  $h$  is ten times larger than for water. High-performance liquid metal cooling loops use magnetofluidynamic MFD pumps, with over 200 W/cm<sup>2</sup> cooling capacity, using a flow of 0.3  $\mu\text{m}$  at 15 kPa.

Mercury, Hg, has attractive thermal properties and has been used as a working fluid for power generating purposes. It has environmental drawbacks.

The best liquid metal candidate is an eutectic solution of sodium and potassium, NaK. The melting point is as low as -12°C. Its density and viscosity are similar to water but has a lower specific heat and a much higher thermal conductivity. It can be used with nickel, chrome and steel but is aggressive to cadmium, antimony, bismuth, copper, lead, silicon, tin, and magnesium. It also reacts violently with air and water. This alloy is associated with material and handling problems. Liquid sodium has nevertheless been used as a coolant for nuclear reactors, which shows that these drawbacks can be managed.

Any form of liquid cooling is associated with leakage hence reliability problems. Consideration of emersion cooling, etc., should be restricted to applications requiring precise temperature control and heat dissipation rates that are too high for effective removal by conduction and air cooling.

### 6.13 Solid state cooling

#### 6.13.1 Thermoelectric coolers

A thermoelectric module is a highly reliable, small, light, solid-state, active device that can operate as a heat pump or as an electrical power generator. When used to generate electricity, the module is called a thermoelectric generator (TEG). When used as a heat pump, a refrigerator, the module utilizes the Peltier effect to move heat and is called a thermoelectric cooler (TEC).

When current passes through the junction of two different types of conductors, a temperature change results at the junction. However, the practical application of this concept requires semiconductors that are good conductors of electricity but poor conductors of heat. Anisotropic orientated polycrystalline bismuth

telluride is mainly used as the semiconductor material, heavily doped to create either an excess (*n*-type) or a deficient (*p*-type) of electrons, as shown in figure 6.39a. If the current is reversed, the heat is moved in the opposite direction. In other words, what was the hot face will become the cold face and vice-versa.

A thermoelectric device consists of a number of *p* and *n* type pairs (couples) connected electrically in series and sandwiched between two ceramic plates, as shown in figure 6.39. When connected to a DC power source, dc current causes heat to move from one side of the TEC to the other. This creates a hot side and a cold side on the TEC. The device to be cooled is mounted on the cold side of the TEC and the hot side is thermally connected to another TEC or a heatsink which dissipates the heat into the environment. A heat exchanger with forced air or liquid may be required. A thermoelectric cooler does not absorb heat, it only transfers or moves it.

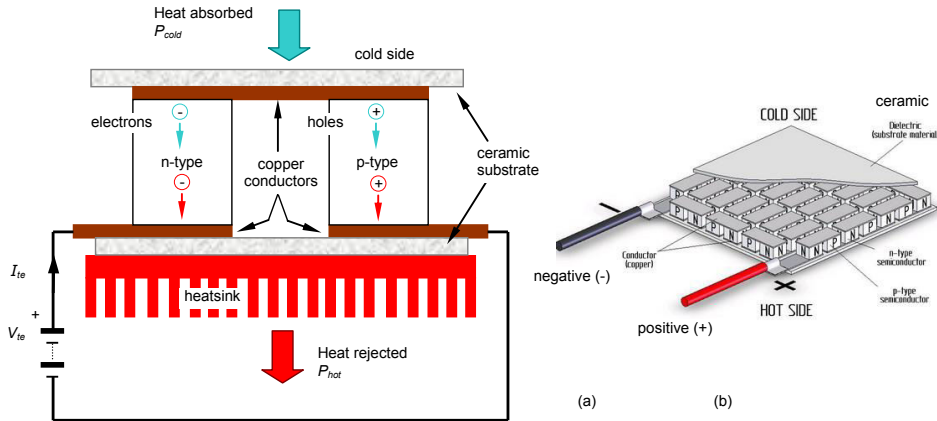

Figure 6.39. The thermoelectric cooler: (a) principle and (b) module.

Design for power electronic cooling involves the initial specification of three parameters, the hot and cold side temperatures,  $T_{hot}$  and  $T_{cold}$ , (or  $T_h$  and  $T_c$ ) hence the temperature gradient or difference  $\Delta T = T_h - T_c$ , ( $\Delta T > 0$ ) and the amount of heat, or the thermal load, in Watts, to be absorbed or removed at the cold surface of the TEC,  $P_{cold}$ .

The cold surface temperature is the desired temperature of the power electronic component to be cooled, directly in contact with the TEC.

The hot surface temperature is defined by two major parameters:

- The temperature of the ambient environment to which the heat is being rejected.
- The efficiency of the heat exchanger that is between the hot surface of the TEC and the ambient.

The thermal load includes the active  $I^2R$  type losses of the device to be cooled, as well as parasitic loads such as conduction through any mechanical object in contact with both the cold surface and any warmer environment, like conduction through mounting bolts and plates (and the radiation from the plates). Figure 6.40 shows the thermal resistance components and system model.

The coefficient of performance, CoP, is useful in selecting a module (the larger CoP the better), and is defined by

$$CoP = \frac{\text{heat absorbed at the cold junction}}{\text{electrical dc input power}} = \frac{P_{cold}}{V_{te} \times I_{te}} = \frac{P_{cold}}{P_{tec}} \quad (6.35)$$

where  $I_{te}$  is the current drawn by the TE module  
 $V_{te}$  is the voltage applied to the TE module

A maximum CoP represents the minimum input dc power  $P_{tec}$ , therefore minimum total heat to be rejected by the heat exchanger on the hot side  $P_{hot}$ , that is  $P_{hot} = P_{cold} + P_e$ . Performance characteristic charts, as in figure 6.41, are usually provided. These allow the terminal dc voltage and dc current requirements to be determined from the temperature difference  $\Delta T$  and heat to be absorbed on the cold side,  $P_{cold}$ . The maximum  $\Delta T$  is about 67°C for a single TEC, higher than this requires cascading (stacking) of TECs. The negative quadratic shape in the lower plot, represents the optimal operating curve. Further TE effect and module technical details can be found in Chapter 28.10.

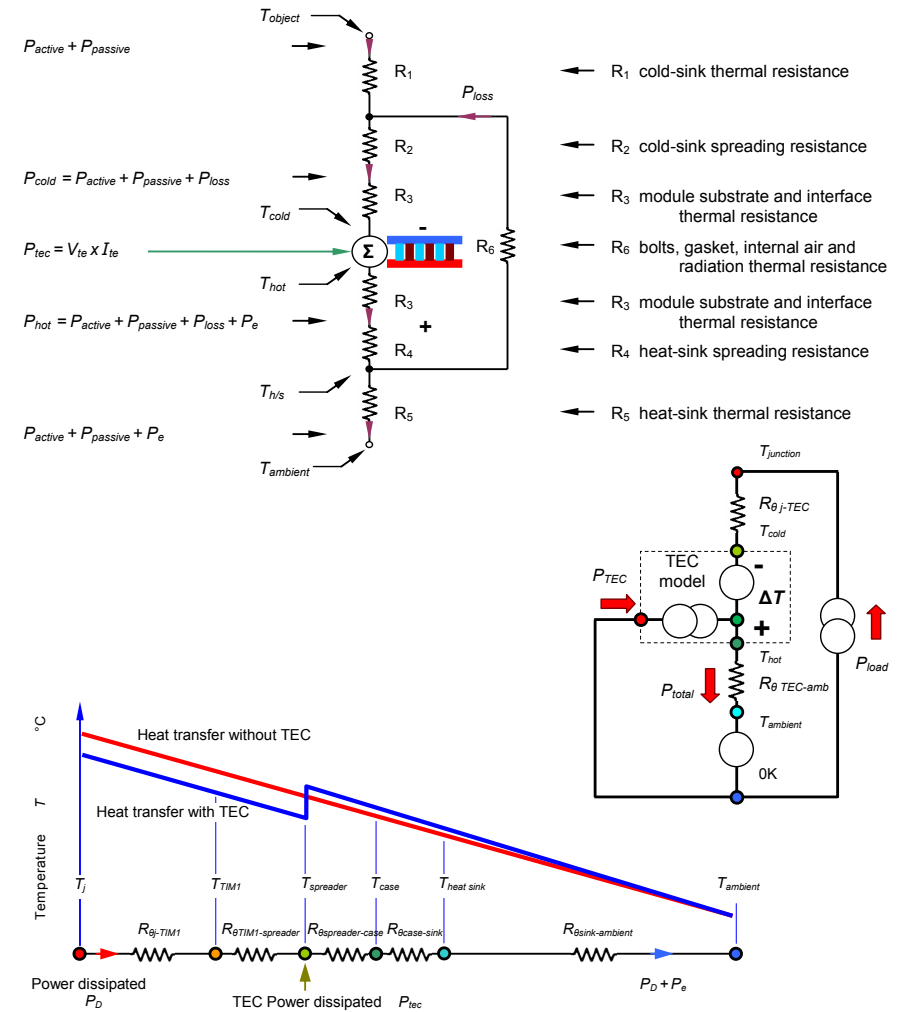

Figure 6.40. The thermal resistance TEC cooling model.

**Example 6.6: Thermoelectric cooler design**

A semiconductor junction dissipating 100W has a steady-state thermal resistance to its case mounting of  $R_{\theta} = 0.15 \text{ K/W}$ . If the TEC cold-side temperature is not to exceed 5°C in a 25°C external ambient, determine the heatsink requirement to dissipate the transferred TEC heat, if the TEC has the characteristics shown in figure 6.41, where  $T_h = 35^\circ\text{C}$ . Assuming  $P_{loss} = 0\text{W}$ , determine:

- the semiconductor junction temperature;
- the coefficient of performance CoP for the TE module; and
- heatsink requirement.

**Solution**

- The junction temperature is  $T_{cold} + \text{Power dissipated} \times R_{\theta-j-c} = 5^\circ\text{C} + 100\text{W} \times 0.15\text{K/W} = 20^\circ\text{C}$ .



ii. The temperature differential across the TE module is

$$\Delta T = T_{hot} - T_{cold} = 35^{\circ}\text{C} - 5^{\circ}\text{C} = 30^{\circ}\text{C}$$

Only one stage (no TEC cascading is required) should be necessary since the maximum  $\Delta T < 62^{\circ}\text{C}$ .

Since thermal leakage losses are assumed zero, the cold-side power losses to be transferred are 100W, which is shown as the horizontal plotted line in the performance graph in figure 6.41.

The vertical intersection of the 100W horizontal line and the  $\Delta T = 30^{\circ}\text{C}$  curve gives the necessary TE module input current 18.2A, and associated terminal voltage, 9.6V, from the upper curve intersection. The TE module electrical input power  $P_e$  is therefore  $9.6\text{V} \times 18.2\text{A} = 74.7\text{W}$

From equation (6.35), the TE module coefficient of performance is

$$CoP = \frac{P_{cold}}{V_{te} \times I_{te}} = \frac{P_{cold}}{P_{tec}} = \frac{100}{74.7} = 1.39$$

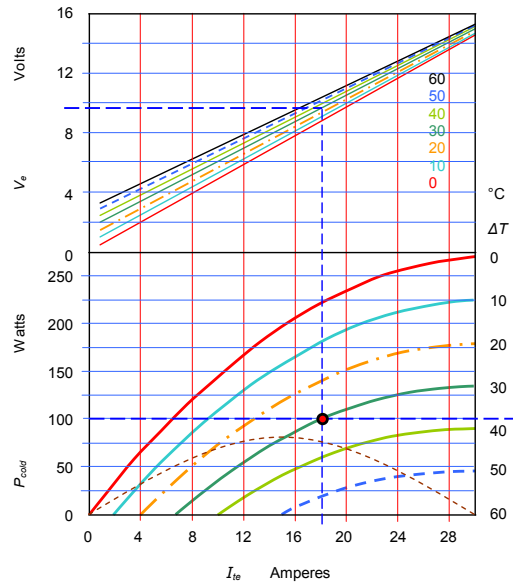
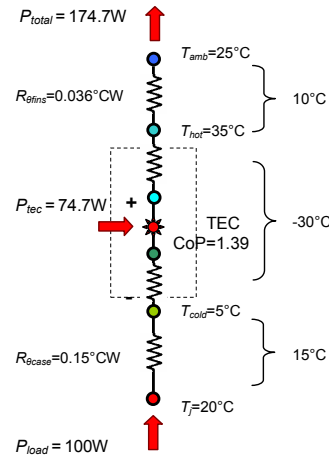

Figure 6.41. Thermoelectric module characteristics,

$P_{max} = 270\text{W}$ , with 127 couples for a  $35^{\circ}\text{C}$  hot-side temperature  $T_{hot}$ ,  $\Delta T = 62^{\circ}\text{C}$ , and  $I_{max} = 30\text{A}$ .



iii. The heatsink thermal resistance requirement is

$$R_{ths} = \frac{T_{hot} - T_{amb}}{\text{Power}} = \frac{35^{\circ}\text{C} - 25^{\circ}\text{C}}{100\text{W} + 18.2\text{A} \times 9.6\text{V}} = \frac{10^{\circ}\text{C}}{100\text{W} + 18.2\text{A} \times 9.6\text{V}} = 0.036^{\circ}\text{C/W}$$

**Example 6.7: Thermoelectrically enhanced heat sink**

A switching semiconductor device dissipates 120W. Figure 6.42 shows the thermal resistor equivalent network and associated resistances for cooling system designs based on:

- $T_{amb} = 40^{\circ}\text{C}$
- $R_{ghs-a} = 0.18 \text{ K/W}$
- $R_{es-hs} = 0.08 \text{ K/W}$
- $R_{\theta TIM2} = R_{\theta TIM3} = R_{\theta TIM4} = 0.2 \text{ cm}^2 \text{ K/W}$
- $A_{TE} = 64\text{cm}^2$ , representing the area of four TECs, each  $4 \times 4 \text{ cm}$
- $A_{switch} = 9\text{cm}^2$

i. Using the TEC characteristics in figure 6.43, calculate the switch case temperature with and without a TEC, and the effective thermal resistance in each case.

ii. What is the maximum heatsink thermal resistance which when exceeded does not justify using TECs.

**Solution**

i. For the **no-TEC case**, the switch heat load is 120W from a  $30 \times 30 \text{ mm}$  package. The package is mounted to a heat sink using thermal grease with a TIM2 thermal resistance of  $0.2 \text{ m}^2 \cdot ^{\circ}\text{C/W}$ . The sink to ambient thermal resistance comprises two components; a spreading component due to the small heat input area, and the fin to ambient component as shown in Figure 6.42.

From an equivalent Ohms law calculation, the case temperature without a TEC is

$$T_c = T_{amb} + P_D \times (R_{\theta fins} + R_{\theta spread} + R_{\theta TIM2} / A_{switch})$$

$$T_c = 40^{\circ}\text{C} + 120\text{W} \times (0.18\text{K/W} + 0.08\text{K/W} + 0.2\text{cm}^2\text{K/W} / 9\text{cm}^2) = 73.9^{\circ}\text{C}$$

This equates to a case to ambient thermal resistance of

$$R_{ic-amb} = \frac{(T_{case} - T_{amb})}{P} = \frac{(73.9^{\circ}\text{C} - 40^{\circ}\text{C})}{120\text{W}} = 0.283^{\circ}\text{C/W}$$

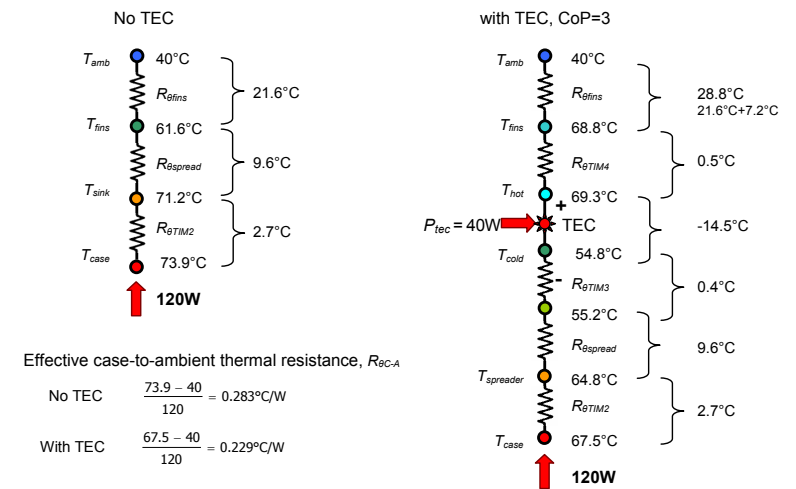

Effective case-to-ambient thermal resistance,  $R_{eC-A}$

No TEC	$\frac{73.9 - 40}{120} = 0.283^{\circ}\text{C/W}$
With TEC	$\frac{67.5 - 40}{120} = 0.229^{\circ}\text{C/W}$

Figure 6.42. Typical thermal resistor equivalent networks with and without a TEC.

Although a TEC adds additional thermal interfaces, it interposes a negative  $\Delta T$  in the thermal path. Also a TEC allows a simpler heat sink, one designed for a uniform heat input where spreading in the heat sink is not necessary.

**With TECs**, assume the four TECs operate with a CoP of 3. For practical applications of switch cooling, the CoP will likely be between 2 and 3.5, as shown in figure 6.43a, corresponding to TEC  $\Delta T$ 's between 10 and  $20^{\circ}\text{C}$ .

- For a CoP greater than 3.5, sufficient  $\Delta T$  is not generated by the TEC to offset the additional interface and heat sink rise and still provide measurable performance improvement.
- For a CoP less than 2, considerable additional input electrical power must be supplied and consequently dissipated by the heat sink.

For the 120W switch heat dissipation, from equation (6.35), a CoP of 3 equates to a TEC input power of 40W and an optimal TEC  $\Delta T$  of about  $-14.5^{\circ}\text{C}$  from figure 6.43. This 40W must be dissipated by the heat sink in addition to the switch 120W heat load, thus raising the heat sink temperature by  $40\text{W} \times 0.18^{\circ}\text{C/W} = 7.2^{\circ}\text{C}$ . Multiple TECs cover the heat sink area (total TEC area of  $64\text{cm}^2$ ). Thus the heat sink has a much larger heat input area compared to the no-TEC case thereby eliminating the need for a thick copper base plate ( $0.08^{\circ}\text{C/W}$  assumed) or embedded multiple heat pipes to spread the heat. The need for spreading is moved from the heat sink to the cold side of the TEC. This cold side spreader could be a heat pipe assembly, vapour chamber, or solid copper spreader, with are cost, performance, and weight tradeoffs for each case.

$$T_c = T_{amb} + P_d \times (R_{\theta TM2} + R_{\theta spread} + R_{\theta TM3}) - T_{TEC} + (P_d + P_{TEC}) \times (R_{\theta TM4} + R_{\theta fins})$$

$$= 40^\circ\text{C} + 120\text{W} \times (0.2 / 9 + 0.08 + 0.2 / 64) - 14.5^\circ\text{C} + (120\text{W} + 40\text{W}) \times (0.2 / 64 + 0.18)$$

$$= 40^\circ\text{C} + 12.7^\circ\text{C} - 14.5^\circ\text{C} + 29.3^\circ\text{C}$$

$$T_c = 67.5^\circ\text{C}$$

With the TEC, the case temperature decreases from 73.9°C to 67.5°C, a reduction of approximately 6.4°C, resulting in a 19% reduction in  $R_{\theta c-amb}$  for the 120W case. Note that the TEC actually operated with a 14.5°C negative  $\Delta T$ , yet the case temperature was reduced by only 6.4°C. More than half of the negative  $\Delta T$  from the TEC must be used to offset the additional interface losses and additional rise in heat sink temperature due to the TEC 40W input power.

$$\Delta T_{net} = \Delta T_{TE} + \Delta T_{interfaces} + \Delta T_{heatsink}$$

$$= -14.5 + 0.5 + 0.4 + 7.2 = -6.4^\circ\text{C}$$

Also, it should be noted that for the baseline system without the TEC, the 0.283°C/W thermal resistance is a constant with respect to heat load. For the TEC, the 0.229°C/W is not a constant with respect to heat load and accurately represents the thermal resistance for the 120W heat load only.

No gain in using a TEC approach results when the TEC thermal drop of 14.5°C is the same as the temperature rise – when the junction operating temperature is the same by both cooling methods.

ii. With a poor heat sink with a fin to ambient thermal resistance of 0.362°C/W instead of 0.18°C/W (with all other parameters maintained), the additional heat sink temperature rise due to the 40W TEC power increases from 7.2 to 14.5°C (0.362°C/W x 40W). The TEC gains become null and void.

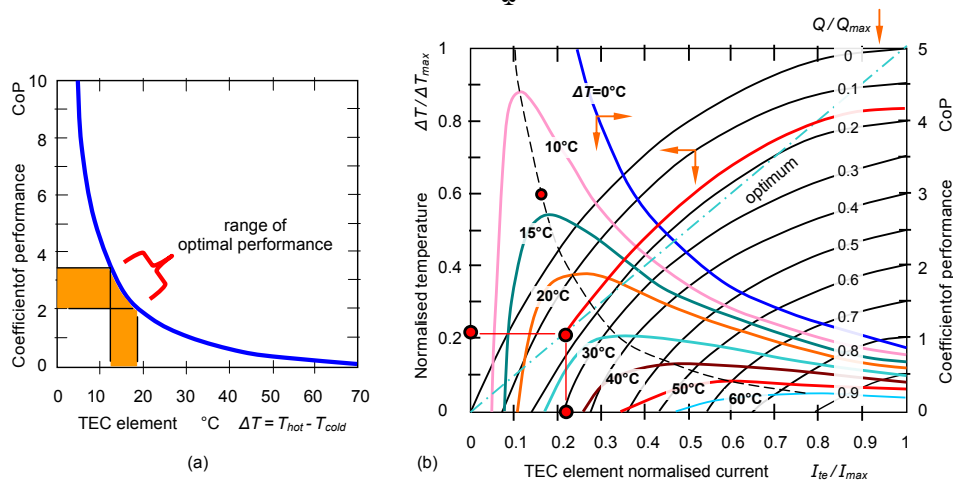

Figure 6.43. Generic  $\text{Bi}_2\text{Te}_3$  thermoelectric characteristics: (a) theoretical optimum (maximum) CoP versus  $\Delta T$  and (b) CoP as a function of current and generic thermoelectric performance curves.

Using examples 6.6 and 6.7 as a benchmark cases, when considering utilising a TEC:

- The TEC should operate near its maximum (optimum) CoP for the  $\Delta T$  chosen. As shown in Figure 6.43b, off-optimum operation results in significantly higher TEC power consumption (lower CoP). This results in a larger  $\Delta T$  across the hot side thermal interface and a larger additional rise in heat sink temperature, thus reducing the net gain from the TEC negative  $\Delta T$ . In addition, for the same CoP and thus the same input power, an off optimum TEC will not achieve the same  $\Delta T$ , thus further reducing the  $\Delta T_{net}$ .
- Analysis of Figure 6.42 shows there will be cases when a TEC should not be used - even if it is optimally designed. Even for an optimally designed TEC that behaves according to Figure 6.43a, if the heat sink performance is poor, the additional rise in heat sink temperature,  $\Delta T_{hs-amb}$  will offset more of the negative  $\Delta T$  from the TEC..

- The calculations in Example 6.6 were performed at the design power heat dissipation at the maximum ambient conditions 40°C. Typically, the switch may not operate for prolonged periods at these extreme conditions. When the switch heat dissipation is less than 120W or when the ambient is less than the maximum, the realized TEC CoP can be significantly greater, rising exponentially as the required TEC  $\Delta T$  is decreased (see Figure 6.43a). CoPs higher than 5 would be likely under typical operating conditions when only small  $\Delta T$  would be required by the TEC in order to maintain the maximum junction temperature below its specification. Likewise, operating the TEC at a constant input power under these non-peak conditions offers the opportunity for significant reductions in fan speed with favourable acoustic benefits.

**TEC requirements**

In the TE enhanced heat sink example 6.7, four TECs and a large spreader were utilized, where each TEC pumped 30W giving the required total of 120W. The generalized thermoelectric performance curve given in Figure 6.43b gives an indication of the type of TEC required. For a CoP of 3 operation, the optimum  $\Delta T$  is 14.5°C (figure 6.43a). For a typical TEC with a  $\Delta T_{max}$  of about 67°C, the ratio of  $\Delta T / \Delta T_{max}$  is about 0.21. From Figure 6.43b, the curve for optimum (lowest power) operation,  $P/P_{max}$  is approximately 0.17. Therefore, for a 30W TEC heat load, the  $P_{max}$  for each TEC should be approximately  $30\text{W} / 0.17 = 176\text{W}$ . The four TECs and a large cold side spreader add cost and weight to the system. A single TEC with partial spreading of the heat prior to the TEC and additional spreading between the TEC and heat sink could offer some performance/cost tradeoffs. However, if the entire heat from the switch were pumped by a single TEC, the  $P_{max}$  of that single TEC would need to be  $120\text{W} / 0.17 = 700\text{W}$ , which exceeds available limits of about 550W (for  $\Delta T = 0$ ).

**6.13.2 Superlattice and heterostructure cooling**

The strategy to improve thermoelectric cooling has turned to the nano scale level, where coherent and incoherent transport plays an important role in electron and phonon diffusion. ZT values (a figure of merit parameter, see Chapter 28) between 2 and 3 at room temperature are obtained with  $\text{Bi}_2\text{Te}_3/\text{Se}_2\text{Te}_3$  superlattices. Cooling power density is as high as  $700\text{W}/\text{cm}^2$  at 353 K compared to  $1.9\text{W}/\text{cm}^2$  in the bulk material, figure 6.44.

Thin-film, based on SiGe/Si, gives a cooling power density of almost  $600\text{W}/\text{cm}^2$  for a temperature difference of 4K below ambient for a  $40 \times 40$  micrometer area. A superlattice approach produces a ZT larger than 1.4.

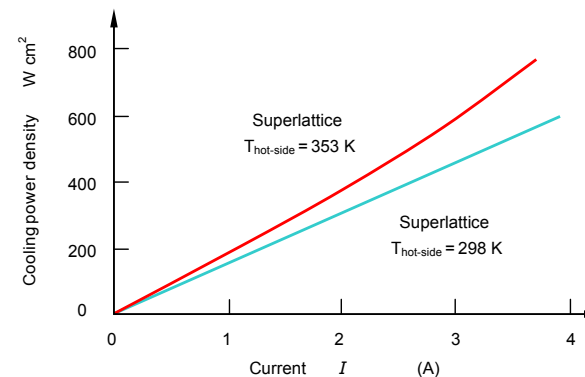

Figure 6.44. Estimated power density for superlattice devices as a function of current.

**6.13.3 Thermionic and thermotunnelling cooling**

Thermionic cooling is based on the principle that a high-work-function cathode preferentially emits hot electrons. Materials available have a work function of 0.7eV or higher, which limits the use to the higher temperature ranges (>500K). Vacuum thermionic devices based on resonant tunnelling have cooling capabilities of 20 to 30°C with  $\text{kW}/\text{cm}^2$  cooling power densities achievable. However, since the operating currents for the device are as high as  $105\text{A}/\text{cm}^2$ , effects such as Joule heating ( $I^2R$ ) at the metal-semiconductor contact resistance and reverse heat conduction limit cooling to  $<1^\circ\text{C}$ . Devices based on quantum tunnelling through a small gap, with the spacing between the cathode and the anode of the order of 10 nm provide much larger cooling power than thermoelectric superlattice coolers, specifically  $10\text{kW}/\text{cm}^2$  for 50K cooling at room temperature.



## 6.14 Cooling by phase change

### Phase change materials and heat accumulators

*Phase change materials* for electronics thermal management are limited to applications where time-dependent phenomena play a role.

In the case of *heat accumulators*, the use of composite materials based on a granulated open-porous matrix filled with a hygroscopic substance is an approach to accumulate heat. The advantage is a significant increase in the heat that can be stored as compared to sensible heat (surrounding heat, potential energy) and latent heat. For example, for a 100°C temperature rise, copper absorbs 40kJ/kg. Evaporation of water is associated with an absorption of 2260kJ/kg. The enthalpy of a reversible chemical reaction can reach a value of 7000kJ/kg. A principal advantage of reversible chemical reactions for heat accumulation is their ability to store the accumulated energy for a long time, if the reaction is controlled by the presence of either a catalyst or a reagent.

### Phase change material thermal properties

When power electronics is operated under transient conditions, increasing the thermal capacitance is a useful technique for limiting temperature increases and/or minimizing the performance requirements of a heat sink. An effective method of increasing thermal capacitance is to utilise a material that undergoes a change of phase at a desirable temperature – at which temperature there is thermal energy transfer associated with the change of phase. Utilizing phase change for temporary thermal energy storage has the benefit of allowing heat rejection to occur over a longer time interval, which in turn allows a smaller heat sink. Examples of phase change that have been used in power electronics cooling include solid-liquid, liquid-vapour, and solid-solid (for example, crystalline structure to amorphous). A solid-liquid phase change is most common for systems that require reuse of the phase change material (PCM). The thermal energy required to melt the PCM is described as the *latent heat of fusion* and *latent heat of vaporisation* is applicable to a liquid to gas phase change. Directing the waste heat from the power electronics into the PCM can result in a near isothermal heat sink while the PCM is changing state - melting or vaporising.

Selecting a PCM requires knowing the range of expected temperatures (the melt or vapour temperature of the PCM must be high enough such that state change does not occur until needed). Another specification is duration index, *DI*, which is a comparison of time of the PCM at constant temperature during the phase change.

$$DI = \frac{h_f \times \rho}{\Delta T} \quad (6.36)$$

The list of candidates is restricted when issues such as material compatibility, electrical conductivity, toxicity, availability of thermal property data, and cost are considered.

### Heat of fusion (solid to liquid)

Desirable characteristics of a solid-liquid PCM include high heat of fusion per volume (*DI*), congruent melting and freezing characteristics, high thermal conductivity, minimal supercooling, and low thermal expansion. Table 6.17 lists four categories of solid-liquid PCMs with melting temperatures in the range of 40° to 120°C, with water characteristics provide as a reference.

The main drawback of metal eutectic PCMs is high density, resulting in heavy package solutions. Salt hydrates have handling and safety issues. Two salt hydrates with high volumetric heat of fusion are Lithium Nitrate Trihydrate ( $679 \times 10^6 \text{ J/m}^3$ ) and Barium Hydroxide Octahydrate ( $656 \times 10^6 \text{ J/m}^3$ ). The first is a severe oxidizer with a moderate health rating and the second carries a severe health warning. The organic non-paraffin category has the largest variability. Acetamide is an example of a non-paraffin organic PCM that melts at 81°C and has only moderate handling and material compatibility issues.

The organic paraffins represent a reasonable compromise between handling and performance and are available in a wide range of melt temperatures. In general, higher melt temperature paraffins are more expensive, especially for high purity levels. The low thermal conductivity of these materials usually requires the use of an imbedded matrix material to help conduct heat into the PCM. The volume change between solid and liquid states limits their packaging density.

**Table 6.17: General solid-liquid PCM thermo-physical characteristics**

property		Inorganic water	Organic paraffin	Organic non-paraffin	Inorganic salt hydrate	Inorganic metal eutectic
Phase change temperature	°C	0	37	2 - 164	7 - 117	< 0
Latent heat of fusion $h_f$	kJ / kg	334	230 - 290	120 - 240	170 - 340	30 - 90
Latent heat of vap $h_v$	$\frac{\text{kJ}}{\text{m}^3} \times 10^2$	22.7	190 - 240	140 - 430	250 - 660	300 - 800
Density $\rho_l$	kg / m <sup>3</sup>	1000	≈ 810	900 -1800	900 - 2200	≈ 8000
Thermal conductivity $\lambda$	W / mK	0.6	≈ 0.25	≈ 0.2	0.6 - 1.2	≈ 20
Duration Index <i>DI</i>	J/ m <sup>3</sup> K	13.32	2.96	5.44		
Thermal expansion		low	high	moderate	low	low
Congruent melt		yes	yes	some do	most do not	yes
Supercool		yes	no	no	most do	no
Corrosion		low	low	some are	highly	some are
Toxicity		no	no	some are	highly	some are
Advantages			Simple to use No nucleating agent		Cheap Non-flammable	
Disadvantages			More expensive Some combustible		Careful preparation Need stabilising additives	

**Table 6.18: Heat of vaporization at standard temperature and pressure (see Table 6.12)**

Substance	Boiling Point	Heat of Vaporization
	°C	kJ / kg
Helium	-268.9	21
Hydrogen	-252.8	461
Nitrogen	-195.8	199
Propane	-42.1	427
R12	-38.8	165
Ammonia	-33	1369
R134a	-26	178
Fluoroketone	49	88
Acetone	56	518
FC-72	56	88
Methanol	64.7	1100
Ethanol	78.4	846
Water	100	2256
Ethylene glycol	197	800
Glycerine	290	974
Mercury	347	295

### Heat of vaporization (liquid to vapour)

The energy required to change a substance from a liquid state to a vapour state is termed the *heat of vaporization*, and is directly related to overcoming the intermolecular bonding forces in the liquid state. The energy released when a vapour is condensed to a liquid is equal to the heat of vaporization but has an opposite sign and is commonly termed the *heat of condensation*. The most common applications of this thermodynamic property in power electronics cooling are associated with boiling heat transfer.

Compared to a solid to liquid phase change, the volume change associated with a liquid to vapour phase change is significantly larger, often greater than two orders of magnitude. Even though heats of vaporization are typically larger than heats of fusion for a particular material, the large volume change limits the ability to take advantage of this property for simple thermal energy storage. When it is not required to contain and reuse the vapour, such as in a single use application, expendable coolants that undergo a liquid-vapour phase change as they absorb heat are a consideration.

More common in power electronics cooling, the use of heat of vaporization occurs in closed systems where heat removal is augmented by the vaporization property and then released elsewhere in the system when the vapour is condensed. Examples for cooling hardware using this property include heat pipes, pumped refrigerant, and spray cooling. The operating pressure of these systems can be adjusted to provide an attractive boiling point for the coolant. Desirable qualities for a coolant that will operate in a two-phase mode include a high heat of vaporization, acceptable boiling temperature and pressure, low corrosion potential, low toxicity, environmentally friendly, and low cost. The heat of vaporization and melting temperature for several common substances at standard temperature and pressure are listed in Table 6.18.

### Reading list

Fishenden, M. and Saunders, O. A., *An Introduction to Heat Transfer*,  
Oxford University Press, 1982.

<http://www.electronics-cooling.com>

<http://www.qats.com/qpedia.asp>

<http://www.lytron.com/>

<http://www.aavidthermalloy.com/>

<http://www.1-act.com/>

<http://pcmproducts.net/>

### 6.15 Appendix: Properties of substrate and module materials

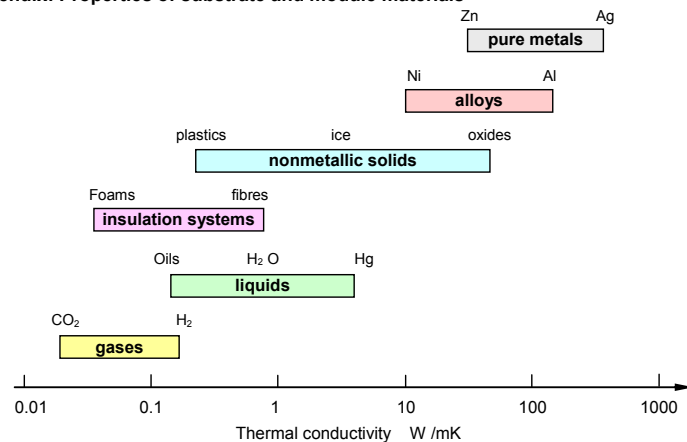

Table 6.19: Coolant properties

Material	Specific Heat	Density	Thermal Conductivity
	$c_p$	$\rho_l$	$\lambda$
	J/kgK	kg/m <sup>3</sup>	W/mK
Coolanol 25	1,838	903	0.12
Diala-X	1,840	870	0.14
20/80 EGW Solution	3,817	1023	0.57
50/50 EGW Solution	3,283	1064	0.39
Fluorinert®, FC-77	1,028	1771	0.063
Hydraulic Oil	1,842	868	0.12
Polyalphaolefin	2,180	794	0.14
SAE 10W Oil	1,901	875	0.12
SAE 30W Oil	1,901	875	0.12
Stainless Steel, 316	500	8025	16.20
Water, H <sub>2</sub> O	4,184	998	0.59
Air	1,008	1.1	0.27
Mercury	137	13,800	137

### CONVERSIONS

#### STATIC PRESSURE

$$1 \text{ mmH}_2\text{O} = 0.0394 \text{ inch H}_2\text{O}$$

$$1 \text{ mmH}_2\text{O} = 9.8 \text{ Pa}$$

$$1 \text{ mmH}_2\text{O} = 25.4 \text{ mm H}_2\text{O}$$

$$1 \text{ Pa} = 0.102 \text{ mm H}_2\text{O}$$

$$1 \text{ inch H}_2\text{O} = 249 \text{ Pa}$$

$$1 \text{ Pa} \equiv 1 \text{ N/m}^2 = 10^{-5} \text{ bar} = 10^{-6} \text{ N/mm}^2 = 0.102 \text{ kp/m}^2 = 0.987 \times 10^{-5} \text{ atm} = 0.0075 \text{ Torr} = 145.04 \times 10^{-6} \text{ psi}$$

#### AIRFLOW

$$1 \text{ m}^3/\text{min} = 35.31 \text{ ft}^3/\text{min} \text{ (cfm)}$$

$$1 \text{ cfm} = 0.0283 \text{ m}^3/\text{min}$$

$$1 \text{ m}^3/\text{min} = 16.67 \text{ litre /s}$$

$$1 \text{ cfm} = 0.472 \text{ litre /s}$$

$$1 \text{ litre /s} = 0.06 \text{ m}^3/\text{min}$$

$$1 \text{ cfm} = 1.7 \text{ m}^3/\text{h}$$

$$1 \text{ litre/s} = 3.6 \text{ m}^3/\text{h}$$

$$1 \text{ m}^3/\text{s} = 3600 \text{ m}^3/\text{h}$$

**Table 6.20 Heat pipe working fluids**

medium	Melting point °C	Boiling point @ atmospheric pressure °C	Useful range °C
Helium	-271	-261	-271 to -269
Nitrogen	-210	-196	-203 to -160
Ammonia	-78	-33	-60 to 100
Pentane	-130	28	-20 to 120
Acetone	-95	57	0 to 120
Methanol	-98	64	10 to 130
Flutec PP <sup>n</sup>	-50	76	10 to 160
Ethanol	-112	78	0 to 120
Heptane	-90	98	0 to 130
Water	0	100	0 to 150
Toluene	-95	110	30 to 200
Flutec PP9	-70	160	50 to 200
Thermex	12	257	0 to 225
Mercury	-39	361	150 to 350
Caesium	29	670	250 to 650
Potassium	62	774	500 to 1000
Sodium	98	892	600 to 1200
Lithium	179	1340	1000 to 1800
Silver	960	2212	1800 to 2300

Blank

**Problems**

1	Explain the difference between fans, blowers, and compressors.
2	Which fan is used for moving flows against relatively low pressures? (a) radial fan (b) backward inclined fan (c) forward curved fan (d) axial fan
3	If efficiency is the main consideration, which fan is selected? (a) radial fan (b) backward inclined fan (c) forward curved fan (d) axial fan
4	Which fan is ideally suited for dusty conditions? (a) radial fan (b) backward inclined fan (c) forward curved fan (d) axial fan
5	System resistance refers to (a) static pressure (b) velocity pressure (c) total pressure (d) differential pressure
6	System resistance varies as (a) square of flow rate (b) cube of flow rate (c) proportional to the square root (d) directly with flow rate
7	The intersection of the system characteristic curve and the fan operating curve is called (a) design point (b) operating point (c) free flow point (d) shut off point
8	Varying the rpm of a fan by 10% varies the pressure by (a) 19% (b) 29% (c) 10% (d) no change
9	Varying the RPM of a fan by 10% varies the flow by (a) 27% (b) 20% (c) 30% (d) no change
10	Varying the rpm of a fan by 10% varies the power by (a) 27% (b) 37% (c) 10% (d) no change
11	Explain the factors which change the system resistance.
12	What are the affinity laws as applied to centrifugal fans?