

CHAPTER 28

Energy Sources and Storage - Secondary Sources

The progressive proliferation of embedded and distributed generation with renewable energy sources has spurred research into alternative energy sources and storage methods. This chapter is concerned with secondary energy sources, viz., so called super or double-layer capacitors, electro-chemical batteries, and thermoelectric modules. Their energy and power density capabilities (and those of primary electrical sources) have been put into context by considering conventional energy sources in Chapter 27.1, specifically the hydrocarbons and hydrogen gas.

In electrical terms, primary and secondary energy sources are defined as follows.

Primary source is not a reversible energy source. During energy discharge, the original states are permanently changed as electrical energy is released until the original energy reactant sources, or any one of them, are depleted. A primary cell can be used only once.

Secondary source is reversible and the original states can be reconstituted by the application of an electrical potential that injects conversion energy into the source. A secondary cell can source and sink energy many times.

28.1 Batteries

An electrochemical battery cell is an 'electron pump' that stores energy in chemical form in its active materials and can convert this stored chemical energy to electrical energy on demand, typically by means of an electrochemical oxidation-reduction reaction or a physical reaction.

This energy conversion is achieved by a chemical reaction in the battery that releases electrons. If a load is placed across the battery terminals, the chemical reaction produces electrical power. The process can be reversible. If electrical energy is directed into the battery (charging the battery), the chemical reaction reverses and restores the battery to a fully charged condition.

Cells are classified as either primary cells or secondary cells, depending on whether or not the electrochemical cell is rechargeable.

Primary electrochemical cell: The electrochemical reaction is not reversible. During discharge, the chemical compounds are permanently changed and electrical energy and heat are released until the original compounds, or any one of them, are depleted. A primary cell is assembled in the charged state, discharged during utilisation, used only once until discharged, then discarded, possibly involving recycling of components.

Secondary electrochemical cell: The electrochemical reaction is reversible and the original chemical compounds can be reconstituted by the application of an electrical potential between the electrodes injecting energy into the cell. The cell discharge and charge current directions are opposite. A secondary cell can be discharged and recharged many times. It is usually assembled in a discharged state and has to be charged before under-going discharged.

Batteries come in a wide range of types, sizes and shapes, from wafer-thin to button-size devices to large industrial battery systems. All can be categorised as either primary storage or secondary storage batteries. Batteries function best at room temperature (except lithium polymer batteries) and elevated temperature operation dramatically increases the internal resistance and shortens battery lifetime.

Primary batteries

Primary batteries have the following properties:

- Designed as a single use battery, used until exhausted then discarded or recycled after depletion
- High impedance which translates to long-life energy storage, and for low current loads
- Available in carbon-zinc, alkaline, silver oxide, lithium, zinc air and some lithium metal batteries (like lithium-thionyl-chloride)
- Lithium-thionyl-chloride batteries, for example, come in cylindrical form factors of AAA to D. Larger C and D size lithium-thionyl-chloride batteries are a chemical hazard and are restricted when transported by air
- Operating temperature range is typically -40°C to +85°C

Although primary cells may consist of the same active materials as secondary battery types, they are constructed so that only one continuous or intermittent discharge can be obtained.

Secondary batteries

Secondary batteries are recharged by a flow of direct current through them in a direction opposite to the current flow on discharge. By recharging after discharge, a higher state of oxidation is created at the positive electrode plate (cathode) and a lower state at the negative electrode plate (anode), returning the plates to approximately their original charged condition.

Secondary batteries have the following properties:

- Designed to be recharged
- Can be recharged up to 1,000 times depending on the usage and battery type
- Very deep discharges result in a shorter cycle life, whereas shorter discharges result in long cycle life for most secondary batteries
- Charge time varies from one to twelve hours, depending upon battery condition, temperature, depth of discharge, and other factors
- Include NiCd, lead-acid, NiMH, some lithium metal and Li-ion batteries
- Lead-Acid and NiCd batteries are toxic and are subject to disposal regulations

Some of the general limitations suffered by secondary batteries are limited life, limited power capability, low energy-efficiency, and disposal concerns.

The secondary cell is the subject of this section. The primary cell is not specifically considered further.

28.2 The secondary electro-chemical cell

Each electro-chemical energy cell consists of at least three, sometimes four, components

- The **cathode** or positive electrode (the oxidising electrode) accepts electrons from the external circuit and is chemically reduced during the electrochemical (discharge) reaction. It is usually a metallic oxide or a sulphide. The cathodic process is the reduction of the oxide ion - anion - to leave the metal. (To gain or to accept electrons is termed reduction). The cathode is the half-cell with the higher electrode potential.

- The **anode** or negative electrode (the reducing or fuel electrode) gives up electrons to the external circuit and is oxidised during the electrochemical (discharge) reaction. It is generally a metal or an alloy. The anodic process is the oxidation of the metal to form metal ions - cations. (To lose or to supply electrons is termed oxidation). The anode is the half-cell with the lower (least positive) electrode potential.
- The **electrolyte** (the ionic conductor) provides the medium for transfer of charge in the form of ions inside the cell in either direction between the cathode and anode. The electrolyte is typically a solvent containing dissolved chemicals providing ionic conductivity. It should be a non-conductor of electrons to avoid internal self-discharge of the cell.
- The **separator** electrically isolates the positive and negative electrodes but allows ions to travel back and forth in the electrolyte, between the electrodes.

The operation of lead-acid and nickel-cadmium batteries are based on oxidation and reduction chemistry, called REDOX. The nickel-metal-hydride and lithium-ion batteries are not based on REDOX reactions, but rather involve an ion transfer mechanism called *intercalation*, which is the insertion and extraction of ions into and out of the crystalline lattice of an electrode, without chemically altering its crystal structure.

28.2.1 REDOX galvanic action

Galvanic action is when chemical reactions produce electricity, while electrolysis is the reverse process where electricity is used to produce chemicals.

Different metals have different affinities for electrons. When two dissimilar metals (or metal compounds) are put in contact or connected through a conducting medium there is a tendency for electrons to pass from the metal with the smaller affinity for electrons, which becomes positively charged, to the metal with the greater electron affinity which becomes negatively charged. A potential difference between the metals will therefore build up until it just balances the tendency of the electron transfer between the metals. At this point, the 'equilibrium potential' is that which balances the difference between the propensity of the two metals to gain or lose electrons.

A battery can be considered as an electron pump. The internal chemical reaction within the cell between the electrolyte and the negative metal electrode produces a build-up of free electrons, each with a negative charge, at the cell's negative terminal - the anode. The chemical reaction between the electrolyte and the positive electrode (the cathode) inside the cell produces an excess of positive ions (atoms that are missing electrons, thus with a net positive charge) at the cell cathode. The electrical (pump) pressure or potential difference between the positive and negative electrodes is called voltage or electromotive force, EMF.

i. The Discharge Process

When the cell is fully charged there is a surplus of electrons on the anode giving it a negative charge and an electron deficiency on the cathode giving it a positive charge, resulting in a potential difference between the cell electrodes.

When the external electrical circuit is completed the surplus electrons flow in the external circuit from the negatively charged anode which loses its charge to the positively charged cathode which accepts it, neutralising its positive charge. This action reduces the potential difference across the cell to zero. The external circuit electron flow is balanced by the internal flow of positive ions through the electrolyte from the anode to the cathode.

Since the electrons are negatively charged, the electrical current they conventionally represent flows in the opposite direction, from the cathode (positive terminal) to the anode (negative terminal).

The battery's chemical reaction continues to generate electrical current until at least one of the active materials involved in the reaction is depleted or the external load connection is removed.

ii. The Charging Process

The charging process strips electrons from the cathode leaving it with a net positive charge and forces them onto the anode giving it a negative charge. The electrical energy pumped into the cell transforms the active chemicals back to their original state.

iii. Half-cell reaction

Chemical reactions occur on both the anode electrode and the cathode electrode. Half cell reaction refers to the chemical processes occurring at each electrode (half-reactions), namely the negative anode and the positive cathode.

The cell is modelled as two half-cells. Gibbs free energy equation ($\Delta G = -nFE^0$, see Chapter 27.14, equation (27.14) and Chapter 28.8, equation (28.9)) is used to calculate electrode potentials and characterise the chemical reactions within the cell. The cell voltage or EMF to force the external current from a cell is the difference in the standard electrode potentials of the two half-cell reactions under standard conditions. The actual voltage of a chemical cell is dependant on the temperature, pressure,

and concentration of the reactants and products. The Nernst equation ($E = E^0 - RT/nF \times \ln N$, see Chapter 27.14, equation (27.18) and Chapter 28.8, equation (28.10)) can be used to calculate the EMF for non-standard cell conditions. The cell EMF decreases as the concentration of the active chemicals diminishes as they are consumed, until one of the reactants is exhausted. The half-cell zero reference potential is defined to be zero for the hydrogen electrode. All the equations are written as reductions and the two half-reaction potentials add to give the overall cell potential.

The cathodic reaction can be represented as:

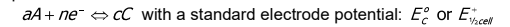

where a is the number of moles of A, etc.

The anodic reaction can be represented as:

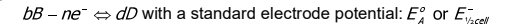

The overall reaction is given by:

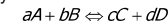

The cell potential under standard conditions (25°C, 1 mole, 1 Atmosphere) is

$$E_{\text{cell}}^0 = E_{\frac{1}{2}\text{cell}}^+ - E_{\frac{1}{2}\text{cell}}^- = E_C^0 - E_A^0 \quad (28.1)$$

The alkaline half-cell reactions, during discharge, for example, are shown in Table 28.1. The half-cell equations are reversed during cell charging, although the standard alkaline cell may not be rechargeable, that is primary and secondary variations exist.

Table 28.1: Half-cell electro-chemical equations for the alkaline cell

Location	Reaction (discharge)	185A-hr/kg	Potential
Anode - oxidation	Negative terminal	$Zn_{(s)} + 2OH_{(aq)} \rightarrow ZnO_{(s)} + H_2O + 2e^-$	$E_{\frac{1}{2}\text{cell}}^- = +0.76V$
Cathode - reduction	Positive terminal	$2MnO_{2(s)} + H_2O + 2e^- \rightarrow Mn_2O_{3(s)} + 2OH_{(aq)}$	$E_{\frac{1}{2}\text{cell}}^+ = +2.31V$
Net REDOX reaction			$E_{\text{cell}}^0 = 1.55V$

Table 28.2: Strength of oxidizing and reducing agents (25°C, 1 mol, 1 Atmosphere)

Anode Materials		Cathode Materials	
(Negative Terminal)		(Positive Terminal)	
BEST - Most Negative		BEST Most Positive	
Cathode (Reduction) Half-cell Reaction	Standard Potential $E_{\frac{1}{2}}^0$ (V)	Cathode (Reduction) Half-cell Reaction	Standard Potential $E_{\frac{1}{2}}^0$ (V)
$Li^+_{(aq)} + e^- \rightarrow Li_{(s)}$	-3.045	$F_{2(g)} + 2e^- \rightarrow 2F^-_{(aq)}$	+2.87
$K^+_{(aq)} + e^- \rightarrow K_{(s)}$	-2.925	$MnO_4^{2-} + 4H^+ + 2e^- \rightarrow MnO_{2(s)} + 2H_2O$	+2.257
$Ca^{2+}_{(aq)} + 2e^- \rightarrow Ca_{(s)}$	-2.766	$Co_3O_{4(s)} + 8H^+ + 2e^- \rightarrow Co^{2+} + 4H_2O$	+2.11
$Mg^{2+}_{(aq)} + 2e^- \rightarrow Mg_{(s)}$	-2.353	$PbO_{2(s)} + SO_4^{2-}_{(aq)} + 4H^+_{(aq)} + 2e^- \rightarrow PbSO_{4(s)} + 2H_2O_{(l)}$	+1.685
$Al^{3+}_{(aq)} + 3e^- \rightarrow Al_{(s)}$	-1.66	$FeO_4^{2-} + 6H^+ + 3e^- \rightarrow Fe(OH)_2^+ + 2H_2O$	+1.56
$Zn^{2+}_{(aq)} + 2e^- \rightarrow Zn_{(s)}$	-0.763	$MnO_2 + 4H^+ + 2e^- \rightarrow Mn^{2+} + 2H_2O$	+1.23
$Fe^{2+}_{(aq)} + 2e^- \rightarrow Fe_{(s)}$	-0.440	$O_{2(g)} + 4H^+ + 4e^- \rightarrow 2H_2O$	+1.229
$Ni^{2+}_{(aq)} + 2e^- \rightarrow Ni_{(s)}$	-0.250	$Ag_2O_{(s)} + 2H^+ + 2e^- \rightarrow 2Ag_{(s)} + H_2O$	+1.173
$Pb^{2+}_{(aq)} + 2e^- \rightarrow Pb_{(s)}$	-0.126	$HgO_{(s)} + 2H^+ + 2e^- \rightarrow Hg_{(l)} + H_2O$	+0.93
$2H^+ + 2e^- \rightarrow H_{2(g)}$	0.00	$CuO_{(s)} + 2H^+ + e^- \rightarrow Cu^+ + H_2O$	+0.62
$Cu^{2+}_{(aq)} + 2e^- \rightarrow Cu_{(s)}$	+0.337	$NiOOH + H_2O + e^- \rightarrow Ni(OH)_2 + OH^-$	+0.49
$Ag^+_{(aq)} + e^- \rightarrow Ag_{(s)}$	+0.799	$NiO_{2(s)} + 2H_2O + 2e^- \rightarrow Ni(OH)_{2(s)} + 2OH^-$	+0.49

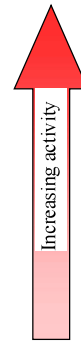

iv. Choice of active cell chemicals

The voltage and current generated by a galvanic cell is directly related to the types of chemical materials used for the electrodes and electrolyte.

The propensity of an individual metal or metal compound to gain or lose electrons in relation to another material is known as its electrode potential. Thus the strengths of oxidizing and reducing agents are indicated by their standard electrode potentials. Compounds with a positive electrode potential are used for anodes and those with a (more) negative electrode potential for cathodes. The larger the difference between the electrode potentials of the anode and cathode, the greater the EMF of the cell and generally the amount of energy that can be produced by the cell.

The Electrochemical Series is a table of metallic elements or ions arranged according to their electrode potentials, as shown in Table 28.2. The order shows the tendency of one metal to reduce the ions of any other metal below it in the series, at 25°C, standard pressure and 1mol of reactant.

Table 28.2 shows some common chemicals used for battery electrodes arranged in order of their relative electrode potentials. Lithium has the most negative standard potential, -3.045V, indicating that it is the strongest reducing agent. The strongest practical oxidizing agent is fluorine with the largest positive standard electrode potential of +2.87V. Although halogen acids have high electrode potentials, they are usually too aggressive with the electrodes to be used in normal cells. Metals are commonly used in cells as anode materials, but the cathode is commonly an oxide. That is, in Table 28.2, metals appear in the left columns while oxides appear in the right columns.

v. Gassing

Cells using aqueous (containing water) electrolytes are limited in voltage to less than 2.4V because the oxygen and hydrogen in water dissociate producing H₂ and O₂ in the presence of voltages above this voltage. Lithium batteries use non-aqueous electrolytes hence do not have dissociation problems and are available in voltages between 2.7V and 3.7V. However, the use of non-aqueous electrolytes result in such cells having relatively high internal impedance.

28.2.2 Intercalation action

From intercalation process theory, it is known that small ions (such as ions of lithium, sodium, and the other alkali metals) can fit in the interstitial spaces of a carbon graphite lattice crystal. These metallic molecules force the graphitic planes apart to fit numerous layers of metallic molecules between the carbon sheets. This is an efficient way to store the metal-ion in a battery.

The anode of a conventional alkali metal-ion cell is made from graphite (carbon), the cathode is a metal oxide, and the electrolyte is a metal salt in an organic solvent.

Both the anode and cathode are materials into which metal-ions insert and extract, termed intercalation. The process of metal-ions moving into the anode or cathode lattice is referred to as insertion, and the reverse process, in which metal-ions move out of the anode or cathode is referred to as extraction.

Using lithium as an example, the underlying chemical reaction that allows Li-ion cells to provide electricity (equations to the right) are:

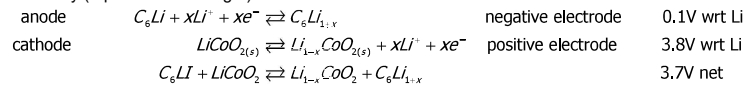

The lithium-ions are not oxidized; rather, they are transported to and from the cathode or anode, with the transition metal, cobalt, in LiCoO₂ being oxidized from Co³⁺ to Co⁴⁺ during charging, and reduced from Co⁴⁺ to Co³⁺ during discharge. At no stage is any alkali lithium metal present or involved.

The intercalation host electrodes have two key properties:

- Open crystal structures which allow the insertion and extraction of alkali metal-ions
- The ability to simultaneously accept compensating electrons - conductive

When **discharging** a cell, the metal-ions are extracted from the anode and inserted into the cathode, via the electrolyte, as shown in figure 28.1b. That is, alkali metal ions move through the electrolyte from the negative electrode to the positive electrode and attach to the carbon. The electrolyte is non-conducting to electrons. At the same time compensating electrons, which form the external circuit current, transfer from the positive to the negative electrodes, and are accepted by the internally arriving metal-ions, thereby balancing the equation.

When **charging** the cell, the reverse process occurs: metal-ions are extracted from the cathode and inserted into the anode, as shown in figure 28.1a. The metal ions move back to the anode from the carbon cathode, while external current electrons flow from the negative to positive electrodes. The anode graphite is a two-dimensional crystal structure, which under charging, is forced to laterally shift and simultaneously strain to 10% greater separation to accommodate the Li-ions. The lattice deformation is relieved when Li-ions are removed from the anode under cell discharge.

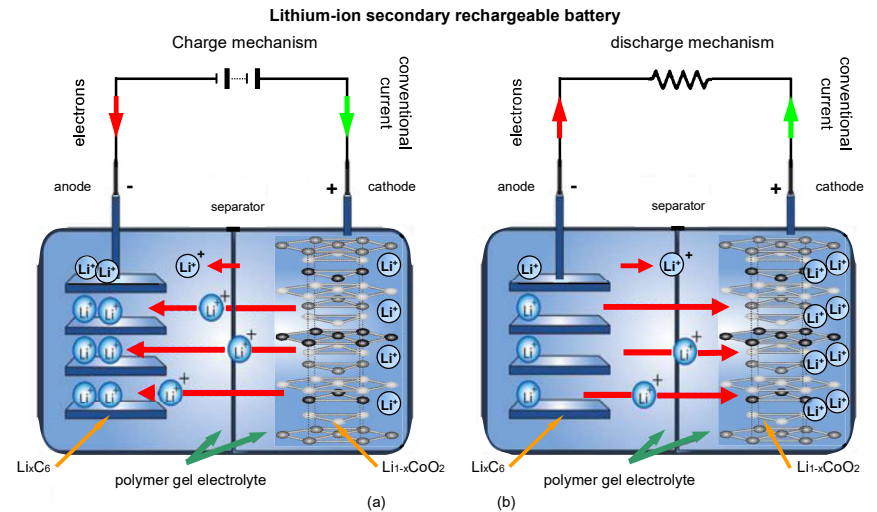

Figure 28.1. Cells charge mechanism and discharge mechanism.

28.3 Characteristics of secondary batteries

A wide range of secondary batteries exists, each offering different attributes, limitations, properties, etc. The four secondary batteries to be considered are:

- Lead-acid
- Nickel-cadmium
- Nickel-metal-hydride
- Lithium-ion

Electrochemical lead-acid and nickel-cadmium battery technologies are mature. The lead-acid battery is economical for high power applications where weight is of little concern. It is an inexpensive, robust technology, found extensively in automotive applications and UPS equipment. The nickel-cadmium battery has a higher energy density than the lead acid battery, and offers longer lifetimes, higher discharge rates and a wider operating temperature range than the lead-acid battery. The nickel-cadmium battery contains toxic metals, and is used in power tool applications.

The nickel-metal-hydride battery trades a higher energy density than nickel-cadmium for reduced cycle life. Importantly it uses non-toxic metals, and is used in satellites, mobile phones and laptops. Lithium-ion, a newer developing technology, offers higher again energy densities, but cell series connection poses sharing and balancing problems. Because of its high energy density properties, lithium-ion is being extensively used in notebook computers, mobile phones, and power tools.

Key technology properties and features of different battery technologies are summarised in tables 28.3a and 28.3b.

In Table 28.3a, lithium is the lightest metal, and has the highest standard potential. Lithium metal is volatile (with water and nitrogen in air) and has a low reactivity with many cathode materials and non-aqueous electrolytes. Because of the energy density potential offered by lithium-ion technologies, different cathode material types have emerged.

Table 28.3a. Anode capabilities of different metals

Anode	Symbol	Atomic Mass	Standard Potential	Density	Melting Point	Electrochemical Equivalence
		g	V	g/cm ³	°C	Ah/g
Lithium	Li	6.94	-3.05	0.54	180	3.86
Sodium	Na	23.0	-2.7	0.97	97.8	1.16
Magnesium	Mg	24.3	-2.4	1.74	650	2.20
Aluminium	Al	26.9	-1.7	2.7	659	2.98
Calcium	Ca	40.1	-2.87	1.54	851	1.34
Iron	Fe	55.8	-0.44	7.85	1528	0.96
Zinc	Zn	65.4	-0.76	7.1	419	0.82
Cadmium	Cd	112	-0.40	8.65	321	0.48
Lead	Pb	207	-0.13	11.3	327	0.26

Three key performance aspects should be defined, namely power density, energy density, and capacity.

i. **Power density (specific power):** *Volumetric Power density* is the ratio of the power available from a battery to its volume (W/litre). *Specific power* (or gravimetric power density) refers to the ratio of power to mass (W/kg). Comparison of power to cell mass is more common.

Power Density (W/kg) indicates how much power a battery can deliver on demand. Manganese and phosphate-based lithium-ion, as well as nickel-based chemistries, give the best performance. High power density cell uses are power tools, medical devices and transportation systems. The focus is on power bursts, such as drilling through heavy steel, rather than runtime.

ii. **Energy density (specific energy):** *Volumetric Energy density* refers to the ratio of a battery's available energy to its volume (Wh/litre). *Specific energy* (or gravimetric energy density) refers to the ratio of energy to mass (Wh/kg). The energy *W* is determined by the charge *q* that can be stored and the cell voltage *E*, that is, $W = q \times E$.

Energy Density (Wh/kg) is a measure of how much energy a battery can retain or store. The higher the energy density, the longer the possible runtime. Cell size and its chemistry determine energy storage density. Lithium-ion cells with cobalt cathodes offer the highest energy densities, 190Wh/kg. Typical applications are cell phones, laptops and digital cameras.

An Ah/kg rating can be determined from the cell standard voltage, *E* and energy density rating Wh/kg, while power and energy densities are related by time, $W = P \times t$, as shown in figure 28.2. An analogy between energy and power densities can be made with a water bottle. The size of the bottle is the energy density, while the opening area denotes the power density. A large volume bottle can carry a lot of water (energy), while a large opening can pour it quickly (power). A large container (energy) with a wide area mouth (power) is the best combination.

Table 28.3 shows some typical relative energy and power per unit weight examples of common secondary cell chemistries. In general, higher energy densities are obtained by using more reactive chemicals. But reactive chemicals tend to be unstable and require safety precautions. The energy density is also dependent on the quality of the active materials used in the cell construction, with impurities limiting cell capacity.

iii. **Capacity and battery rating, C-rate**

In general terms, the electrical energy capacity of a cell or battery is the amount of charge available expressed in ampere-hours, Ahr. An ampere, the unit of measurement used for electrical current, is defined as a coulomb of charge passing through an electrical conductor in one second. Therefore, the unit ampere-hours, Ahr, equates directly to the quantity of electrical charge stored: 1Ahr is the same as 3600 coulombs of charge. The capacity of a cell or battery is related to the quantity of active materials in it, the amount of electrolyte, and the surface area of the plates. The capacity of a battery/cell is measured by discharging at a constant current until its terminal voltage is reached (typically about 1.75V for lead acid cells). This test is usually done at a constant temperature, under standard conditions of 25°C. The capacity is calculated by multiplying the discharge current value by the time required to reach the terminal voltage.

The term used to describe a battery's ability to deliver current is its rated capacity, specified in ampere-hours at a specific discharge rate. For example, a lead-acid battery rated for 200Ahr (for a 10-hour rate) will deliver 20A of current for 10 hours under standard temperature conditions, 25°C. Alternatively, a discharge rate may be specified by its charge-rate or C-rate, which is expressed as a multiple of the rated capacity of the cell or battery. For example, a battery may have a rating of 200Ahr at a C/10 discharge rate. The discharge rate is determined by the equation below:

$$\frac{C}{10} \text{ rate} = \frac{200\text{Ahr}}{10\text{hr}} = 20\text{A}$$

Battery capacity varies with the discharge rate. The higher the discharge rate, the lower the cell capacity. Fast charging or discharging can generate heat inside the battery that lowers its chemical efficiency, hence reduces its effective capacity. Lower discharge rates result in higher capacity, but very slow charging or discharging can also give lower effective capacity since all batteries suffer from internal self-discharging effects. Batteries are normally specified at several discharge rates (in amperes) along with the associated discharge time (in hours). The capacity of the battery for each of the discharge rates can be calculated as discussed above.

The lead-acid battery does not perform well at a 1C discharge rate (discharged in one hour). The rated capacity for lead-acid batteries is usually specified at 10 or 20-hour rates (C/10, C/20). UPS batteries are rated at 8-hour capacities and telecommunications batteries are rated at 10-hour capacities.

Peukert's Law relates battery capacity to discharge rate:

$$C_p = I^k t \quad (= xnF = nFM_r / \text{gram})$$

- where C_p is the amp-hour capacity at a 1A discharge rate
- I is the discharge current in Amperes
- t is the discharge time, in hours
- k is the Peukert coefficient, typically 1.1 to 1.3, dimensionless
- x is number of moles of reaction
- n is the number of electrons transferred per reaction mole
- F is Faraday's constant
- M_r is molecular mass

The coefficient k is 1.05 - 1.15 for AGM batteries, 1.1 - 1.25 for Gel, and 1.2 - 1.6 for Flooded Batteries.

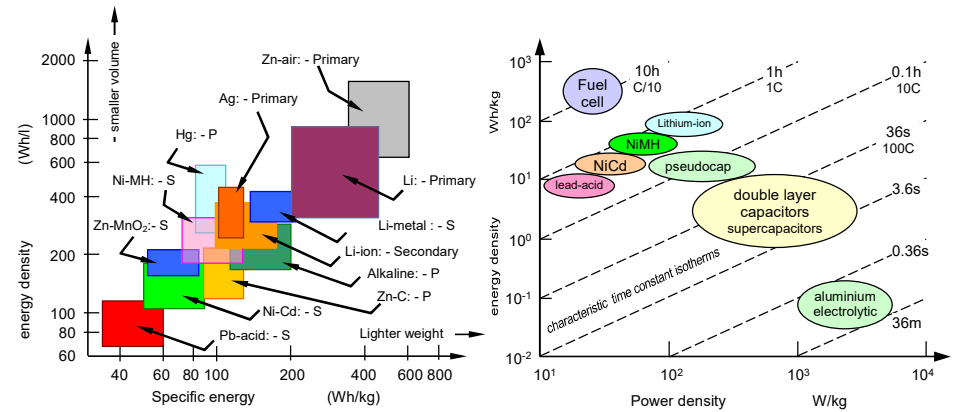

Figure 28.2. Gravimetric energy and power densities of different cell technologies.

Table 28.3b: Basic comparison of different battery characteristics and technologies

		Lead-acid	Nickel-cadmium	Re-chargeable Alkaline	Nickel-metal-hydride	Lithium-ion		
						LiCoO ₂	LiMn ₂ O ₄	LiFePO ₄
		sealed	sealed			cobalt	manganese	phosphate
gravimetric energy density	Wh/kg	30-50	45-70	80	60-120 250kJ/kg	150-190	100-135	90-120
volumetric energy density	Wh/L	60-90	60-150	220	140-300 360MJ/m ³	220-350	270	170
power density	W/kg	180	150	50	250-1000	760	1800	1400
cell voltage (theoretical)	V	2 (2.1)	1.25 (1.35)	1.5	1.25	3.6	3.7	3.3
internal resistance	mΩ/cell	20	30		40	100	50	35
load current	Peak, C Optimum Depth of discharge	5 0.2 80%	20 1 100%	½ < 0.2	5 0.5 80%	< 3 < 1 80%	> 40 < 10 80%	> 35 < 8 80%
operating temperature range	°C	-20 to 60	-40 to 60	0 to 65	-20 to 60	-20 to 60		
cycle lifetime	80% capacity	250	1500	< 25	400	300-500	400	> 1000
fast charge	hr	8	1	2-3	3	2	> 1	> 1
charge V limit	V	2.4	constant I		constant I	4.2	4.2	3.7
overcharge tolerance		high	moderate	moderate	low	low – no trickle charge tolerated		
self-discharge	%/month @ 20°C	2-5	15-20	0.3%	18-30	6-10		
maintenance	discharge to months	6	1V/cell 2	Not required	1V/cell 3	Not required		
cool storage	% charge top-up yr	100 ½	40 ½		40 ½	40 Not required		
safety		Thermally stable	Fuse Thermally stable		Fuse Thermally stable	Mandatory protection Stable to 150°C	Protection needed Stable to 150°C	Protection needed Stable to 150°C
electrolyte	liquid	H ₂ SO ₄ 4M	KOH 7M	KOH	KOH 6M	LiPF ₆ + solvent		
toxicity		Toxic lead and acid	Highly toxic	Low toxicity	Low toxicity, recyclable	Low toxicity		
cost	pu	low 0.6	low 1	low 0.5	medium 1.6	high 2		
commercialisation		1970	1950	1992	1990	1991	1996	2006
other features		Heavy Inexpensive Rugged	Long-life Durable Memory		Bulky High pressure	Low weight Low maintenance Needs temperature monitoring Needs over/under V and I protection		

28.4 The lead-acid battery

- Anode: Sponge metallic lead + Antimony, tin or calcium
- Cathode: Lead dioxide, PbO₂
- Electrolyte: Dilute aqueous sulphuric acid, H₂SO₄ (4.5 Mol)
- Applications: Motive power in cars, trucks, forklifts, construction equipment, recreational water craft, standby/backup systems
- Typical ratings: Specific energy density: 35 to 50 Wh/kg
Volumetric energy density: 60 to 70 Wh/l

28.4.1 Basic lead-acid cell theory

The traditional lead-acid battery is made up of flat plates, a lead anode, and a lead oxide cathode (various other elements are used to change density, hardness, porosity, etc.) suspended in a 35% sulphuric acid and 65% water solution. This solution is called electrolyte and causes a chemical reaction that produces electrons. A fibreglass separator between the plates prevents them from touching and short-circuiting.

The lead-acid battery discharge half-cell chemistry reactions shown in Table 28.4 (the reactions are reversed during charging).

Table 28.4: Half-cell electro-chemical (double sulphate) equations for the lead-acid cell

Location	Reaction (discharge)	55A-hr/kg	Potential
Anode Negative terminal	$Pb_{(s)} + HSO_4^-(aq) \rightarrow PbSO_4(s) + H^+(aq) + 2e^-$		$E_{-1/2cell}^- = -0.356V$
Cathode Positive terminal	$PbO_2(s) + HSO_4^-(aq) + 3H^+ + 2e^- \rightarrow PbSO_4(s) + 2H_2O$		$E_{+1/2cell}^+ = 1.685V$
Net REDOX reaction	$PbO_2(s) + Pb_{(s)} + 2H_2SO_4(aq) \rightarrow 2PbSO_4(s) + 2H_2O$		$E_{cell}^o = 2.041 V$

28.4.2 Cell/battery construction

The four key battery internal components shown in figure 28.3 are:

- Plates (grid and paste)
- Separator
- Electrolyte
- Vent (valve regulated)

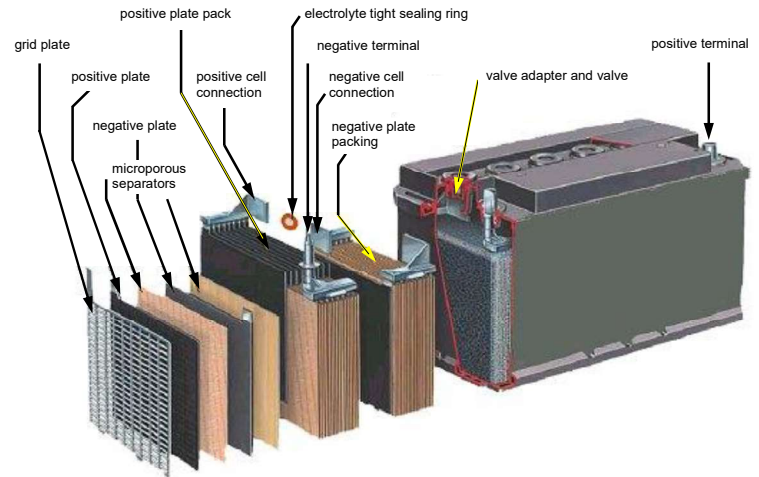

Figure 28.3. Cells used in the Lead Acid Battery. [Source Eurobat]

i. Plates

The plates and their grid structure that holds the active material have two functions:

- To provide mechanical support for the active material, which itself does not have the rigidity to be self-supporting.

- To act as a conductor to transmit current from all parts of the active material to the plate terminal. The ideal grid design should maintain a uniform current distribution throughout the active material. An uneven current distribution results in plate buckling during charge and heavy discharge cycles.

The ideal grid plate structure has the following characteristics:

- High conductivity
- High strength
- Corrosion resistance
- Compatibility with the active materials
- Manufacturability

Plate grid materials and characteristics

The plate grid structure in both pasted and tubular plate batteries is made from a lead alloy. A pure lead grid structure is not strong enough to stand vertically when supporting the active material. Other metals in small quantities are alloyed with lead for added strength and improved electrical properties.

The alloy used for plate grid frames varies:

- lead-antimony (<2% for hardening and resistance to corrosion);
- lead-calcium (for hardening) - along with Sn and Al additives, but free of antimony, to improve cyclability; and
- pure lead. Other alloys are also used for cyclability, such as tin, cadmium, and rare earths - selenium.

Lead-antimony cells are recommended for applications requiring long life under regular deep cycling regimes, discharging to depths greater than 20% of rated capacity, plus infrequent operation with a discharge depth as high as 50-60% of the 6-hour to 8-hour rated capacity.

Grids of lead calcium alloy or pure lead can also be cycled but repetitive cycles are restricted to a depth less than 20% of capacity plus infrequent operation with a discharge depth up to 50 to 60% of the 6-hour to 8-hour rated capacity.

Pure lead alloy plate types are used when low charged standing loss is required and occasional deep cycles are expected.

Lead-calcium and pure lead positive grids are used in standby applications when long periods of float are expected between power outages and discharge cycles, and where the average discharge depth is less than 20%. Pure lead designs offer better cycle life than lead-calcium, but poorer plate mechanical strength. During charging the cells are maintained at a constant charge voltage, and the charge current required to maintain lead-calcium and pure lead positive grid cells at voltage is much lower than for the lead-antimony grid. A reduction in float charge current reduces water loss and the maintenance cost of adding water to battery cells.

- Lead-antimony batteries can be deep cycled more times than lead-calcium batteries.
- Flooded lead-antimony batteries require more frequent maintenance as they near end-of-life since they use an increasing amount of water and require periodic equalization charges.
- Lead-calcium batteries have lower self-discharge rates as shown in figure 28.4 and therefore, draws less current while on float charge than lead-antimony batteries.
- Lead-calcium positive plates grow in length and width because of grid oxidation at the grain boundaries. This oxidation is usually caused by long-term overcharging, which is common to UPS and other batteries on constant-float charging. Grids may grow in size sufficiently to cause buckling or rupture of their containers.

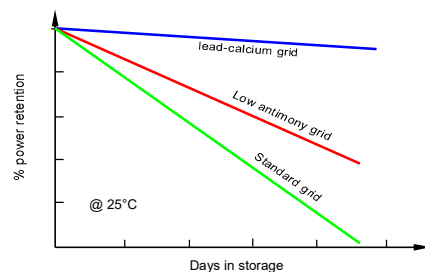

Figure 28.4. Self-discharge rates of different plate materials.

Lead-selenium (<2%) is the least common grid material. Lead-calcium (0.1% Ca plus ½% Sn) is a common **anode** grid material, but a lower cost alternative, lead-antimony (2 to 4% Sb), offers:

- lower internal heat and water losses,
- better mechanical strength, manufacturability,
- longer service life,
- easier to charge,
- lower cost,
- higher maintenance (water consumption increases dramatically at near end of life),
- higher discharge depths, but
- a high self-discharge rate of up to 5% per week, since antimony is reactive.

Lead acid batteries with electrodes modified by the addition of calcium providing the following advantages:

- More resistant to corrosion, overcharging, gassing, water usage, and self-discharge, all of which shorten battery life,
- Larger electrolyte reserve area above the plates,
- Higher Cold Cranking Amp ratings,
- Little or no maintenance, and
- Tin increases grid strength, improves manufacturability, and inhibits positive plate passivation.

Plate structures

Lead acid batteries have positive and negative electrode 'plates' and are classified by the type of positive plate (the negative plate is always the pasted lead flat plate type):

- Planté positive plate
- Manchex positive plate
- Tubular positive plate
- Pasted flat (positive, always negative) plate
- Rod (positive, always negative) plate

Negative plates in all lead-acid cells are formed from flat grid structures, pasted with pure lead as the electrical active material. A grid structure containing active material is termed a plate. The positive grid plate is pasted with porous lead dioxide. Both of these pastes are in a porous or spongy form to optimize surface area, thereby maximizing capacity.

(a) **Planté plate**:- The simplest lead-acid battery electrode is the *Planté plate*, which is a flat casted plate composed of pure lead that is attached to an antimony alloy lead connecting strap, as shown in figure 28.5. Since the capacity of a lead-acid battery is proportional to the electrode surface area exposed to the electrolyte, various methods are employed to increase electrode surface area per unit volume or weight. Planté plates are grooved, etched, striated, or perforated to increase the effective surface area. A typical Planté plate, which is only used as the positive electrode, is shown in figure 28.5. It offers good energy density and 100% capacity for its lifetime, which is determined by when less than 80% capacity is available.

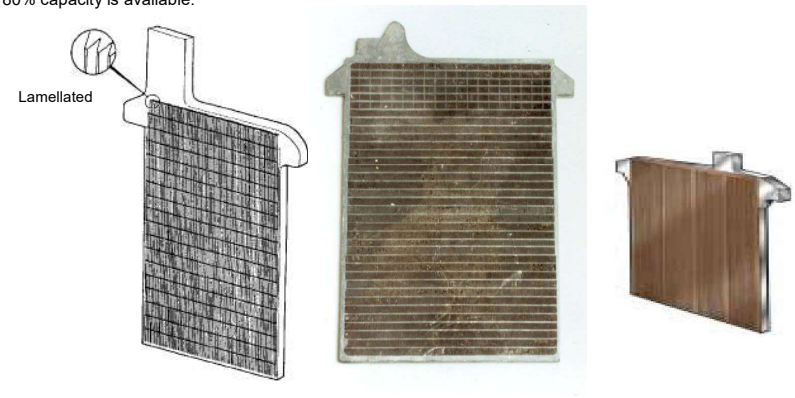

Figure 28.5. Planté grid structure and active paste filling.

(b) **Manchex (Manchester) plate**:- The *Manchex* type positive grid (or modified Planté plate) is casted with a low antimony, lead alloy. A button or rosette is a pure lead ribbon, which is serrated and rolled into a spiral form. These in turn are pressed or wedged into the holes of the grid. The surface of the buttons is oxidized to PbO_2 forming the positive active material. The grid is heavy and therefore gives long life, particularly in standby type service with moderate cycling such as railroad signal and utility application.

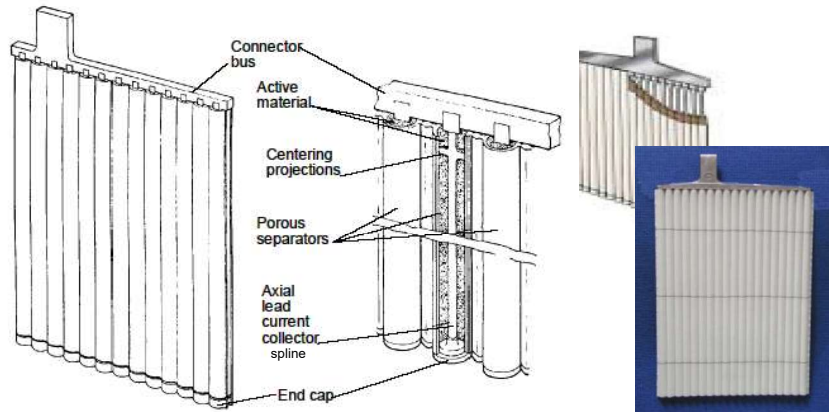

Figure 28.6. Tubular plate structure and paste filling.

(c) **Tubular positive plate**:- The tubular plate construction is shown in figure 28.6. The grid, which is the current conducting member, is a series of low antimony lead spines. Woven or porous plastic or glass material is used for the tubing, which is centred on each individual vertical spine. Then the active material is added and the ends are sealed. The tubular plate is only used as a positive electrode.

This type of battery is generally used in lift truck and material handling applications where deep cycling routines require an average discharge depth of 70 to 80 percent of the 6-hour rated capacity and recharge within an 8-hour period. Tubular positive plate batteries are also used for on-the-road diesel starting (motive power applications) and utility switchgear. In 20% depth, shallow cycling regimes, over 4,000 cycles can be obtained when multi-cycles per day are performed. It has excellent high charging characteristics, good standby life, and form a versatile cell type. Float life lasting up to 15 years is achieved. Tubular batteries are normally produced in one plate thickness. Variations in capacity are obtained by increasing the number of tubes per plate and/or by varying the tube (or plate) height.

(d) **Flat pasted plate**:- The pasted plate is the most common electrode for vented cells and can be used for both positive and negative plate structures. A typical pasted plate construction is shown in figure 28.7. The lattice grid is punched or cast with pure lead, lead-calcium, pure lead-tin or lead-antimony depending on the size of the plate and the application. Grid life is dependant on the grid alloy and plate thickness.

Active material, lead oxide PbO , is applied as a wet paste and the plate is then cured, dried and formed. The paste, or active material, is mounted into a frame or grid structure that mechanically supports it and serves as the electrical conductor carrying the current during both charge and discharge cycles. After the lead oxide paste has dried, the plates are immersed in a dilute sulphuric acid solution and current is passed through them, with opposite polarities for the positive and negative plates. The lead oxide (PbO) is converted to lead dioxide (PbO_2) in the positive plates and to lead (Pb) in the negative plates.

Glass mats and a perforated plastic retainer are wrapped around the positive plate to minimize the loss of positive active material and to obtain good cycle life. This wrap performs the same function as the retainer tube of tubular positive plates.

During the last stages of charge, oxygen gas is formed at the surface of positive plates. The agitation of gas bubbles streaming from the surface of exposed grids and active material tends to erode the active material, which is shed through the glass retainer and settles into the sediment space at the bottom of each cell. In light cycle or in float service, such positive active material shedding is not the major failure mechanism. In these applications, the glass mat retainer is lighter, thinner, and the perforated outer wrap is omitted.

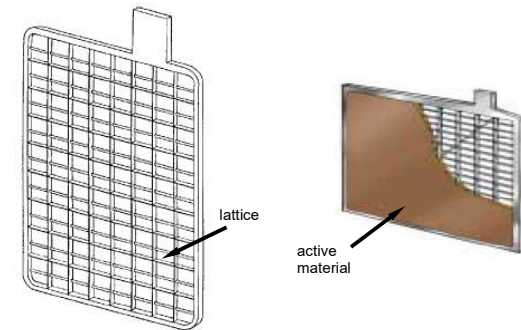

Figure 28.7. Pasted plate structure with paste filling (left: negative grid, right: positive grid).

Such designs depend upon a ribbed microporous separator adjacent the negative plate to achieve longest life. Pasted plates have good energy density and are made with thin (1mm) or thick (7mm) grids depending on the application, which are mainly automotive and standby. When the application demands a high ampere rate for a short time, many thin plates are used. Thicker plates with fewer plates per cell are used for applications with a low ampere drain for long periods of time. In general, for a given service condition, thin plates result in a shorter life than thick plates.

(e) **Rod plate**:- The rod plate electrode shown in figure 28.8 can form either positive or negative electrodes. Robust rod plate electrodes use a lead antimony or lead-calcium cast grid, resulting in a moderate energy density. They are mainly used for standby applications and yield a 12 to 20 year life.

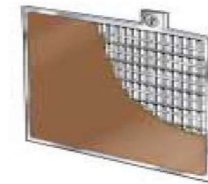

Figure 28.8. Rod plate structure with paste filling.

ii. Expanders

The chemical reaction of the lead-acid battery depends, in part, on how well the sulphuric acid in the electrolyte can react with the lead in the positive and negative plates. An expander is added to the active material in each plate to facilitate electrolyte diffusion into the plate. It is generally a mixture of an organic compound, typically lignin or a lignin derivative such as barium sulphate and carbon black.

As the ratio of expander-to-active material is increased, the electrolyte's ability to make contact with all of the active material improves. Longer-life cells typically have thick plates to better withstand the unavoidable corrosion process; expanders help the electrolyte reach the interior of thicker plates.

With too much expander added to the plate, the active material tends to dissolve into the electrolyte, destroying the cell. Too little expander has the effect of reducing the cell's capacity because the electrolyte is restricted in its ability to enter the interior active material in the plate. The addition of the expander to the active material is another variable that has to be controlled during the manufacturing.

iii. Separators and Retainers

Separators are installed between the plates to prevent them from touching and shorting. A separator is constructed of a highly porous, nonconductive, inert material (non-woven glass fibre cloth, sintered PVC, or PVC/polyethylene) that allows conduction of electrolyte ions between the plates. The ideal separator has the following characteristics:

- As thin as possible so that it does not add volume to the cell
- As stiff as possible to hold its position throughout the cell's life
- Highly porous to allow electrolyte diffusion throughout the cell and to reduce the internal resistance
- Small pore size to prevent electrical shorts between the plates
- Puncture resistant so that dendrites and plate imperfections do not damage it
- Nonconductive, so as not to contribute to plate self-discharge
- Electrochemically compatible with the acid and lead environment (heat and oxidation resistance)
- Electrical low resistance to minimize effect on cell voltage
- Manufacturability and inexpensive

A retainer is a porous mat of inert material, such as fibreglass, that is either pressed between the plates or wrapped around the positive plate. Repeated charge and discharge cycles tend to cause shedding of active material from the plate surface. The retainer helps keep the active material in position on the plates. The separator might also have ridges to ensure compression of the retainer against the plates.

iv. Electrolyte

Dilute sulphuric acid H_2SO_4 is used as the medium for conducting ions in the electrochemical reaction in the battery. Sulphuric acid is highly reactive and ionizes almost completely in water. The ions are in constant motion, attracted or repelled by one another. This constant random motion tends to cause the ions to diffuse throughout the electrolyte. The diffusion process is not immediate and can take a relatively long time to reach equilibrium throughout the electrolyte.

Sulphuric acid electrolyte has a specific gravity of 1.320 at 25°C (water has a specific gravity of 1.0).

Absorbent Glass Mat (AGM) Separator

Micro porous non-woven fibreglass (silica) cloth acts as both a separator prevent shorting between positive and negative plates and an electrolyte absorber (by capillary action). The cloth has a high heat and oxidation resistance and high porosity offers excellent electrolyte absorption and retaining ability, as well as excellent ion conductivity, compressibility, puncture resistance and electrical resistance, with high heat and oxidation resistance. The blend of glass micro fibres having an optimum ratio of fine and extra fine fibre sizes which is chemically stable, inert, to lead oxide and in the dilute sulphuric acid electrolyte, is immobilized. This blend features superior wicking characteristics and promotes maximum electrolyte retention. The flexible and resilient AGM layer is squeezed to an optimum compression level during assembly to provide sufficient long-term contact with the plate surface, thus prolonging the battery cyclic life. This compression also promotes retention of the active material if the battery is exposed to shock or vibration conditions. Since the plates are completely wrapped by the separator and the electrolyte is totally absorbed in the separator and plates, shedding of active material, which can cause shorting and reduced battery safety with flooded batteries, is avoided.

The AGM also allows oxygen diffusion from the positive plate for the oxygen recombination cycle at the negative plate.

The AGM electrolyte contains high purity sulphuric acid and demineralised, deionised water to increase battery performance. Since the designs are 'acid-starved', between 90 and 95 percent - but not fully, saturated, to protect the plates from deep discharge, the acid concentration can drop to near zero during an extremely deep discharge. Substances that will not dissolve in acid may become soluble when the concentration drops this low. Upon recharge, these dissolved substances crystallize out of the electrolyte, potentially destroying the battery. The electrolyte prevents these possibilities.

The AGM separator can be enveloped with a thin layer of microporous polyethylene which is wrapped around the glass-matted plate and then sealed along the sides to eliminate the possibility of shorts at the edges of the plate (a common failure mode). The microporous polyethylene is more durable and puncture resistant than the AGM material alone and significantly reduces the occurrence of plate-to-plate shorts.

Gel electrolytes

Gelled electrolyte contains sulphuric acid, fumed silica, pure demineralised, deionised water, and a phosphoric acid additive. The phosphoric acid is key to batteries delivering a long cycle life.

A gel glass mat, with double insulating separators is also used.

- The fibreglass mats embed into the surface of the plates, reinforcing the plates and lock the active material onto the plate for longer life and extended performance.
- The clean separators have no oil contamination or other impurities, therefore, resistance is low and battery performance is high.
- Excellent porosity allows maximum charge flow, which means better power-per-kg.
- Superior resistance to oxidation reduces separator failure, which extends life.

The AGM and gelled electrolyte battery designs have common components such as containers, plates, and pressure relief valves, but they have different separator and electrolyte immobilization systems. Consequently, the gelled design can have a greater electrolyte reserve than the AGM cell and is usually better suited to long duration applications. A gelled electrolyte cell is typically heavier and larger than an absorbed electrolyte cell for a given capacity.

v. Pressure relief safety valve

Each cell in the VRLA battery has a pressure relief safety valve, to prevent case bursting, where the sealing material is neoprene rubber. The normally closed valve is designed to release excess gasses that may abnormally build up over time having not recombined inside of the battery, resulting from overcharging, high operating temperatures or misuse. Once the pressure is vented, the valve instantly automatically re-seals. This valve function is repeatable, whenever venting is required. The oxygen and some hydrogen gasses that escape, rapidly disperse into the atmosphere. Hydrogen can ignite at concentrations as low as 4% in air. The one-way valve also ensures that no air gets into the battery since the oxygen would react with the negative plates causing internal discharge. The pressure relief valve design accomplishes the following functions:

- Limits the maximum internal pressure of the cell
- Maintains a minimum internal pressure to promote recombination and minimize water loss
- Prevents atmospheric oxygen from entering the cell and discharging the negative plates

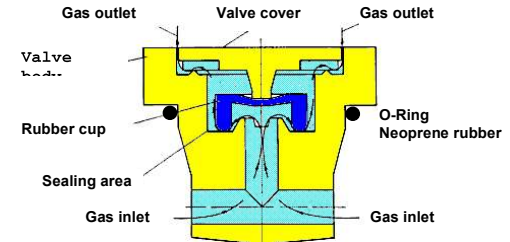

Figure 28.9. Valve system for sealed batteries.

Due to an oxygen recombination efficiency of about 99%, the battery barely loses electrolyte and requires no addition of distilled water throughout its service life.

Both AGM and Gel cells employ a self-resealing, spark arresting, venting valve. The labyrinth system construction of the valve avoids any outside spark or fluid from penetrating into the battery via the valve. The principle of the valve used for VRLA-batteries is shown in figure 28.9, along with its adapter, which depends on the battery type.

The valves operate with the following pressures, p :

Opening: $0.180 \geq p \geq 0.06 \text{ bar}$: 1 to 6 psi (7 to 44kPa, 0.07 to 0.44 bar)

Closing: $0.155 \geq p \geq 0.03 \text{ bar}$

vi. Cases

The moulded battery case, with cell dividers is ideally formed from flame retardant, non-conductive, translucent ABS (or PVC, polycarbonate, polystyrene, styrene-acrylonitrile) plastic resin and epoxy resin (or ultrasonic or heat) sealed, both materials being acid resistant.

28.4.3 Characteristics of the flooded lead acid cell

i. The chemistry of discharge

During discharge, both the PbO_2 (lead dioxide) of the positive plate and the Pb (spongy lead) of the negative plate are converted into $PbSO_4$ (lead sulphate), whilst sulphuric acid H_2SO_4 in the electrolyte is consumed. Specifically, lead dioxide (positive plate) and lead (negative plate) react with sulphuric acid to create lead sulphate, water, and energy. This electrochemical reaction causes a reduction of the specific weight of the electrolyte, as the sulphuric acid contained in the electrolyte passes into the plates during discharge. These two plate processes, during discharging, are shown in figures 28.10 and 28.11a.

These processes are reversed during the charging phase.

The lead-acid battery performs best at a slow 24-hour discharge. Pulsed discharge is also effective because the intervening non-discharge periods allow dispersion of the depleted acid back into the electrode plate. A discharge at 1C of the rated capacity (Ah for 1 hour) yields the poorest efficiency. The lower level of conversion, or increased polarization, manifests itself in a momentary higher internal resistance due to the depletion of active material in the reaction.

The lead-acid battery has a relative low energy density, making it unsuitable for portable devices. In addition, the performance (both charging and discharging) at low temperatures is marginal.

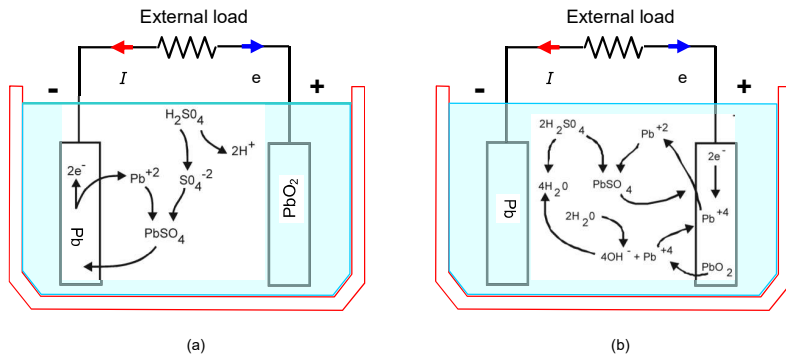

Figure 28.10. Lead acid battery plate discharge reaction: (a) negative plate and (b) positive plate.

ii. The chemistry of charge

During the charging phase, shown in figure 28.11b, which is the reverse of the discharge phase, the PbSO₄ (lead sulphate) of the positive plate oxidizes and reforms as PbO₂, while in the negative plate, the PbSO₄ (lead sulphate) re-forms as Pb (spongy lead). That is, the lead sulphate and water are electro-chemically converted to lead, lead oxide, and sulphuric acid by the external charging source. The general formula in Table 28.4, concerning the transformations occurring during charge/discharge phases, correspond to an electric quantity of 2F (Farads) or 53.6 Ahr (Ampere-hour). For a discharge reaction to occur, active materials are required in the ratio of 239.2 grams of PbO₂, 207.2 grams of Pb, and 196.2 grams of H₂SO₄. The same weight ratio holds for the charge reaction.

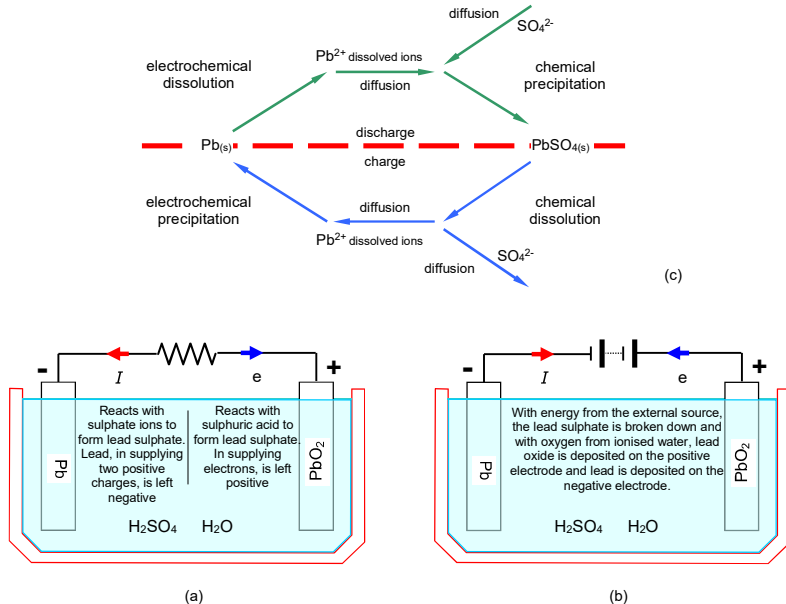

Figure 28.11. Lead acid battery plate reaction when being: (a) discharged, (b) charged, and (c) charge/discharge processes in the lead negative anode.

The lead-acid cell does not lend itself to fast charging, with a typical charge time of over 8 hours. A periodic fully saturated charge is essential to prevent sulphation and the battery must always be stored in a fully charged state. Leaving the battery in a discharged condition causes sulphation and a recharge may not be possible.

Finding the ideal charge voltage limit is critical. A voltage above 2.40V/cell produces good battery performance but shortens the service life due to grid corrosion of the positive lead plate, as shown by the cathode chemical equation in Table 28.6. A low voltage limit is subject to sulphation on the negative plate. Leaving the battery on float charge for a prolonged time does not cause damage.

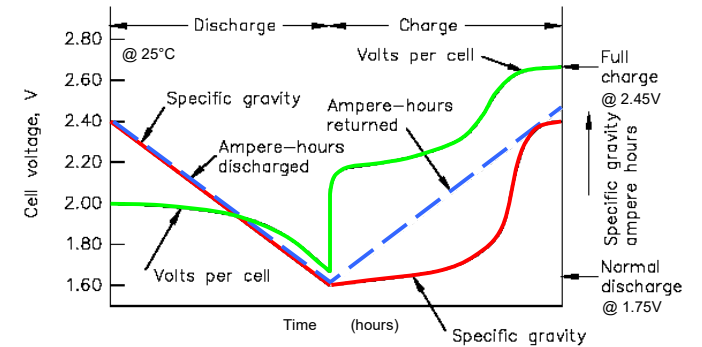

Figure 28.12. Electrolyte specific gravity of a lead acid cell during discharge, then charging.

iii. Specific Gravity of a battery

When testing a non-sealed (flooded) battery with a hydrometer, it is the amount of sulphuric acid in the electrolyte that is being measured. A low specific gravity reading means that the chemistry that makes electrons is deficient. A sulphate (from the acid electrolyte) is deposited on the battery plates when discharging but recharging the battery returns the sulphate to the electrolyte. During discharge, the specific gravity decreases linearly with the ampere-hours discharged as indicated in figure 28.12. It increases during recharging. Specific gravity, which decreases with temperature, is thus used as an indicator of the state of charge of a cell, not its energy capacity.

The negatively sloping specific gravity line during discharge is approximated by [acid% = 90 x (SG - 1)]:

$$\text{Specific gravity} = \text{cell open-circuit voltage} - 0.845$$

or

$$\text{Cell open circuit voltage} = \text{specific gravity} + 0.845 = 1.11 \times \text{acid\%} + 1.845.$$

A specific gravity range of 1.210 (19% acid) to 1.240 (21% acid) is usual for vented cells (at 25°C). VRLA batteries commonly use electrolyte with a lower specific gravity of 1.250 (22% H₂SO₄ acid to 78% water) to 1.300 (27% acid) to compensate for the smaller quantity of electrolyte.

When selecting a battery for a specific application, the effects of operating with a high or low specific gravity to be considered are:

Higher specific gravity	Lower specific gravity
Higher capacity	Lower capacity
Shorter life	Longer life
Less space required	More space required
Higher pulsed discharge rates	Lower pulsed discharge rates
Less adaptable to 'floating' operation	More adaptable to 'floating' operation
Higher standing loss	Lower standing loss

Specific gravity measurements should be taken 72 hours after an equalizing charge and the subsequent float charge.

iv. Cycling: Lead-acid does not like deep cycling. A full discharge decreases battery service life. This deterioration characteristic also applies to other battery chemistries in varying degrees. To prevent the battery from being stressed through repetitive deep discharge, a heavier battery (higher Ahr rating) should be used. Lead-acid technology is inexpensive but the operational costs can be higher than a nickel-based system if repetitive full cycles are required.

Depending on the depth of discharge and operating temperature, the valve regulated lead-acid cell provides 200 to 300 discharge/charge cycles. The primary reasons for this relatively short cycle life are:

- positive electrode grid corrosion;
- active material depletion; and
- positive plate expansion.

These deteriorating changes are more prevalent at higher operating temperatures. The optimum operating temperature for a lead-acid battery is 25°C with higher temperatures reducing longevity. As a guideline, every 8°C temperature rise halves remaining battery life. Cycling does not prevent or reverse the deteriorating trend.

v. Self-discharge: Self-discharge of a flooded cell is about 40%/year, which is low for rechargeable batteries. In comparison, nickel-cadmium self-discharges the same amount in three months.

vi. Flooded cell plates: Sulphation occurs on the negative **anode** lead plate if the battery is left in a partially or fully discharged state. Due to self-discharge, large, non-conducting sulphate crystals with a low surface area, build-up and block effective recharging conduction paths. With a density of 6.287gm/cm³, the sulphate occupies a larger volume than the original paste, hence the plates deform under the stress associated with the increased volume.

The **cathode** is lead oxidised to 80% lead oxide, with red lead, Pb₂O₄, for better conductivity. The oxide is mixed with H₂SO₄, grid pressed, and cured to form a cohesive porous solid. The service life of a lead-acid battery can generally be measured by the thickness of the positive cathode lead plates. The thicker the plates, the longer the remaining life. Thus the weight of a battery is an indication of the lead content hence life expectancy. During charging and discharging, lead on the plates is gradually consumed and sediment falls to the bottom of the cell. Higher temperature, typically over 60°C and/or an uncharged state, accelerate corrosion of the lead oxide positive plate.

The plates of automotive starter batteries are about 1mm thick, while the typical golf cart battery will have plates 1.8 to 2.8mm thick. Forklift and traction batteries have plates that exceed 6mm. Most industrial flooded deep-cycle batteries use lead-antimony plates that improve plate life at the expense of increased gassing and water loss.

vii. Disposal: The high lead content makes the lead-acid battery environmentally unfriendly, although the materials are recyclable by furnace heat treatment, which recovers the metals.

28.4.4 Different lead-acid cell and battery arrangements

Three lead-acid systems, valve-regulated based, have emerged in an attempt to immobilise or stabilise the electrolyte:

- the larger Valve-Regulated-Lead-Acid (VRLA) cell, based on the flooded cell,
- the smaller **GEL cell** (mistakenly referred to as Sealed Lead-Acid (SLA) cell), and
- the newer absorbed glass matt (AGM) cell.

Batteries based on these cells are similar and are designed with a low over-voltage potential to prevent the battery from reaching its gas-generating potential during charge since excess charging causes gassing and water depletion. Consequently, they are never charged to their full capacity. To reduce dry-out, sealed lead-acid batteries use lead-calcium instead of the lead-antimony anode plates.

The sealed lead-acid battery is typically rated at 5-hour @ 0.2C and 20-hour @ 0.05C discharges. Longer discharge times realise higher capacity because of lower losses. The lead-acid cell performs well on high load currents but not deep discharge.

The **gel cell lead-acid battery** is a 'sealed' maintenance-free battery that operates in any position. The liquid electrolyte is gelled into moistened separators and the enclosure is sealed. A safety valve allows venting during charge and atmospheric pressure changes.

The **Absorbed Glass Mat Battery (AGM)** is a newer type of 'sealed' lead-acid battery that uses absorbed glass mats between the plates. It is sealed, durable, maintenance-free, and the sturdy plates are compressed and rigidly mounted to withstand shock and vibration. AGM batteries recombine 99% of the oxygen and hydrogen, so there is virtually no water loss.

Table 28.5: Comparison of valve-regulated lead acid battery types

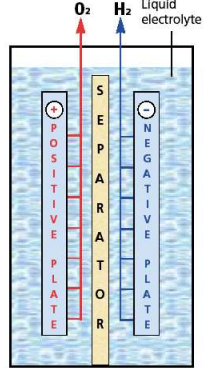
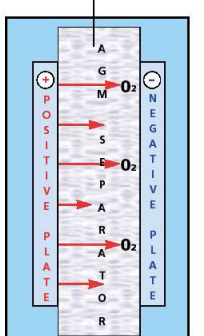
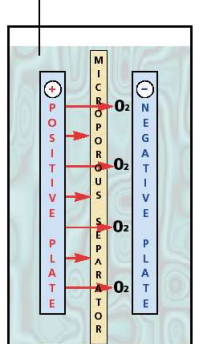
VALVE REGULATED LEAD ACID BATTERIES: GAS RECOMBINATION	<p>When a charge current flows through a fully charged conventional lead acid cell, electrolysis of water occurs producing hydrogen from the negative plate and oxygen from the positive plate. This results in electrolyte water loss from the cell and regular topping-up is needed.</p> <p>However, the evolution of oxygen and hydrogen gases does not occur simultaneously, because the efficiency of recharge of the positive plate is not as good as the negative plate. This means that during charging, oxygen is generated at the positive plate before hydrogen is evolved from the negative plate.</p> <p>At the same time that oxygen is generated from the positive plate, a substantial amount of highly active spongy lead exists on the negative plate before it commences hydrogen evolution. Therefore, provided oxygen can be transported to the negative plate, conditions are ideal for a rapid reaction between lead and oxygen: that is, the oxygen is electro-chemically reduced on the negative plate according to $2e + 2H+ + \frac{1}{2}O_2 \rightarrow H_2O$, where the final product is water. The external current flowing through the negative plate drives this reaction instead of hydrogen generation that would occur in a flooded cell. This process is called gas recombination.</p> <p>If the process were 100% efficient, no water would be lost from the cell. By careful design of the cell constituents, gas recombination of more than 95% is achieved. An efficient gas recombination cell can be made using either Absorbent Glass Mat (AGM) separators or gelled (gel) electrolyte.</p>	 <p>Conventional Cell</p>
ABSORPTIVE GLASS MAT (AGM)	<p>To achieve a high gas recombination efficiency it is necessary to create gas diffusion paths between the positive and negative plates. Then oxygen can migrate from the positive to the negative plate where it reacts with the spongy lead negative active material.</p> <p>In the AGM cell, a special, highly porous micro-fibre glass separator is used. By controlling the saturation level and the exact balance between electrolyte quantity and porosity, a continuous path for oxygen transport is formed. Optimum conditions for gas recombination achieve an efficiency of better than 99%.</p> <p>The special separator used in this battery produces a low resistance, making it good for delivering high currents.</p> <p>The VRLA AGM battery can be used for all discharge rates from switch closing/tripping and engine starting which requires short duration high currents, to telecom and navigational systems requiring long, stable power occasionally for many days.</p>	 <p>AGM Cell</p>
GELLED ELECTROLYTE (GEL)	<p>For gelled electrolyte cells, a mixture of sulphuric acid with finely dispersed silica is used to produce a gel. By vigorously stirring, the thixotropic mixture stays fluid so that it can be poured into the cells. The mixture then stiffens and forms a firm gel. As the gel stiffens, it shrinks and this leads to the formation of numerous micro-fine cracks through which the oxygen generated at the positive plate can diffuse to the negative plate.</p> <p>Because a conventional microporous separator is used in the gelled electrolyte cell, the internal resistance of such cells is slightly higher than AGM equivalents. Therefore Gel cells are better suited to medium and long rate discharges.</p> <p>Tubular plate cells with gelled electrolyte are suitable for cyclic applications or where there is a need to supply power to equipment for several hours. The rod plate offers a compromise between tubular plate and pasted plate types by giving a higher power to weight and volume ratio than the tubular type but being more robust than the pasted type because the design is more corrosion resistant.</p>	 <p>GEL Cell</p>

The charging voltages are the same as for other lead-acid batteries. Even under severe overcharge conditions, hydrogen emission is below 4%. The low self-discharge of 1 to 3% per month allows long storage before recharging. The AGM costs twice that of flooded batteries of the same capacity. The high-density packing and other cell features give the AGM battery a low internal resistance, therein allowing fast recharging. This low resistance means AGM batteries tend to stay cooler during heavy charging and discharging and maintain a higher terminal voltage under heavy loads.

The three main valve-regulated lead acid battery types are summarized and characterised in Table 28.5.

In the composite **carbon-graphite foam grid battery** the lead metal negative grids found in the conventional lead acid battery are replaced with lightweight carbon-graphite foam, which offers a higher energy density. The high chemical interface surface area of the carbon-graphite foam allows for greater electron flow from the battery's chemistry, and is highly resistant to sulphation, which is a common lead-acid battery failure mode. The foam is not reactive in the lead-acid environment, so does not corrode and the graphite offers better thermal conduction properties than lead. A constraint to lead-acid battery chemistry is the bounded reactive interface area between the active chemistry and the electrodes. The replacement of both the negative and positive battery plate grids with stable carbon-graphite foam grid material attempts to redress this active area constraint.

The bipolar lead-acid battery

Virtually all lead-acid batteries are monopolar where a large number of plates are stacked in each cell, increasing the capacity of the battery, and cells are serially coupled to increase voltage. Since the current in a monopolar battery flows from one end of the battery to other, high currents will be unevenly distributed over the electrodes with maximum current flowing close to the posts, as shown in figure 28.13a.

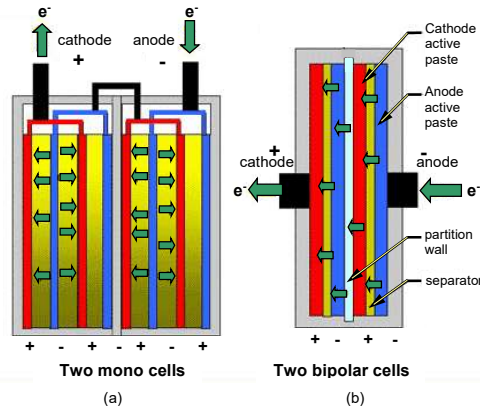

Figure 28.13. Construction of lead-acid batteries: (a) conventional cells and (b) bipolar cells.

A bipolar lead-acid battery is made up of a stack of series coupled bipolar electrodes. Each bipolar electrode, except the end ones, has one side of an electrical conducting partitioning wall covered with porous lead, which is the negative side of the bipolar electrode, and the other side - the positive side, covered with porous lead dioxide. Since current must pass through the end electrodes, it will flow perpendicular to all electrode surfaces, also at high currents, and the active materials are efficiently utilized with minimal internal resistance.

Lead-infused ceramic plates are coated with a positive paste on one side and a negative paste on the other. The plates are then stacked on top of each other with a separator between them, thus forming a battery in a bipolar design, as shown in figures 28.13b and 28.14. The partitioning walls are porous, lead-infiltrated ceramic plates. The bipolar plates have high corrosion resistance, and the lead surface on the bipolar plate enables good contact to the active material in the same way as standard lead acid technology. The battery contains only half the amount of lead per unit of output and offers 800W/kg discharge and 400W/kg recharge.

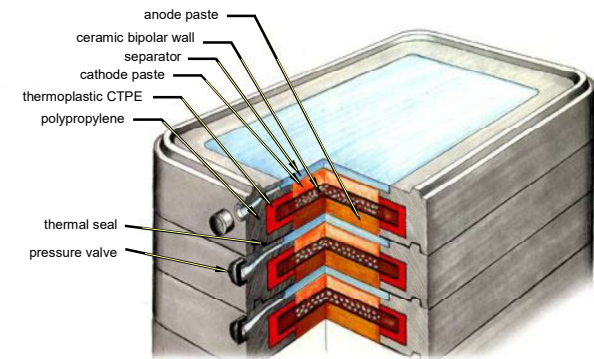

Figure 28.14. Construction of the bipolar lead-acid battery.

28.4.5 Lead acid battery charging and storage regimes

The charge algorithm for lead acid batteries differs from nickel-based chemistry in that voltage limiting rather than current limiting is used and VRLAs cannot be fully charged as quickly as nickel-based cells. Charge time of a valve-regulated lead acid (VRLA) cell is 12 to 16 hours, as shown in figure 28.15. With higher charge currents and multi-stage charge methods, the charge time can be reduced to less than 10 hours. A multi-stage charger applies a constant-current charge, then a topping charge, and finally a float charge. During the constant current charge period, the battery charges to 70 percent in about five hours; the remaining 30 percent is completed by a slow topping charge for a further five hours and is essential for battery long lifetime. If the battery is not completely saturated, the VRLA cell will eventually lose its ability to accept a full charge and battery performance deteriorates. The third stage is the long-term float charge, which compensates for the self-discharge after the battery has been fully charged.

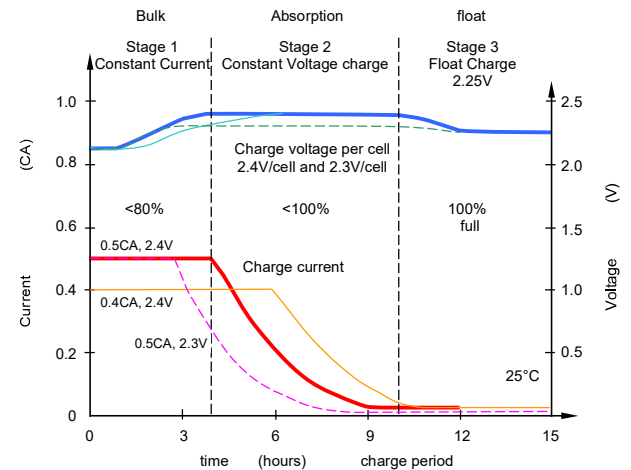

Figure 28.15. Charge stages of a lead acid battery; constant-current charge, topping charge, and float charge.

The cell-voltage limit is critical and typical voltage limits are from 2.30V to 2.45V. If a slow charge is acceptable, or the room temperature may exceed 30°C, the voltage limit is 2.35V/cell. If a faster charge is required, and the room temperature will remain below 30°C, 2.40V to 2.45V/cell is used. The charge voltage limit is a momentary voltage peak and the battery cannot dwell at that level. This voltage crest is only used when applying a full charge cycle to a battery that has been discharged. Once fully charged, a float charge is applied, which is a constant, lower voltage level. The float charge voltage of low-pressure lead acid cells is between 2.25 to 2.30V/cell and the optimal float charge voltage is temperature dependant. A higher temperature demands slightly lower voltages and a lower temperature demands higher voltages. Chargers with temperature sensors can optimize the float voltage.

Float charge techniques attempt to fully charge the cell to avoid sulphation on the negative plate, but cannot over-saturate the cell, which causes grid corrosion on the positive plate. In addition to grid corrosion, a high float charge contributes to loss of electrolyte. Cell ageing variations result in differing optimum float charge voltages. The development of gas pockets within some cells over time causes hydrogen evolution from overcharging. Other cells undergo oxygen recombination in an almost starved state. Since battery cells are connected in series, controlling the individual cell voltages during charge is not possible. If the applied cell voltage is too high or too low, a weaker cell deteriorates further, becoming more pronounced with time. Individual cell-balancing devices can correct some of these problems if access to each cell is possible.

A ripple voltage imposed on the charge voltage causes problems for lead acid batteries, especially larger VRLA batteries. The peak of the ripple voltage constitutes an overcharge, causing hydrogen evolution; the troughs induce a brief discharge causing a starved state. Electrolyte depletion may result. Pulse-charging lead acid batteries reduces cell corrosion, but is a debated non-conclusive subject. Non-optimal battery voltage thresholds cause a gradual decrease in capacity due to sulphation. The pressure relief valve allows some recombination of the gases during charge. A VRLA must be stored in a charged state. A topping charge should be applied every six months to avoid the voltage from dropping below 2.10V/cell.

By measuring the open cell voltage while in storage, an approximate charge-level indication can be obtained, as indicated in figure 28.22. A voltage of 2.11V, if measured at 25°C, indicates that the cell has a charge of 60 percent and higher. If the voltage is at or above this threshold, the battery is in good condition and only needs a full charge cycle prior to use. If the voltage drops below 2.10V, several discharge/charge cycles may be required to bring the battery to full performance. When measuring the terminal voltage of any cell, the storage temperature should be observed. A cool battery raises the voltage slightly and a warm one lowers it.

When charging a new lead acid battery with over-voltage, current limiting must be applied once the battery starts to draw full current. If a battery does not accept a normal charge after 24 hours under elevated voltage, a return to a normal condition is unlikely.

During prolonged float charge, a periodic topping charge, also known as an 'equalizing charge', is recommended to fully charge the plates and prevent sulphation. An equalizing charge raises the battery voltage for several hours to a voltage level above that specified. Loss of electrolyte through elevated temperature may occur if the equalizing charge is not controlled correctly. Because no liquid can be added to the VRLA cells, a reduction of the electrolyte causes irreversible damage.

Some exercise, or brief periodic discharge, is believed to prolong battery life of lead acid cells. If applied once a month as part of an exercising program, the depth of discharge should only be about 10 percent of the total capacity. A full deep discharge regular maintenance cycle decreases battery service life. Disconnecting the float charge while the VRLA is on standby is another method of prolonging battery life. Occasionally a topping charge is applied to replenish the energy lost through self-discharge. This lowers cell corrosion and prolongs battery life. Essentially the battery is maintained as if it was in storage. This is only applicable to applications that do not draw a load current during standby. In many applications, the battery acts as an energy buffer, thus needs to be under continuous charge.

Thermal runaway phenomenon

Thermal runaway is an abnormal phenomenon occurring during charging, which manifests as a distended battery. A warmer battery requires a reduced charging voltage. Thermal runaway means a state of operation where heat generation increases faster than heat dissipation, which results during severe overcharging or electrolyte dry-out. The result is an increase in battery temperature. At elevated temperature, the internal oxygen cycle is accelerated, and the developed heat causes a further increase in battery temperature. With this self-sustaining cycle, thermal runaway results, and the battery becomes physically deformed and bloated. Several precautions can avoid thermal runaway:

- Avoid battery dry-out: Do not charge at voltages higher than the gassing voltage (2.4V/cell) for too long a duration, for example, >12 hours.
- Any defective battery, for example, the short-circuited or aged battery, in a string of batteries should be removed to prevent overcharging of other batteries.
- The internal oxygen cycle reaction usually occurs in the overcharging stage, where the originally decreasing current density in the constant-voltage-charging mode may increase. If the charger

cut-off condition is too low when the battery is aged, the charger overcharges the battery until thermal runaway results.

Gel batteries are much less susceptible to thermal runaway than AGM batteries. Batteries may become more susceptible with increasing age. Without a recombination reaction, flooded batteries convert most excess charging energy to gas, not heat, making them virtually immune to thermal runaway.

28.4.6 Valve-regulated battery discharge characteristics

i. Battery discharge characteristics

Through a series of discharge tests as in figure 2.16, curves can describe the expected cell capacity as a function of discharge rate and minimum allowed cell voltage. Figure 28.17 shows a typical set of battery discharge characteristic curves illustrating the effect of discharge rate on battery capacity. The minimum voltage, the discharge time, and the discharge rate are interrelated.

The discharge curves in figure 28.17 have several straight time lines (8hr, 5hr, and so on down to 1min) coloured green, radiating from the origin, with a series of voltage lines (1.75V, 1.80V, and so on up to 1.9V) shown coloured blue, intersecting the green straight time lines. The x-axis and y-axis have coordinates amperes per positive plate and ampere-hours per positive plate, respectively. A separate line, labelled the initial volts line, is shown in red at the top, with its reference y-axis, in volts, on the right. The inter-relation of these lines defines the cell's expected capability as a function of discharge rate and duration.

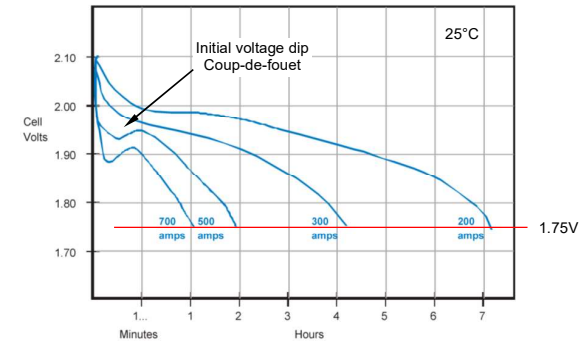

Figure 28.16. Cell voltage during discharge with a 1.75V/cell end voltage.

These curves are based on a specific cell size tested at a constant current discharge with a series of different discharge rates. Each tested cell initially has 100% capacity and characterisation is at the 25°C reference temperature. The total energy removed from the cell can be calculated from the constant current discharge rate and the discharge time, $E = I_{dis} \times t$.

Data is presented based either on the cell size or on the number of positive plates. Information on a per plate basis provides a common reference for a range of cell sizes in a family. Stationary cells typically have n positive plates and $n+1$ negative plates. If data is presented in terms of the number of positive plates, then the rating of a particular cell size is the rating of a single positive plate times the number of positive plates, n .

There are 10 positive plates in the cell characterised in figure 28.16. The test discharge currents are divided by 10 to obtain the current per positive plate. The ampere-hours are calculated based on the discharge rate and the time to reach the specified end voltage limit, 1.75V in figure 28.16.

For any discharge rate, the cell voltage immediately falls to an initial cell voltage level, which decreases as the discharge rate increases. If the discharge rate is too high, the cell voltage will immediately fall to the defined end-point voltage, which sets the discharge limit for the defined end-point voltage.

The data is transposed onto a graph with x-coordinates of amperes per positive plate and y-coordinates of ampere-hours per positive plate. This shows the discharge capability of a single positive plate cell to a particular final voltage. The upper blue line in figure 28.17 shows the data graphed for a 1.75V final voltage. This line shows the relationship between amperes and ampere-hours for this plate. The initial volts line is drawn based on the observed initial voltage upon application of each discharge rate.

The 1.75V line shows the rate (amperes) and how much energy (ampere-hours) can be removed before the cell voltage falls to 1.75V. The process is repeated for each voltage level to create the family of capability curves shown in blue in figure 28.17.

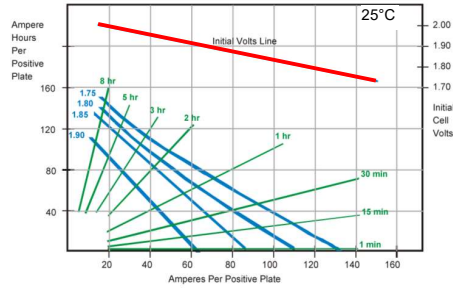

Figure 28.17. Typical battery discharge characteristics.

Next, the green radiating time lines are added to the plot. These time lines show how long the cell plate can provide a certain discharge rate before the voltage falls to the specified level. These green straight lines radiate radially from the origin and are based on how long it takes at a given discharge rate to remove a certain amount of energy (ampere-hours) from the positive plate.

For example, it takes 8 hours to remove 160Ahr at a discharge rate of 20A (8 hours times 20A = 160 Ahr). The 8-hour time line starts at the origin and goes through the intersection of 160Ahr and 20A.

Similarly, it takes 3 hours to remove 120Ahr at a discharge rate of 40A, or 2 hours to remove 120Ahr at a discharge rate of 60A. In each case, a time straight line can be drawn based on this relationship as shown by the green lines in figure 28.17.

The time lines overlaid onto the voltage capability curves give the characteristic discharge curves in figure 28.17.

Example 28.1: Lead-acid battery discharge characteristics

Cell discharge tests produced the characteristic curves in figure 28.17, which describe the expected cell capacity as a function of discharge rate and minimum allowed cell voltage.

- i. A battery must carry a load of 400A for one hour without the battery voltage falling below 1.75V per cell. How many positive plates must the battery have to fulfil the load requirement?
- ii. What is the expected initial voltage for discharge rates of 70A and 110A, respectively? If a minimum cell voltage of 1.75V is allowed, what is the expected discharge rate per positive plate?
- iii. Suppose 80Ahr per positive plate of energy has been removed from the cell. What is the expected voltage if the battery is continued to be discharged at a rate of 40A per positive plate?
- iv. Estimate the cell internal resistance, hence the expected short circuit current, assuming a typical cell voltage of 2V. What is the internally generated power and the maximum power transfer?
- v. Estimate the expected short circuit current if 60 such cells are series connected to form a battery. What is the total internally generated power?

Solution

- i. On figure 28.18a, follow the green one-hour time line radially out to the intersection of the blue 1.75V curve. The capability of this positive plate is 70A, or, this plate can provide 70A of current for one hour before its voltage falls to 1.75V. A total of 400A is needed for the load. By dividing the 400A load by 70A per positive plate, the required number of positive plates is 5.7. Therefore, 6 positive plates fulfil the 400A load requirement.
- ii. The red initial volts line in figure 28.18a shows the expected instantaneous cell initial voltage for a given discharge rate. This is the voltage produced immediately upon application of a load. As shown, the initial voltage is 1.89V for a discharge rate of 70A per positive plate. The voltage falls to about 1.82V for a discharge of 110A per positive plate. There is a discharge rate that will cause the cell voltage to immediately fall to 1.75V. From figure 28.18a, this discharge rate is 140A per positive plate.

- iii. The discharge curves can be used to predict the cell voltage at various times during a discharge. Figure 28.18b shows that the expected voltage can be interpolated from the voltage curves at the intersection of 80Ahr per positive plate and 40A per positive plate. As shown, the expected voltage is about 1.86V.
- iv. The initial volts line can also be used to estimate cell internal resistance. Each point on this line describes an expected instantaneous voltage for the associated discharge rate. Any two points on the initial volts line can be used to obtain a difference in voltage for a difference in discharge rate (current). Ohm's law can be applied to calculate the internal resistance. In figure 28.18b, the initial voltage is about 1.94V for a discharge rate of 40A per positive plate and 1.83V for a discharge rate of 100A. The slope of the line is the effective internal resistance:

$$R = \frac{\Delta V}{\Delta I} = \frac{1.94V - 1.83V}{100A - 40A} = 1.833m\Omega/plate$$

This is the internal resistance of this particular cell with a single positive plate (and two negative plates). As additional positive (and negative) plates are added to the cell to increase its capacity, the positive plates can be modelled as parallel resistances. If the cell has 10 positive plates (and eleven negative plates), there are 10 parallel resistances of 1.833mΩ each. The cell equivalent internal resistance is given by:

$$cell\ resistance = \frac{1.833m\Omega}{10} = 0.1833m\Omega$$

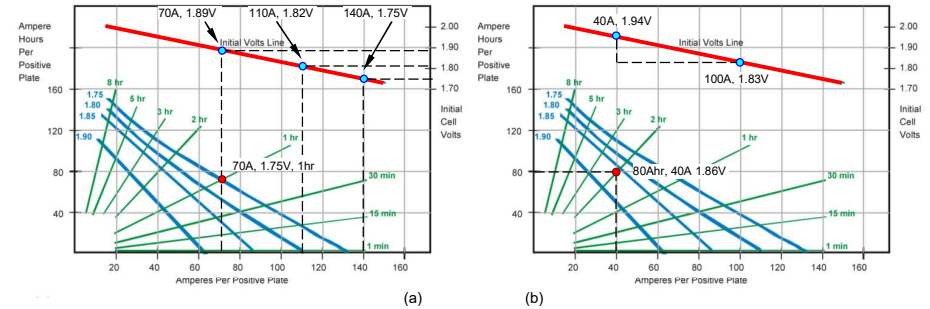

Figure 28.18. Typical battery discharge characteristics, for Example 28.1.

Given the cell voltage is about 2V, the expected short circuit current from the cell is:

$$I = \frac{V}{R} = \frac{2V}{0.1833m\Omega} = 10,909A$$

The internally generated heating power is

$$P = I^2 R = 10,909A^2 \times 0.1833m\Omega = 21.81kW$$

The maximum power transfer, when the load resistance equals the internal resistance, is 1/4 of 21.81kW, namely 5.45kW

- v. Just as the cell voltages add when series connected, so too do the internal resistances. The short circuit current is

$$I = \frac{V}{R} = \frac{\text{number of cells} \times 2V \text{ per cell}}{\text{number of cells} \times \text{internal resistance of one cell}} = \frac{60 \times 2V}{60 \times 0.1833m\Omega} = 0.1833m\Omega = 10,909A$$

The fault current for 60 series connected cells is the same as for each individual cell. The total internally generated heating power P_T is 60 times that in each cell, that is

$$P_T = 60 \times I^2 R = 60 \times 21.8kW = 1.31MW$$



ii. Self-discharge during storage – shelf life

LA batteries lose 2% to 3% capacity per month at 25°C when not in use, a phenomena termed self-discharge. Most batteries lose their stored energy when allowed to stand on open circuit, since the active materials are in a thermochemical unstable state. The rate of self-discharge is dependent on the cell chemistry, the quality of the active materials, as well as the temperature at which the battery is stored, as shown in figure 28.19. The use of pure raw materials decreases the rate of self-discharge and enhances storage life.

Loss of capacity during long storage or storage at high temperatures is compensated by periodically charging the battery, otherwise irreversible sulphation leads to permanent loss of capacity. If the open circuit voltage (OCV) falls below 2.1V at 20°C (approximately 60% residual capacity at a given temperature), at least every 6 months slow recharging to 2.4V per cell is necessary (for 96 hours or until the charging current remains constant for a three-hour period or falls below ½ percent of the battery’s 20 hour rated capacity). If a battery is stored at temperatures above 25°C, then the boost charge interval should be more frequent. If the terminal voltage of any cell falls below 2.1V, there is a risk of open circuit corrosion or irreversible sulphation.

The impact of temperature on a battery and its rated capacity and life is based on an environment temperature of 25°C. When the environment temperature is below 25°C, the battery capacity decreases and the life extends; when the environment temperature is over 25°C, the battery capacity increases and the life shortens.

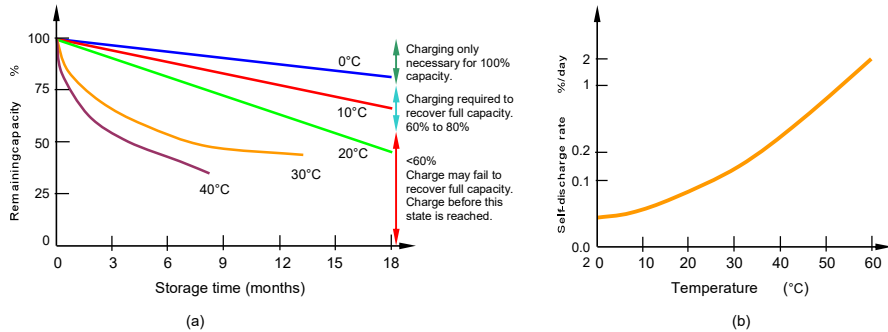

Figure 28.19. State of charge dependency: (a) self-discharge with storage time characteristics and (b) self-discharge dependence on temperature.

Typical self-discharge rates of lead acid batteries as a function of temperature are, 2% per month at 20°C, 4% per month at 30°C, 8% per month at 40°C, etc. That is, the self-discharge almost doubles by each 10°C rise in storage temperature.

iii. Cycle life

Primary reasons for short cycle life are grid corrosion of the positive plate, depletion of active material, and expansion of the positive plates, which are exasperated by higher temperatures; all are irreversible by charging/discharging cycling. Battery life specified for 25°C and under float charge, halves for every 9.4°C above this temperature, as shown in figure 28.20a.

The temperature corrected number of expected years of battery life is given by

$$L_{tc} = \frac{\text{rated service life at } 25^\circ\text{C}}{\sum_{T_i} \frac{1}{L_i} \times \text{months}@T_i} \quad (28.2)$$

where L_i is the % life at temperature T_i .

The expected number of cycles is dependant on depth of discharge, as shown in figure 28.20b.

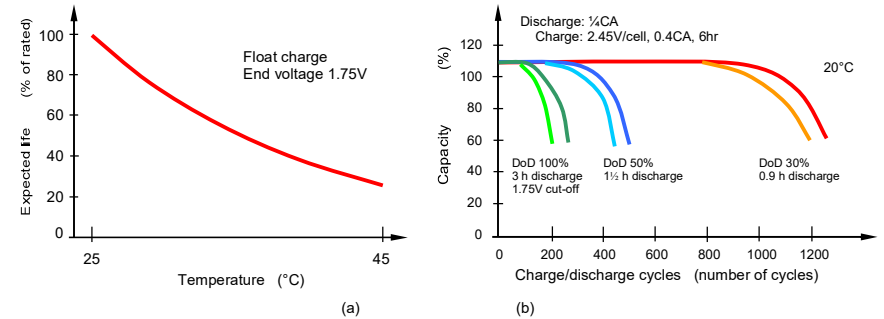

Figure 28.20. Temperature and depth of discharge (DoD) effects on lead-acid cell life.

Example 28.2: Lead acid battery life

A battery rated for 20 years operates at 25°C for all but 3 months of the year, when it operates at 40°C. What is the expected service life of the battery?

Solution

From equation (28.2) and figure 28.20a:

$$L_{tc} = \frac{\text{rated service life at } 25^\circ\text{C}}{\frac{1}{L_1} \times \text{months}@T_1 + \frac{1}{L_2} \times \text{months}@T_2}$$

$$= \frac{240 \text{ months}}{\frac{1}{1} \times 9 \text{ months} + \frac{1}{0.32} \times 3 \text{ months}} = \frac{240}{18.375} = 13.06 \text{ years}$$

iv. Service life related to impedance

Battery loss of Ahr capacity and increase in internal impedance is an indication of battery deterioration, whence lifetime, as indicated in figure 28.21.

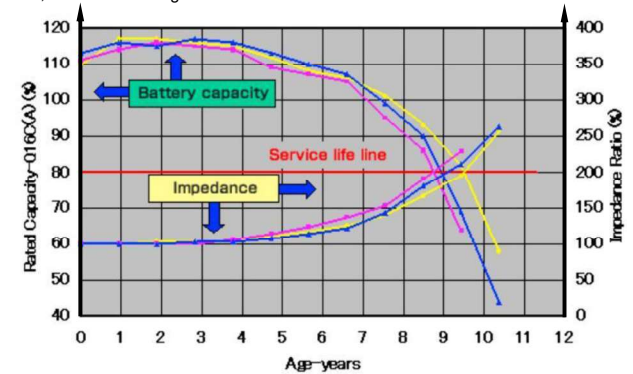

Figure 28.21. Battery impedance increase over battery lifetime.

v. Relation between Open-Circuit Voltage (OCV) and State of Charge (SoC)

The relation between open-circuit cell voltage and capacity retention is shown in figure 28.22.

Open circuit voltage varies according to ambient temperature and the remaining capacity of the cell. Generally, open circuit voltage is determined by the specific gravity of the electrolyte, where discharging a battery lowers the specific gravity, as shown in figure 28.12. Consequently, it is possible to determine the approximate remaining capacity of a battery from the terminal voltage. In flooded lead-acid batteries with filling caps, with acid access, it is possible to estimate the residual capacity of the battery by measuring the density of the acid.

However, this is not possible with valve-regulated batteries, thus leaving the value of the open circuit voltage as a method to approximate the residual capacity. The result of an open circuit voltage measurement, taken either 24 hours after a full charge or at least 10 minutes after discharge, in conjunction with figure 28.22, produces an approximation of the residual capacity.

The graph shows that a healthy, fully charged cell has an OCV of 2.14V or higher at 25°C. Open circuit voltage varies according to ambient temperature and the remaining capacity of the battery.

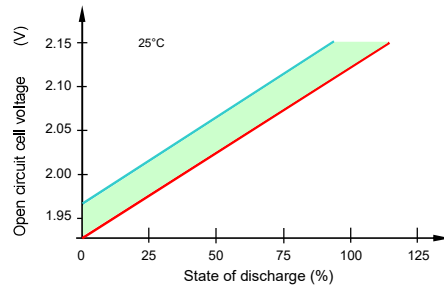

Figure 28.22. Relationship between open-circuit voltage and state of charge (residual capacity), 24 hours after charge, or 10 minutes after discharge, both at 25°C.

vi. Effects of temperature on capacity

Cell capacity is a function of ambient temperature and rate of discharge. At 20°C, rated capacity is 100%. Battery discharge is an electrochemical reaction between the electrodes (the plates) and the diluted sulphuric acid. When the discharge current is high, or the temperature is low, thereby causing a greater viscosity of the acid, the diffusion rate of the acid through the plates can no longer keep up with the discharge, reducing the capacity, as shown in figure 28.23. The capacity increases slowly above this temperature. Even at -40°C, however, a prime quality battery will still function at better than 40% of its rated capacity when discharged at the 20-hour rate, 0.05C. At any ambient temperature, the higher the rate of discharge, the lower the available capacity. This relationship is shown in figure 28.23a. Batteries may be discharged at temperatures ranging from -40°C to 60°C, possibly 80°C when metal case cooled, and charged at temperatures from -20°C to 50°C. Whilst raising the ambient temperature increases capacity, it also decreases useful service life. Battery life is halved for each 10°C rise above normal room temperature. As temperature increases, internal resistance decreases as shown in figure 28.23b.

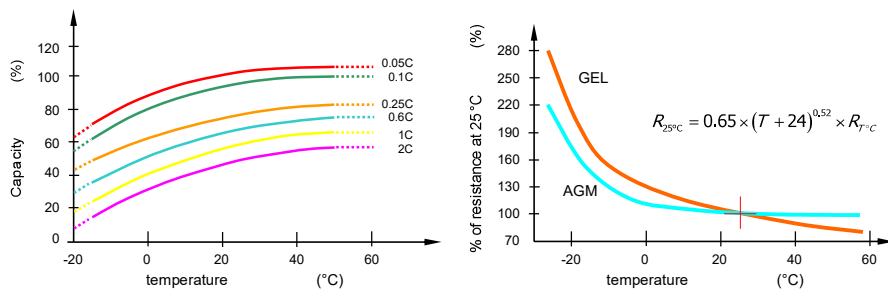

Figure 28.23. Effect of temperature on capacity and internal resistance.

28.4.7 Gassing and internal recombination

i. Gassing: Traditionally there are problems with the basic flooded-cell lead-acid battery design. If cell voltages exceed 2.39V, the water breaks down to hydrogen (at the anode) and oxygen (at the cathode). The chemical reactions are shown in Table 28.6. This 2.39V voltage is called the gassing voltage and is temperature and pressure dependent. Gassing requires replacement of the cell's water. Also, as the hydrogen and oxygen vent from the cell, too high a mixture concentration could cause an explosion. Another problem arising from an open system is that fumes from the acid solution can have a corrosive effect on the surrounding area.

Table 28.6: Lead-acid cell gassing and corrosion equations

undesirable plate chemical reactions		reaction
positive electrode cathode	oxygen evolution	$2H_2O \rightarrow O_2 + 4H^+ + 4e^-$
	grid corrosion	$Pb + 2H_2O \rightarrow PbO_2 + 4H^+ + 4e^-$
negative electrode anode	oxygen reduction	$O_2 + 4H^+ + 4e^- \rightarrow 2H_2O$
	hydrogen evolution	$2H^+ + 2e^- \rightarrow H_2$

These problems are basically solved with sealed cells. In the case of lead-acid cells, the term 'valve-regulated cells' is more accurate, because no rechargeable cell can be completely sealed. If sealed, the hydrogen gas pressure would build-up. Catalytic gas recombiners alleviate this problem by converting the hydrogen and oxygen back into water, with better than 90% efficiency. Although this does not entirely eliminate the hydrogen and oxygen gas, the water lost becomes so insignificant that no refill is needed for the life of the battery. For this reason, these cells are often referred to as maintenance-free batteries. Also, this cell design prevents corrosive electrolyte fumes from escaping.

ii. Theory of internal recombination

When an open flooded lead-acid cell is charged, a release of gas occurs. The charge current electrolyzes the water, decomposing it into its forming elements, initially oxygen from the positive electrode and subsequently hydrogen from the negative electrode. Thus water is lost from the cell, which must be replenished by means of frequent topping up with water. The nitrogen and carbon diode present, from air, are inactive.

The evolution of the two gases does not occur at the same time since the recharge efficiency of the positive electrode is less than that of the negative electrode. This means that oxygen is evolved from the positive plate before the negative plate can generate hydrogen. As oxygen is evolved from the positive plate, a significant quantity of highly active spongy lead exists on the negative electrode before the negative plate can generate hydrogen.

Should oxygen and hydrogen escape, a gradual drying out would occur, eventually affecting capacity and battery life. To maintain the chemical balance in the cell, the lost water must therefore be replaced periodically, involving time consuming verification and refilling of the electrolyte.

In valve-regulated batteries, however, the elements in the gases created are combined during the charge phase, with oxygen transported from the positive plate to the negative plate, through the so-called 'cycle of oxygen recombination', thereby producing water as described in the following cycle.

The internal design of the cell allows the oxygen generated at the positive plates to diffuse towards the negative plates, where hydrogen will be produced.

- The oxygen reacts chemically with the spongy lead of the active material to form lead oxide
- The sulphuric acid within the electrolyte then reacts with this lead oxide, forming lead sulphate and water
- The lead sulphate formed is transformed electrochemically into lead and sulphuric acid
- As long as the battery remains fully charged, this equilibrium is maintained.

The following internal recombination stages are summarised in figure 28.24.

1. At the end of charge or if overcharged, oxygen gas is generated and released at the positive plate due to water electrolysis:



and the oxygen is diffused through the microporous separators to the surface of the negative plates. In VRLA batteries, a densely porous medium is offered to the oxygen to facilitate its movement, namely, in AGM-batteries: pores in the glass mat; and in Gel batteries: cracks in the gel.

2. The process is reversed at the negative plate, with the recombination net effect being a slight generation of heat, which is minimised by using high purity materials.

On the negative plates, the oxygen that has diffused through the electrolyte from the positive plate chemically reacts, specifically absorption, and combines with a part of the spongy lead contained in these plates producing lead oxide:



3. The lead oxide combines with the sulphuric acid in the electrolyte, forming lead sulphate and water:



Part of the spongy lead is thus chemically discharged to a lead sulphate state and the water consumed at the positive plate is regenerated. Water is therefore regenerated on the positive plates, while lead sulphate is formed from the partially discharged negative plates.

4. The spongy lead which was chemically discharged at the negative plate is recharged chemically. The charge process recharges the partially discharged negative plates, thereby closing the cycle.

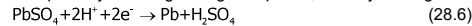

The recombination cycle, as described, is therefore theoretically complete as shown when equations (28.4) to (28.6) are added (see figure 28.24).



The constituent parts of water and sulphuric acid in the electrolyte, as well as the amount of negative plate lead, reappear at the end of the process in their original state, without having modified the charge conditions of the plates. The water content of the electrolyte thus remains unchanged unless the charging rate is too high. Recombination yields tend to be slightly less than complete, giving approximately 98% efficiency.

During overcharge or abnormal charge at less than the specific temperature, the amount of oxygen gas generated by reaction equation (28.3) cannot be fully-absorbed by the reaction on the negative plate, equation (28.7). The internal pressure increases, activating the safety valve, releasing the excessive gas including hydrogen generated (along with oxygen) at the negative plate during excessive overcharge.

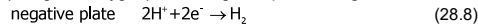

H₂ generation increases with increased float voltage, temperature, and altitude (decreased pressure), with lead-antimony generating far more gas than the equivalent calcium-lead grid cell, at the end of life. When the safety valve operates, electrolyte is consumed and cell performance deteriorates. In the flooded cell, oxygen and hydrogen escape to the environment, as shown in figure 28.25a. In the VRLA case, oxygen evolved from the positive plate transfers through the electrolyte to the negative plate and recombines with the generated hydrogen to form water, as shown in figure 28.25b.

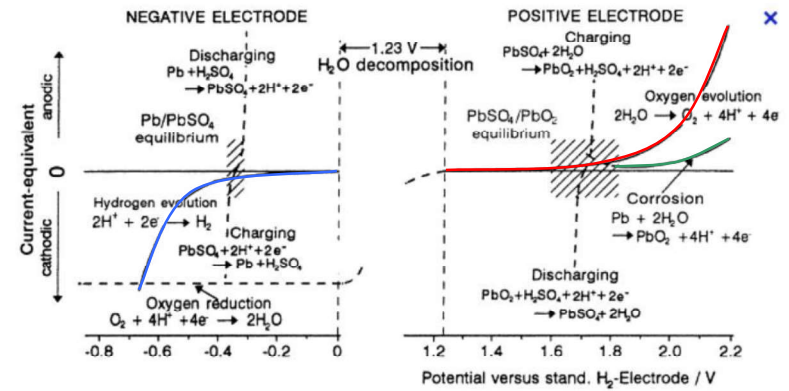
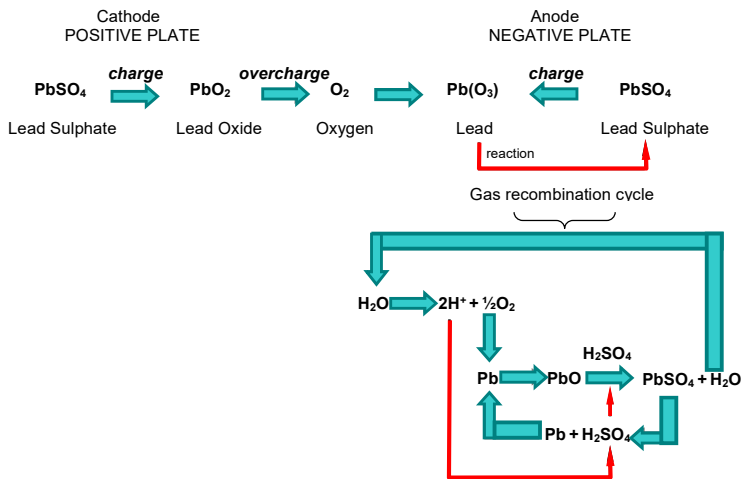

Figure 28.24. Gas recombination reaction cycle at negative lead plate.

iii. Necessary conditions for recombination

To facilitate the diffusion of oxygen, uniform and porous separators are used. To avoid saturating the available porosity of the separators, the quantity of electrolyte is carefully measured, ensuring that the electrolyte is completely contained inside the plates and the separators, leaving no free electrolyte inside the battery container. To prevent contact of the lead of the negative plates and the oxygen contained in the surrounding atmosphere, and the consequential chemical oxidation, the electrical elements are held in fully closed containers. At the same time, it is also necessary to allow the venting of any over-pressurization of gases, which may be generated within the container during anomalous and/or overly harsh charging conditions. The one-way valve allows excess gases to be vented when required, but does not permit outside air to enter. The presence of a one-way valve therefore gives rise to the 'valve-regulated' terminology, rather than the more commonly used, but inaccurate, 'sealed' terminology.

Since it is more volume efficient to fill a container with a liquid than a semi-solid, AGM batteries require less space between battery plates. The closer plate spacing gives the AGM battery a lower internal resistance, making it more charge efficient, with better power performance on discharge, especially at low temperatures.

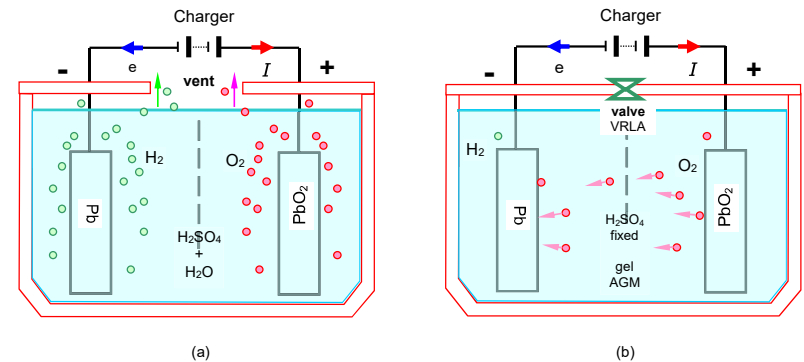

Figure 28.25. Gassing and recombination in vented lead-acid and VRLA batteries.

28.4.8 User properties and cell type comparisons

i. Lead-acid battery user properties

General lead-acid battery properties are summarised in Table 28.2 and in the points that follow. Used mainly for engine batteries, the lead-acid cells represent over half of all battery sales. Some advantages are low cost, modest life cycle, and the ability to withstand electrical mistreatment. They also perform adequately in high and low temperatures and in high-drain applications. Lead-acid cells have a low cycle life if deeply cycled and low energy densities, normally between 30 and 40Whr/kg. However, with a nominal cell voltage of 2V and power densities of up to 600W/kg, the lead-acid cell is adequate for automotive batteries. Lead acid chemistry predicts a battery theoretically capable of delivering approximately 170Whr/kg, but even the most efficient lead-acid battery produce energy densities, on average, of no more than 30-50Whr/kg.

Advantages

- Inexpensive and simple to manufacture.
- Mature, reliable and well-understood technology that is durable and dependable.
- Self-discharge is among the lowest of rechargeable battery systems. Low maintenance.
- Capable of high discharge rates, due to low internal impedance.
- No memory.
- Recyclable.

Limitations

- Low energy density limits use to stationary and wheeled applications.
- VRLA cells can never be charged to their full potential – if excessive gassing is to be avoided.
- Cannot be stored in a discharged condition - the cell voltage should never fall below 2.10V.
- A limited number of full discharge cycles, but is suited for standby applications.
- Lead content and acid electrolyte make the battery environmentally unfriendly, but recyclable.
- Transportation restrictions on flooded lead-acid cell due to environmental spillage concerns.
- Thermal runaway can occur if improperly charged.
- Heavy and bulky.

ii. Differences between VRLA batteries and traditional wet flooded batteries

Wet flooded batteries do not have pressurized sealing vents, as they do not operate on the recombination principle. They contain liquid electrolyte that can spill and cause corrosion if tipped or punctured. Therefore they are not air transportable without special containers and can only be installed 'upright'.

Wet batteries lose capacity and become permanently damaged if:

- left in a discharged condition for any length of time (due to sulphation). This is especially true of antimony and hybrid types.
- continually over-discharged, due to active material shedding, particularly automotive starting types.

The shelf life of a valve-regulated lead-acid **VRLA battery** is seven times longer than the shelf life of a deep cycle flooded antimony battery.

VRLA technology encompasses both gelled electrolyte and absorbed glass mat (AGM) batteries. Both have significant advantages over flooded lead acid products. A VRLA battery is a 'recombinant' battery. This means that the oxygen normally produced on the positive plates of all lead-acid batteries is absorbed by the negative plate. This suppresses the production of hydrogen at the negative plate. Water, H₂O is produced instead, retaining the electrolyte within the battery. It never needs watering, and should never be opened as this would 'poison' the battery with additional oxygen from the air.

VRLA AGM and to a lesser extent Gel technology, can be used in any orientation, but charging should be avoided in the inverted position, due to the vent orientation.

iii. Differences between gel batteries and absorbed glass mat (AGM) batteries

Both are recombinant batteries being valve-regulated lead-acid (VRLA). Both AGM and Gel batteries utilize oxygen recombination and pressure relief valves to minimize water loss and allow maintenance-free operation. AGM batteries and gel batteries are both considered 'acid-starved', between 90 and 95 percent - but not fully, saturated. The 'acid-starved' condition of gel and AGM batteries protects the plates during heavy deep-discharges. That is where the similarities end.

The **gel** battery is more starved, giving more protection to the plates; therefore, it is better suited for deep discharge applications. The electrolyte does not flow like a normal liquid; rather it has the consistency and appearance of petroleum jelly. It is a highly viscous, semisolid mixture of silica gel with dilute sulphuric acid in a colloidal suspension. The electrolyte is difficult to keep homogeneous and the solid silica can separate from the acid, creating a 'flooded' battery. Vibration is an operational factor that can cause the silica and acid mixture to separate, as there is no chemical bond. In high temperature

environments, the semisolid electrolyte develops cracks and voids that reduce contact between the plates and cause the battery to lose capacity. This same effect gradually occurs even at room temperatures.

Like gelled electrolyte batteries, absorbed electrolyte batteries **AGM** are also considered non-spillable, since the liquid electrolyte is trapped in the sponge-like matted glass micro-fibre separator material.

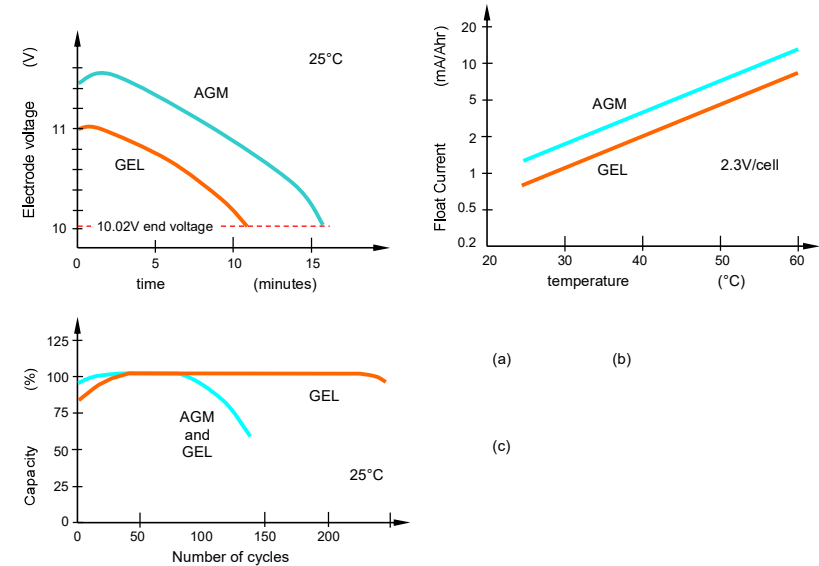

Figure 28.26. Comparison between Gel and AGM batteries: (a) high discharge rate performance, (b) float current versus temperature; and (c) VRLA battery cycle life.

Shrinkage of the separator does not occur as the battery ages and the electrolyte remains in direct contact with the plates. The electrolyte remains immobilized even when the battery is exposed to severe vibration, so electrolyte spillage or leakage is prevented.

Due to the physical properties of the gelled electrolyte, **gel** battery power declines faster than an **AGM** battery's as the temperature drops below 0°C. **AGM** batteries excel for high current, high power applications, and in sub-zero environments. **AGM** batteries have the advantage of being mountable in any orientation without capacity loss, while **gel** batteries preferably should be mounted upright to prevent air pockets from forming that will burn out the plates. They have inferior performance at high discharge rates and low temperatures.

Gel batteries are more sensitive to charging voltage. If the charging voltage is not controlled within a tight range relative to the battery's temperature, the life of the battery will be adversely affected. For example, if the charging voltage is 60mV/cell higher than the recommended level, the cycle life is reduced by 60 percent. The reason for this effect is the limited oxygen recombination capability of gelled batteries. **AGM** batteries are more forgiving in overcharge conditions and their ability to recombine the hydrogen and oxygen gases back into water is more efficient. With **AGM** batteries, increasing the charging voltage 85mV/cell above the recommended charging voltage results in only a 23% reduction in the cycle life.

The charge acceptance of **gel** batteries is also less than that of **AGM** batteries. This means it takes longer to recharge **gel** batteries. As an example, when discharged to 50% of rated capacity (common in a deep cycle applications), gel batteries take twice as long as AGM batteries to reach full charge.

The **AGM** VRLA battery has a slightly more efficient oxygen recombination cycle and a lower resistance than the gelled electrolyte VRLA battery. As a result, it draws slightly more float charge current, as shown in figure 28.26b, resulting in greater internal heating. The **gelled** electrolyte is in complete contact with the plates and the container walls where the heat is dissipated. The electrolyte, in the AGM case is not in complete contact with the heat-dissipating casing, resulting in 15% less heat conduction from the plates.

In the case of the gelled electrolyte, the addition of phosphoric acid to the electrolyte, with special separators, minimise paste shedding, making the cell more capable of enduring the stresses of deep cycling, as shown in figure 28.26c. Adversely, the phosphoric acid reduces the initial capacity by about 10% of AGM and standard gelled cells.

The following table, 28.7 provides a one-to-one comparison between AGM and GEL batteries.

Table 28.8: Advantages and disadvantages of the different types of lead acid battery designs

The different types of lead acid battery designs			
	Gelled Electrolyte	Absorbed Electrolyte	Flooded Electrolyte
Advantages	<ul style="list-style-type: none"> Totally maintenance-free Air transportable Spill-proof/leak-proof No corrosion Installs upright or on side (side installation may lose about 10% capacity) Compatible with sensitive electronic equipment Very low to no gassing (unless overcharged) Superior shelf life Very safe at sea with no chlorine gas in bilge (due to sulphuric acid and salt water mixing) Operates in wet environments - even under 10m of water Rugged and vibration-resistant Versatile: starting, deep cycle, stationary Superior deep cycle life Will not freeze to -30°C (if fully charged) Superior rechargeability (from 0% to 90% in 3½ hours) No recharge current limitation @ 2.3V/cell Lowest cost-per-month (cost/months of life) Lowest cost-per-cycle (cost/life cycles) 	<ul style="list-style-type: none"> Totally maintenance-free Air transportable Spill-proof/leak-proof No corrosion Installs upright or on side Compatible with sensitive electronic equipment Very low to no gassing (unless overcharged) Superior shelf life Very safe at sea with no chlorine gas in bilge (due to sulphuric acid and salt water mixing) Operates in wet environments - even under 10m of water Rugged and vibration-resistant Excellent for starting and stationary applications Superior for shorter duration/higher rate discharges High charge acceptance rate Superior under extreme cold conditions when fully charged Superior rechargeability (from 0% to 90% in 3½ hours) Low self-discharging rate Lower cost than gel cell batteries 	<ul style="list-style-type: none"> Higher cranking amps Certain designs are good for deep cycle applications Excellent for starting applications Good under extreme cold conditions when fully charged More resilient and tolerant of improper recharge voltage Water can be added (if accessible) Lowest initial cost Replacements readily available lighter in weight
	Disadvantages	<ul style="list-style-type: none"> Higher initial cost Heavier weight Water cannot be replaced if continually overcharged Automatic temperature-sensing, voltage-regulated chargers must be used Charge voltage must be limited to extend life (2.3 to 2.35V/cell maximum at 25°C) 	<ul style="list-style-type: none"> Expensive and heavy Shorter cycle life than gel when very deep cycled Water cannot be replaced if continually overcharged Automatic temperature-sensing, voltage-regulated chargers must be used Charge voltage must be limited (2.4 to 2.43V/cell maximum at 25°C)

Table 28.7: Comparison between AGM and GEL VR LA batteries

Battery Characteristic	VRLA AGM	VRLA Gel
Electrolyte Stability	Has all of its electrolyte absorbed in separators consisting of a sponge-like mass of matted glass fibres.	Uses thixotropic gelled electrolyte.
	Excellent AGM acts like a flexible sponge. Lower acids density gives longer service life. Because acid is not immobilised, stratification can occur.	Prone to solid / liquid separation leading to spillage / spewage of acid and premature failure. Electrolyte loses contact with plates due to cracks and voids as the battery ages, especially at higher ambient temperatures.
High Rate Performance	Excellent due to low internal impedance due to close proximity plates.	Inferior Plate spacing must be greater to allow for gel passage during filling. Gel adds to impedance (presence of SiO ₂), especially at low temperatures.
Sensitivity to Charging Voltage Levels	Moderately sensitive Life is reduced if charged outside of recommended charge voltage levels.	Very sensitive Life is greatly reduced if charged outside of recommended charge voltage levels.
Charge Acceptance Rate	Excellent Battery can be fully charged (due to high acid density) in two hours if high inrush current is available.	Inferior Must limit inrush current and charge time is at least twice as long to reach full charge.
Similarities	'Sealed' using pressure valves and should never be opened. Maintenance-free. Non-spillable, and therefore can be operated in virtually any position. However, upside-down installation is not recommended, during charging. Uses a recombination reaction to avoid the escape of hydrogen and oxygen gases normally lost in a flooded lead-acid battery (particularly in deep cycle applications).	

28.5 The nickel-cadmium battery

Anode: Cadmium hydroxide (plus iron oxide for capacity stabilisation and to enhance cycle life)
 Cathode: Nickel oxyhydroxide NiO-OH (plus graphite for improved conductivity) - positive plate
 Electrolyte: Aqueous potassium hydroxide KOH 7M (a base solution), plus lithium hydroxide
 Applications: Calculators, digital cameras, pagers, laptops, tape recorders, flashlights, medical devices (for example, defibrillators), electric vehicles, space applications
 Typical ratings: Specific energy density: 45 to 80 Wh/kg
 Volumetric energy density: 50 to 150 Wh/l

The cathode is nickel-plated steel, woven mesh, and the anode is a cadmium-plated steel net, termed a *pocket plate*. The active materials are retained in the pockets formed by the mesh, as shown in figure 28.27. Since the cadmium is just a coating, this cell's negative environmental impact is often overstated. Separation between plates is provided by injection moulded micro-porous polymer separator grids, integrating both plate functions of edge insulation and plate separation. Retainers are not necessary since shedding and loss of active material do not occur.

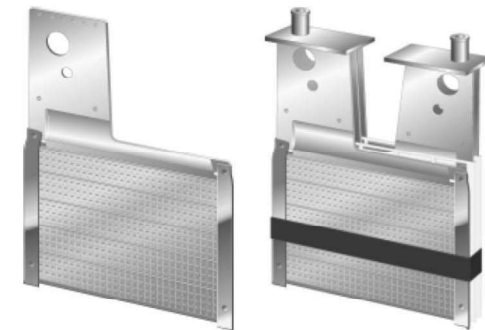

Figure 28.27. NiCd plates.

The electrolyte is an aqueous solution of potassium hydroxide containing small quantities of lithium hydroxide to improve cycle life and to facilitate higher temperature operation. Nickel-cadmium electrode material is less reactive with the alkaline electrolyte than lead is with acid electrolytes. During charging and discharging the electrolyte in alkaline batteries functions mainly as a carrier of oxygen or hydroxyl ions from one electrode to the other; hence the composition or the concentration of the electrolyte does not change noticeably. A cell level comparison between NiCd and lead-acid cell design characteristics is presented in Table 28.9.

Rather than venting, units are valve-sealed and the internal gases generated during charge, recombine. The casing is usually of durable polypropylene or flame retardant polyamid, nylon.

Table 28.9: Comparison of Nickel-Cadmium (NiCd) and Lead-Acid cell constructions

Parameter/Cell Dimension		Sealed Ni-Cd	Sealed Lead-Acid
Separator Thickness	mm	<1 mm	1-2 mm
Separator Material		Nylon or polypropylene	Glass microfiber
Separator Porosity	%	85-95	85-95
Electrolyte Volume	cm ³ /Ah	~4	~8-10
Electrolyte in Separator	%	~10	~75
Electrolyte in Plates	%	~90	~25
Saturation Level of Separator	%	20-30	80-90
Saturation Level of Negative Plate	%	70-80	50-60
Total Cell Pore Filling	%	50-60	70-90
Negative Plate Film Thickness	mm	~0.003	~0.1
Positive Plate Film Thickness	mm	~0.01	~0.01
Electrolyte Composition	Mol	~7 M KOH	~5 M H ₂ SO ₄
O ₂ Diffusion Coefficient in Electrolyte	cm ² /s	6 × 10 ⁻⁶	9 × 10 ⁻⁶

The NiCd half-cell chemistry reactions are shown in Table 28.10.

Table 28.10: Half-cell electro-chemical equations for the nickel-cadmium cell

Location	Half-Reaction (discharge)	165A-hr/kg	Potential
Anode	Negative terminal	$Cd_{(s)} + 2OH^-_{(aq)} \rightarrow Cd(OH)_{2(s)} + 2e^-$	$E^-_{cell} = -0.81V$
Cathode	Positive terminal	$2NiOOH_{(s)} + 2H_2O + 2e^- \rightarrow 2Ni(OH)_{2(s)} + 2OH^-$	$E^+_{cell} = 0.49V$
Net REDOX reaction		$Cd_{(s)} + 2NiOOH_{(s)} + 2H_2O \rightarrow Cd(OH)_{2(s)} + 2Ni(OH)_{2(s)}$	$E^o_{cell} = 1.30V$

i. NiCd battery charging

New, unused NiCd batteries should be slow-charged for 24 hours before use. The slow charge brings each cell within a battery to an equal charge level since each cell self-discharges to a different capacity level. During long storage, the electrolyte tends to gravitate to the bottom of the cell. The initial trickle charge aids electrolyte redistribution to remedy any dry spots on the separator. Batteries are not fully form when shipped and only reach their full potential after priming through several charge/discharge cycles. 50 to 100 discharge/charges may be needed to fully form a nickel-based battery, while better quality cells perform to rated specification after as few as 5 to 7 discharge/charge cycles. Early charger readings may be inconsistent, but the capacity levels become stable once fully primed. Nickel-cadmium prefers fast charge (10 minutes to 2 hours) to slow charge and pulse charge to dc charge. Fast charging is possible because the recharging chemical reaction is endothermic which counters the recharging I^2R losses, giving a lower cell temperature during charging. A slight capacity peak is observed between 100 and 300 cycles.

Most rechargeable cells are equipped with a safety vent to release excess pressure if incorrectly charged. The safety vent on a NiCd cell opens at 1000 to 1400 kPa (150 to 200 psi). With a resealable vent, no damage occurs on venting but some electrolyte is lost and the seal may leak afterwards, with a white salt powder accumulating over time at the vent opening.

Simple inexpensive charge termination by temperature sensing alone is not accurate. The thermistors used commonly exhibit broad tolerances; their positioning with respect to the cells is not consistent. Ambient temperatures while charging also affect the accuracy of full-charge detection. To prevent the risk of premature cut-off and assure full charge under most conditions, 50°C is used as a cut-off temperature.

More advanced NiCd charging methods sense the rate of temperature increase, defined as dT/dt , or the change in temperature over charge time, rather than responding to an absolute temperature (dT/dt is defined as delta temperature / delta time). Although better than fixed temperature cut-off, the cells still need to generate heat to trigger detection. A temperature increase of 1°C per minute with an absolute temperature cut-off, TCO, of 60°C is used to terminate the charge. Because of the relatively large mass of a cell and the sluggish propagation of heat, the delta temperature enters a brief overcharge condition before the full-charge is detected. The dT/dt method is only applicable to fast charging.

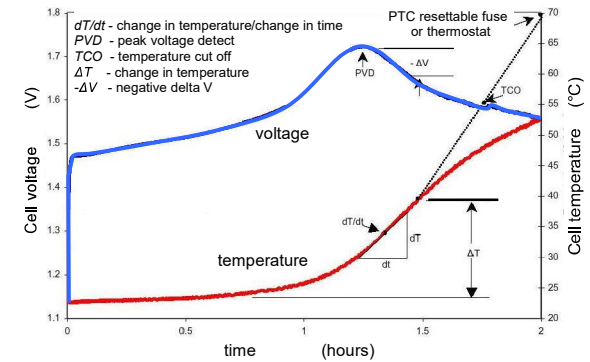

Figure 28.28. NiCd charge termination terminology.

Harmful overcharge occurs if a fully charged battery is repeatedly topped charged. Repetitive connection to power affects mostly 'dumb' nickel-based batteries. A 'dumb' battery contains no electronic circuitry to communicate with the charger. Li-ion chargers detect the SoC by voltage only and multiple reconnections will not confuse the charging regime. More precise full charge detection of nickel-based batteries can be achieved with electronic monitoring of the battery voltage and terminates the charge when a certain voltage signature occurs. A drop in voltage signifies that the battery has reached full charge, as shown in figure 28.28. This is known as Negative Delta V, $-\Delta V$, NDV.

NDV, is applicable for full-charge detection for 'open-lead' NiCd chargers because of its fast response time. NDV charge detection is also applicable to a partially or fully charged battery. If a fully charged battery is connected, the terminal voltage rises quickly, then drops sharply, triggering the ready state. Such a charge lasts only a few minutes and the cells remain cool. NiCd chargers based on NDV full charge detection typically respond to a voltage drop of 10 to 30mV per cell.

To obtain sufficient voltage drop, the charge rate must be ½C and higher. Lower charge rates produce a shallow voltage decrease that is difficult to detect, especially if the cells are slightly mismatched. In a battery that has mismatched cells, each cell reaches the full charge at a different time and the curve becomes distorted. Failing to achieve a detectable negative slope allows the fast-charge to continue, causing excessive heat build-up due to overcharge. Chargers using NDV must include other charge-termination methods, mostly battery temperature, to provide safe charging under all conditions.

The charge efficiency factor of a standard NiCd cell is better on fast charge than slow charge. At a 1C charge rate, the typical charge efficiency is 1.1 or 91%. On a slow charge, ½C, the efficiency drops to 1.4 or 71%. At a rate of 1C, the charge time is 66 minutes at an assumed charge efficiency of 1.1. The charge time of a NiCd battery that is partially discharged or cannot hold full capacity due to memory or other degradation, is shorter. At a ½C charge rate, the charge time of a discharged NiCd cell is about 14 hours, which relates to a charge efficiency of 1.4.

During the first 70% of the charge cycle, the charge efficiency is almost to 100%. Virtually all the energy is absorbed and the NiCd battery remains cool. Currents of several times the C-rating can be injected into a NiCd battery designed for fast charging without causing heat build-up. Ultra-fast chargers use this unique phenomenon and charge a battery to the 70% charge level within a few minutes. The charge then continues at a lower rate until the battery is fully charged.

Once the 70% charge threshold is reached, the battery gradually loses ability to accept charge, as illustrated in figure 28.29b. The cells start to generate gases, the pressure rises and the temperature increases. The charge acceptance drops further as the battery reaches 80% to 90% SoC. Once full charge is reached, the battery goes into overcharge. In an attempt to gain extra capacity, a measure of overcharge is acceptable. Figure 28.29a illustrates the relationship between cell voltage, pressure and temperature while a NiCd cell is being charged. Ultra-high capacity NiCd batteries tend to heat up more than the standard NiCd cells if charged at 1C and higher. This is partly due to the higher internal resistance of the ultra-high capacity battery. Optimum charge performance can be achieved by applying higher current at the initial charge stage, then tapering it to a lower rate as the charge acceptance decreases. This avoids excess temperature rise, yet assures a fully charged battery.

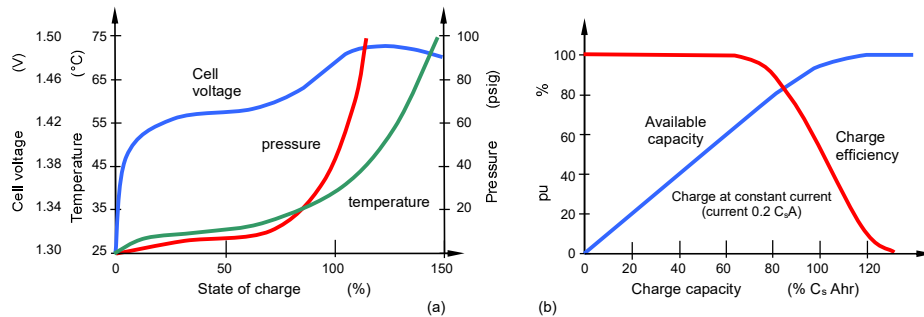

Figure 28.29. Charge characteristics of a NiCd cell:
(a) the cell voltage, pressure and temperature characteristics are similar to a NiMH cell and
(b) charge efficiency as a function of state of charge.

Interspersing discharging and charging pulses improves the charge acceptance of nickel-based batteries. Commonly referred to as 'burp' or 'reverse load' charge, this charge method promotes high surface area on the electrodes, resulting in enhanced performance and increased service life. Interspersed discharging also improves fast charging because it helps to recombine the gases generated during charge. Charging with the reverse load method minimizes crystalline formation. The result is a cooler and more effective charge than with dc charging with an added 15% to the life of the NiCd battery.

After full charge, the NiCd battery is maintained with a trickle charge to compensate for the self-discharge. The trickle charge for a NiCd battery ranges between 0.05C and $\frac{1}{10}C$, with lower trickle charge currents reducing the memory phenomenon. This 'floating' voltage should be in the range 1.42V to 1.45V to ensure that the battery continues to accept a small level of charge. Temperature compensation reduces battery water consumption.

ii. **Balancing:** Cell-to-cell balance in batteries is a major concern. Imbalances can drive one or more cells in a battery into reversal, thus causing damage and possibly resulting in initially oxygen generation at the negative electrode and then hydrogen at the positive nickel electrode. The oxygen will eventually recombine but the hydrogen will lead to pressure build-up. Although nickel-cadmium cells do generate hydrogen on normal over-charge, these occurrences are minor compared to VRLA systems.

iii. **Gassing:** Sealed nickel-cadmium cell technology has been developed to optimize the efficiency of the oxygen-recombination process. The chemistry is such that the cells can be operated in a starved condition (relative to valve-regulated lead-acid, VRLA, systems) and under normal operating conditions, there is no venting of gases because the cells have a thin, oxygen-permeable separator with a high void volume and an overbuilt active spongy cadmium-negative electrode with a thin electrolyte film. Unlike the lead-acid system, the primary function of the electrolyte is to provide good conductivity within the cell and only water is involved in the overall cell reaction, leaving the KOH electrolyte relatively unchanged during charge/discharge cycling. Table 28.11 compares lead acid and NiCd chemistries. Sealed nickel-cadmium cells have self-resealing safety vents that release gas due to any pressure build-up, but they are normally intended to operate at high internal pressures with minimal gassing. The positive plate is

designed to enter overcharge first, thus generating oxygen, and transport to, and recombination at the negative plate, is promoted. Because it is overbuilt, relative to the positive electrode and constantly being oxidized by oxygen, the cadmium anode (negative) electrode does not normally reach a potential where hydrogen is generated. This is also facilitated by a carefully controlled, narrow fill-weight range that is enough to provide good conductivity and small enough so the separator and plate pores are not flooded, which would lead to a pressure build-up. As summarised in Table 28.11, the reactions become:

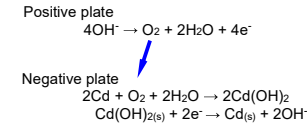

Because no gases are usually given off, all the overcharge current goes into heat generation. Therefore, charging and thermal management are critical NiCd issues; only constant-current charging is recommended for nickel-cadmium cells and only at moderate and low continuous levels, less than $\frac{1}{3}C$ (a current of one third the AH rating for three hours).

Table 28.11: Comparison of Nickel-Cadmium and Lead-Acid Chemistries

Chemistry	Nickel-Cadmium	Lead-Acid
Negative	$\text{Cd}(\text{OH})_{2(\text{s})} + 2\text{e}^- \leftrightarrow \text{Cd}(\text{s}) + 2\text{OH}^-$	$\text{PbSO}_{4(\text{s})} + 2\text{e}^- + \text{H}^+ \leftrightarrow \text{Pb}(\text{s}) + \text{HSO}_4^-$
- Overcharge	$2\text{H}_2\text{O} + 2\text{e}^- \leftrightarrow \text{H}_2 + 2\text{OH}^-$	$2\text{H}^+ + 2\text{e}^- \leftrightarrow \text{H}_2$
Positive	$\text{Ni}(\text{OH})_{2(\text{s})} + \text{OH}^- \leftrightarrow \text{NiOOH}(\text{s}) + \text{e}^-$	$\text{PbSO}_{4(\text{s})} + 2\text{H}_2\text{O} \leftrightarrow \text{PbO}_{2(\text{s})} + 3\text{H}^+ + \text{HSO}_4^- + 2\text{e}^-$
+ Overcharge	$4\text{OH}^- \leftrightarrow 2\text{H}_2\text{O} + \text{O}_2 + 4\text{e}^-$	$2\text{H}_2\text{O} \leftrightarrow \text{O}_2 + 4\text{H}^+ + 4\text{e}^-$
Overall Cell Process	$\text{Cd}(\text{s}) + 2\text{NiOOH}(\text{s}) + 2\text{H}_2\text{O} \leftrightarrow \text{Cd}(\text{OH})_{2(\text{s})} +$	$\text{Pb}(\text{s}) + \text{PbO}_{2(\text{s})} + 2\text{H}_2\text{SO}_4 \leftrightarrow 2\text{PbSO}_{4(\text{s})} + 2\text{H}_2\text{O}$
Recombination Reaction	$2\text{Cd}(\text{s}) + \text{O}_2 + 2\text{H}_2\text{O} \leftrightarrow 2\text{Cd}(\text{OH})_{2(\text{s})}$	$2\text{Pb}(\text{s}) + \text{O}_2 + 2\text{H}_2\text{SO}_4 \leftrightarrow 2\text{PbSO}_{4(\text{s})} + 2\text{H}_2\text{O}$

iv. **Water consumption and gas evolution:** During charging, more ampere-hours are supplied to the battery than the discharge capacity. These additional ampere-hours must be provided to return the battery to the fully charged state and, since they do not all contribute directly to the chemical changes in the plate active materials, they are dissipated. The current associated with this surplus charge, or overcharge, breaks down the water content of the electrolyte into oxygen and hydrogen, with pure distilled water having to be added to replace this loss.

A battery that is constantly cycled, that is, charged and discharged on a regular basis, will consume more water than a battery on standby operation.

In theory, the quantity of water used can be found by the Faradic equation that each ampere-hour of overcharge breaks down 0.366cc of water. However, in practice, the water usage is less, as the overcharge current is also needed to support self-discharge of the electrodes. The overcharge current is a function of both voltage and temperature and so both influence the water consumption.

Figure 28.30 gives typical water consumption values over a range of voltages and temperatures. Gas evolution is a function of the amount of water electrolysed into hydrogen and oxygen that are predominately given off at the end of the charging period. A battery gives off no gas during discharge.

Electrolysis of 1cc of water produces about 1865cm³ of gas mixture in the proportion $\frac{2}{3}$ hydrogen to $\frac{1}{3}$ oxygen. That is, the electrolysis of 1cc of water produces about 1243cm³ of hydrogen.

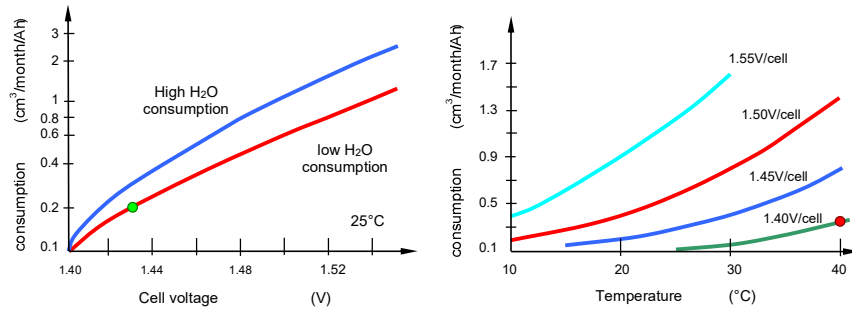

Figure 28.30. NiCd discharge water consumption for different voltages and different (a) plate types and (b) temperatures.

Example 28.3: NiCd battery electrolyte life

A NiCd, 161Ah, low water consumption battery floats at 1.43V per cell. How long before electrolyte reserve depletion, at 25°C, if the electrolyte reserve for each cell is 500cm³. How long before depletion if the float voltage is reduced to 1.40V/cell in an attempt to compensate for 40°C ambient conditions?

Solution

From figure 28.30a (the lower curve represents the cell with lowest water consumption), a NiCd cell at 1.43V per cell will use 0.20cm³/month for 1Ah of capacity. Thus each cell will use 0.20cm³/month/Ah x 161Ah = 32.2 cm³ per month and the electrolyte reserve will be used in $\frac{500\text{cm}^3}{32.2\text{cm}^3/\text{month}} = 15.5$ months

From figure 28.30b, at 1.4V/cell and 40°C, each cell will use 161Ah x 0.35cm³/month/Ah = 56.4 cm³/month, and the reserve will be depleted in 500cm³/56.4 = 8.9 months.

v. Discharge: Nickel-cadmium performs well in high-discharge and low-temperature applications, as indicated in the parts of figure 28.31. It also has a long shelf and service life but costs more than the lead-acid battery and has a lower power density but higher energy density. Nickel-cadmium is the only battery type that performs well under rigorous working conditions. All other chemistries prefer a shallow discharge and moderate load currents. Discharges of 10C can be tolerated for short durations. Although there is shift towards batteries with higher energy densities and less toxic metals, alternative chemistries cannot always match the superior durability and low cost of nickel-cadmium. The typical short circuit current is approximately 15 to 30 times the ampere-hour capacity. The nickel-cadmium battery is tolerant to high ripple current, with the only effect being increased water usage.

vi. NiCd high current discharge: High rate nickel-cadmium cells will deliver high currents. If the cells are discharged continuously under short circuit conditions, self-heating may incur irreparable damage. The heat problems involve the internal metal strip tab connectors overheating or the electrolyte boiling, or both. Overheating can be prevented by using the battery surface temperature to determine when to reduce the loading to allow cooling. A cut-off temperature of 60°C during discharge is acceptable. Overheating of the internal connectors is difficult to detect, as it takes place in a few seconds or less, producing minimal overall cell temperature increase. Output capacity that is composed of pulses make it difficult to predict temperature effects accurately because there are infinite combinations of current, 'on' time, rest time, and endpoint voltage. Testing on a specific cycle is the simplest way to benchmark temperature issues.

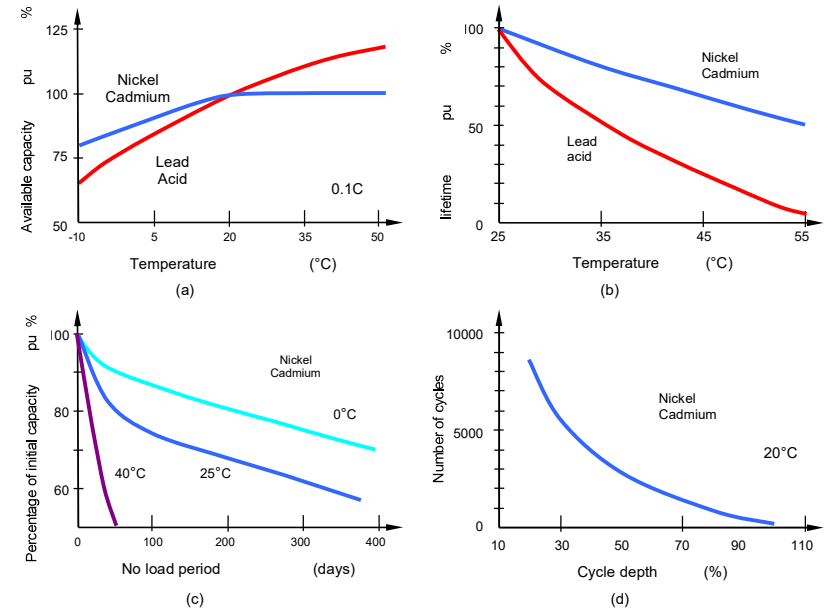

Figure 28.31. NiCd discharge characteristics: (a) effect of operating temperature on cell capacity at 0.1C cell discharge rate; (b) effect of temperature on lifetime at 25°C; (c) no-load capacity loss; and (d) cycle life dependence on depth of discharge as a percentage of rated capacity.

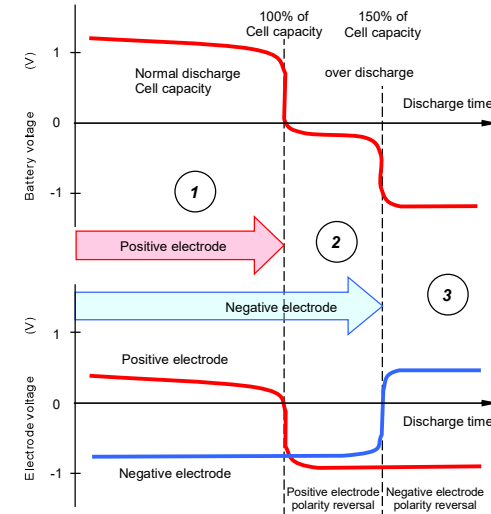

Figure 28.32. NiCd discharge polarity reversal characteristics.

vii. NiCd over discharge: When cells are connected in series and discharged completely, small cell capacity differences cause one cell to reach complete discharge first. This cell may be driven into reverse by the others. When this happens in an ordinary nickel-cadmium sealed cell, oxygen evolves at the cadmium electrode and hydrogen at the nickel electrode. The gas pressure increases if current discharge continues, eventually the cell vents. This condition is minimized by using a reducible material in the positive plates in addition to the nickel hydroxide, to suppress hydrogen evolution when the positive plate expires. Discharging to the point of reversal should be avoided.

viii. Polarity reversal during over-discharge

Most applications employ multi-cell, series connected batteries. When discharging, the lowest capacity cell will be the first to experience a voltage drop. If the battery discharge continues, this unit cell will be driven into an over-discharged condition. When the cell voltage drops below 0V, its polarity is effectively reversed. The cell reactions, at different stages, as shown in figure 28.32, are as follows:

- Stage 1: Initially, the positive and negative electrodes, as well as the discharge voltage, are normal.
- Stage 2: The active material on the positive electrode becomes completely discharged and evolution of hydrogen occurs. Cell pressure builds up. Since the battery is designed with excess negative capacity (discharge reserve), the discharge continues; discharge voltage is around -0.2V to -0.4V.
- Stage 3: The active material on both electrodes is depleted and oxygen generation starts at the negative electrode. Formation of gases at both electrodes leads to high internal cell pressure and opening of the safety vent, resulting in cell performance deterioration if this scenario occurs repeatedly.

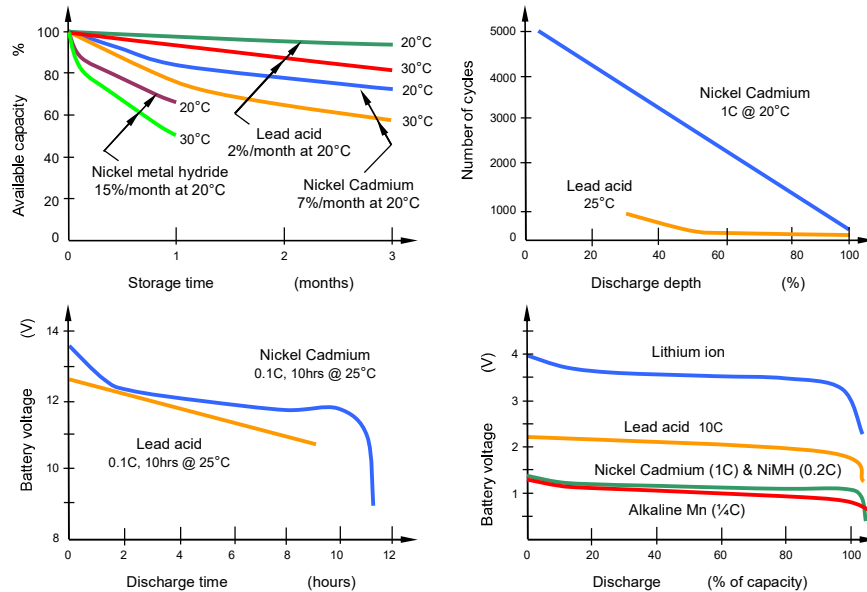

Figure 28.33. NiCd discharge characteristics: (a) capacity versus storage time; (b) cycle life versus discharge depth; (c) voltage characteristics during discharge; and (d) discharge curves for five cell types.

viii. Memory: A known NiCd limitation is the *memory effect*, where the cell retains the characteristics of the previous cycle, gradually losing its useful capacity when subjected to repeated shallow cycling without being fully discharged. The cell remembers the level of discharge and the voltage of the cell emulates that of a fully discharged cell. This causes the normally microscopic cadmium hydroxide crystals to grow large, passivating the anode electrode, or the battery to wear out. In the former case, a few cycles of discharging and charging the cell will correct the problem, but may shorten the lifetime. Deep discharge is not a discharge to zero volts, but to about 1V per cell.

Nickel-cadmium is best used for deep cycling applications, and should not be used in a standby mode since it does not like being float charged.

ix. Disposal: NiCd contains toxic metals. Furnace heat treatment recovers the cadmium and iron-nickel that can be used in steel production.

Example 28.4: NiCd battery requirement

An application requires autonomy of 3 days, but is usually only discharged to its design limit once every 2 weeks, has a normal ambient temperature of 30°C and a normal average daily load of 100W @ 48V. Determine NiCd battery requirements.

Solution

Capacity = $A \times L \times k_t \times k_d \times k_a$
 where: A = required autonomy, hours
 L = daily load, A
 k_t = temperature compensation factor (see figure 28.31a)
 k_d = compensation factor for maximum allowable depth of discharge (see figure 28.31d)
 k_a = compensation factor for ageing (see figure 28.31b)
 Autonomy period: 3 days x 24 hours = 72 hours
 Daily load is: 100W/48V = 2.1A
 Temperature compensation factor (figure 28.31a): 1/1.04 = 0.96
 Maximum allowable depth of discharge is calculated from life requirement (20 years) and number of cycles (26 per year) = 520
 Discharge depth allowable (figure 28.31d) is 90% so the factor = 1/0.9 = 1.11
 Compensation factor for ageing at +30°C (figure 28.31b): 20/18 = 1.11
 Battery capacity = 72hr x 2.1A x 0.96 x 1.11 x 1.11 = 178.8Ah
 Number of series cells required: 48V/1.2V = 40

Table 28.12: Comparison between lead-acid and nickel-cadmium battery technologies

Parameter	Lead acid	Nickel cadmium
Life: float at 25°C, occasional discharge	Lifetime and performance are inter-related Thin plate: 8-10 years Thick plate (Plante): 20 years	Lifetime is independent of performance. 20 years under float conditions.
Cycle life	VRLA is not designed for cycling. Tubular plate: 700 Flat plate: 200	Pocket cell: > 1000cycles
Reliability	Cell open circuit, unpredictable	Cell short circuit, continued but decreased battery performance.
Performance	Current over 7 times Ah capacity	Current over 15 times Ah capacity
Physical size	VRLA compact, Flooded cells three times larger	NiCd larger than VRLA and smaller flood LA cells
Water	VRLA – no water addition	Occasional water addition, yearly
maintenance	VRLA cleaning and testing	Cleaning, inspection, and occasional water additions
High temperature operation > 20°C	50% lifetime reduction for every 10°C temperature increase	20% lifetime reduction for every 10°C temperature increase
Low temperature operation < 0°C	Decreased performance and capacity. Possible plate damage.	Less performance fall off. No damage down to -30°C.
Electrical abuse	Not ripple tolerant. Over discharge can cause permanent damage.	Ripple tolerant Over charge and discharge possible
Mechanical abuse	Vibration cause shedding and capacity loss	High vibration resistance
Relative costs Initial and life cycle	Low initial cost but restricted lifetime thus reducing life cycle cost.	Higher initial cost but restricted lifetime but superior lifetime and characteristics giving lower life cycle cost.

28.5.1 Nickel-Cadmium battery properties

General nickel-cadmium battery properties are summarised in Table 28.3, illustrated in figure 28.33, and in the following points.

Advantages

- Fast and simple charge, even after prolonged storage.
- High number (over 1000) of charge/discharge cycles.
- Good load performance with recharging at low temperatures and up to 70°C.
- Not harmed by ripple current.
- Long five-year storage shelf life, in any state-of-charge, requiring priming prior to use.
- Simple storage and transportation.
- Forgiving if abused - nickel-cadmium is one of the most rugged rechargeable batteries.
- Economically priced - nickel-cadmium is lowest in terms of cost per cycle.
- Available in a wide range of sizes and performance options; most cells are cylindrical.

Limitations

- Relatively low energy density, compared with new technologies.
- Memory effect but prevented by periodically discharge/charge or by the use of pocket plate technology.
- Environmentally unfriendly since it contains toxic metals.
- Relatively high self-discharge thus needs recharging after storage.
- Over-charging causes damage.

28.6 The nickel-metal-hydride battery

Anode: Rare-earth or nickel alloys with various intermetals
 Cathode: Nickel oxyhydroxide Ni(OH)₂
 Electrolyte: Potassium hydroxide KOH 6M
 Applications: Mainly satellite application, formerly cellular phones, camcorders, emergency backup lighting, power tools, laptops, portable, electric vehicles
 Typical ratings: Specific energy density: 60 to 120 Wh/kg
 Volumetric energy density: 150 to 300 Wh/l

The original battery chemical form was nickel-hydrogen. Although hydrogen has superior anodic qualities, exploitation was restricted since nickel-hydrogen requires cell pressurization. Nickel-hydrogen not only requires high-pressure steel canisters batteries but are bulky, and cost thousands of dollars per cell. Nickel-hydrogen is used mainly for satellite applications.

Some metal alloys (hydrides such as LaNi₅ or TiNi₂) can store hydrogen atoms, which then can participate in reversible chemical reactions. In NiMH batteries, the anode consists of metal alloys, including AB₂ (A:-V, Ti; B:- Zr, Ni, plus Mn, Cr, Co, and Fe giving TiNi₂) and rare earth/nickel alloys AB₅ (A:-La, cerium, neodymium, praseodymium; B:- Ni, Mn, and Co giving LaNi₅). Metal hydride cell chemistry depends on the ability of some metals to absorb large quantities of hydrogen. These metallic alloys, termed hydrides, can provide a storage sink for hydrogen that can reversibly react in battery cell chemistry. Such metals or alloys are used for the negative electrodes. The metal hydride electrode has a theoretical capacity approximately 40% higher than the cadmium electrode used in the NiCd cell.

The positive electrode is nickel hydroxide as in NiCd cells.

Except for the anode, the NiMH cell closely resembles the NiCd cell in construction. Even the voltage is virtually identical, at 1.2V, making the cells interchangeable in many applications. Thus the sealed cell construction is a hybrid of the NiCd and NiH₂ cell structures.

The cell chemistry reactions are shown in Table 28.13.

Table 28.13: Half-cell electro-chemical equations for the Nickel-metal-hydride cell

Location		Half-Reaction (discharge)	Potential
Anode	Negative terminal	$MH_{(s)} + OH^- \rightarrow M_{(s)} + H_2O + e^-$	$E_{cell}^- = -0.83V$
Cathode	Positive terminal	$NiOOH + H_2O + e^- \rightarrow Ni(OH)_2 + OH^-$	$E_{cell}^+ = 0.52V$
Net		$NiOOH + MH_{(s)} \rightarrow Ni(OH)_2 + M_{(s)}$	$E_{cell}^o = 1.35V$

When a NiMH cell is charged, the positive electrode releases hydrogen into the electrolyte. The hydrogen in turn is absorbed and stored in the negative electrode. The reaction begins when the nickel hydroxide, Ni(OH)₂, in the positive electrode and hydroxide, OH⁻, from the electrolyte combine. This produces nickel oxyhydroxide, NiOOH, within the positive electrode, water, H₂O, in the electrolyte, and one free electron, e⁻. At the negative electrode the metal alloy, M, in the negative electrode, water, H₂O, from the electrolyte, and an electron, e⁻, react to produce metal hydride, MH, in the negative electrode and hydroxide, OH⁻, in the electrolyte. See Table 28.13 - chemical equations and figure 28.34 - transport diagram. Because heat is generated as a part of the overall chemical reaction during NiMH cell charging, the charging reaction is exothermic. As a cell is charged, the generation of heat does not accumulate if it is effectively dissipated. Extreme elevated temperatures may be experienced if a cell is excessively overcharged.

The electrolyte, which is a hydrogen absorbent aqueous solution such as potassium hydroxide, takes no part in the reaction but serves to transport the hydrogen between the electrodes.

Some of the alloy metals absorb heat when absorbing hydrogen, while others give off heat when absorbing hydrogen. Both are undesirable for a cell, since hydrogen transfer should occur without any energy transfer. The better alloys are combinations of exothermic and endothermic metals in order to achieve a zero thermal specification. The success of NiMH battery technology comes from the rare earth, hydrogen-absorbing alloys (commonly known as Misch metals) used in the negative electrode. These metal alloys contribute to the high energy density of the NiMH negative electrode thus increasing the volume available for the positive electrode.

Table 28.14: Hydrogen storage metals comparison

Material	Density	H ₂ Storage Capacity
	g/cc	g/cc
LaNi ₅	8.3	0.11
FeTi	6.2	0.11
Mg ₂ Ni	4.1	0.15
Mg	1.74	0.13
MgNi Eutectic	2.54	0.16
liquid H ₂	0.07	0.07

NiMH batteries are mostly of the rare earth-nickel type, of which LaNi₅ is representative, as shown in Table 28.14. These alloys can store six hydrogen atoms per unit structure cell giving LaNi₅H₆. The electrolyte of NiMH batteries is typically 6M KOH.

The NiMH cell cost more and has half the service life of the NiCd cell, but it also has 30% more capacity, the increased power density is theoretically 50% more, while the energy density is 40% higher. The memory effect, which was at one time thought to be absent from NiMH cells, is present if the cells are sequenced just right. The memory effect is avoided if the cell is fully discharge once every 30 cycles.

The success of nickel-metal-hydride has been driven by high energy density and the use of environmentally friendly metals.

28.6.1 Nickel-metal-hydride battery properties

i. Charging: Although a battery may be able to operate at cold temperatures, this does not mean that charging is possible under such conditions. The charge acceptance for most batteries at low temperatures is confined and it must be brought up to temperatures above 0°C for charging. Nickel-cadmium can be recharged at below 0°C provided the charge rate is reduced to $\frac{1}{10}$ C. A charger designed for NiMH batteries can also charge NiCd cells, but not the other way around, since a charger only made for NiCd batteries could overcharge a NiMH battery. Nickel-cadmium cells are endothermic on charge while both cells are physically similar, there are significant differences in behaviour on charge between the two cell types that relate to the electrochemical fact that metal hydride cells are exothermic.

The effect of temperature on charging efficiency (the increase in cell capacity per unit of charge input) is an area of difference between nickel-metal hydride and nickel-cadmium cells. Specifically charge acceptance in the nickel-metal hydride cell (as shown in figure 28.35a) decreases monotonically with rising temperature beginning below 20°C and continuing through the upper limits of normal cell

operation. This contrasts with the nickel-cadmium cell, which has a peak in charge acceptance at near room temperature. With either cell type, the drop in charge acceptance at higher temperatures remains a significant concern for cells in close proximity to heat sources or with limited cooling or ventilation. Figure 28.35b indicates that the charge acceptance efficiency for the nickel-metal hydride cell is improved as the charging rate is increased.

ii. Overcharge: Nickel Metal Hydride cells are designed with an oxygen-recombination mechanism that slows the build-up of pressure caused by overcharging. The overcharging of a cell occurs after the positive electrode

- no longer has any nickel hydroxide to react with the hydroxide from the electrolyte and
- begins to evolve oxygen.

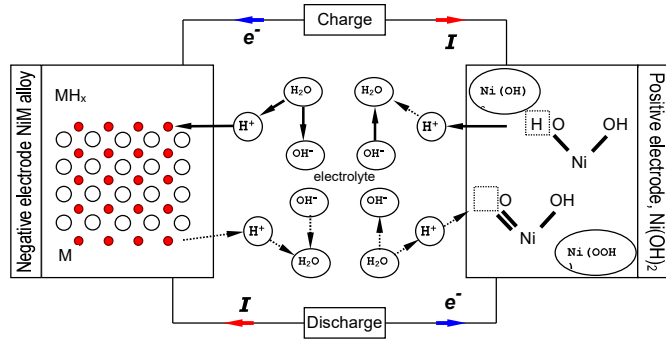

Figure 28.34. NiMH cell transport diagram for NiMH charging and discharging.

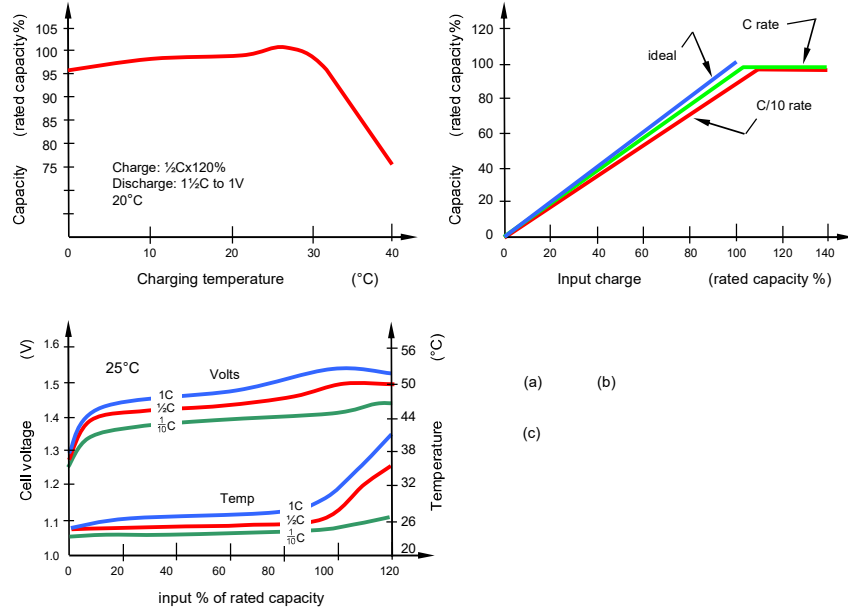
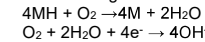

Figure 28.35. Effect of charge temperature and charge rate on charge capacity.

The oxygen diffuses through the separator where the negative electrode recombines the oxygen with stored hydrogen to form excess water in the electrolyte. If this oxygen-recombination occurs at a slower rate than the rate at which oxygen is evolved from the positive electrode, the result is in a build-up of excess oxygen gas resulting in an increase in pressure inside the cell. To protect against the first stages of overcharge, NiMH cells are constructed with the negative electrode having a capacity (or active material) greater than the positive electrode. This slows the build-up of pressure by having more active material available in the negative electrode to effectively recombine the evolved oxygen.

Excessive overcharging of a NiMH cell can result in permanent loss in capacity and cycle life. If a cell is overcharged to the level at which the pressure begins to build up, elevated temperatures are experienced causing the separator to lose electrolyte. The loss of electrolyte within the separator (or 'separator dry out') inhibits proper transport of hydrogen to and from the electrodes. Furthermore, if a cell is severely overcharged and excessive amounts of oxygen gas are evolved, the pressure may be released through the safety vent in the positive terminal. This removes elements from within the cell that are in fact needed for proper operation. To protect against the damaging effects of overcharging, specific charge terminations are used.

The oxygen recombination at the negative electrode occurs simultaneously via two reactions:



The first equation represents a direct combination of the O₂ gas with MH, which is present in significant amounts at the negative electrode of a fully charged cell. The second equation is a reverse of the electrolysis reaction that originally generated the O₂ at the positive electrode. The result of these two equations is that gaseous O₂ is reabsorbed by the negative electrode, thereby preventing unacceptably high internal pressure during the charging reactions.

iii. Discharge: When a NiMH cell discharges, the chemical reactions are the reverse of what occurs when charging. Hydrogen stored in the metal alloy of the negative electrode is released into the electrolyte to form water. This water then releases a hydrogen ion that is absorbed into the positive electrode to form nickel hydroxide. See Table 28.13 - chemical equations and figure 28.34 - transport diagram. For NiMH cells, the process of moving or transporting hydrogen from the negative electrode to the positive electrode absorbs heat and is therefore endothermic. Heat continues to be absorbed until the cell reaches a state of over discharge, where a secondary reaction occurs within the cell resulting in a temperature rise.

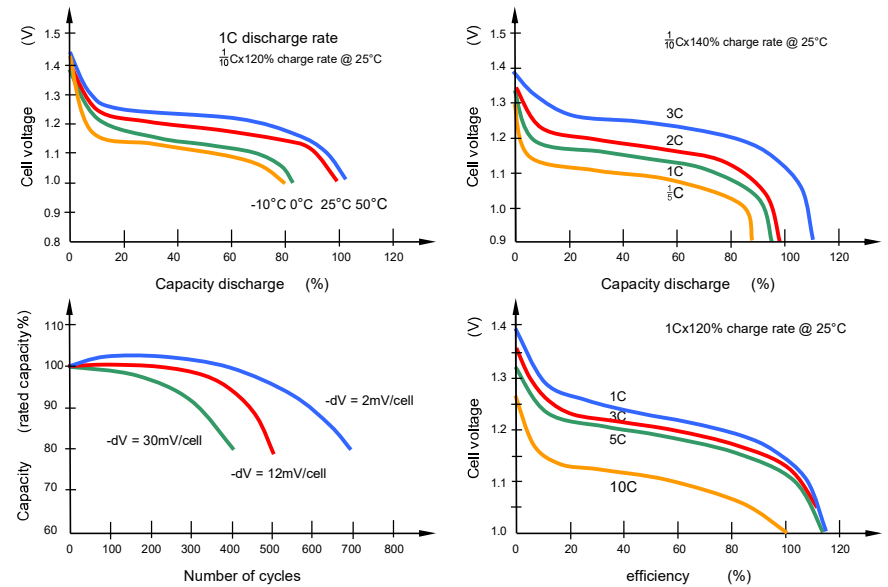

Figure 28.36. Effect of charge temperature and discharge rate on discharge capacity.

Nickel-metal-hydride is less durable than nickel-cadmium. Cycling under heavy load and operation and storage at high temperature reduces the service life and rapidly degrades performance. If charged and discharged at 45°C, the cycle life is half that at room temperature. Nickel-cadmium is also affected by high temperature operation, but to a lesser extent.

At low temperatures, the performance of all battery chemistries drops drastically, as shown in figure 28.36. While -20°C is the threshold at which the nickel-metal-hydride, sealed lead-acid and lithium-ion batteries cease to function, nickel-cadmium can go down to -40°C where it is limited to a discharge rate of $\frac{1}{5}$ C (5 hour rate).

While NiCd and Li-ion are robust and show minimal deterioration when pulse discharged, NiMH exhibits a reduced cycle life when powering a pulsed load.

Nickel-metal-hydride cells suffer from high self-discharge, higher than that of nickel-cadmium cells.

iv. Over discharge: There are two phases to the over discharging of a NiMH cell. The first phase involves the active material of the positive electrode becoming fully depleted and the generation of hydrogen gas begins. Since the negative electrode has more active material (metal hydride), it has the ability to absorb some of the hydrogen gas evolved by the positive electrode. Any hydrogen not absorbed by the negative electrode begins to build up in the cell generating pressure. The second phase begins when the entire negative electrode is fully depleted of active material. Once both electrodes are fully depleted, the negative electrode absorbs oxygen contributing to the loss of useable capacity. Extreme over discharge of a NiMH cell results in excessive gassing of the electrodes causing permanent damage in two forms. First, the negative electrode is reduced in storage capacity when oxygen permanently occupies each hydrogen storage site, and second, excess hydrogen is released through the safety vent reducing the amount of hydrogen inside the cell. To protect against the damaging effects of over discharging, proper end of discharge terminations must be used.

v. NiMH cell charging

Based on figure 33.36, NiMH battery charging is similar to that for the NiCd battery but involves slightly more complex control. A number general charging strategies have developed.

The **Two-Stage** approach uses a timer to switch from the initial charge rate to the maintenance charge rate. Because there is no sensing of the cell's transition into overcharge, the charge rate must be kept low ($\frac{1}{10}$ C) to minimize overcharge-related impact on cell performance and life. Charge durations are typically set at 16 to 24 hours to ensure full recharge in cases of complete discharge. Although economical, since this scheme makes no allowance for the degree of discharge or for environmental conditions, its use is rarely recommended for typical nickel-metal hydride cells.

A **Three-Stage** fast charge restores approximately 90 percent of the discharged capacity, an intermediate timed charge completes the charge and restores full capacity, then a maintenance charge provides a continuous trickle current to balance the cells and compensate for self-discharge. The fast charge (with currents in the 1C range) is typically switched to the intermediate charge using a temperature-sensing technique that triggers at the onset of overcharge. The intermediate charge normally consists of a $\frac{1}{10}$ C charge for a timed duration selected based on battery configuration. This intermediate-charge replaces the need to fast-charge deeply into the overcharge regime to ensure that the cell has received a full charge. Three-step charging requires greater charger complexity (to incorporate a second switch point and third charge rate) but reduces cell exposure to life-reducing overcharge.

Negative Delta Voltage NDV charging. The NiMH cell produces a small voltage drop at full charge. This Negative Delta Voltage, NDV or $-\Delta V$, is almost non-existent at charge rates below $\frac{1}{2}$ C and elevated temperatures. Aging, increased cycle count, and cell mismatch masks the already minute voltage delta, 16mV or less, which makes the use of NDV difficult for charging control. Voltage fluctuations and noise induced by the battery and charger can corrupt the NDV detection circuit if set too precisely.

Most NiMH fast chargers use a combination of NDV, voltage plateau, rate-of-temperature-increase (dT/dt), temperature threshold, and timeout timers. The charger utilizes whatever comes first to terminate the fast-charge.

NiMH batteries that use the NDV method or thermal cut-off control tend to deliver higher capacities than those charged by less aggressive methods. The gain is approximately 6 percent on a good battery. This capacity increase is gained if the battery is exposed to a brief overcharge, with the adverse consequence of a shorter cycle life. Rather than expecting 350 to 400 service cycles, the battery may be depleted within 300 cycles. Similar to NiCd charge methods, most NiMH fast-charging is based on the rate-of-temperature increase (dT/dt), with a 1°C per minute temperature raise used to terminate the charge. The absolute temperature cut-off, TCO, is 60°C. A topping charge of $\frac{1}{10}$ C is added for about 30 minutes to maximize the charge. Subsequent continuous trickle charging maintains the battery in a full charge state.

An initial fast charge of 1C is possible. Cooling periods of a few minutes are interjected when certain voltage peaks are reached. The charge then continues at a lower current. When reaching the next charge threshold, the current reduces further. This process is repeated until the battery is fully charged.

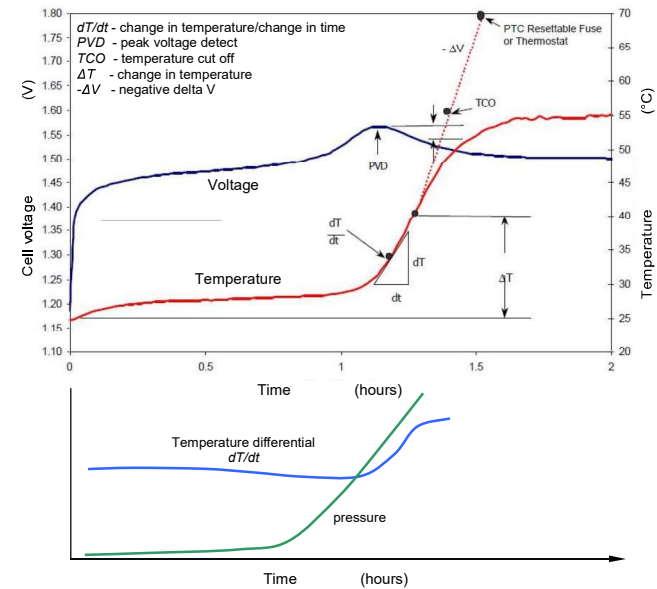

Figure 28.37. NiMH cell charge characteristics and charge termination nomenclature.

Step-differential charge is applicable to NiMH and NiCd batteries. The charge current adjusts to the SoC, allowing high current at the beginning and then moderate current towards the end of charge. This avoids excessive temperature increase towards the end of the charge cycle when the battery is less capable of accepting charge. NiMH batteries should be rapid charged rather than slow charged. The amount of trickle charge applied to maintain full charge is critical. Because NiMH does not absorb overcharge well, the trickle charge must be set lower than that for the NiCd cell. The trickle charge for the NiMH battery is a low 0.025C (C/40), hence a NiCd charger cannot be used to charge NiMH batteries, although the lower trickle charge rate is acceptable for NiCd cells.

It is virtually impossible to slow-charge a NiMH battery. At a C-rate of $\frac{1}{10}$ C and 0.3C, the voltage and temperature profiles fail to exhibit defined characteristics to measure the full charge state accurately and charging depends on a timer. Harmful overcharge can occur if a partially or fully charged battery is charged on a charger with a fixed timer. The same occurs if the battery has lost charge acceptance due to age and can only hold 50% of charge. A fixed timer that delivers a 100% charge without regard to the battery condition ultimately applies too much charge. Overcharge can occur even though the NiMH battery does not heat up.

vi. Disposal: The individual materials are mechanically separated in a vacuum to prevent any hydrogen from escaping. The nickel component is processed for use in the manufacture of stainless steel.

vii. Uses: Nickel-metal hydride has been replacing nickel-cadmium in markets such as wireless communications and mobile computing.

28.6.2 Nickel-metal-hydride battery characteristics

Most nickel-metal-hydride shortcomings are intrinsic to nickel-based technology hence are shared with nickel-cadmium. General nickel-metal-hydride battery properties are summarised in Table 28.3 and the following comparison features are based on an equivalent NiCd cell.

Advantages

- 30 to 40%, and potentially higher energy capacity than standard nickel-cadmium.
- Less prone to memory than nickel-cadmium, requiring fewer exercise cycles.
- Simple storage and non-regulatory transportation control.
- Environmentally friendly since it contains only mild toxins; profitable for recycling.

Other general advantages are

- Can be deep cycled
- Low internal impedance
- Rapid one hour charging

Limitations

- Limited service life with performance deteriorating after 200 to 300 cycles.
- Relatively short storage of three years, increasing with cooler temperature and partial charging, 40% state of charge.
- Limited discharge current, although capable of delivering high currents, heavy load reduces battery cycle life. Optimum at $\frac{1}{3}$ C to $\frac{1}{2}$ C (of rated capacity).
- Complex charging since nickel-metal-hydride generates more heat during charge and requires longer charge times than nickel-cadmium. Trickle charge settings are critical because the battery cannot absorb overcharge.
- High self-discharge, 10% in the first hour, then typically 50% higher than nickel-cadmium. Self-discharge is 50% higher than NiCd.
- High maintenance since it requires regular full discharge to prevent crystalline formation. Nickel-cadmium should be exercised monthly, nickel-metal-hydride quarterly.
- Performance degradation if not stored at cool temperatures in a 40% state-of-charge.
- Bulky, requires high-pressure steel canisters, and is expensive.

Table 28.15: Comparison between NiCd and NiMH Cells

Application Feature	Nickel-Metal Hydride and Nickel-Cadmium Batteries comparison
Nominal Voltage	Same, 1.20V
Discharge Capacity	Ni-MH up to 40% greater than NiCd
Discharge Profile	Equivalent
Discharge Cut-off Voltages	Equivalent
High Rate Discharge Capability	Effectively the same rates
High Temperature Discharge Capability	Ni-MH slightly better than standard NiCd cells
Charging Process	Generally similar; multiple-step constant current with overcharge control recommended for fast charging Ni-MH
Charge Termination Techniques	Generally similar but Ni-MH transitions are more subtle Backup temperature termination recommended
Operating Temperature Limits	Similar, but with Ni-MH, cold temperature charge limit is 15°C
Self-Discharge Rate	Ni-MH slightly higher than NiCd
Cycle Life	Generally similar, but Ni-MH is more application dependent.
Mechanical Fit	Equivalent
Mechanical Properties	Equivalent
Selection of Sizes/Shapes/Capacities	Ni-MH product line more limited
Handling Issues	Similar
Environmental Issues	Reduced with Ni-MH because of elimination of cadmium toxicity concerns

28.6.3 Comparison between NiCd and NiMH Cells

Nickel-metal hydride cells are essentially an extension of the proven sealed NiCd cell technology with the substitution of a hydrogen-absorbing negative electrode for the cadmium-based electrode. While this substitution increases the cell electrical capacity (measured in ampere-hours) for a given weight and volume and eliminates the cadmium which raises toxicity concerns, the remainder of the nickel-metal hydride cell is similar to the nickel-cadmium cell. Many application parameters vary little between the two cell types, and replacement of nickel-cadmium cells in a battery with nickel-metal hydride cells usually involves few significant design issues. Table 28.15 compares key design features between the two cell chemistries.

28.7 The lithium-ion battery

Anode:	Carbon compound, graphite
Cathode:	Cobalt-oxide/lithium-iron-phosphate/manganese-oxide
Electrolyte:	LiPF ₆ , liquid lithium salts in an organic solvent (flammable)
Applications:	Laptops, cellular phones, electric vehicles
Typical ratings:	Specific energy density: 150 to 200 Wh/kg (540 to 720 kJ/kg)
	Volumetric energy density: 250 to 550 Wh/l (1000 to 2000 MJ/m ³)
	Specific power density: 300 to 1500 W/kg, @ 20 seconds and 300 Wh/l

Lithium is the lightest metal, has the greatest electrochemical potential (Li: 0V 3850Ah/kg), and provides the largest energy density for a given weight. The ultimate battery will use the pure metal as the anode. As with NiH, the original lithium battery used pure lithium metal, thus both chemistries suffered safety limitations when used as secondary (rechargeable) energy sources. For this reason, a series of cell chemistries have been developed using lithium compounds, which are slightly lower in energy density, instead of pure highly reactive lithium metal. The positive electrode, the cathode, is typically made of lithium cobalt oxide, LiCoO₂. The negative electrode, the anode, is made of carbon. These are called generic lithium-ion batteries. The origin of the cell voltage is then the difference in free energy between Li⁺ ions intercalated in the crystal structures of the two electrode materials.

i. Cell materials

The **anode** (negative electrode) is a form of carbon mixture, graphite or, formerly, coke. All materials in a cell have a theoretical energy density. With lithium-ion, the anode has been optimized and little improvements can be gained in terms of design changes. The graphite is conductive, dilutes the lithium ion for safety, is cheap, and does not allow dendrites or other unwanted crystal structures to form. Anodes consist of a layered crystal graphite (C: 0.1V 370Ah/kg) into which the lithiated metal oxide such as LiCoO₂, LiNi_{0.3}Co_{0.7}O₂, LiNiO₂, LiV₂O₅, LiV₆O₁₃, LiMn₄O₉, LiMn₂O₄, LiNi_{0.2}CoO₂ is intercalated. Lithium titanate spinel oxide (in conjunction with manganese) nanomaterials (Li₄Ti₅O₁₂: 1.5V, 175Ah/kg, 200Wh/kg) has been introduced into the anode to eliminate lithium-ion/anode-graphite interaction, thereby providing high-power thermally stable cells with improved cycle life, increased power output, faster charge, wider temperature operating range, but at the expense of halved energy density. The higher potential offers inbuilt overcharge protection. The 'zero-strain' solid insertion material does not form a passivating interfacial layer with the solid electrolyte, resulting in a long cycle life. Other anode materials: [Li_{4.4}Si, 0.7V 4212Ah/kg, 3kWh/kg; Li_{4.4}Ge, 0.9V, 1624Ah/kg, 1.7kWh/kg] During charge, the positive material is oxidized and the negative material is reduced, where lithium ions are de-intercalated from the positive material and intercalated into the negative material. The reverse process is present during a discharge cycle.

Location	Half-Reaction (charge)
Anode	Negative terminal $C + xLi^+ + xe^- \rightarrow Li_xC$
Cathode	Positive terminal $LiXOX_2 \rightarrow Li_{1-x}XOX_2 + Li^+ + xe^-$
Net	$C + LiXOX_2 \rightarrow Li_{1-x}XOX_2 + Li_xC$

Capacity calculation on a typical anode, using Faraday's constant of 96485 coulombs/mole of electrons:

$$8Li^+ + Co_3O_4 + 8e^- \xrightleftharpoons[\text{charge}]{\text{discharge}} 4Li_2O + 3Co^0$$

$$\frac{8e^- \times 96485As}{1 \text{mole}} \times \frac{1 \text{hour}}{3600s} \times \frac{1 \text{mole}}{240.8g}$$

The anode theoretical gravimetric capacity is 0.890 Ah/g.

The **cathode** is a combination of lithium salts and other specific metals and shows promise for further enhancements. Battery research is therefore focussed on cathode variants, where Table 28.16 is a sample of the types of cathode materials used. However, the cathode is generally one of three lithium liberating compounds: a layered oxide, such as cobalt oxide, a polyanion, such as lithium iron phosphate, or a spinel, such as manganese oxide. Three typical electro-active oxide materials are

- Lithium Cobalt-oxide LiCoO_2 ,
- Lithium Manganese-oxide LiMn_2O_4 , spinel, and
- Lithium Nickel-oxide LiNiO_2 , all as shown in Table 28.16.

Doping with transition metals changes the nature of the active materials and enables the specific capacity to be regulated and internal impedance of the cell to be reduced. Cell voltages in the range 2.1V to 5V are possible.

With an iron phosphate cathode material, the battery retains the features of conventional lithium-ion batteries, but eliminates the threat of thermal runaway.

Table 28.16: Cathode chemistry active variants

Cathode Material	Average Voltage	Gravimetric Capacity - Energy		structure	Diffusion coefficient	conductivity	O ₂ evolution at overcharge/thermal runaway	Metal cost
		Ah/kg	Wh/kg					
LiCoO_2	3.7	274/140	520	hexagonal	$10^{-7}\sim 10^{-9}$	10^{-2}	yes/150	25
LiMn_2O_4 LMO	4.0	148/120	580	FC cubic (spinel)	$10^{-9}\sim 10^{-11}$	10^{-6}	no/250	1
$\text{LiCo}_{1/3}\text{Ni}_{1/3}\text{Mn}_{1/3}\text{O}_2$	3.6	-/160	580					
$\text{Li}(\text{Li}_6\text{Ni}_6\text{Mn}_7\text{Co}_2)\text{O}_{22}$ NMC	4.2	-/220	920				-/210	
LiFePO_4 LFP	3.6	-/170	570	ordered olivine			-/270	
$\text{Li}_2\text{FePO}_4\text{F}$	3.6	-/115	420	octahedra				
LiNiO_2	3.5	275/150	630	hexagonal	$10^{-7}\sim 10^{-9}$	10^{-1}	yes/-	4
CuF_2	3.6	-/520	1875					
$\text{Li}_2\text{NiSiO}_4$	4.7	-/320	1550					

Lithium Nickel Cobalt Aluminium Oxide ($\text{Li}(\text{Ni}_x\text{Co}_y\text{Al}_{1-x-y}\text{O}_2)$) **NCA**
 Lithium Titanate $\text{Li}_4\text{Ti}_5\text{O}_{12}$ **LTO**

Table 28.17: Comparison of cobalt and manganese as positive electrodes

	Cobalt LiCoO_2	Manganese (Spinel) LiMn_2O_4
Energy density	140 Wh/kg	120 Wh/kg
Safety	On overcharge, the cobalt electrode provides extra lithium, which can form into metallic lithium, causing a potential safety risk if not protected by a safety circuit.	On overcharge, the manganese electrode runs out of lithium causing the cell to warm. No safety circuits for smaller cell numbers.
Temperature	Wide temperature range. Best suited for operation at elevated temperature.	Capacity loss above +40°C. Not as durable at higher temperatures.
Aging	Short-term storage possible. Impedance increases with age. Newer versions offer longer storage.	Slightly less than cobalt. Impedance changes little over the life of the cell. Due to continuous improvements, storage time is difficult to predict.
Life Expectancy	300 cycles, 50% capacity at 500 cycles.	Shorter than cobalt.
Cost	Raw material relatively high; protection circuit adds to costs.	Raw material 30% lower than cobalt. Cost advantage due to simplified protection circuit.

Another cell part that has development potential is the **electrolyte**. The electrolyte serves as a reaction medium between the anode and the cathode. It acts as an ion conducting media, blocks electrons, and does not take part in the chemical reaction.

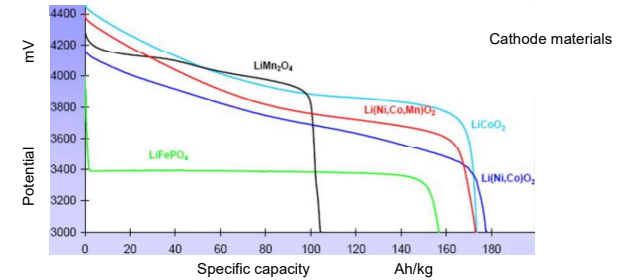

Figure 28.38. Comparison of cathode materials.

Table 28.18. Lithium salts as electrolyte solutions

salt	Mole wt	T _{decomposition}	A _t corrosion	Conductivity	Conductivity
				σ	σ
		°C in solution		1M@25°C	EC/DMC
				mS/cm	mS/cm
LiBF_4	93.9	>100	N	3.4	4.9
LiBF_6	151.9	>80	N	5.8	10.7
LiAsF_6	195.9	>100	N	5.7	11.1
LiClO_4	106.4	>100	N	5.6	8.4
Li Triphlate	155.9	>100	Y	1.7	
Li Imide	286.9	>100	Y	5.1	9.0

Electrolyte

Liquid or gel electrolytes in Li-ion batteries consist of solid lithium-salt electrolytes, such as LiPF_6 , (although this has a problem with aluminium corrosion), LiBF_4 , or LiClO_4 , and liquid organic solvents, such as ether. The exact composition of the non-aqueous solvents varies (see Table 28.18), but propylene carbonate (PC) – dimethyl ether is used for primary cells and ethylene carbonate (EC) with linear organic carbonates such as dimethyl carbonate (DMC), diethyl carbonate, and ethylmethyl carbonate are used in secondary cells. A liquid electrolyte conducts Li ions, which act as a carrier between the cathode and the anode when a battery produces an electric current through an external circuit. However, solid electrolytes and organic solvents are easily decomposed on the highly reactive anodes during charging, thus preventing battery activation. Nevertheless, when appropriate organic solvents are used for electrolytes, they are decomposed and form a solid electrolyte anode passivation interface layer (solid electrolyte interface) at first charge that is electrically insulating and imposes resistance to Li-ion conduction. The interface prevents decomposition of the electrolyte after the second charge but the layer limits the discharge rates and renders the battery unchargeable at low cold temperatures. For example, microporous polyethylene membranes such as ethylene carbonate, are decomposed at a relatively high voltage, (in contrast to only 0.7V for lithium), and forms a dense and stable interface, which separate the electrons from the ions. The electrolyte interface breaks down at about 120°C, at which temperature the highly reactive anode reacts with the electrolyte, producing excessive heat in a thermally runaway process.

Since lithium reacts with water, the electrolyte is a non-aqueous organic lithium salt. Thus, unlike the lead-acid cell that uses water, no hydrogen or oxygen gases are produced by the Lithium-ion cell. Depending on the choice of material for the anode, cathode, and electrolyte, the voltage, capacity, life, and safety of a lithium-ion battery can vary dramatically. Adding more nickel in lieu of cobalt increases the ampere/hours rating and lowers the manufacturing cost but makes the cell less stable.

ii. Construction

As with most batteries there is an outer case made of a non-reactive metal. The use of metal is particularly important because the battery is pressurized. This metal case has a pressure-sensitive vent hole. If the battery ever gets so hot that it risks exploding from over-pressure, this vent releases the excess pressure. The battery becomes ineffective, so venting is to be avoided. The vent is a safety measure, as is a resettable terminal Positive Temperature Coefficient (PTC) switch, which prevents the battery from overheating.

This cell chemistry and construction permits very thin separators between the electrodes that are made with high surface areas. This enables the cells to handle the high current rates necessary in high power applications.

The metal case holds a long spiral comprising three thin sheets pressed together, not unlike a capacitor:

- A positive electrode
- A negative electrode
- A separator

The sheets are immersed in an organic solvent like ether that acts as the electrolyte. The separator is a thin sheet of microperforated polyethylene plastic, which separates the positive and negative electrodes while allowing ions to pass, but blocks internal electron migration.

Spiral Wound Cylindrical Cell

In order to increase current carrying capacity, it is necessary to increase the active surface area of the electrodes, however the cell case size sets limits on the size of electrodes which can be accommodated. One way of increasing the electrode surface area is to make the electrodes and the separator from long strips of foil and roll them into a spiral cylindrical shape. This provides low internal resistance cells. But since the electrodes take up more space within the can there is less room for the electrolyte and so the potential energy storage capacity of the cell is reduced. This construction is used extensively for secondary cells. Figure 28.39 shows a Lithium-ion cell but this technology is also used for NiCd, NiMH and even some Lead-acid secondary cells designed for high rate applications.

A spiral wound construction is not limited to cylindrical shapes. The electrodes can be wound onto a flat mandrel to provide a flattened shape, which can fit inside a prismatic case. The cases may be made from aluminium or steel. This capacitor type of construction is ideally suited for production automation.

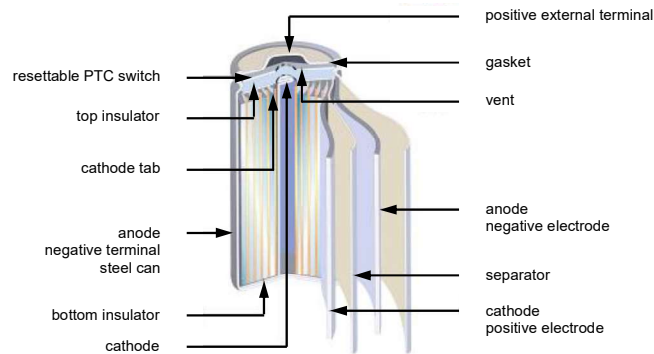

Figure 28.39. Spiral Cylindrically Wound Electrodes.

28.7.1 Cathode variants cells

i. The Lithium-Cobalt oxide Cell - LiCoO₂

As shown in Table 28.16, the lithium-cobalt oxide cell voltage is typically 3.7V to 3.9V, and the half-cell reactions are shown in the following table.

Location		Half-Reaction (charge)
Anode	Negative terminal	$C_6Li + xLi^+ + xe^- \rightarrow C_6Li_{1+x}$
Cathode	Positive terminal	$LiCoO_2 \rightarrow Li_{1-x}CoO_2 + xLi^+ + xe^-$
Net		$C_6Li + LiCoO_2 \rightarrow Li_{1-x}CoO_2 + C_6Li_{1+x}$

Most lithium-ion batteries for portable applications are cobalt-based. The cell system consists of a cobalt oxide positive electrode (cathode) and a graphite carbon as the negative electrode (anode). Figure 28.40a illustrates the layered crystalline structure of cobalt oxide. An advantage of the cobalt-based battery is its high energy density, typically 140Ah/kg and energy of 500Wh/kg. A long run-time makes this chemistry attractive for cell phones, laptops, and cameras.

The widely used cobalt-based lithium-ion has drawbacks; it offers a relatively low discharge current. A high load would overheat the pack, jeopardizing its safety. The safety circuit of the cobalt-based battery typically limits the charge and discharge rate to about 1C. Another drawback is the internal resistance increase that occurs with cycling and ageing. After 2 to 3 years of use, the battery often becomes unserviceable due to a large voltage drop under load caused by a high internal resistance. The use of cobalt is unfortunately associated with environmental and toxic hazards.

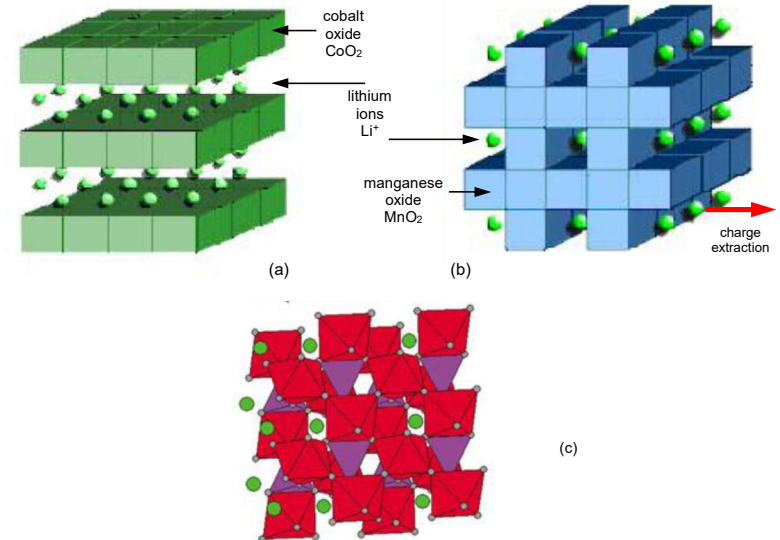
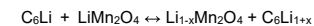

Figure 28.40. Cathode (positive electrodes) crystalline structures where during discharge, the lithium ions (shown in green) extracted from the cathode and are inserted in the anode: (a) layered cobalt oxide structure with the lithium ions shown bound to the cobalt oxide, (b) three-dimensional framework lithium manganese oxide structure. This spinel structure, which is usually composed of diamond shapes connected into a lattice, appears after initial formation; giving high conductivity but lower energy density. The lithium-ion flow reverses on cell charge, and (c) olivine structure of LiFePO₄.

ii. The Lithium-Manganese oxide Cell - LiMn₂O₄

Lithium manganese oxide (LMO), termed spinel, used as a cathode material, produces a 4V cell voltage with an energy density of better than 100Ah/kg and energy of 580Wh/kg. This substance forms a three-dimensional spinel structure that improves the lithium ion flow between the electrodes, as shown in figure 28.40b. High ion flow lowers the internal resistance and increases current capability. The resistance remains low with cycling, however, the cell does age and the overall service life is similar to that of lithium-cobalt. Spinel has an inherently high thermal stability and needs simpler cell safety circuitry than a lithium-cobalt battery. The low internal cell resistance characteristic benefits fast-charging and high-current discharging. A spinel-based lithium-ion cell has ten times the current capability of the equivalent volume lithium-cobalt cell, with marginal heat build-up. One-second current pulses of twice the specified current are permissible. Some heat build-up cannot be prevented and the cell temperature should not exceed 80°C.



One significant drawback of the spinel cell is the lower energy capacity, approximately half, compared to the cobalt-based cell. But spinel still provides an energy density that is about 50% higher than that of a nickel-based equivalent.

Manganese, unlike Cobalt, is a safe and more environmentally benign cathode material.

iii. The **Lithium-nickel-cobalt-manganese Cell** – Li(NiCoMn)O₂

The tri-element cathode incorporates nickel, cobalt, and manganese (NCM) in the crystal structure that forms a multi-metal oxide material to which lithium is added. It is not possible to achieve a high energy density and high load capability in the same package; there is a compromise between the two. A NCM cell charges to 4.10V/cell, 100mV less than cobalt and spinel. Charging to 4.20V/cell provides higher capacities but the cycle life is more than halved, from 800 cycles to about 300.

iv. The **Lithium-Phosphate Cell** - LiFePO₄

Nano-phosphate materials are added to the cathode -LFP, (shown in figure 28.40c), resulting in the highest power density in W/kg and energy density of 170Ah/kg, of any lithium-ion battery. The cell can be continuously discharged to 100% depth-of-discharge at 35C and can endure discharge pulses up to 100C. The phosphate-based system has a nominal voltage of about 3.3V/cell and the peak charge voltage is 3.6V. This is lower than the cobalt-based lithium-ion, hence requires a dedicated charger. Phosphate based technology possesses superior thermal and chemical stability which provides better safety characteristics than those of lithium-ion cathode technologies. Lithium phosphate cells are incombustible during charge or discharge, more stable under overcharge or short circuit conditions, and withstand high temperatures without decomposing. When abused, the phosphate based cathode material does not burn and is not prone to thermal runaway. Phosphate chemistry also offers a longer cycle life.

v. The **Lithium-Polymer Cell**

The most economical lithium-ion battery in terms of cost-to-energy ratio is cylindrical. Such cells are used for mobile computing and other applications that do not demand an ultra-thin prismatic (rectangular) geometry. If a slim pack is required, the prismatic lithium-polymer cell or alternatively the lithium-ion polymer cell, are the best choices but come at a higher cost in terms of stored energy. The lithium-polymer differentiates itself from conventional battery systems in the type of electrolyte used, as shown in figure 28.41. The lithium-polymer electrochemistry uses active materials such as LiCoO₂, LiNiO₂ and its Co doped derivatives, but generally not LiCoO₂ chemistry. The dry solid polymer electrolyte resembles a plastic-like film that does not conduct electricity but allows ion exchange (electrically charged atoms or groups of atoms). The polymer electrolyte replaces the traditional porous separator, soaked with electrolyte. The dry solid polymer cell depends on heat to enable sufficient ion flow. This requires that the battery core be kept at an operation temperature above room temperature, 60°C to 100°C.

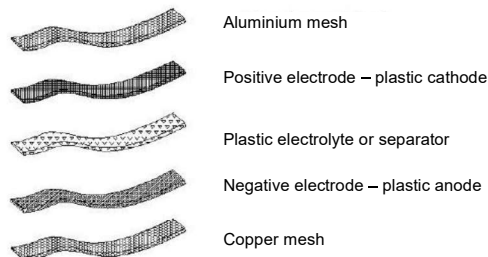
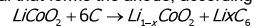
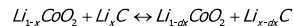

Figure 28.41. Lithium polymer cell construction layers.

When lithium polymer cells are first charged, lithium ions are transferred from the layers of the lithium cobaltite to the carbon material that forms the anode, according to:



Subsequent discharge and charge reactions are based on the motion of lithium ions Li⁺ between the insertion anode and cathode electrodes.



The dry polymer design offers simplifications with respect to fabrication, ruggedness, long life, safety and thin-profile geometry (flexible form factor), but it is expensive. Unfortunately, the dry lithium-polymer suffers from poor conductivity. To compromise, some gelled electrolyte is added. Cells have a separator/electrolyte membrane with the porous polyethylene or polypropylene separator filled with a polymer, which gels (plasticizes) upon filling with the liquid electrolyte. Thus, the commercial lithium-ion polymer cells are similar in chemistry and materials to their liquid electrolyte counter parts.

With a cell thickness measuring less than a millimetre, virtually no restrictions exist in terms of cell form, shape, and size. Lithium-ion-polymer finds its market niche in lightweight, wafer-thin, flexible form-factor geometries, such as batteries for credit cards and other such applications. It is more stable and resistant to over-charge, but is expensive, has a lower energy density, discharge rate and cycle count than lithium-ion, but longer storage life.

Advantages and Limitations of Li-ion Polymer Batteries

Advantages

- Low profile - batteries that resemble the profile of a credit card are feasible.
- Flexible form factor - manufacturers are not bound by standard cell formats.
- With high volume, any reasonable size can be produced economically.
- Light weight - gelled rather than liquid electrolytes enable simplified packaging, in some cases eliminating the metal shell.
- Improved safety - more resistant to overcharge; less chance for electrolyte leakage.

Limitations

- Lower energy density and decreased cycle count compared to Li-ion - potential for improvements exist.
- Expensive to manufacture - once mass-produced, the Li-ion polymer has the potential for lower cost. Reduced control circuit offsets higher manufacturing costs.

Table 28.19 highlights a number of other alternative lithium-ion cell cathode types.

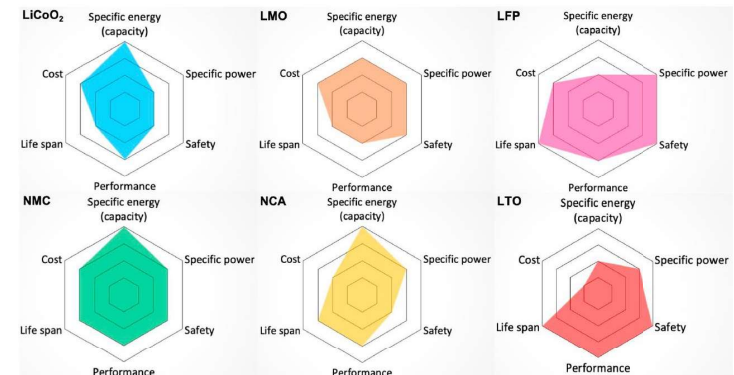

Comparison of different Li-ion battery technologies in terms of: specific energy (capacity), specific power, safety, performance, life span, and cost. See Table 28.16 for cathode abbreviations.

28.7.2 General Lithium-ion cell characteristics

Lithium-ion load characteristics are similarly to nickel-cadmium in terms of discharge. The high cell voltage of 3.6V allows battery pack designs with only one cell. Most mobile phones use a single cell. Lithium-ion is a low maintenance battery, an advantage that most other chemistries cannot claim. There is no memory and no scheduled cycling is required to prolong battery life. In addition, the self-discharge is less than half that of nickel-cadmium. Lithium-ion has drawbacks; specifically it is fragile and requires a protection circuit to maintain safe operation, as considered in section 28.7.4.

i. Discharge: Lithium-ion should function within the discharge temperature limits of -20°C to 60°C. Cell performance is temperature based, meaning that the rate capability at or below -20°C is reduced due to increased electrolyte impedance. Discharging at low temperatures does not harm the battery. Lithium-ion may be used down to -30°C with acceptable results. A high discharge rate combined with elevated temperatures above 60°C can cause self-heating, an effect that could permanently damage the separator and electrodes of the cells. Cells perform better on a pulse rather than dc load. The dc resistance of a cylindrical cell is approximately 110mΩ. At 1kHz ac, the impedance reduces to about 36mΩ. As the pulse frequency increases, the cell's effective impedance reduces. This results in better performance and lower heat build-up, consequently increasing lithium-ion cell life.

The internal resistance of cobalt-based lithium-ion increases with age. A manganese-based cell maintains its resistance at a low level throughout its service life. Although the cobalt-based lithium-ion cell has a higher energy density, manganese is better suited for pulse load applications.

ii. **Li ion cell recharging:** A moderate charge and discharge puts less stress on the battery, resulting in a longer cycle life, as shown in figure 28.42.

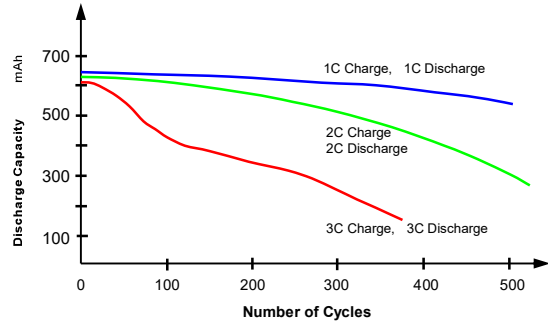

Figure 28.42. Cycle/Lifetime of a lithium-ion cell as a function of charge and discharge rates.

Li-ion cell charging is voltage-limited similar to lead acid battery charging. The difference lies in a higher voltage per cell, tighter voltage tolerance, and the absence of trickle or float charge at full charge.

While the lead acid battery offers some flexibility in terms of voltage cut-off, Li-ion cells are strict on the correct charging cut-off voltage. Although higher cut-off voltages deliver increased energy densities, cell oxidation severely limits service life. Aided by chemical additives, Li-ion cells are charged to 4.20V, with a tolerance of $\pm 50\text{mV/cell}$. For maximum cycle life, an end-of-charge voltage threshold of about 3.90V/cell is used.

The charge time of all Li-ion batteries, when charged at a 1C initial current, is about 3 hours with about a 70% charge level being reached, during which time the battery remains cool. This charge state is often referred to as fast charging. Full charge is attained after the voltage has reached the upper voltage threshold and the current has dropped and levelled off to about 3 percent of the nominal charge current. Although the voltage peak is reached quicker with higher current, the topping charge takes twice as long as the initial charge. Figure 28.44 shows the voltage and current charging profile as the Li-ion cell passes through stages one and two.

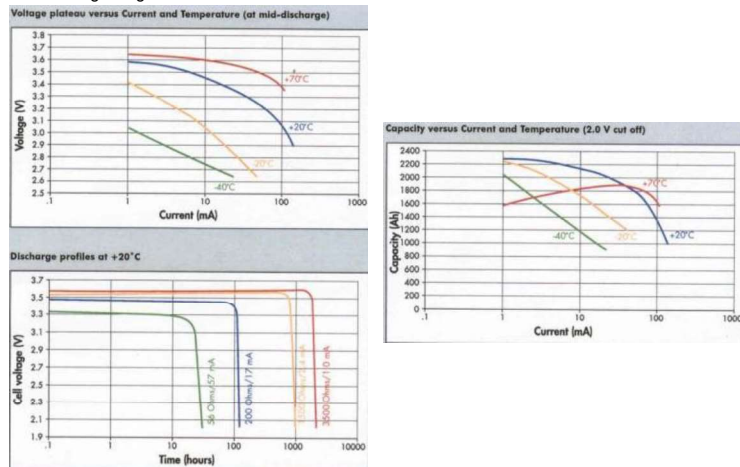

Figure 28.43. Li-ion cell capacity factors.

Table 28.19: Lithium-ion chemistries

Chemistry	Cathode	Electrolyte	Nominal voltage	Open-circuit voltage	Wh/kg	Wh/dm ³
Li-MnO ₂ (Li-Mn)	Heat-treated manganese dioxide	Lithium perchlorate in propylene carbonate and dimethoxyethane, M Wt 106.4	3V	3.7V	280	580
	About 80% of the lithium battery market. Uses inexpensive materials. Suitable for low-drain, long-life, low-cost applications. High energy density per mass and volume, 650Wh/l. Can deliver high pulse currents. Wide temperature range -40°C to 60°C, max. With discharge the internal impedance rises and the terminal voltage decreases.					
Li-SOCl ₂	Thionyl chloride	Lithium aluminium chloride in thionyl chloride	3.5V	3.65V	290	670
	Liquid cathode. Can operate down to -55°C, where it retains over 50% of its rated capacity. Negligible gas generated in nominal use, limited amount under abuse. Relatively high internal impedance and limited short-circuit current. High energy density, about 500Wh/kg. Toxic. Electrolyte reacts with water. After storage can form anode passivation layer, which leads to temporary voltage delay when first put into service. High cost and safety concerns. Can explode when shorted. Hazardous waste.					
Li-SOCl ₂ , BrCl, Li-BCX	Thionyl chloride with bromine chloride	Lithium aluminium chloride in thionyl chloride	3.75V	3.9V	350	770
	Liquid cathode. A variant of the thionyl chloride battery, with 300 mV higher voltage, which quickly drops back to 3.5V, as the bromine chloride is consumed during the first 10-20% of discharge. Added bromine chloride improves safety when abused. Wide temperature range -55°C to 80°C. 1420Wh/l.					
Li-SO ₂ C ₂	Sulphuryl chloride		3.7V	3.95V	330	720-1400
	Liquid cathode. Similar to thionyl chloride. Discharge does not result in build-up of elemental sulphur, which is involved in some hazardous reactions, therefore is safer. The electrolyte tends to corrode the lithium anodes, reducing the shelf life. Chlorine is added to some cells to make them more resistant to abuse. Sulphuryl chloride cells give less maximum current than thionyl chloride, due to polarization of the carbon cathode. Sulphuryl chloride reacts violently with water, releasing hydrogen chloride and sulphuric acid.					
Li-SO ₂	Sulphur dioxide on teflon-bonded carbon	Lithium bromide in sulphur dioxide with small amount of acetonitrile	2.85V	3.0V	250	400
	Liquid cathode. Can operate down to -55°C and up to +70°C. Contains liquid SO ₂ at high pressure. Requires safety vent, can explode in some conditions. High energy density 440Wh/l. High cost. At low temperatures and high currents performs better than Li-MnO ₂ . Toxic. Acetonitrile forms lithium cyanide, and can form hydrogen cyanide in high temperatures. Addition of bromine monochloride can boost the voltage to 3.9V and increase energy density.					
Li-(CF) _x	Carbon monofluoride	Lithium tetrafluoroborate in propylene carbonate, dimethoxyethane, and/or gamma-butyrolactone	2.8V	3.1V	360	680
	Cathode material formed by high-temperature intercalation of fluorine gas into graphite powder. High energy density (250Wh/kg), 7 year shelf life. Used for low to moderate current applications, e.g. memory and clock backup batteries. Maximum temperature 85°C. Low self-discharge (<0.5%/year at 60°C, <1%/yr at 85°C).					
Li-Ag ₂ CrO ₄	Silver chromate	Lithium perchlorate solution	3.1/2.6 V	3.45 V		
Li-FeS ₂	Iron disulphide	Propylene carbonate, dioxolane, dimethoxyethane	1.5V	1.8V	297	320
	'Lithium-iron', 'Li/Fe'. Called 'voltage-compatible' lithium. 2.5 times higher lifetime for high current discharge regime than alkaline batteries, no advantage for low-current applications. Low self-discharge, 10 years storage time. FeS ₂ is cheap. Some types rechargeable. Cathode often designed as a paste of iron sulphide powder mixed with powdered graphite. 370Wh/l. Variant is Li-CuFeS ₂ . 2Li+FeS ₂ →Li ₂ FeS ₂ then 2Li+Li ₂ FeS ₂ →Fe+2Li ₂ S					
Li-V ₂ O ₅	Vanadium pentoxide		3.3/2.4V	3.4V	120/260	300/660
	Two discharge plateaus. Low-pressure. Rechargeable. Used in reserve batteries. LiAl anode					

No trickle charge is applied because Li-ion is unable to absorb overcharge. Trickle charge causes plating of metallic lithium, rendering the cell unstable. Instead, a brief topping charge is applied to compensate for the small amount of self-discharge the battery and its protective circuit consume. A topping charge may be implemented once every 500 hours or 20 days. Typically, when the open terminal voltage drops to 4.05V/cell and ceases when 4.20V/cell is reached again. On a charge voltage above 4.30V, Li-ion cells become increasingly unstable with lithium metal plated on the anode, and, the cathode material becomes an oxidizing agent, loses stability, generates heat, and releases oxygen. Li-ion battery packs contain a protection circuit that prevents the cell voltage from going too high while charging. The typical safety threshold is set to 4.30V/cell. In addition, temperature sensing disconnects the charge source if the internal temperature approaches 90°C. Most cells feature a mechanical pressure switch that permanently interrupts the current path if a safe pressure threshold is exceeded. Internal voltage control circuits cut off the battery at low and high voltage levels.

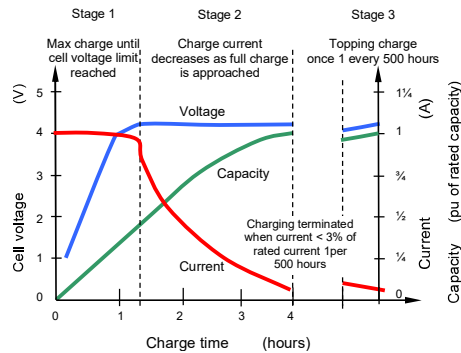

Figure 28.44. Charge stages of a Li-ion battery.

Increasing the charge current does not significantly shorten the charge time.

Although the voltage peak is reached quicker with higher current, the topping charge takes longer.

Exceptions are made on spinel (manganese) batteries. On overcharge, this chemistry produces minimal lithium plating on the anode because most metallic lithium has been removed from the cathode during normal charging. The cathode material remains stable and does not generate oxygen unless the cell gets extremely hot.

iii. Lithium Polymer cell charging

The charge process of a Li-Polymer cell is similar to that of the Li-ion cell. Li-Polymer uses dry electrolyte and takes 3 to 5 hours to charge. Li-ion polymer with gelled electrolyte, on the other hand, is almost identical to that of Li-ion, such that the same charge algorithm can be applied. With most chargers, the user does not need to know whether the battery being charged is Li-ion or Li-ion polymer. Most 'Polymer' batteries are a variety of the Li-ion polymer using some sort of gelled electrolyte. Low-cost dry polymer batteries for ambient temperature operation are evolving.

The charge cycle, called a CC/CV two-stage charge cycle, is necessary to fully charge the battery.

- The first stage of the charge cycle is a Constant Current charge until the battery voltage reaches 4.1 to 4.2V.
- Upon reaching this peak voltage, a Constant Voltage charge is initiated until the charge current reduces to 3% of the rated current. Upon charge completion, a top-off charge may be used to counteract the self-discharge of the battery and protective circuit. This top-off charge may be initiated when the battery open circuit voltage reaches less than 4.05 volts and terminates upon reaching the full charge voltage of 4.1 to 4.2V. Depending on the battery, this top off charge may be repeated once every 20 days.

iv. Battery float voltage

The main determining factor of a battery's float voltage is the electrochemical potential of the active materials used in the battery's cathode, which for lithium is approximately 4V. The addition of other compounds can change this voltage. A second factor is a trade off between cell capacity, cycle life, battery life, and safety. The curve in figure 28.45a shows the relationship between cell capacity and cycle life.

The best compromise between capacity and cycle life of a standard Li-ion cell is a 4.2V float voltage. Using 4.2V as the constant voltage limit (float voltage), a battery can typically deliver about 500 charge/discharge cycles before the battery capacity drops to 80%. A lower float voltage for Li-ion phosphate batteries results in a much higher number of charge/discharge cycles. One charge cycle consists of a full charge to a full discharge. Multiple shallow discharges add up to one full charge cycle.

Although charging to a capacity less than 100% using either a reduced float voltage or minimum charge current termination results in an initial reduced battery capacity, as the number of cycles increases beyond 500, the battery capacity with the lower float voltage can exceed that with a higher float voltage. Figure 28.45b illustrates this; how the recommended float voltage compares with a reduced float voltage in regard to capacity and the number of charge cycles.

Because of the different Li-ion battery chemistries (as in figure 28.45c for example) and other conditions that can affect battery life, the curves shown only estimate of the number of charge cycles and battery capacity levels, due to differences in battery materials and construction methods.

Battery manufacturers specify a charge method and a float voltage to meet the battery specifications for capacity, cycle life and safety. Many batteries include a battery pack protection circuit, which temporarily opens the battery connection if the maximum battery voltage is exceeded. Once opened, connecting the battery pack to the charger normally resets the pack protection. The printed battery voltage, such as 3.6V for a single cell battery, is not the float voltage, but rather the average battery voltage when discharging.

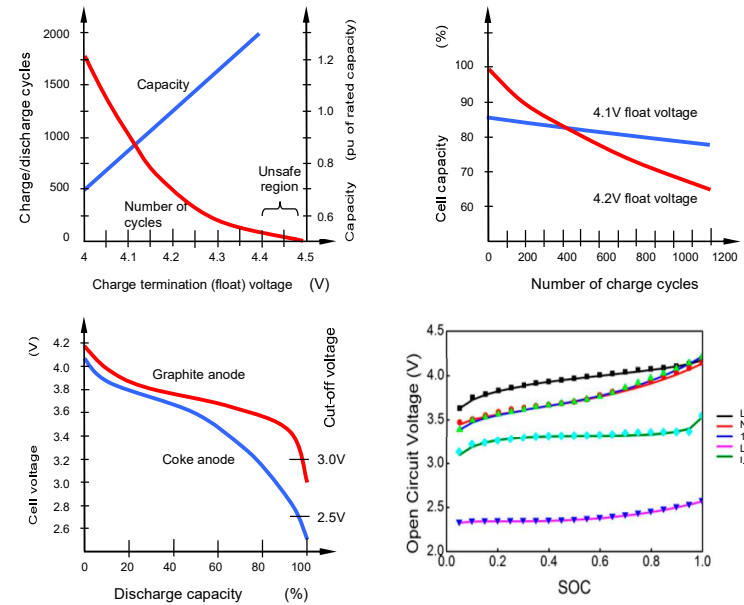

Figure 28.45. Li-ion charge float voltage and SOC characteristics.

v. **Agging:** Some capacity deterioration is noticeable after one year, whether the Lithium-ion battery is in use or not. Over two to three years, the battery frequently fails. Other chemistries also have age-related degenerative effects. This is especially true for the NiMH if exposed to high ambient temperatures. Storage in a cool place slows the ageing process of all chemistries. For lithium-ion, manufacturers recommend storage temperatures of 15°C and a 40% partial charge.

The permanent capacity loss is not recoverable by charging. This loss is linked to battery life because when the permanent capacity loss drops to approximately 80%, the battery is considered at the end of its life. Permanent capacity loss is mainly due to the number of full charge/discharge cycles, the battery voltage, and battery temperature. The longer the battery remains near 4.2V or 100% charge level (lower voltage for Li-ion Phosphate) the faster the capacity loss occurs. This is true whether the battery is being charged or floating in a fully charged condition with the voltage near 4.2V. Maintaining a Li-ion battery in a fully charged condition shortens its lifetime. The chemical changes that shorten the battery lifetime are accelerated by high float voltage and high temperature. Permanent capacity loss is unavoidable, but may be minimised by using the following techniques.

- Use partial discharge cycles. Using only 20% or 30% of the battery capacity before recharging extends cycle life considerably. Generally, 5 to 10 shallow discharge cycles are equal to one full discharge cycle. But keeping the battery in a fully charged state also has an effect on shortening battery life. Full discharge cycles should be avoided.
- Avoid charging to 100% capacity, by using a lower float voltage. Reducing the float voltage increases cycle life and service life at the expense of reduced battery capacity. A 100mV to 300mV drop in float voltage can increase cycle life by more than five times. Li-ion cobalt chemistries are more sensitive to a higher float voltage than other chemistries. Li-ion phosphate cells have a lower float voltage than the more common Li-ion batteries.
- Select the correct charge termination method. Selecting a charger that uses minimum charge current termination ($\frac{1}{10}C$) can also extend battery life by not charging to 100% capacity. For example, ending a charge cycle when the current drops to $\frac{1}{10}C$ is similar to reducing the float voltage to 4.1V. In both instances, the battery is charged to approximately 85% of capacity, which can significantly increase overall battery life.
- Limit battery temperature. High temperatures accelerate chemical changes within the battery, which shorten battery life, while charging below 0°C promotes metal plating at the battery anode, which can develop into an internal short, producing heat and making the battery unstable and unsafe. Many battery chargers have provisions for measuring battery temperature to assure charging does not occur at temperature extremes.
- Avoid high charge and discharge currents as they reduce cycle life. High currents place excessive stress on the battery. Some chemistries are more suited for higher currents such as Li-ion manganese and Li-ion phosphate.
- Avoid deep discharges below 2V or 2.5V, which quickly and permanently damage a Li-ion battery. Internal metal plating occurs causing a short circuit making the battery unusable and unsafe. Most Li-ion batteries have electronic circuitry within the battery pack that opens the battery connection if the battery voltage is less than 2.5V, exceeds 4.3V or if the battery current when charging or discharging exceeds a predefined threshold.

vi. **Disposal:** Lithium-ion cells cause little harm when disposed. Heat treatment, pyrolysis, is used to recover the primary metals.

28.7.3 General Lithium-ion cell properties

General battery properties for the lithium-ion types are summarised in Table 28.20, as follow.

Advantages

- High, ever increasing energy density and high cell voltages, 3.6V.
- Does not need prolonged priming when new. Only one regular charge is needed.
- Relatively low self-discharge, that is less than half that of nickel-based batteries.
- Low maintenance since no periodic discharge is needed
- There is no memory, so no need for fully discharging before charging.
- Specialty cells can provide high current, 40C rates.
- High number of charge/discharge cycles, with fast charging.
- Light since a light metal, lithium, is used.
- Float or trickle charging not necessary.

Limitations

- Needs protection circuit to maintain voltage, current, and temperature within safe limits.
- Higher internal impedance than other competing cell technologies.
- Subject to ageing, even in storage, 15°C storage at 40% charge minimises ageing.
- Transportation restrictions, subject to regulatory control.
- Expensive to manufacture being about 40% higher in cost than nickel-cadmium.
- Metals and chemicals are continuing changing.
- Rapid degradation with temperature increase.
- Cannot be recharged at low temperatures (below 0 to -10°C)

Table 28.20: Lithium-ion battery characteristics

Cathode material	advantages	disadvantages
Lithium cobalt oxide	High capacity	Lower charge and discharge rates Higher cost
Lithium manganese oxide	Lower ESR Higher charge and discharge rates Higher temperature operation Inherently safer	Lower capacity Lower life cycle Shorter lifetime
Lithium phosphate	Very low ESR Very high charge and discharge rates High temperature operation Inherently safer	Lower discharge voltage Lower float voltage Lower capacity

28.7.4 Cell protection circuits

Built into each battery pack, the protection circuit limits the peak voltage of each cell during charge and prevents the cell voltage from dropping too low on discharge. In addition, the cell temperature is monitored to prevent operation at temperature extremes. The maximum charge and discharge current is limited to between 1C and 2C. With these precautions in place, the possibility of metallic lithium plating occurring due to overcharge is virtually eliminated.

As with fuel cell and double layer capacitor systems, the Li-ion battery cell safety circuit consists of four main sections:

i. **Over-charge protection:** The controller monitors each cell (or paralleled cells) voltage and prevents cells overcharge by accordingly controlling the cut-off MOSFET switches. Also the voltage across the switches is monitored in order to prevent charge over-current. It stops charging when the cell voltage exceeds the specified maximum in order to prevent the battery from overheating or exploding due to overcharging.

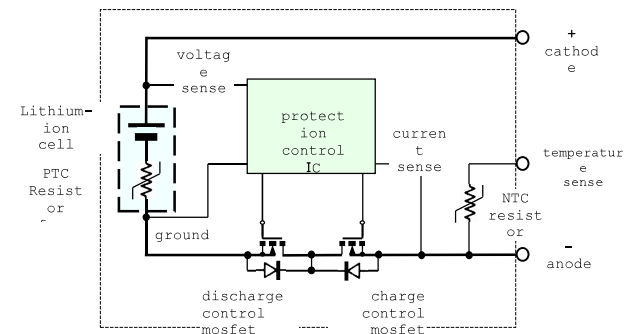

Figure 28.46. Protection circuitry for series connected double layer cells and Li-ion cells.

ii. **Over-discharge protection:** The control switches that are usually MOSFET structures, cut-off the discharge depending on the control signals from the controller. Also the switch voltages are monitored in order to prevent discharge over-current. Promptly stops discharging when a large current flows due to external shorting of the battery pack. Stops discharge when the voltage falls below the specified minimum in order to prevent battery degradation due to over-discharging.

iii. **Internal controller temperature protection:** The temperature fuse cuts off the current if the control MOSFET switches experience abnormal heating. This fuse is not resettable.

iv. **Over-temperature protection:** The negative temperature co-efficient thermistor (usually resettable NTC) measures the battery temperature inside the pack. Its terminals are connected to the charger so it can sense the temperature of the pack and control the charge current until the battery is full charged.

28.8 Battery thermodynamics

From chapter 27.14, a negative value for the Gibbs free energy indicates that a reaction is spontaneous in the forward direction. Conversely, a positive value indicates that a reaction is spontaneous in the reverse direction. Similarly, the standard electrochemical potential indicates whether the reaction goes forward ($E^\circ < 0$) or in the reverse direction ($E^\circ > 0$) under standard conditions. The connection between ΔG° and E° is given by the relationship (equation 21.14)

$$\Delta G^\circ = -nFE^\circ \quad (28.9)$$

where n is the number of moles of electrons transferred in the reaction and F is the Faraday constant, which corresponds to the electric charge on one mole of electrons: 96,487 C/mol.

Electrons are involved in an electrochemical reaction. Moving one Coulomb of charge, 1/96,487 moles of electrons, between two electrodes that differ by one volt requires one Joule of energy. Conversely, spontaneous movement of 1/96,487 moles of electrons between two electrodes with a potential difference of one volt releases one joule of energy to do useful work.

i. Equilibrium and the dead battery

Electrochemical reaction ceases when one of the reactant is depleted, usually because the anode is consumed such that electrons are no longer liberated. Another frequently encountered example is the magnesium stake used to protect a utility pole. When the stake is consumed, it no longer protects the pole from corrosion. Hence the magnesium stakes need to be regularly replaced.

Another reason for a dead battery is that the reaction reaches equilibrium, which means there is no net change and electrons no longer flow. Electron transfer occurs as part of the tendency toward equilibrium. At equilibrium, the forward and reverse reactions occur at the same rate. One consequence of the equal rates is that the number of electrons transferred from reactants to products is equal to the number transferred from products to reactants. The net flow of electrons, like the net flow of atoms, is therefore zero. With no net electron flow, the current is zero and so is the voltage. Often the voltage produced by a battery differs from the standard value, and the most common reason is that the solution-phase ions are not in their standard state: the ideal 1 M concentration.

The relationship between the standard voltage, E° , and the voltage, E , at temperature T , is determined by the relationship between the standard Gibbs free energy G° and the Gibbs free energy:

$$\Delta G = \Delta G^\circ + RT \ell n N$$

where R is the gas constant, 8.314 J/K mol, and N is the ratio of the effective concentrations of the products and reactants in the reaction.

Substituting equation (28.9), this equation becomes

$$-nFE = -nFE^\circ + RT \ell n N$$

or

$$E = E^\circ - \frac{RT}{nF} \ell n N \quad (28.10)$$

Equation (28.10) is referred to as the Nernst equation. At room temperature, the coefficient RT/F = 0.02569 V (= kT/q). Multiplication by 2.303 converts equation (27.18) into

$$E = E^\circ - \frac{0.0592V}{n} \ell n N$$

At equilibrium, E is zero and

$$E^\circ = \frac{RT}{nF} \ell n K$$

These electrochemical equations can be applied to the lead acid battery as follows.

The Nernst equation for the lead-acid cell can be written by adding the two half-cell reactions given in Table 28.4, where the overall reaction is:



The effect of sulphuric acid concentration on the electrode potential, is seen in equation (28.11). Using equation (28.10), the Nernst equation for the lead acid cell is

$$E = E^\circ - 2.303 \frac{RT}{nF} \times \log \frac{[a_{\text{H}_2\text{SO}_4}^2 \times a_{\text{H}_2\text{O}}^2]}{[a_{\text{PbO}_2} \times a_{\text{Pb}} \times a_{\text{H}_2\text{SO}_4}^2]}$$

where a is the activities of the reactants and the products of the cell, defined as an effective concentration. It is related to the actual concentration of the species, via, $a = \gamma C$. C , the molar concentration, is an activity coefficient. $a < C$, except in very dilute solutions where $\gamma < 1$ and $a > C$. $R = 8.314 \text{ J/K.mol}$, is the gas constant and T is the absolute temperature, in K.

Since the activity of a pure solid and water is 1, specifically $a_{\text{PbSO}_4} = 1$, $a_{\text{H}_2\text{O}} = 1$, $a_{\text{PbO}_2} = 1$, and $a_{\text{Pb}} = 1$.

$$\begin{aligned} E &= E^\circ - 2.303 \times \frac{RT}{nF} \times \log \frac{1}{a_{\text{H}_2\text{SO}_4}^2} \\ &= E^\circ + 2 \times 2.303 \times \frac{RT}{nF} \times \log a_{\text{H}_2\text{SO}_4} \end{aligned} \quad (28.12)$$

where $n = 2$ since n is the number of moles of electrons involved in the oxidation-reduction reactions in the equations in Table 28.4.

Equation (28.12) shows the effect of temperature and the activity (effective concentration) of H_2SO_4 , on the cell potential.

The activity of sulphuric acid is related to the actual electrolyte concentration as given by:

- $a_{\text{H}_2\text{SO}_4} = 4 \times m^2 \times C^2$ where C is the MOLAL concentration or molarity and m is defined as a mean activity coefficient.
- Typically, $a < C$, except in very dilute solutions ($< 0.001 \text{ M}$) when $\gamma_m \approx 1$ and $a < C$. The activity approaches unity for acid concentration in the range 3.5 to 4.0 M.

The activity coefficient is generally temperature and concentration dependent, and is experimentally determined.

Example 28.5: Electrochemistry – battery thermodynamics

Standard cell potentials can be used to determine the free energy change for a chemical reaction. Consider the copper–zinc galvanic cell:

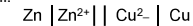

- Determine the potential of this cell and the free energy for the reaction.
- At room temperature, what is the relationship between the zinc and copper ion concentrations at equilibrium?
- If the cell produces 0.67 V, determine the ratio $[\text{Zn}^{2+}]/[\text{Cu}^{2+}]$.

Solution

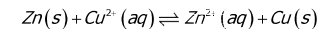

Since Cu and Zn are both solids, they do not appear in the equilibrium constant, N .

i. The half-reactions are

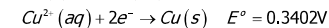
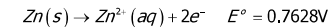

Cell potential $E = 0.7628 \text{ V} + 0.3402 \text{ V} = 1.103 \text{ V}$.

Since two electrons are transferred from copper to zinc, $n = 2$, $F = 96,485 \text{ C/mol}$, and $E^\circ = 1.103 \text{ V}$.

$$\Delta G^\circ = -nFE^\circ$$

$$\Delta G^\circ = -2 \text{ mol } e^- \times 96485 \text{ C/mol } e^- \times 1.103 \text{ V} \times 1 \text{ J/C.V}$$

$$= -212.8 \text{ kJ/mol}$$

Since the Gibbs free energy value is negative, the reaction is spontaneous for reactants and products in their standard states. For the solids, Zn and Cu, the solid is the standard state. For the ions in solution, Cu^{2+} and Zn^{2+} , the standard state is a 1 M solution. In contact with 1 M solutions, then, the reduction of copper by zinc is spontaneous.

ii. In equation

$$\Delta G^\circ = RT \ell n K$$

the equilibrium constant K is the ratio of the two ions, that is $K = [\text{Zn}^{2+}]/[\text{Cu}^{2+}]$. Thus

$$\begin{aligned} K &= e^{\frac{-\Delta G^\circ}{RT}} = e^{\frac{-(-212.8 \text{ kJ/mol})}{8.3145 \text{ J/K.mol} \times 298 \text{ K}}} \\ &= 1.99 \times 10^{37} \end{aligned}$$

The zinc ion concentration is about 37 orders of magnitude larger than the copper ion concentration at equilibrium. If the zinc ion is present in lower concentration, $N < K$, the reaction proceeds as written, generating a cell potential.

iii. Rearranging equation (28.10), $E^{\circ} = 1.103 \text{ V}$ and $E = 0.67 \text{ V}$ gives

$$N = e^{-\frac{(E-E^{\circ})nF}{RT}}$$

$$= e^{-\frac{-(0.67-1.103) \cdot 2 \cdot 96485 \text{ C/mol}}{8.314 \text{ J/mol}\cdot\text{K} \cdot 298 \text{ K}}} = 4.42 \times 10^{14}$$

As more Zn^{2+} ions are produced, the cell potential decreases even more, ultimately falling to zero. At that point, the Zn^{2+} ion concentration has increased to 1.99×10^{37} times the Cu^{2+} ion concentration.



Nuclear batteries function by converting the heat produced by a nuclear source, to create a current using the Seebeck-effect. A second type of nuclear cell uses beta-radiation impinging on a semiconductor junction to create an electron-hole pair that migrate to the electrodes of the junction creating a current, much in the same way that a solar cell creates energy from light. Currently these primary batteries are low power and are used to trickle charge existing batteries to give a longer lifetime or to power remote transducers.

28.9 Summary of key primary and secondary cell technologies

Table 28.21: Common commercial cell chemistries, batteries

cell name	nominal voltage	Capacity Wh/kg	anode	cathode	electrolyte
Primary cell					
carbon-zinc (Leclanche)	1.26	65	zinc foil	MnO_2	$\text{Aq Zn-C}_2\text{-NH}_4\text{Cl}$
zinc chloride (carbon-zinc)	1.5		zinc foil	Electrolytic MnO_2	Aq ZnCl_2
alkaline	1.5	95	zinc powder	Electrolytic MnO_2 powder	aq KOH
zinc-air	1.65	290	zinc powder	Carbon (air, O_2)	aq KOH
silver-zinc	1.6	130	zinc powder	Ag_2O	aq KOH
lithium-manganese dioxide	3.0	200		MnO_2	LiCF_3SO_3 or LiClO_4
lithium-carbon monofluoride	3.0		lithium foil	CF_x	LiCF_3SO_3 or LiClO_4
lithium-iron sulphide	1.6		lithium foil	FeS_2	LiCF_3SO_3 and/or LiClO_4
Secondary - rechargeable					
lead acid	2.0	35	lead	PbO_2	$\text{Aq H}_2\text{SO}_4$
nickel-cadmium	1.2	30	cadmium	NiOOH	aq KOH
nickel-metal hydride	1.2		MH	NiOOH	aq KOH
lithium ion	4.0		Lithium (C)	LiCoO_2	LiPF_6 non-aq solvent
nickel-hydrogen	1.2	55	H_2 (Pt)	NiOOH	aq KOH
lithium-iodine	2.7		lithium	I_2	LiI
lithium-silver-vanadium oxide	3.2		lithium	$\text{Ag}_2\text{V}_4\text{O}_{11}$	LiAsF
lithium-sulphur dioxide	2.8		lithium	SO_2 (C)	$\text{SO}_2\text{-LiBr}$
lithium-thionyl chloride	3.6		lithium	SOCl_2 (C)	$\text{SOCl}_2\text{-LiAlCl}_4$
lithium-iron sulphide	1.6		lithium	FeS_2	LiCl-LiBr-LiF
magnesium-silver chloride	1.6		magnesium	AgCl	Sea water

Table 28.22: Permissible temperature limits for various batteries

Older battery technologies are more tolerant to charging at extreme temperatures than newer, more advanced chemistries.

	Slow Charge ($\frac{1}{10}\text{C}$)	Fast Charge ($\frac{1}{2}\text{C to } 1\text{C}$)
Nickel Cadmium	0°C to 45°C	5°C to 45°C
Nickel-Metal Hydride	0°C to 45°C	10°C to 45°C
Lead Acid	0°C to 45°C	5°C to 45°C
Lithium Ion	0°C to 45°C	5°C to 45°C

Table 28.23: Charging of different chemistries

	Lead-acid (sealed or flooded)	Nickel-based (NiCd and NiMH)	Lithium-ion (Li-ion)
Deplete all battery energy before charging?	Better to recharge more often; avoid frequent full discharges. Deep cycles deteriorate the battery. Use a larger battery if full cycles are required.	Fully discharge once every 1-3 months to prevent memory. Not necessary to deplete the battery before each charge. Over cycling wears down NiMH.	Better to recharge more often; avoid frequent full discharges. For batteries with a fuel gauge, fully discharge once a month to enable reset.
Partially or fully charge battery?	Does not matter. Charging in stages is acceptable. Full charge termination occurs by reading the voltage level and charge current. Charging a full battery is safe and does not cause harm.	Allow full charge without interruptions. Repeated partial charge can cause heat buildup. (Many chargers terminate charge by heat. A fully charged battery will re-heat, causing overcharge.)	Does not matter. Charging in stages is acceptable. Full charge termination occurs by reading the voltage level and charge current. Charging a full battery is safe and does not cause harm.
Battery charged state when not in use?	Always keep battery fully charged. A discharged battery causes sulphation (insulating layer in the cell). This condition is often irreversible.	Not critical. A 40% charge for long storage. (Open terminal voltage cannot determine state-of-charge.) Store in a cool place. Battery can be fully depleted and recharged. Priming may be needed.	Best to store at 40% charge or 3.75-3.80V/cell open terminal. Cool storage is more important than state-of-charge. Do not fully deplete battery because Li-ion may turn off its protection circuit.
Battery heat up during charge?	The battery should remain cool or lukewarm. The battery must remain cold on maintenance charge.	Heating towards full charge. The battery must cool down before use. Discontinue using a charger that keeps the battery warm on standby.	Little heating is generated during charge. Do not allow the battery to heat during charge.
Allowable charging temperatures?	Rechargeable batteries can be used over a wide temperature range, but charging is usually not permitted at the extremes. The maximum allowable charge temperatures are shown below:		
Slow charge (0.1) Fast charge ($\frac{1}{2}\text{-}1\text{C}$)	0°C - 45°C 5°C - 45°C Warm temperature lowers the battery voltage. Serious overcharge occurs if the cut-off voltage is not reached.	0°C - 45°C 5°C - 45°C Charging a hot battery decreases the charge time. The battery may not fully charge.	0°C - 45°C, 5°C - 45°C Temperature sensor may prevent charge or cut off the charge prematurely.
Charger requirements?	Multi-level charges shorten charge time. Charge must be fully saturated. Failing to do so will gradually decrease the capacity. Fastest full-charge time: 8 to 14 hours.	Best results are achieved with a fast-charger that terminates the charge by other than temperature alone. Fastest full-charge time: slightly over 1 hour.	Charger should apply full charge. Fastest full-charge time: 2 to 3 hours.

28.10 The Electrochemical Double Layer Capacitor (EDLC) - supercapacitor or ultracapacitor

Unlike batteries, which store energy chemically, capacitors store energy as an electrostatic field. Typically, a battery stores energy and little power; a capacitor provides large instantaneous power, but relatively low energy. A capacitor is made of two conducting plates and a separating electrical insulator called the dielectric, which conducts ionically, but not electrically. In a capacitor

$$W = qE = \frac{1}{2}CE^2 \quad (J) \quad (28.13)$$

where the capacitance, C , is directly proportional to the overlapping surface area A of the plates and inversely proportional to the distance between them, d .

$$C = \epsilon_0 \epsilon_r \frac{A}{d} \left(= \frac{Q}{E} \right) \quad (F) \quad (28.14)$$

As the plate surface area increases and the separation between the plates decreases, the capacitance increases and storable energy increases. Aluminium electrolytic capacitors attain capacitance volumetric densities of about 50F/m³. But for useful energy storage as in a battery, several orders more capacitance per cubic metre is needed, as seen in figure 28.2. The double layer capacitor stores energy electrostatically by polarising the electrolytic solution and attains these necessary capacitance density levels by increasing the surface area to about 2,000m²/g, in a small volume. This is equivalent to 100F/g of electrode active mass.

The supercapacitor increases the electrode area just like a polymer foam cleaning sponge with millions of crenulations. But in the supercapacitor this is achieved with carbon – activated charcoal particles (or sintered metal powders), which form a non-reactive, conductive, random, rough, porous, carbon fibre surface with an extraordinarily large surface area in a small volume, with a small charge separation distance, of less than 10 Angstroms.

The second non-reactive porous electrode is activated when the molecule size voids are impregnated with a conductive liquid (for example, an aqueous acid or salt solution). Thus the supercapacitor can be viewed as two non-reactive porous plates suspended within an electrolyte.

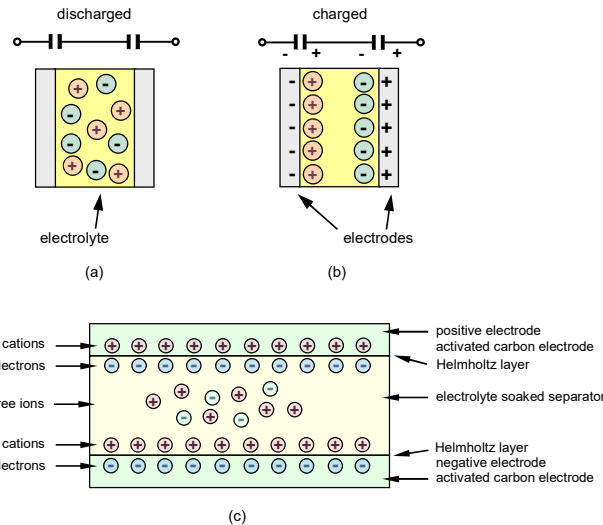

Figure 28.47. Supercapacitor (EDLC) showing formation of the double charge boundary layers: (a) discharged state; (b) fully charged state; and (c) partially discharged.

The dielectric is based on an electrical double layer, each layer conductive, but the interface is non-conductive. The electrodes have a physical barrier made from activated carbon that, when an electrical charge is applied to the material, a double electric field is created which acts like a dielectric, as shown in figure 28.47. This ultra-thin non-electrically conducting insulator layer on the carbon produces high capacitance.

Although the supercapacitor is an electrochemical device, no chemical reactions are involved in the energy storage mechanism. Rather the electrolytic solution is polarised by the electrode potentials, forming an ion absorption layer on the activated carbon electrodes, in order to store energy electrostatically by microscopic charge separation at the electrochemical interface. The double layer interface potential distributions are shown in figure 28.48. The mechanism is readily reversible, as is the charge polarity since the anode and cathode are generally composed of the same material.

Due to the thin (of the order of nanometres) dielectric layer thickness, supercapacitors have low voltage ratings of typically 2V to 5V, which restricts energy storage magnitudes, since the stored energy is proportional to the square of the voltage, yet the breakdown electric field is proportional to dielectric thickness. Since conduction through an ionic liquid is relatively slow, discharged limits are lower than with standard capacitors, but can be discharged (and charged) quickly compared to electro-chemical batteries. Applying a voltage differential between the positive and negative plates charges the supercapacitor. If the electrode voltage difference is increased to the decomposition voltage, current begins to flow due to electrolyte break down.

Whereas a dry capacitor consists of conductive foils and a dry plastic separator, like the electrolytic capacitor, the supercapacitor crosses into battery technology by using special electrodes and an electrolyte.

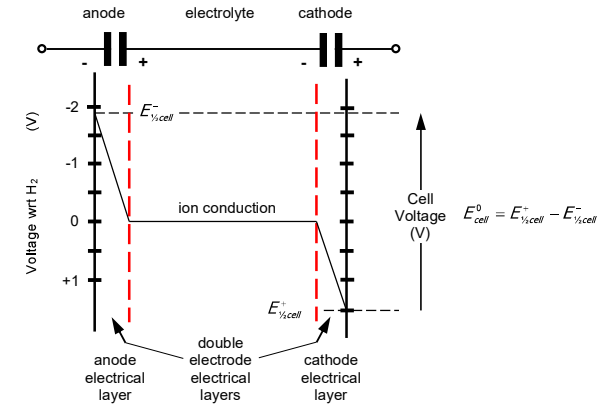

Figure 28.48. Voltage potential profile across the battery cell, fuel cell or electrochemical capacitor, where the structure and composition of the electrical double layers differ at the anode and cathode.

i. Electrodes

As with Li-ion technology, higher useable surface areas are attained with regular lattice structures. In the case of the supercapacitor, this is offered by carbon nanotubes, activated polypyrrole, and nanotube impregnated papers. Higher voltage properties are offered by improved insulators based on the piezoelectric material barium titanate coated with aluminium oxide and glass.

- Carbon
 - Activated – graphite Basal plane, hexagonal structure
 - graphite
 - black
 - nanotube
 - Carbon nanotubes have excellent nanoporosity properties, allowing tiny spaces for the polymer to sit in the tube and act as a dielectric.
 - carbon aerogel
 - Supercapacitors are also made of carbon aerogel. The electrodes of aerogel supercapacitors are usually of non-woven paper made from carbon fibres and coated with organic aerogel, which then undergoes pyrolysis. The paper is a composite material where the carbon fibres provide structural integrity and the aerogel provides the required large surface.
 - carbon fibre

- metal oxide, see 28.10.8.
 - RuO₂
 - TiNO_x
 - FeN_x
- Some conducting polymers, for example, polyacenes, have a redox (reduction-oxidation) storage mechanism along with a high surface area, see 28.10.8.

In the case of carbon aerogels, the desirable properties are:

- Solid substances similar to gels but where the internal liquid is replaced with air.
- Porous and lightweight. They are typically 50 to 99.5% air, yet can theoretically hold 500 to 4,000 times their weight in applied force. They can have surface areas ranging from 250 to 3,000 m²/g, equating to 250F/g.
- One of the best insulators and lowest density solids.
- This technology will improve ultracapacitors by swapping in carbon nanotubes. This greatly increases the surface area of the electrodes and the ability to store energy since the amount of energy super-capacitors can retain is related to the surface area and electrode conductivity.
- They can be produced as thin films, powders, monoliths, or micro-spheres. The main problem is the cost.

The high surface area electrode activated carbon material is the cheapest of the possibilities to manufacture and is the most common. Since it stores the energy in the double layer formed at the carbon electrode surface, such a structure is termed a Double Layer Capacitor.

ii. Electrolyte

The electrolyte may be aqueous (H₂SO₄ or KOH) or organic, or a mixture of volatile acetonitrile and ionic salts. The aqueous electrolytes offer low internal resistance but limit the voltage to 1.23V. An organic electrolyte allows a dissociation voltage of greater than 2.5V (about 4 times the energy density), but the internal resistance is higher. Due to the high conductivity of the electrolyte, in spite of the small distance between the electrodes, a series equivalent resistance in the mΩ range is achieved (resulting in an RC time constant of about 1s) with the entire electrolyte being absorbed in the activated carbon layer. However, with both electrolyte types, the internal resistance is less than that of an electrochemical battery.

iii. Separator

The separator, about 25μm thick, (organic electrolytes use polymer or paper while aqueous electrolytes use glass fibre or ceramic), has three functions to fulfil in supercapacitor technology:

- provide electrical insulation between the electrodes of opposite polarization,
- support the ionic conduction from one electrode to the other, and
- must not be electrically conducting.

The separator series resistance is proportional to the separator thickness which is in the range of 10 to 100 micrometre and inversely proportional to its area. The conductivity through the separator is proportional to its porosity (40% to 70%) and is given by

$$\sigma = \sigma_o \times \rho^\alpha \quad 1.5 < \alpha < 2 \quad (28.15)$$

where σ_o is the electrolyte conductance, ρ is the porosity, and α is a power factor.

Most separators are a cellulose based material or porous polypropylene. They are produced in the form of self-standing films. Some other special materials (ceramic, PTFE, etc.) are intended to overcome the temperature limitation of traditional separators. The film thickness should be as thin as possible. Its minimum thickness is limited by the electrical shorting failure risk due to free carbon particles which may create a contact between the two electrodes, and reduced mechanical tension may lead to tearing of the film during the winding process.

28.10.1 Double layer capacitor model

C_{DLa} and C_{DLc} are the double layer capacitances of the anode and cathode respectively, R_i is the internal electrolyte resistance, and Z_{DL} represent the electrode impedance and dielectric leakages of the cell, as shown in figure 28.49.

For capacitors in series

$$\frac{1}{C_{DL}} = \frac{1}{C_{DLa}} + \frac{1}{C_{DLc}} \quad (28.16)$$

where for a supercapacitor $C_{DLa} = C_{DLc}$ thus

$$C_{DL} = \frac{1}{2} C_{DLc} \quad (28.17)$$

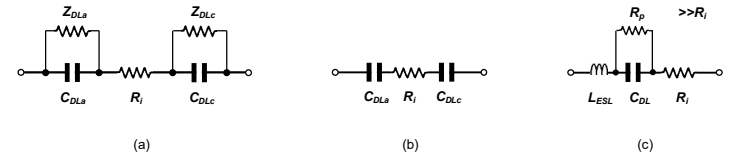

Figure 28.49, Derivation of the electrical equivalent circuit of the double-layer super-capacitor: (a) electrode-solution interface capacitance and impedances; (b) double-layer capacitances and electrolyte resistance; and (c) R-C series equivalent circuit model, with equivalent series inductance.

Ultracapacitors exhibit non-ideal behaviour, which results primarily from the porous material used to form the electrodes that causes the resistance and capacitance to be distributed such that the electrical response mimics transmission line behaviour. Therefore, in some modelling situations, it may be more useful to model the ultracapacitor as a distributed RC transmission line.

As shown in figure 28.50, an ultracapacitor's voltage profile, under a constant current discharge, has the capacitive component $\Delta V_C = I\Delta t/C$ and resistive component $\Delta V_{ESR} = IR$, represented by

$$\Delta V = \Delta V_{ESR} + \Delta V_C = I \times \left(R + \frac{\Delta t}{C} \right) \quad (28.18)$$

where, $\Delta V = V_w - V_{min}$ is allowable change in voltage [V], I is current [A], R is ESR [Ω], Δt is charge or discharge $t_{discharge}$ time [s], and C is capacitance [F].

The charge profile is similar, but voltages increase rather than decrease.

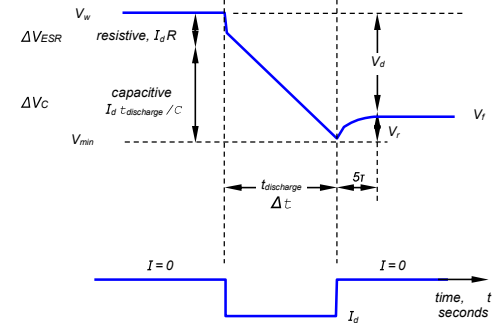

Figure 28.50. Voltage-time discharge profile of a supercapacitor.

Minimum allowable operating voltage, power/current requirements, and discharge time all determine cell size, and number of cells in parallel (and series). The number of cells in series, N_s tends to be specified by the voltage requirement, while the current requirements are specified by the number of cells in parallel, N_p . Since identical cell types must be used (to ensure proper sharing), the equivalent capacitance and series resistance are given by

$$C_s = C_{cell} \times \frac{N_p}{N_s} \quad R_s = R_{cell} \times \frac{N_s}{N_p} \quad (28.19)$$

The RC time constant remains constant ($R_s C_s = R_{cell} C_{cell}$).

The basic information needed to determine the required ultracapacitor size (F), for a given application is:

- maximum operating voltage, V_w
- minimum allowable operating voltage, V_{min}
- power or current
- discharge duration (power required in each pulse) and allowable voltage change
- repetition rate
- temperature and required life

Example 28.6: Ultracapacitor module design using a given cell

A 10kW un-interruptible power supply, UPS, application requires energy back up for 5 seconds. The operating voltage is 56V, and must operate down to half that voltage. The nominal tolerance on the input is better than 7.5%.

The specifications for the supercapacitor cells are as follows (at $T_{cell} = 25^\circ\text{C}$):

$$\begin{aligned} R_{max} &= 0.47 \text{ m}\Omega \\ C_{max} &= 1500 \text{ F} \\ V_w &= 2.5 \text{ V} \end{aligned}$$

Will a module based of these cells fulfil the necessary back up function?

Solution

The average current requirement over 5 seconds, in order to maintain 10kW as the module voltage drops, is

$$\begin{aligned} \bar{I} &= \frac{\text{power}}{V} = \frac{\text{power}}{\frac{1}{2}(V_{max} + V_{min})} \\ &= \frac{10,000}{\frac{1}{2}(56+28)} = 238\text{A} \end{aligned}$$

The number of series cells N_s for maximum voltage (107.5%) is

$$N_s = \frac{V_{max}}{V_w} = \frac{60\text{V}}{2.5\text{V}} = 24 \text{ cells in series}$$

Assuming no parallel connection is necessary, $N_p = 1$, the module capacitance and resistance are

$$C_s = C_{cell} \times \frac{N_p}{N_s} = 1500\text{F} \times \frac{1}{24} = 62.5\text{F}$$

$$R_s = R_{cell} \times \frac{N_s}{N_p} = 0.47\text{m}\Omega \times \frac{24}{1} = 11.3\text{m}\Omega$$

Equation (28.18) is used to estimate the voltage drop during the 5-second period, that is

$$\begin{aligned} \Delta V &= I \times (R + \frac{\Delta t}{C}) \\ &= 238\text{A} \times (11.3\text{m}\Omega + \frac{5\text{s}}{62.5\text{F}}) = 2.7\text{V} + 19\text{V} = 21.7\text{V} \end{aligned}$$

Since the specification allowed a voltage decrease of 28V, (56V - $\frac{1}{2}$ 56V), the expected 21.7V is within the specification limit. The necessary capacitance per cell can be decreased to $1500\text{F} \times 21.7/28\text{V} = 1162\text{F}$.

28.10.2 Cell parameter specification and measurement methods**i. Charging and discharging specification**

The time required for constant current and constant resistance discharge are represented by equations (28.20) and (28.21) respectively. It is assumed the internal resistance is negligible.

Charge/discharging time of constant current charge/discharge

$$t = C \times \frac{|\Delta V_0|}{i} = C \times \frac{|V_0 - V_f|}{i} \quad (28.20)$$

Charge/discharging time of constant resistance R charge/discharge

$$t = CR \times \ln \frac{V_{source} - V_0}{V_{source} - V_f} \quad (28.21)$$

where t = charge/discharging time (s), V_{source} = external voltage source (V), V_0 = initial voltage (V), V_f = final voltage (V), and i = capacitor current (A).

The ultracapacitor terminal voltage is measured during charge/discharge, that is, under load.

ii. Capacitance specification

Initially the capacitor is slowly charged over a 30-minute period to rated voltage. The capacitor is then discharged at a constant rate of 1mA/F, producing a linear decrease in terminal voltage. The time is measured for the terminal voltage to drop from 70% to 30% of rated voltage and the capacitance is given by

$$C = i \times \frac{t_{0.7V_R} - t_{0.3V_R}}{V_{0.7V_R} - V_{0.3V_R}} = i \times \frac{t_{0.7V_R} - t_{0.3V_R}}{0.7 \times V_R - 0.3 \times V_R} \quad (\text{F}) \quad (28.22)$$

where the voltages and times correspond to 70% and 30% of the capacitor rated voltage, V_R .

Alternatively the calculation is performed for the period when the rated voltage decreases to 50% of rated voltage.

iii. Equivalent Series Resistance, AC and DC ESR, specification

AC ESR is measured with a 4-probe impedance analyzer at an AC amplitude of 5mV and a frequency of 100Hz or 1kHz. Because of the ultracapacitor time constant, typically one-second, operation at these frequencies is inefficient. The ac resistance is used to define the volumetric and gravimetric power densities as follows.

$$\begin{aligned} P_v &= \frac{V_{Rated}^2}{4R_{ac}} \times \frac{1}{\text{Volume } dm^3} \\ P_g &= \frac{V_{Rated}^2}{4R_{ac}} \times \frac{1}{\text{Weight } kg} \end{aligned} \quad (28.23)$$

The DC ESR is measured after the capacitor has been slowly charge to rated voltage. The ultracapacitor is then discharged at a constant current of 1mA/F. The internal resistance voltage drop of ΔV is measured (the final voltage is taken 5 seconds after the constant current loading is removed) and the internal resistance, expressed in m Ω , is calculated from

$$R = \frac{\Delta V}{i} \quad (\text{m}\Omega) \quad (28.24)$$

The total internal dc resistance is comprised of resistive components attributed to contact, electrode, electrolyte, and other material resistances.

iv. Leakage current specification

The capacitor is charged with the rated voltage at 25°C for at least 12hrs, typical 72 hours. Then the voltage source charging current, whence leakage current, is measured.

28.10.3 Cell characteristics**i. Charge/discharge**

Typically, the supercapacitor has an RC time constant of about one second, whence the efficient charge time of a supercapacitor is better than 10 seconds. Both charge and discharge rates tend to be limited by the current related internal heating of the electrodes, while peak current is limited by the internal resistance. The internal resistance (measured at a low frequency, $\frac{1}{3}$ Hertz), increases significantly below 0°C , doubling at -40°C , as seen in figure 28.51. The charge characteristics are similar to those of an electrochemical lead-acid battery. Full charge occurs when a set voltage limit is reached. When the charge open circuit voltage is reached, charging stops, without danger of overcharge or *memory* effect. The initial charge is rapid, with current limiting required; the topping charge takes extra time. Over charging (higher voltages), reduces lifetime, whilst uncontrolled charging can damage cell shunt protection circuitry.

The supercapacitor can be rapidly charged and discharged virtually an unlimited number of times. Unlike the electrochemical battery, there is little deterioration or detrimental stress induced by cycling and age does not significantly affect the supercapacitor. In normal use, a supercapacitor deteriorates to about 80% charge capability after 10 years. Lifetime is usually defined as a 20% reduction in capacitance and/or a 200% increase in resistance (see estimated life duration).

Because of the typical one-second internal RC time constant, short circuiting need not be fatal and provided thermal limits are observed, consequential open circuit failure can be avoided.

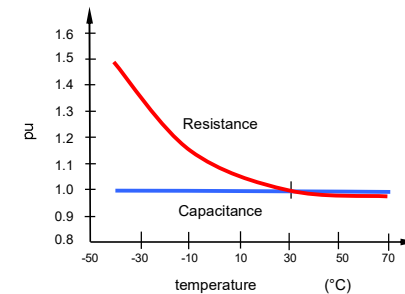

Figure 28.51. Supercapacitor temperature dependence of capacitance and internal resistance.

The internal self-discharge of the supercapacitor (<1µA) is substantially higher than that of an electrochemical battery. Organic electrolyte supercapacitors discharge most. In 30 to 40 days, the capacity decreases from full charge to 50%, with 1.2% per day charge decrease being typical. In comparison, a nickel-based battery discharges about 10 percent during the same month period. Figure 28.51 show the per unit increase in internal resistance at lower temperatures, whilst in comparison, capacitance is virtually temperature stable.

ii. Frequency response

Ultracapacitors have a typical time constant of approximately one second, for both step voltage source charging and discharging. Therefore, it is not possible to expose ultracapacitors to a continuous ripple current as internal overheating may result. The ultracapacitor can respond to short pulse power demands, but due to the time constant the efficiency or available energy is reduced. Figure 28.52 illustrates the performance of the ultracapacitor at various frequencies. The drop off in capacitance is associated with the response time necessary for the charged ions within the pores of the electrodes to transport between positive and negative electrodes during charge and discharge. The drop in resistance is representative of the response time of the different resistive elements within the ultracapacitor. At low frequency, all resistive elements are present while at high frequency, only quick response elements such as contact resistance are present.

The continuous DC current density recommended for maximum long life reliable operation of the ultracapacitor cells is 50mA/F. The cells operate effectively at higher current densities however, potential cell damage can occur depending on the magnitude and duration/duty cycle of the high current pulses.

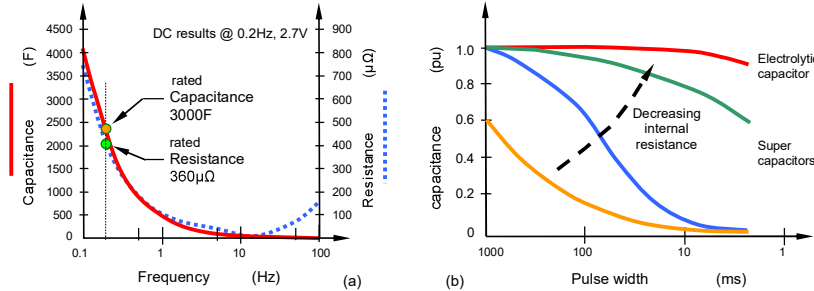

Figure 28.52. Supercapacitor frequency dependence of capacitance and internal resistance.

Two factors are critical in determining the voltage drop when a capacitor delivers a short current pulse; namely the ESR and 'available' capacitance as shown in figure 28.52b.

The instant voltage drop ΔV_{ESR} is caused by and is directly proportional to the capacitor's ESR. The continuing voltage drop with time ΔV_C , is a function of the available charge, that is, capacitance. From figure 28.50, it is apparent that, for short current pulses, for example, in the millisecond region, the combination of voltage drops in a conventional supercapacitor caused by, first the high ESR and second, the lack of available capacitance, causes a total voltage drop, unacceptable for many applications. Low ESR, (< 1mΩ), minimizes the instantaneous voltage drop, while the high internal capacitance drastically reduces the severity of the charge related drop.

Ultracapacitors used in electric drive-trains to load-level the battery, experience steady dc, much like the battery, rather than small amplitude ac signals. The dc charge or discharge time t_{disch} of the capacitor is related to the fundamental characteristic frequency (f_{ac} in Hz) of the ac voltage on the capacitor by $t_{disch} \gg 1/f_{ac}$. Hence, for backup applications, the ac signals are less than 10Hz.

In testing ultracapacitors, they are conveniently modelled as a simple series RC circuit when inductive effects are not important. Then $Q = CV$, $W = \frac{1}{2}CV^2$ and $V_o - V = iR + (Q_o - Q)/C$, where Q is charge on the capacitor, V is voltage on capacitor, W is energy stored in the capacitor, and V_o and Q_o are voltage and charge at $t = 0$, respectively. Based on these assumptions, figure 28.53 parts a and b show capacitor voltage variation during constant current and constant power discharge.

28.10.4 Thermal properties

Many ultracapacitors applications utilize the components under high duty cycles. One of the factors attributing to ultracapacitor performance reduction is temperature. For minimum performance influence over the equipment life, it is necessary to maintain the ultracapacitor core temperature within its rated temperature range. The lower the maintained core temperature, the longer the life.

If cells are provided with an electrically insulating shrink sleeving around the capacitor body and since all current passes through the capacitor terminals, cooling at the capacitor ends or terminals is the most efficient means of capacitor cooling.

Depending on the duty cycle of the application, cooling can be accomplished via heat sinks (conduction), air-flow (convection) or a combination of the two. Consideration of duty cycle and resulting capacitor temperature as well as the anticipated ambient temperature surrounding the capacitor, is necessary. The combination of both should not exceed the operating temperature for the ultracapacitor.

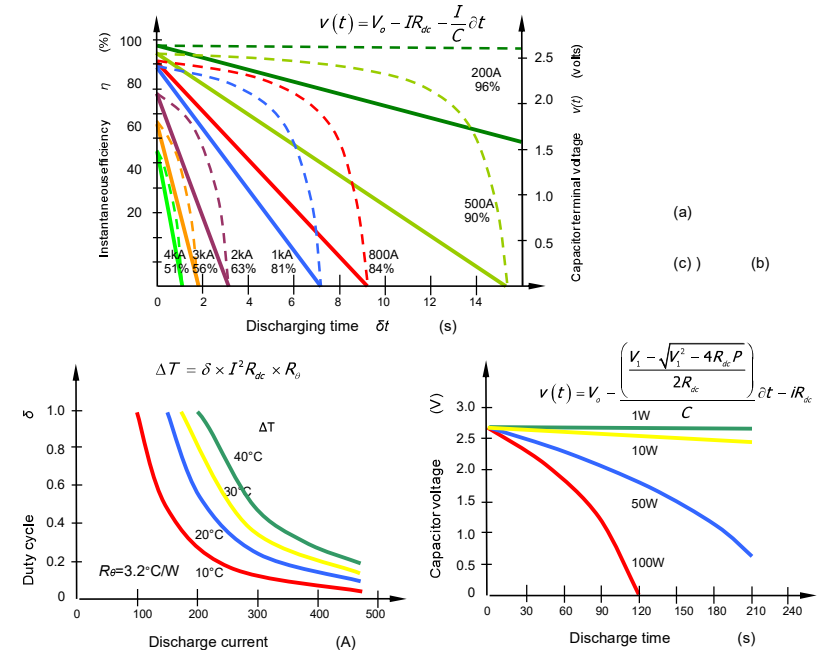

Figure 28.53. Supercapacitor 3000F, 2.7V, 0.29mΩ cell performance characteristic profiles: (a) constant current discharge, (b) constant power discharge, and (c) thermal dissipation with free convection in a 25°C ambient.

The thermal resistance, or R_θ (°C/W), is based on free convective cooling, and is improved by active cooling. Utilizing R_θ , the temperature rise can be predicted based on the application current and duty cycle. Typical core temperature rise (above ambient) dependence on current and duty cycle are shown in figure 28.53c. This temperature rise is then added to the ambient temperature to determine the maximum current and duty cycle to maintain the capacitor within its operational specification and the application life requirements. The core temperature rise of the capacitor is predicted by:

$$\Delta T = \delta \times I^2 R_{dc} \times R_\theta$$

where δ = duty cycle (0 to 1), I = current, R_{dc} = dc resistance or low frequency based on constant discharge (non-pulsing).

Alternatively, for ac currents the high frequency resistance should be utilized with pulsing currents.

28.10.5 Estimated life duration

During use, capacitance decreases and internal resistance rises, as shown in figure 28.54. The lifetime of an ultracapacitor is affected by ambient temperature, applied voltage, and operating current. Capacitor lifetime is increased by reducing these factors.

i. Operating Temperature Dependence

Capacitor life is affected by operating temperature. In general, lowering ambient temperature by 10°C doubles the life of a capacitor. Operation above the maximum specified temperature not only shortens capacitor life, but can also cause damage such as electrolyte leakage. The operating temperature of the capacitor not only involves the ambient temperature and internal self-heating generated temperature, due to dc and ripple current, but also radiation from other nearby heat generating elements.

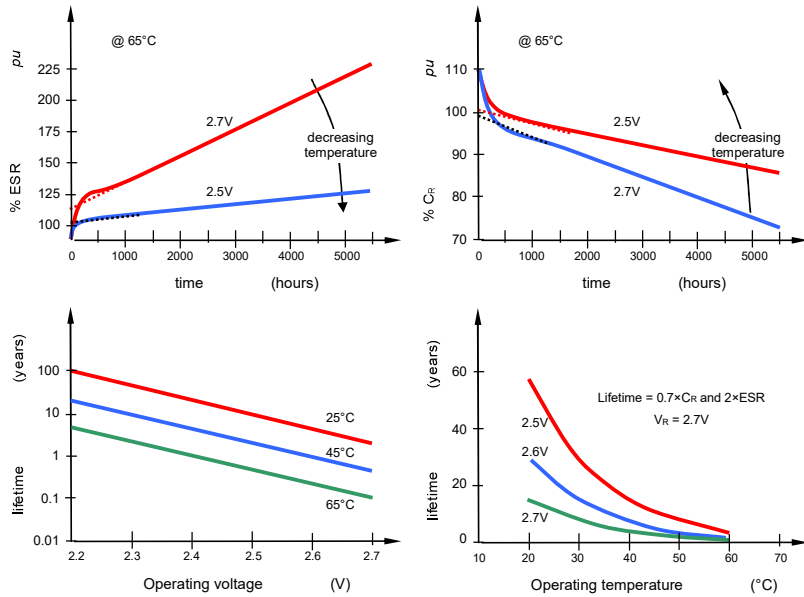

Figure 28.54. Supercapacitor parameter variation (lifetime) over time (cycling) and with temperature and voltage (a) equivalent internal series resistance, (b) rated capacitance, (c) operating voltage, and (d) operating temperature.

ii. Voltage Dependence

If an ultracapacitor is used at a voltage exceeding its rated voltage, not only is its lifetime shortened, but depending on the actual voltage, gas generated by electrochemical reactions inside the capacitor may cause leakage or rupture. Reverse voltage polarity is allowed but may shorten the life expectancy.

Figure 28.54c show the deterioration of lifetime related parameters, over time, depending on operating voltage and operating temperature.

High-temperature load lifetime is used to measure the lifetime of an ultracapacitor. For example, 1000 hours under full charging conditions at a temperature of 70°C is equivalent to 7.3 years at room temperature, 25°C, under normal use.

The lifetime criteria are:

- A reduction in capacitance of 30%, $C_{limit} = 80\%C_{nominal}$, and
- An increase in ESR (equivalent serial resistance) of 100%.

These electrical parameter operational limits are referred to as endurance capacitance and endurance resistance. Typically capacitance decays to the -20% level before the ESR doubles. Therefore, capacitance is generally the first parameter to experience end of life based on the arbitrary criteria.

The progression of capacitance in time is separated into three distinct sequential periods, as shown in figure 28.55:

- Exponential decrease during the first hours/cycles (burn-in)
- Linear decrease during the main part of the life
- Slow exponential decrease due to supercapacitor natural ageing (burn-out)

The lifetime model applies only when the capacitor is operating in the middle period in which there is a linear decrease of capacitance (and a linear increase in ESR) over time.

From figure 28.55, estimated life duration, ELD, for a 30% decrease in capacitance, is defined by:

$$\frac{C_1 - C_2}{\Delta t} = \frac{C_1 - C_{limit}}{EDL} \quad \text{that is} \quad EDL = \Delta t \frac{C_1 - C_{limit}}{C_1 - C_2}$$

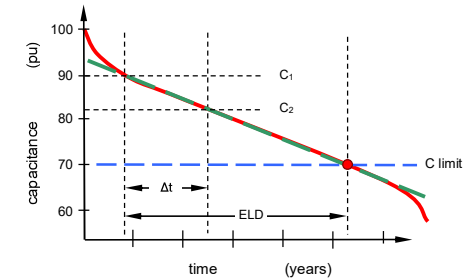

Figure 28.55. Supercapacitor lifetime determination.

A phenomenon termed *recovery* is observed, which is to be avoided during lifetime measurement periods. If the capacitor loading is interrupted after a long period of continuous usage (DC or voltage cycles), the measurement of capacitance and series resistance show a recovery as a function of the time without use. The capacitance recovery is explicit in the voltage recovery V_r , shown in figure 28.50, after the load is removed.

28.10.6 Cell voltage equalization in a series stack of ultracapacitors

Many applications require that capacitors be series and/or parallel connected, to form a 'bank' or 'module' with a specific voltage and capacitance rating. Because sustained overvoltage can cause an ultracapacitor to fail, the voltage across each cell in a series stack must not exceed the maximum continuous working voltage rating of individual cells in the stack. The charging electronics must either reduce the rate of charge being delivered to a cell, or stop charging a cell whose voltage approaches its surge voltage rating.

i. Cell balancing in low duty cycle applications

The voltage distribution in a series stack of ultracapacitors initially and during transients is a function of capacitance. After the stack has been held at voltage for a period-of-time, the cell voltage distribution becomes a function of leakage current, modelled by current through internal parallel resistance.

Initially, the cells with greater capacitance will be charged to lower voltages while the cells with smaller capacitance will be charged to higher voltages. This is because each series cell conducts the same current, and voltage is a function of current and capacitance. The average cell voltage will be the total voltage divided by the number of capacitor cells.

Any cell supporting voltage discharges through internal parallel resistance. The current through this parallel resistance is referred to as leakage current. The leakage current has the effect of self-discharging the cell.

After a period-of-time, the voltages on the individual cells will vary based on the differences in leakage current, rather than on the differences in capacitance. The cells with higher leakage retain lower cell voltages, and vice versa. This is because the higher leakage current discharges the cell, lowering its voltage. If the series string is supplied from a constant voltage source, this voltage, via the leakage current, is redistributed onto other cells in the series arrangement.

One technique to compensate for variations in leakage current is to place a bypass resistor in parallel with each cell, sized to dominate the total cell leakage current. This effectively reduces the variation of equivalent parallel resistance between the cells. For instance, if the cells have an average leakage current of 10uA ±3uA, a resistor with 1% tolerance which bypasses 100uA ± 1uA is appropriate. The average leakage current becomes 110uA, ±4uA. Introduction of this resistor decreases the variation in leakage current from 30% to 3.6%.

Since the parallel resistances are the same, the cells with higher voltages will discharge through the parallel resistance at a higher rate than the cells with lower voltages. This distributes the total stack voltage uniformly across the entire series of capacitors. See series voltage sharing in Chapter 11.

A typical trade-off is based on time to balance versus leakage current; the faster the balancing circuit responds, the greater the leakage. A 100:1 ratio of bypass resistor leakage current to cell leakage current may take days to balance a severely unbalanced bank, while a 10:1 ratio may balance in a few hours. Once the system is balanced, response time is less of an issue unless the bank is severely cycled.

For high duty cycle applications, more efficient, active balancing is normally used, as follows.

ii. Active voltage management methodology

The active balancing circuit has an active switching device, like a bipolar transistor or MOSFET, connected in series with each bypass element ladder. The switches are controlled by voltage-detection circuits that only turn a switch 'on' when the voltage across that particular cell approaches a value slightly below the continuous working-voltage rating of the cell. This is called the bypass threshold voltage. Figure 28.56 depicts a typical circuit diagram of an active charging-current diversion circuit.

Key balancing circuit features:

- elimination of module-to-module balancing requirements
- improved efficiency with reduction of parasitic losses
- improved operation over full range of temperatures
- improved filtering and operation with noisy input power
- increased balancing power for quicker balancing

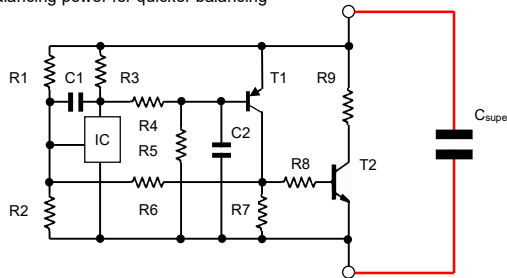

Figure 28.56. Supercapacitor voltage balancing circuit.

Balancing electronics is a current sinking topology capable of sinking current at 300mA to 400mA from each individual cell, whenever the specific cell voltage is at least 2.73V. The on-off trigger of the voltage management circuits are optimized for performance in terms of temperature and other influences. Each cell voltage is individually monitored against a nominal reference voltage. When the cell voltage reference is exceeded, the voltage management circuit discharges the cell voltage to below the trip level. Then the voltage management circuit for that cell enters a quiescent state with respect to balancing activity. Maintaining the cell voltage below this 'trigger' level assures cell long lifetime and, therefore, module long lifetime.

The circuitry features tolerance to a full charge reversal, without damage to the circuit electronics or capacitors. If an ultracapacitor module is allowed to approach complete self-discharge, it is possible that some capacitors in the module experience a negative voltage. This negative state and subsequent recharging of the module will not damage the balancing electronics.

Circuit temperature compensation enables identical performance from the circuit over the range of allowable operating temperatures. This is accomplished through a stable voltage reference subsystem for the entire temperature range ensuring accuracy of the balancing scheme while in operation. This also prevents voltage management circuit instability during cell fast transient voltage conditions (discharge-charge) or if the voltage management circuit is supplied with the current from the capacitor.

Integrated monitoring indicates an extreme stop-charge condition (when the cell exceeds maximum allowed operating voltage). The circuit 'triggers' at 2.73V and rapidly reduces the cell voltage to below the threshold of 2.70V, at which point a quiescent state reoccurs. Typical balance times are measured in minutes and the smaller the cell capacitance the more rapidly the voltage management circuit reduces the cell voltage.

The circuit quiescent current is approximately 30uA at room temperature. As a result, modules (including the heavy-duty transportation modules) featuring this circuit experiences an extremely low parasitic discharge. In addition, the design tolerates a wide variation in input power making it robust relative to any 'dirty power' requirement.

High-voltage modules have a single opto-isolated output for over voltage indication when any cell in the string approaches an over voltage condition, 2.80V, \pm 0.6V. This signal monitors that the state of charge of each cell in the module is in the safe operating range. Active voltage balancing occurs prior to the

threshold for output of the over voltage signal, hence can be used as a stop charge signal. Charging can resume when the signal is no longer present. When the over voltage signal is triggered, failure to stop the charging will result in charging the cell to even higher voltages, damaging the cell or shortening the cell lifetime depending upon the charge rate. Monitoring the over voltage signal when operating the bank near its maximum voltage can be used to maximize bank lifetime. An ultracapacitor can operate at its maximum voltage, surge voltage, for a few seconds without irreversible damage or cell open circuiting.

28.10.7 Supercapacitor general properties

i. **Uses:** Rather than operating as a main battery, supercapacitors are more commonly used as power and memory backup during short power interruptions. Another application is improving the power density, the current handling, of a battery. The supercapacitor is placed in parallel to the battery and provides current boost on high load demands. The supercapacitor can also fulfil the same role for portable fuel cells that have a lower power density than the battery. Because of its ability to rapidly charge - high power density - large supercapacitors can be used to store regenerative braking energy from electric/hybrid vehicles. Hundreds of supercapacitors are series and parallel connected to attain the required voltage, hence energy storage capacity. Some applications and range of ratings for supercapacitors are shown in Table 28.24.

Table 28.24: Super-capacitor ratings and applications

Energy kJ	Voltage V	Capacitance, ESR F, mΩ	Mass kg	Height @ dia 226 mm mm	Application
18.4	15	500, 2.4	5.1	W416.2 x D67.2 x L156.7	8-cylinder cars
60	28	153	38	560	heavy duty diesels
-	80	93.7, 11.3	-	W265 x D517 x L194	rail-road engines
90	300	2.0	38	560	power supplies
235.5	180	41.6, 28.8	85	W1077.2 x D484 x H256.6	pulse-power
6	300	0.13	10	300	electro-magnetic switches

Table 28.25 gives a summary of some critical properties of different energy source technologies. Because there are so many types with widely different properties, battery values are shown as a range. Supercapacitors have several advantages over batteries:

- indefinite number of charging and discharging cycles;
- maintenance free and safe;
- light weight;
- high-rate discharge – high power density;
- higher efficiency, with lower internal resistance;
- lower internal heating and much wider operating temperature range -50°C to 85°C;
- recharge quickly, since no slow chemical reaction involved; and
- no negative environmental impact.

Supercapacitors are more expensive than batteries and have a lower volumetric efficiency.

Supercapacitors have a higher energy density than the conventional capacitor and a higher power density than the electrochemical battery. The gravimetric energy density of the supercapacitor is 1Wh/kg to 10Wh/kg. Although this energy density is high in comparison to an electrolytic capacitor, as shown in figure 28.2, it represents only one-tenth that of the nickel-metal-hydride battery. Whereas the electrochemical battery delivers a near constant voltage in the usable energy spectrum, the charge-voltage of the supercapacitor is linear and drops uniformly from full voltage to near zero volts during a constant discharge current. Because of this, the supercapacitor is unable to deliver the full charge.

If, for example, a 12V lead-acid battery discharges to 9V before the equipment cuts off, the supercapacitor reaches the same voltage within the first quarter of the discharge cycle, with over half the energy remaining in the capacitor, and that being difficult to exploited.

To operate at higher voltages, supercapacitors, like Li-ion cells, are connected in series. Also, like Li-ion batteries, for the series connection of more than three capacitors, voltage balancing is required to prevent any cell from experiencing an over-voltage.

Supercapacitors are relatively expensive in terms of cost per Watt, hence it may be better to use a larger battery with extra cells. But the supercapacitor and electro-chemical battery are not necessarily alternatives, rather they are complementary.

Table 28.25: Storage cell comparison

Property	units	Supercapacitors	MP Capacitors	Micro-Fuel Cells	Batteries
Charge/Discharge Time	s	milliseconds to seconds	picoseconds to milliseconds	Typically 10 to 300 hrs. Instant charge (refuel).	1 to 10 hrs
Operating Temperature	°C	-40 to +85	-20 to +100	+25 to +90	-20 to +65
Operating Voltage	V	2.3-2.75 V/cell	6 to >800	0.6 V/cell	1.25 - 4.2V/cell
Capacitance	F	100 mF to > 2F	10 pF - 2.2 mF	N/A	N/A
Efficiency	%	90 to 95	99	50	90 to 95 (Li-ion)
Life/Cycles	hrs	>30,000 hrs ave $10^5 - 10^6$	> 10^5 cycles	1500 to 10^4 hrs	150 to 1500 cycles
Weight	kg	1 - 2 g	1 g - 10 kg	20 g to > 5 kg	1 g to > 10 kg
Gravimetric Power Density	kW/kg	10 to 100	0.25 to 10,000	0.001 to 0.1	0.005 to 0.4
Gravimetric Energy Density	Wh/kg	1 to 5	0.01 to 0.05	300 to 3000	8 to 600
Volumetric Energy Density	Wh/l	0.05-10 Wh/l			50-250 Wh/l
Pulse Load	A	< 100	< 1000	< 150 mA / cm ²	< 5
Pollution		none	none	none	Cd/Pb

General features of super-capacitors are highlighted in the following points.

Advantages

- High power density
- Wide operating temperature range, -50°C to over 85°C:
 - capacity increases with decreased temperature,
 - lifetime doubles with every 10°C decrease in operating temperature, and
 - lifetime increases with decreased operating voltage.
- Virtually unlimited cycle life - can be cycled millions of times.
- High rates of charge and discharge.
- Chargeable and operable at any voltage up to its voltage limit.
- Reversibility, but asymmetrical charging and discharging rates.
- Low impedance - enhances load handling when paralleled with a battery.
- Rapid load discharging, without thermal heat.
- Charge - discharge cycling efficiency of over 95%, but reduce with high power pulses.
- Rapid charging - charged in seconds.
- Simple charge methods - no full-charge detection is needed; no danger of overcharge, not affected by deep discharges. State of Charge only a function of voltage.
- Do not involve hazardous substances. Aluminium case, etc., (25% to 30% by weight) can be recycled.
- Can be stored, transport, etc., safely retaining zero charge, since hermetically sealed.
- Cost-effective energy storage - lower energy density is compensated by a high cycle count.
- Bipolar voltage energy storage.

Limitations

- Linear discharge voltage prevents use of the full energy spectrum. Stored charge highly dependant on operating voltage level.
- Low energy density - typically stores one-tenth the energy of an electrochemical battery.
- Cells are low voltage, 2½V to 3V, - serial connection for higher voltages.
- Internal short-circuiting rate increases as voltage rating increases.
- Voltage balancing is required if more than three capacitors are series connected.
- High self-discharge - the rate is considerably higher than an electrochemical battery.
- Life expectancy is decreased with increased humidity, temperature, and voltage.
- Possible susceptibility to resonant vibration modes.
- Generally restrict to cylindrical in shape. Typical shape form factor results in reduced volumetric densities.
- The enigma of high cost.

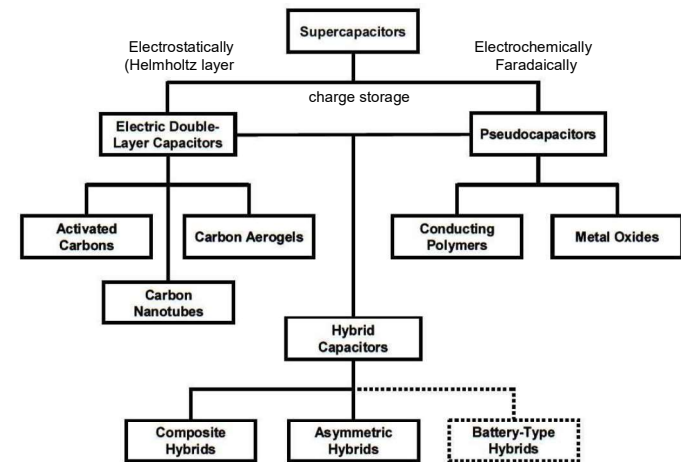

Figure 28.57. Supercapacitor family tree.

28.10.8 Pseudocapacitors

In contrast to EDLCs, which store charge electrostatically (in a Helmholtz layer), pseudocapacitors store charge electrochemically (Faradaically) through the transfer of charge between the electrode and electrolyte. This is accomplished through electrosorption, reduction-oxidation reactions, and intercalation processes. These Faradaic processes allow pseudocapacitors to achieve greater capacitances and energy densities than EDLCs.

There are two electrode materials used to store charge in pseudocapacitors, namely, conducting polymers and metal oxides, RuO₂ (rather than an activated carbon electrode material as in supercapacitors).

Conducting polymers have a relatively high capacitance and conductivity, plus a relatively low ESR and cost compared to carbon-based electrode materials. The n/p-type polymer configuration, with one negatively charged (n-doped) and one positively charged (p-doped) conducting polymer electrode, has greater potential energy and power densities; however, a lack of efficient, n-doped conducting polymer materials prevents pseudocapacitors from reaching their potential. The mechanical stress on conducting polymers during reduction-oxidation reactions limits the stability of pseudocapacitors through many charge-discharge cycles, thus hindering conducting polymer pseudocapacitor development.

Because of their high conductivity, *metal oxides*, particularly ruthenium oxide, is an electrode material used for pseudocapacitors. Other metal oxides attain lower capacitance. The capacitance of ruthenium oxide is achieved through the insertion and removal, termed intercalation, of protons into its amorphous structure. In its hydrous form, the capacitance exceeds that of carbon-based and conducting polymer materials. The ESR of hydrous ruthenium oxide is lower than that of other electrode materials. As a result, ruthenium oxide pseudocapacitors can achieve higher energy and power densities than similar EDLCs and conducting polymer pseudocapacitors, but at a prohibitive cost. The RC time constant is about 3s. [Typically a 300F hybrid battery/pseudocapacitor has an ESR of 18mΩ dc, 12mΩ @ 1kHz].

Example 28.7: Ultracapacitor constant current characteristics

A 3kF supercapacitor with an internal dc resistance of 0.29mΩ is charged to 2.7Vdc. Based on a series RC model for the supercapacitor:

- (a) if it is discharged from 2.7V at a constant 150A rate, determine:
- the initial stored energy;
 - the instantaneous initial output voltage and internal power losses;
 - an expression in time for the output voltage and ideal capacitor voltage, hence power
 - the final capacitor voltage, the time to reach this voltage, and the residual stored energy;
 - the energy dissipated in the internal resistance during the constant current discharge period; and
 - energy delivered to the constant current load, hence the overall efficiency of energy transfer.

- (b) if it is charged at a constant 150A rate from a residual voltage level of 1V to 2.7V, determine:
- the terminal voltage range to charge the capacitor;
 - the time to charge to 2.7V; and
 - the internal losses.

Solution

Figure 28.58. Solution to Example 28.7.



(a)

- i. The initial stored energy in the 3000F supercapacitor is

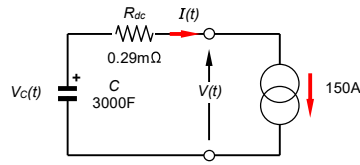
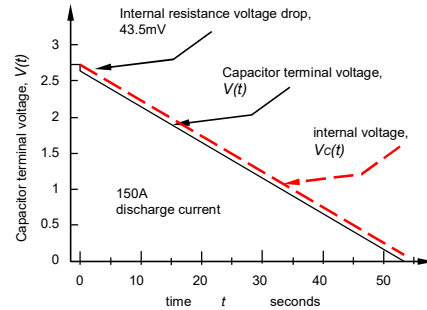
$$W_o = \frac{1}{2} C V_{co}^2$$

$$= \frac{1}{2} \times 3,000F \times 2.7^2 = 10.935kJ$$

- ii. The output voltage is the idea voltage minus the internal resistor voltage drop, that is

$$V(t=0) = V_{co} - IR_{dc}$$

$$= 2.7V - 150A \times 0.29m\Omega$$

$$= 2.7V - 43.5mV = 2.657V$$

Since the load current is constant, the internal resistor losses are constant, assuming the internal resistance does not increase due to temperature heating effects.

$$P_{R_{dc}} = I^2 R_{dc}$$

$$= 150^2 \times 0.29m\Omega = 6.525W$$

- iii. By Kirchhoff's voltage law, the capacitor terminal voltage is

$$V(t) = V_{co} - \frac{1}{C} \int Idt - IR_{dc}$$

$$= V_{co} - \frac{1}{C} I \times t - IR_{dc}$$

Since the discharge current is constant the ideal capacitor component discharges at a constant rate, being the first two terms on the right hand side of the above equation. The load absorbed power is

$$P(t) = I \times V(t) = I \times V_{co} - \frac{1}{C} I^2 \times t - I^2 R_{dc}$$

- iv. The constant current discharge ceases when the output voltage reaches zero, but the idea capacitor voltage is equal to the voltage drop across the internal resistance, that is

$$V(t_{dis}) = V_{co} - \frac{1}{C} I \times t_{dis} - IR_{dc} = 0$$

$$t_{dis} = \frac{V_{co} C}{I} - R_{dc} C = \frac{Q_{co}}{I} - \tau$$

$$= \frac{2.7V \times 3000F}{150A} - 0.29m\Omega \times 3000F$$

$$= 53.13s$$

such that

$$V_c(t_{dis}) = IR_{dc}$$

$$= 150A \times 0.29m\Omega = 43.5mV$$

The residual stored energy remaining in the ideal supercapacitor is

$$W(t_{dis}) = \frac{1}{2} C V_c^2 = \frac{1}{2} \times C \times (IR_{dc})^2$$

$$= \frac{1}{2} \times 3,000F \times 0.0435^2 = 2.838J$$

- v. The energy dissipated as heat in the internal resistance is 6.525W over 53.13s, that is, 346.67J.
- vi. The energy consumed by the constant current sink is 10,935J - 346.67J - 2.838J = 10,585.49J.

The system load efficiency is

$$\eta = \frac{W_{load}}{W_{load} + losses}$$

$$= \frac{10585.49J}{10585.49J + 346.67J} \times 100 = 96.83\%$$

The load energy transfer efficiency, the energy transferred to the load in terms of the available energy, is

$$\eta = \frac{W_{load}}{W_o}$$

$$= \frac{10,585.49J}{10,935J} \times 100 = 96.80\%$$

(b)

- i. The terminal voltage at the start of the charge period is

$$V = V_c + IR_{dc}$$

$$= 1.0V + 150A \times 0.29m\Omega = 0.044V$$

The terminal voltage at the end of the charge period is

$$V = V_c + IR_{dc}$$

$$= 2.7V + 150A \times 0.29m\Omega = 2.744V$$

- ii. The charge time is found by solving

$$2.7V = 1.0V + \frac{It}{C}$$

$$= 1.0V + \frac{150A \times t}{3000F}$$

which yields $t = 34s$.

- iii. The internal resistive losses are the power losses over 34s, that is

$$W_{R_{dc}} = I^2 R_{dc} t$$

$$= 150^2 \times 0.29m\Omega \times 34s = 221.85J$$

28.11 Thermoelectric modules

A thermoelectric module is a highly reliable, small, light, solid-state device that can operate as an electronic heat pump (a refrigerator) or as a low efficiency dc electrical power generator. When used to generate dc electricity, the module operates on the *Seebeck effect* and is called a thermoelectric generator, TEG. When used as a heat pump, the module utilizes the *Peltier effect* to remove heat and is called a thermoelectric cooler, TEC.

Dissimilar metals that are connected at two different locations (junctions) will develop a micro-voltage if the two junctions are held at different temperatures. The inverse is to apply a dc voltage, which causes a temperature difference between the junctions. This results in a compact heat pump, referred to as a thermoelectric cooler, TEC. In a thermoelectric material, there are free electrons or holes that carry both charge and heat.

A TEC can be used in applications where cooling or temperature control of an object is required. In general, a TEC can be used when an object:

- needs to be cooled below the ambient temperature, or
- is required to be maintained at a precise temperature under a fluctuating ambient temperature.

A TEC is ideal for cooling small, low heat load objects. Due to the low Coefficient of Performance, CoP, compared with compressor cooling, a TEC loses its advantage if the cooling load is higher than 300 W.

28.11.1 Theoretical background

The Seebeck coefficient is a material property that determines the performance of thermocouples and Peltier elements.

The *Seebeck effect* (or thermoelectric effect) is the direct conversion of heat energy into electrical energy, due to an emf developed due to a temperature difference between two junctions of dissimilar conductors in the same circuit. The Seebeck coefficient (or thermal emf coefficient) is related to the fact that electrons are carriers of both electricity and heat. When an electrical loop is made up with two

different metals (materials A and B), two junctions exist (1 and 2). If the junction temperatures (1 and 2) are different, a net EMF is produced and a current flows. s_A and s_B are the Seebeck coefficients of the materials (the equation in figure 28.59a is simplified as Seebeck coefficients are temperature dependant). The magnitude and sign of the Seebeck coefficient are related to an asymmetry of the electron distribution around the Fermi level. When two conductors with different Fermi levels make contact, electrons flow from the conductor with the higher Fermi level until the change in electrostatic potential, called contact potential, equalises the two Fermi levels. Typical Seebeck coefficient values for different materials are shown in Table 28.26.

The Peltier effect is manifested as heat pumping (moving heat energy from a cold place to a hotter one) by using electrical energy. Specifically the effect describes the liberation or absorption of heat at a contact where current passes from one material to another, whereby the contact becomes heated or cooled. If a voltage source is inserted and a current forced into the two-metal loop, one junction cools down while the other heats up. A similar equation applies in figure 28.59b and the cooling power P_e is proportional to the difference of Peltier coefficients of the two metals (π_A and π_B) and the current I . Typical Peltier factor values for different materials are shown in Table 28.27.

Peltier cooling/heating is the phenomenon of absorption/dissipation of heat by a junction between two dissimilar materials when electrical current flows through a junction. The Peltier coefficient is a measure of heat carried by electrons or holes.

The heat absorbed/dissipated P_p by a junction is

$$P_p = \pi \times I \tag{28.25}$$

where π is the temperature dependant Peltier coefficient, in V, corresponding to a specific pair of materials. The effect may be reversed wherein a change in the direction of electric current flow will reverse the direction of heat flow. Joule heating $I^2 \times R$, having an emf magnitude of $I \times R$ (where R is the electrical resistance of the semiconductors), also occurs in the conductors because of current flow. This Joule heating effect acts in opposition to the Peltier effect and causes a net reduction of the available cooling. Heat conducted from the hot junction, back to the cold junction also opposes the Peltier produced effect.

Seebeck power generation is a process by which heating/cooling of a junction of two dissimilar materials generates an electrical junction potential due to charge carrier diffusion and phonon drag:

$$\pi = s \times T \tag{28.26}$$

which relates the Seebeck and Peltier coefficients, where s is the Seebeck coefficient, V/K, and T is absolute temperature, K.

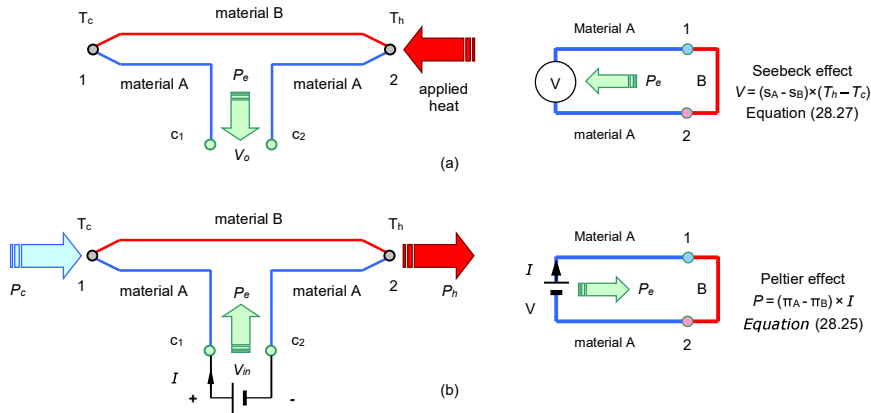

Figure 28.59. The (a) Seebeck and (b) Peltier effects.

The emf potential difference for the two junctions, with Seebeck coefficients s_n and s_p for n -type and p -type materials respectively, is

$$\Delta V = \int_{T_c}^{T_h} (s_p - s_n) dt = s \times (T_h - T_c) = s \times \Delta T \tag{28.27}$$

where T_{se} is the temperature of the absorbing/emitting junctions. The Seebeck coefficient is sometimes called the thermal emf coefficient or thermoelectric power.

When an electric current I is passed through a conductor having a temperature gradient over its length dT/dx , heat will be either absorbed by or dissipated from the conductor. Whether heat is absorbed or dissipated depends upon the direction of both the electric current and temperature gradient. This is known as the Thomson effect, τ , (which is insignificant in TE modules) and is described by

$$\frac{dP}{dx} = \tau I \frac{dT}{dx}$$

where dP/dx is the rate of the heating per unit length, W/m.

Table 28.26: Seebeck coefficients for Standard Thermocouples. The absolute value for Pt (specifically, 5 μ V/K) should be subtracted from each value listed.

type	couples	Seebeck coefficient, s
		μ V/K
E	Chromel - Constantan	60
J	Iron - Constantan	51
T	Copper - Constantan	40
K	Chromel -A	40
N	Nicrosil - Nisil	38
S	Pt (10% Rh) - Pt	11
B	Pt (30% Rh) - Pt (6% Rh)	8
R	Pt (13% Rh) - Pt	12

Table 28.27: Peltier factors, π , for different pairs of metals

Fe-constantan		Cu-Ni		Pb-constantan	
T	π	T	π	T	π
K	mV	K	mV	K	mV
273	13.0	292	8.0	293	8.7
299	15.0	328	9.0	383	11.8
403	19.0	478	10.3	508	16.0
513	26.0	563	8.6	578	18.7
593	34.0	613	8.0	633	20.6
833	52.0	718	10.0	713	23.4

The irreversible thermodynamic theory relating the three coefficients π , s , and τ is described by

$$\begin{aligned} \pi &= sT = s \frac{\Delta V}{\Delta T} \\ \tau &= T \frac{\delta s}{\delta T} \quad (V/K^2) \end{aligned} \tag{28.28}$$

The Peltier, Seebeck, and Thomson effects are reversible (in fact, the Peltier and Seebeck effects are reversals of one another); Joule heating and heat conduction are not reversible in complying with the laws of thermodynamics.

Thermoelectric modules for power semiconductor cooling are solid-state heat pumps that operate on the Peltier effect. A thermoelectric module consists of an array of p and n type narrow band gap, semiconductor element pairs that are heavily doped with electrical carriers. The elements are arranged into an array that is electrically connected in series but thermally connected in parallel. This array is then rigidly sandwiched between two thermally conducting and electrical insulating ceramic substrates, one on each side of the elements as seen in figures 28.60a and 28.61.

When current passes through the junction of two different types of conductors, a temperature change results at the junction. The practical application of this concept requires semiconductors that are good conductors of electricity but poor conductors of heat. Anisotropic orientated polycrystalline bismuth telluride is mainly used as the semiconductor material, heavily doped to create either an excess (n -type) or a deficiency (p -type) of electrons, as shown in figure 28.61.

When connected to a dc power source, current causes heat to move from one side of the TEC to the other. This creates a hot side and a cold side on the TEC. A typical cooling application exposes the cold side of the TEC to the object or substance to be cooled and the hot side to a heatsink which dissipates the heat to the environment. A heat exchanger with forced air or liquid is usually required. A thermoelectric cooler does not absorb heat, it only transfers or moves it. If the current is reversed, the heat is moved in the opposite direction. In other words, what was the hot face will become the cold face and vice-versa. Unlike a heat pipe, Peltier elements consume energy or produce heat. It is therefore possible to cool a device below ambient temperature, unlike a heat pipe. A heat exchanger with forced air or liquid may be required for both cooling mechanisms.

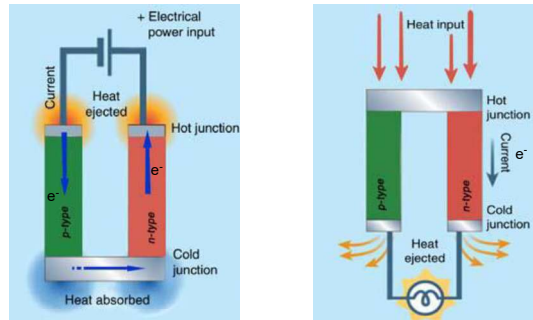

Figure 28.60. Schematic representations of a pn-couple used as: (a) a thermoelectric cooler TEC based on the Peltier effect or (b) a thermoelectric generator TEG based on the Seebeck effect.

The heat transfer occurs as electrons flow through one pair of p and n type elements (often referred to as a *couple*) within the thermoelectric module:

The *p*-type semiconductor is doped with specific atoms that have fewer electrons than necessary to complete the atomic bonds within the crystal lattice. When a voltage is applied, there is a tendency for conduction electrons to complete the atomic bonds. When conduction electrons do this, they leave 'holes' which essentially are atoms within the crystal lattice that now have local positive charges. Electrons are continually filling and being released from the holes and move on to the next available hole. In effect, the holes act as the electrical positive carriers.

Electrons move much more easily in the copper interconnect conductors but not so easily in the semiconductors. When electrons leave the *p*-type and enter the copper on the cold-side, holes are created in the *p*-type as the electrons jump to a higher energy level to match the energy level of the electrons already moving in the copper. The extra energy to create these holes comes by absorbing heat. Meanwhile, the newly created holes travel to the copper on the hot side. Electrons from the hot-side copper move into the *p*-type and fill the holes, releasing excess energy in the form of heat.

The *n*-type semiconductor is doped with atoms that provide more electrons than necessary to complete the atomic bonds within the crystal lattice. When a voltage is applied, these excess electrons are easily moved into the conduction band. However, additional energy is required to enable the *n*-type electrons to match the energy level of the incoming electrons from the cold-side copper. The needed energy is gained by absorbing heat. Finally, when the electrons leave the hot-side of the *n*-type, they once again move freely in the copper. They fall to a lower energy level, and release heat in the process.

The key fact is that heat is always absorbed at the cold side of the n and p type elements, and heat is always released at the hot side of thermoelectric element. The heat pumping capacity of a module is proportional to the current (equation (28.25)) and is dependent on the element geometry, number of couples, and material properties.

When a Peltier cell cooling system starts up, both cold and hot sides are at the same temperature, so ΔT is zero and the cell develops its maximum power. As the temperature difference across the cell increases, the cooling power decreases and temperatures stabilize. Targeted applications mainly operate at around room temperature.

Since Peltier elements are active heat pumps, they can be used to cool components below ambient temperature - which is not possible using conventional cooling, or even heat pipes.

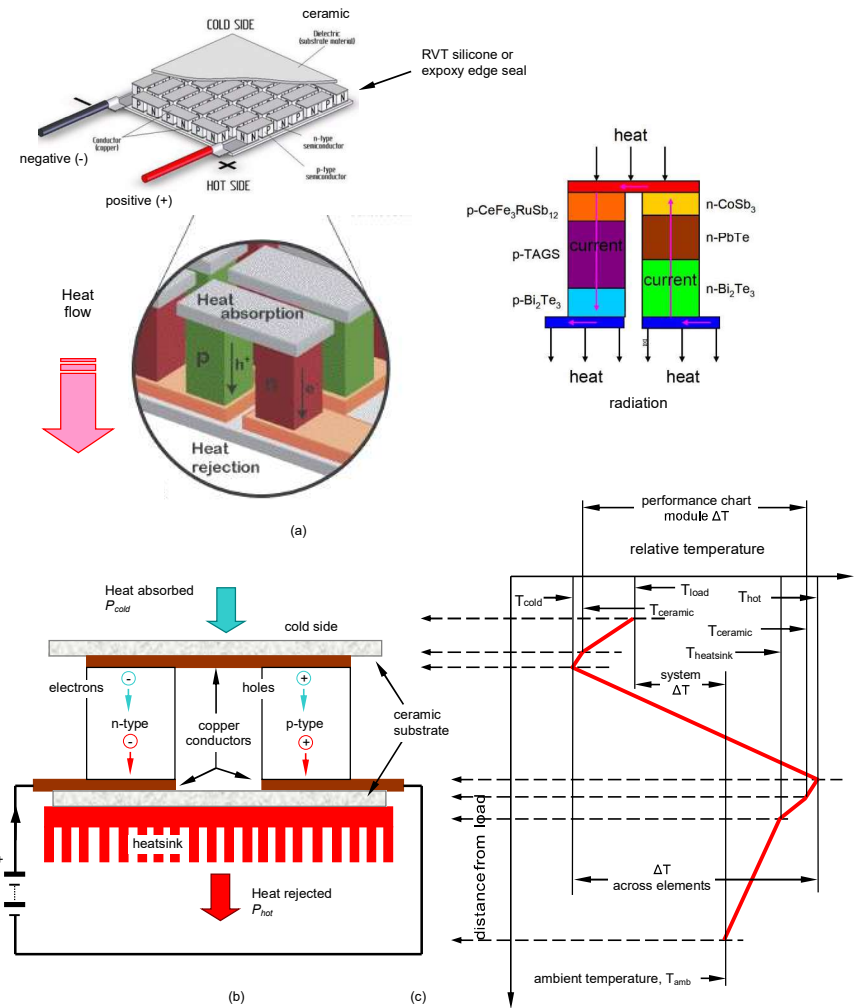

Figure 28.61. The thermoelectric cooler: (a) module; (b) Peltier principle; and (c) temperature profile.

28.11.2 Thermoelectric materials

The thermoelectric semiconductor material most often used in TE coolers is an alloy of Bismuth Telluride that has been suitably doped to provide individual blocks or elements having distinct n and p characteristics.

- i. *n*-type: bismuth-telluride-selenium ($\text{Bi}_2\text{Te}_3 / \text{Sb}_2\text{Se}_3$) compound:
Seebeck's coefficient at 300K: $s \geq (140 \text{ to } 180) \times 10^{-6} \text{ V/K}$
Specific conductivity at 300K: $\sigma = 1/\rho = (1300 \text{ to } 1700) \text{ Ohm}^{-1} \cdot \text{cm}^{-1}$

- ii. *p*-type: bismuth-telluride-antimony ($\text{Bi}_2\text{Te}_3/\text{Sb}_2\text{Te}_3$) compound:
Seebeck's coefficient at 300K: $s \approx (130 \text{ to } 170) \times 10^{-6} \text{ V/K}$
Specific conductivity at 300K: $\sigma = 1/\rho = (1400 \text{ to } 1800) \text{ Ohm}^{-1}\cdot\text{cm}^{-1}$

Seebeck coefficient values for different TE semiconductor materials are shown in Table 28.28.

Bismuth Telluride is a thermoelectric semiconductor material that exhibits optimum performance in a 'room temperature' range. Thermoelectric materials most often are fabricated by either directional crystallization from a melt or pressed powder metallurgy. Bismuth Telluride is highly anisotropic. Its electrical resistance is about four times greater parallel to the crystal growth axis than perpendicular to it. Advantageously, the growth axis thermal conductivity is about double that of the perpendicular axis. A high Figure of Merit arises in the parallel orientation because the anisotropic behaviour of resistance is greater than that of thermal conductivity.

In addition to Bismuth Telluride (Bi_2Te_3) and Lead Telluride (PbTe), there are other thermoelectric materials including, Silicon Germanium (SiGe), and Bismuth-Antimony (Bi-Sb) alloys that may be used in specific situations. Bi-Sb alloys perform better than Bi_2Te_3 at low temperatures, <200K, while Lead Telluride (PbTe) based thermoelectric materials are typically employed for operational temperature around 500K to 800K. Te-Ag-Ge-Sb materials have been developed to replace *p*-type PbTe . Silicon Germanium (SiGe) alloys, with boron and phosphorous (or arsenic) as *p*-type and *n*-type doping agent can be used up to 1300K, with a Figure of Merit Z approaching unity.

Table 28.28: Seebeck coefficients for some metals and alloys, compared to Platinum

metals	Seebeck coefficient	semiconductors	Seebeck coefficient
	s		s
	$\mu\text{V}/\text{K}$		$\mu\text{V}/\text{K}$
antimony	47	Se	900
nichrome	25	Te	500
molybdenum	10	Si	440
cadmium	7.5	Ge	300
tungsten	7.5	<i>n</i> -type Bi_2Te_3	-230
gold	6.5	<i>p</i> -type $\text{Bi}_{2-x}\text{Sb}_x\text{Te}_3$	300
silver	6.5	<i>p</i> -type Sb_2Te_3	185
copper	6.5	PbTe	-180
lead	4.0	$\text{Pb}_{0.3}\text{Ge}_{0.39}\text{Se}_{0.58}$	1670
aluminium	3.5	$\text{Pb}_{0.6}\text{Ge}_{0.36}\text{Se}_{0.58}$	1410
carbon	3.0	$\text{Pb}_{1.3}\text{Ge}_{0.29}\text{Se}_{0.58}$	-1710
mercury	0.6	$\text{Pb}_{1.5}\text{Ge}_{0.37}\text{Se}_{0.58}$	-1990
platinum	0	SnSb_4Te_7	25
sodium	-2.0	SnBi_4Te_7	120
potassium	-9.0	$\text{SnBi}_5\text{Sb}_1\text{Te}_7$	151
nickel	-15	$\text{SnBi}_{2.5}\text{Sb}_{1.5}\text{Te}_7$	110
constantan	-35	$\text{SnBi}_2\text{Sb}_2\text{Te}_7$	90
bismuth	-72	PbBi_4Te_7	-53

Figure 28.62 illustrates the relative performance or Figure-of-Merit of various materials over a range of temperatures. The performance of Bismuth Telluride peaks within a temperature range that is best suited for most room temperature cooling applications.

Ceramic TE components are made of beryllium oxide, BeO , which is typically used in multi-stage coolers due to its higher thermal conductivity. The advantages of this material are that it enhances the thermal performance of the TE Cooler because of the high heat conductance as well as makes it easier to assemble. Disadvantages are that it is more expensive and can be toxic when its processing dust is inhaled. Aluminium oxide Al_2O_3 and particularly, aluminium nitride AlN , are viable ceramic alternatives, with properties as shown in Table 28.29.

The most common TEC shape is a square or a rectangular substrate device. The practical size of a single stage TEC ranges from 3mm x 3mm up to 60mm x 60mm. A size limitation of 60mm x 60mm is due to the thermal stress from thermal expansion deformations between the cold and the hot junctions of the TEC. To obtain a larger temperature difference (but not higher cooling powers), a multistage cascaded TEC can be built, where 6 stages is the maximum practical limit.

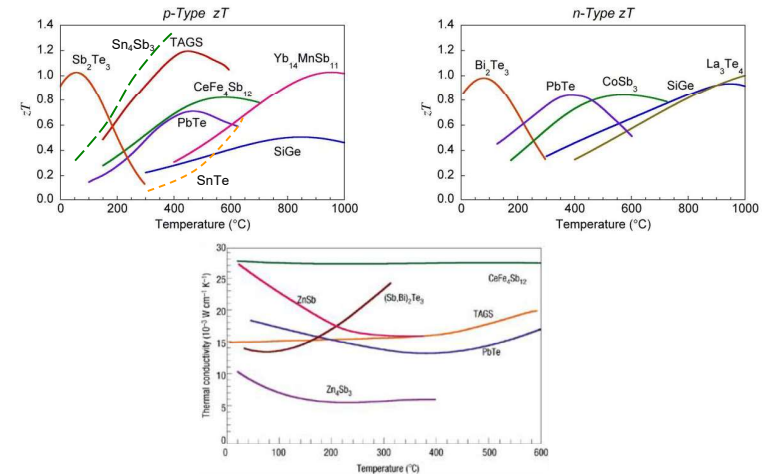

Figure 28.62. Performance of thermoelectric materials at various temperatures. TAGS (Te-Ag-Ge-Sb)

Table 28.29: TEC/TEG substrate properties (also see tables 5.13 to 5.15)

Materials	Density	Thermal Conductivity	Coeff. of thermal expansion	Specific heat	Electric Resistivity 25°C	Dielectric strength ac	Dielectric loss 25°C@1MHz	Dielectric Constant @ 1 MHz	Poisson's Ratio
	g/cm^3	$\text{W}/\text{m}\cdot\text{K}$	$10^{-6}/\text{K}$	$\text{J}/\text{kg}\cdot\text{K}$	$\text{Ohm}\cdot\text{m}$	kV/mm	$\times 10^{-4}$		
Alumina 99.5% Al_2O_3	3.89	35	8.4	880	$> 10^{12}$	8.7	1	9.8	0.22
Beryllia BeO	2.85	248	7.2	1260	10^{15}			6.5	0.38
Aluminium Nitride AlN	3.26	140 - 180	4.5	740	$> 10^{12}$	15	1	9	0.24

28.11.3 Mathematical equations for a thermoelectric module

A thermoelectric couple is shown in figure 28.63, on which the following physical and electrical parameters are defined.

- L = element height, m
- A = cross-sectional area, m^2
- G = Area / Length (inverse of aspect ratio) of TE Element, m
- P_c = heat load on the cold side (into and pumped by the TEC), W
- P_h = heat released from the hot side (pumped from the TEC), W
- P_{tec} = electrical input power (heat load) to the thermoelectric, W
- T_c = cold-side temperature, K
- T_h = hot-side temperature, K
- $\Delta T = T_h - T_c$, K
- $T_{\text{ave}} = \frac{1}{2} \times (T_c + T_h)$, K
- I_{te} = applied current, A

Additionally

s = Seebeck coefficient, V / K
 ρ = electrical resistivity, Ωm (electrical conductivity $\sigma = 1/\rho$)
 κ = thermal conductivity, W/m K
 V = input dc voltage, V
 N = number of thermocouples, element pairs, odd

CoP Coefficient of Performance (P_c / IV)
 Z Figure of Merit ($s^2 / \rho \times \kappa$), 1/K
 S Device Seebeck Voltage ($2N \times s$), V / K
 R Device Electrical Resistance ($2N \times \rho / G = 2N \times \rho \times L / A = \Delta V / \Delta I$), Ohms
 K Device Thermal Conductance ($2N \times \kappa \times G = 2N \times \kappa \times A / L$), W / K

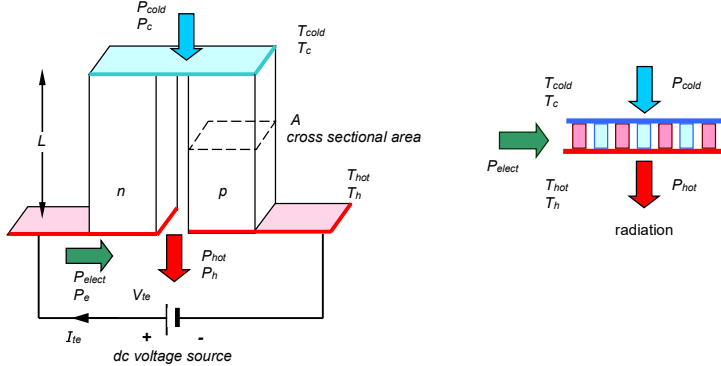

Figure 28.63. The thermoelectric couple based on the Peltier effect.

The heat pumped at the cold surface P_c is

$$P_c = 2 \times N \times \left[sIT_c - \frac{1}{2}I^2 \frac{\rho}{G} - \kappa G \Delta T \right] \quad (\text{W}) \quad (28.29)$$

- The first P_c term, $s \times I \times T_c$, is the Peltier cooling effect.
- The second term, $\frac{1}{2} \times I^2 \times \rho \times L / A$, represents the Joule heating effect ($I^2 \times R$) associated with passing an electrical current through resistance. The Joule heat is distributed throughout the element, so that half the heat goes towards the cold side, and the remaining half of the heat goes towards the hot side.
- The last term, $\kappa \times A / L \times (T_h - T_c)$, represents the Fourier heat effect in which heat conducts from a higher temperature to a lower temperature.

Peltier cooling is reduced by the losses associated with electrical resistance and thermal conductance.

The heat dissipated from the hot side P_h is

$$P_h = 2 \times N \times \left[sIT_h + \frac{1}{2}I^2 \frac{\rho}{G} - \kappa G \Delta T \right] \quad (\text{W}) \quad (28.30)$$

The electrical input power applied to the TEC, P_e , is the difference between the hot and cold powers, that is

$$P_e = P_h - P_c = 2 \times N \times \left[sIT_h + I^2 \frac{\rho}{G} \right] = V \times I \quad (\text{W}) \quad (28.31)$$

The input terminal voltage to the module is therefore P_e / I

$$V = 2 \times N \times \left[s \times \Delta T + I \times \frac{\rho}{G} \right] \quad (\text{V}) \quad (28.32)$$

In the voltage equation, the first term, $s \times (T_h - T_c)$ represents the Seebeck voltage. The second term, $I \times \rho \times L / A$ represents the electrical voltage related by Ohm's law.

The heat rejected by the module P_{hot} is

$$P_{hot} = P_{cold} + P_{tec} \quad (\text{W}) \quad (28.33)$$

The Coefficient of Performance, CoP, is useful in selecting a module (the larger CoP the better), and is defined by

$$CoP = \frac{\text{heat absorbed at the cold junction}}{\text{electrical dc input power}} = \frac{P_{cold}}{V_{te} \times I_{te}} = \frac{P_{cold}}{P_{tec}} \quad (28.34)$$

where I_{te} is the current drawn by the TE module

V_{te} is the voltage applied to the TE module

A maximum CoP represents the minimum input dc power P_{tec} , therefore minimum total heat to be rejected by the heat exchanger on the hot side P_{hot} , that is $P_{hot} = P_{cold} + P_{tec}$.

A physical properties materials figure-of-merit is

$$Z = \frac{s^2}{\rho \times \kappa} \quad (\text{K}^{-1}) \quad (28.35)$$

The figure-of-merit Z is directly related to TEC module ability to pump heat. This equation shows why it is difficult to obtain good thermoelectric materials. A good thermoelectric material must achieve low thermal conductivity κ (to prevent heat losses through heat conduction between the hot and cold side) and a high electrical conductivity $\sigma = 1/\rho$ (to minimize Joule heating).

Equations (28.29), (28.32), and (28.35) can be simplified by substituting $S = 2N \times s$, $R = 2N \times \rho / G$ and $K = 2N \times \kappa \times G$, as appropriate.

$$P_c = SIT_c - \frac{1}{2}I^2 R - K \times \Delta T \quad (\text{W}) \quad (28.36)$$

$$V = S \times \Delta T + I \times R \quad (\text{V}) \quad (28.37)$$

$$Z = \frac{S^2}{R \times K} \quad (\text{K}^{-1}) \quad (28.38)$$

S , R and K are not usually given by manufacturers. Rather they are derived from the given parameters I_{opt} , V_{opt} , P_{max} , and T_{max} , at a specified T_h .

Expressions for I_{opt} , V_{opt} , P_{max} , and T_{max}

The maximum heat pumping rate is derived from the differential of equation (28.36) with respect to I at zero P_c , which gives an optimum current of

$$I_{opt} = \frac{S}{R} \times T_c = \frac{S}{R} \times (T_h - \Delta T_{max}) \quad (28.39)$$

Substituting I_{opt} into equation (28.36) gives the maximum heat pumping rate, $P_{c,max}$

$$P_{c,max} = \frac{1}{2} \frac{S^2 \times T_c^2}{R} - K \Delta T \quad (\text{W}) \quad (28.40)$$

The peak maximum is when $\Delta T = 0$, that is

$$P_{c,max} = \frac{1}{2} \frac{S^2 \times T_c^2}{R} \quad (28.41)$$

The corresponding CoP is

$$CoP_{opt} = \frac{\frac{1}{2} Z T_c^2 - \Delta T}{Z T_h T_c} \quad (28.42)$$

and from equation (28.38)

$$ZT = \frac{S^2 T}{R \times K} \quad (28.43)$$

From equation (28.40) the largest temperature difference occurs when $P_{c,max}$ is zero, whence the maximum temperature difference is

$$\Delta T_{max} = \frac{1}{2} \frac{S^2}{K \times R} \times T_c^2 = \frac{1}{2} Z \times T_c^2 = \frac{1}{2} Z \times (T_h - \Delta T_{max})^2 \quad (28.44)$$

or in terms of only the hot side temperature, ΔT_{max} from equation (28.44) and I_{opt} from equation (28.39) become

$$\Delta T_{max} = T_h - \frac{(1 + 2 \times Z \times T_h)^{1/2} - 1}{Z} \quad (28.45)$$

$$I_{opt} = \frac{\kappa \times G}{S} \times \left[(1 + 2 \times Z \times T_h)^{1/2} - 1 \right] = \frac{K}{S} \times \left[(1 + 2 \times Z \times T_h)^{1/2} - 1 \right] \quad (28.46)$$

From equation (28.37) the optimum voltage for a maximum temperature differential is therefore

$$V_{opt} = S \times \Delta T_{max} + I_{opt} \times R \quad (\text{V}) \quad (28.47)$$

Calculation of Z , S , K , and R from data sheet information:

$$\begin{aligned} Z &= \frac{2\Delta T_{max}}{(T_h - \Delta T_{max})^2} \\ S &= \frac{2 \times V_{opt}}{T_h} = \frac{2 \times P_{max}}{(T_h - \Delta T_{max}) \times I_{opt}} \\ K &= \frac{(T_h - \Delta T_{max}) V_{opt} I_{opt}}{2T_h \Delta T_{max}} = \frac{(T_h - \Delta T_{max}) P_{max}}{(T_h + \Delta T_{max}) \Delta T_{max}} \\ R &= \frac{(T_h - \Delta T_{max}) \times V_{opt}}{T_h \times I_{opt}} = \frac{S^2}{K \times Z} \end{aligned} \tag{28.48}$$

If N and G are known, s , ρ and κ can be calculated.

From equations (28.36) and (28.37) the CoP , equation (28.34), is now given by

$$CoP = \frac{P_c}{P_e} = \frac{SIT_c - K\Delta T - \frac{1}{2}I^2R}{SI\Delta T + I^2R} \tag{28.49}$$

Differentiation of the CoP equation with respect to the current term, $dCoP/dI=0$, gives:

Optimum Current:

$$I_{CoP,opt} = \frac{S\Delta T}{R(1 + Z \times T_{ave})^{1/2} - 1} \times \frac{\kappa \times G}{s} \times \frac{\Delta T}{T_{ave}} \times \left[(1 + 2 \times Z \times T_h)^{1/2} + 1 \right] \tag{28.50}$$

The corresponding maximum CoP , (calculated at I_{opt}):

$$CoP_{max} = \frac{P_c}{VI} = \frac{T_c}{\Delta T} \times \frac{(1 + Z \times T_{ave})^{1/2} - \frac{T_h}{T_c}}{(1 + Z \times T_{ave})^{1/2} + 1} \times \frac{T_{ave}}{\Delta T} \times \frac{(1 + Z \times T_{ave})^{1/2} - 1}{(1 + Z \times T_{ave})^{1/2} + 1} - \frac{1}{2} \tag{28.51}$$

For a given thermoelectric material, equation (28.51) can be used to plot the maximum CoP as a function of the thermoelectric element ΔT ($T_h - T_c$). This is illustrated in figure 6.43a for Bismuth Telluride (Bi_2Te_3) thermoelectric materials. CoP s in excess of one are possible for ΔT 's less than about $30^\circ C$. The CoP increases significantly for systems designed to run optimally at even lower ΔT 's.

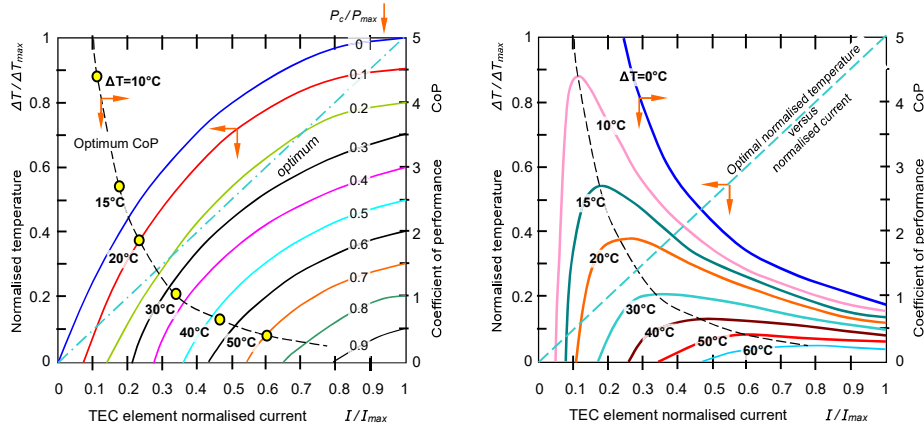

Figure 28.64. TEC:

(a) generic performance curve and (b) theoretical optimum (maximum) CoP as a function of current.

Operation at near rated maximum current potentially results in significantly degraded performance as illustrated in figure 28.64b, which shows a plot of CoP as a function of the percentage of maximum rated current (I/I_{max}).

The peak CoP for each of the curves coincides with the single curve of figure 5.59a. Each curve represents a TEC optimized for that particular ΔT and then operated at various different currents from 0 to I_{max} . For a given curve, the CoP decreases significantly as the TEC is operated 'off-optimum', especially for ΔT 's less than $30^\circ C$.

Figure 28.64b shows that the current required to produce high CoP 's is a low percentage of the TEC rated maximum current (10 to 15% of I_{max}). In other words, the TEC must pump the desired heat while 'idling' at a low percentage of I_{max} in order to achieve high CoP 's.

The CoP of an n -stage, $n > 1$, thermoelectric module can be expressed as

$$CoP_n = \frac{1}{\left(1 + \frac{1}{n \times (CoP_1 + 1/2) - 1/2} \right)^n} - 1 \tag{28.52}$$

assuming that each stage operates over a temperature difference of $\Delta T/n$ and CoP_1 is applicable to a single stage TEC that operates over ΔT . For example, the CoP of a two-identical-stage module is

$$CoP_2 = CoP_1 + \frac{1}{8 \times (2 \times CoP_1 + 1)}$$

The presented equations are simplified but show the basic idea behind the calculations involved. The actual differential equations do not have a closed-form solution because S , R , and K are temperature dependent. Assuming constant properties can lead to significant errors.

28.11.4 Features of thermoelectric cooling - Peltier elements

The use of thermoelectric modules often provides solutions, and in some cases the only solution, to many difficult thermal management problems where a low to moderate amount of heat must be handled. While no one cooling method is ideal in all respects and the use of a thermoelectric module will not be suitable for every application, TE coolers will often provide substantial advantages over alternative technologies. TE Coolers typically have a CoP of approximately 2, which is lower than the CoP of 3 to 5 of vapour compression refrigerators.

The lowest practically achievable temperature is about $-100^\circ C$, since the efficiency of thermoelectric modules decreases considerably at very low temperatures. The highest practical temperature is about $80^\circ C$, which is imposed by the manufacturing techniques used to assemble thermoelectric modules.

Some of the more significant features of thermoelectric modules include:

Compared with standard designs using refrigeration cycles with compressors and cooling mediums (such as CFC's), thermoelectric cooling possesses the following traits:

- There is no environmental damage since no cooling medium such as CFCs or any gas is used. Environmentally friendly and safe. No coolant gas, corrosive gas or fluid leakage, easy minimal maintenance.
- Small compact size - dimensions (small form factor) and lightweight, giving high cooling density.
- Wide choice of configuration – flexible form.
- $V-I$ controllable with fast, dynamic response. By simply changing the applied dc current polarity, heating is possible in addition to cooling with the same module (including temperature cycling). Easy switching from cooling to heating mode. Since cooling and heating are both possible, it is also possible to regulate temperatures close to room temperature. Precise temperature control to within $\pm 0.1^\circ C$, with smooth and fine adjustment of cooling capacity and temperature.
- DC operation, with high power efficiency.
- Good responsiveness to heat. (Quickly heats or cools.) Quick cooling to below ambient - economically. Wide operating temperature range, sub-ambient cooling, cooling to low temperatures, below ambient, multistage cascades to below $-100^\circ C$, wide range of operating temperatures.
- Solid-state device, therefore no moving parts; there is no vibration or noise. Acoustically silent and electrically 'quiet'.
- Since there are no fatiguing or breakable machine parts it is the most long-lasting, highly reliable method of cooling. Maintenance-free, MTBF $> 200,000$ hr.
- With only a power cord, it is easy to handle.
- Spot Cooling: It is possible to cool one specific component or area only, thereby often making it unnecessary to cool an entire package or enclosure.
- Operation in any orientation or any spatial position, zero gravity and high G levels, resistance to high mechanical loads, shocks and vibration.

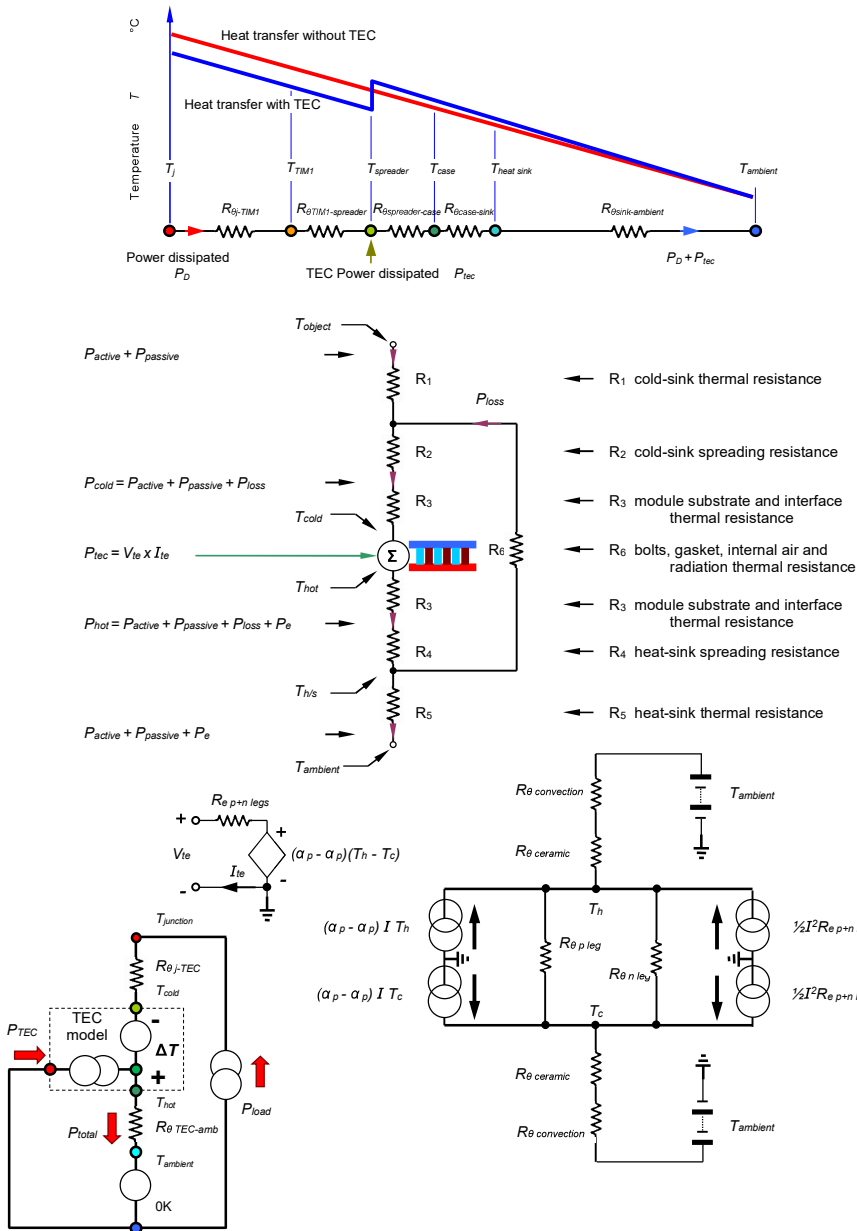

Figure 28.65. TEC cooling models: (a) thermal resistance model; (b) equivalent electrical circuit models; & (c) PSpice electrical model.

Problems related to Peltier cooling

- High power usage and high power dissipation are the biggest problems related to Peltier cooling. Large power dissipation requires a large heatsink, powerful (and thus loud) fans, and a dc supply.
- Limited to power dissipation of the order of 600W.
- Low temperatures may cause moisture condensation, leading to short circuits between the elements. Moisture condensation depends on the temperature inside the system block, the temperature of the cooled device and air moisture. The warmer the air and the higher the moisture, the more probable condensation occurs.
- Low efficiency, or low CoP compared with compressor-based cooling.
- Failure modes are thermal cycle fatigue of solder to chip, copper corrosion, copper migration, and crystal inclined cleavage planed defects.

28.11.5 TE cooling design

TEC design involves the initial specification of three parameters, the hot and cold side temperatures, T_{hot} and T_{cold} , (or T_h and T_c) hence the temperature gradient or difference $\Delta T = T_h - T_c$, ($\Delta T > 0$) and the amount of heat, in Watts, to be absorbed at the cold surface of the TEC, P_{cold} . The cold surface temperature, T_c , is the desired temperature of the object to be cooled, directly in contact with the TEC.

The hot surface temperature, T_h , is defined by two major parameters:

- The temperature of the ambient environment to which the heat is being rejected.
- The efficiency of the heat exchanger that is between the hot surface of the TEC and the ambient.

The third parameter required is the amount of heat, the thermal load, P_{cold} , to be removed or absorbed by the cold surface of the TEC. The thermal load includes the active I^2R type losses of the device to be cooled, as well as parasitic loads such as conduction through any mechanical object in contact with both the cold surface and any warmer environment, like conduction through mounting bolts and plates (and the radiation from the plates). Figure 28.65 shows the thermal resistance components and the system model.

Performance characteristic and design charts, as in figure 28.66, are provided. These allowing the terminal dc voltage and dc current requirements to be determined from the temperature difference ΔT and heat to be absorbed on the cold side, P_{cold} . The maximum ΔT is about 67°C for a single TEC, higher than this requires cascading (stacking) of TECs. TE technical details can be found in Chapter 6.13.1. The negative quadratic shape in the lower plot on figure 6.41, represents the optimal operating curve.

Example 28.8: Thermoelectric cooler design

An application has an estimated heat load of 22W, a forced convection type heat sink with a thermal resistance of 0.15°C/W, in an ambient temperature of 25°C, and an object that needs to be cooled to 5°C. The cold side of the thermoelectric cooler is in direct contact with the object to be cooled. The specifications for the thermoelectric module in figure 28.66 are as follows (at $T_h = 25^\circ\text{C}$):

- $I_{max} = 6.0\text{A}$
- $Q_{max} = 51.4\text{W}$
- $V_{max} = 15.4\text{V}$
- $\Delta T_{max} = 67^\circ\text{C}$

Solution

To determine if the thermoelectric cooler is appropriate for this application, it must be shown that the parameters ΔT and Q_c are within the appropriate boundaries of the performance curves.

The parameter ΔT follows directly from T_h and T_c . Since the cold side of the thermoelectric is in direct contact with the object being cooled, T_c is estimated to be 5°C. Assuming a 10°C rise above ambient for the forced convection type heat sink, T_h is estimated to be 35°C. Without knowing the power into the thermoelectric cooler, an exact value of T_h cannot be found initially. The temperature difference across the thermoelectric cooler is:

$$\Delta T = T_h - T_c = 35^\circ\text{C} - 5^\circ\text{C} = 30^\circ\text{C}$$

Figure 28.66 shows performance curves for the TEC at a hot side temperature of 35°C. Referring to figure 28.66b, the intersection of $P_c = 22\text{W}$ and $\Delta T = 30^\circ\text{C}$ show that this thermoelectric can pump 22W of heat at a ΔT of 30°C with an input current of 3.6A.

These values are based on the estimate $T_h = 35^\circ\text{C}$. Once the power into the TEC is determined, the equations to follow can be used to solve for T_h and to determine whether the original estimate of T_h was appropriate.

The input power to the thermoelectric, P_{in} , is the product of the current and the voltage. Using the 3.6A line in figure 28.66a for the current, the input voltage corresponding to $\Delta T = 30^\circ\text{C}$ is almost 10V. T_h can now be calculated from:

$$P_h = P_c + P_{rec} = 22\text{ W} + 3.6\text{ A} \times 10\text{ V} = 22\text{ W} + 36\text{ W} = 58\text{ W}$$

Therefore, using

$$T_h = T_{amb} + R_{\theta} \times P_h \text{ where } T_{amb} = 25^\circ\text{C} \text{ and } R_{\theta} = 0.15^\circ\text{C/W}$$

$$T_h = 25^\circ\text{C} + 0.15^\circ\text{C/W} \times 58\text{ W}$$

$$= 25^\circ\text{C} + 8.7^\circ\text{C} = 33.7^\circ\text{C}$$

The calculated T_h (33.7°C) is close enough to the original estimate of T_h (35°C), to conclude that the thermoelectric will work in the given application. If an exact solution is required, the process of solving for T_h mathematically can be repeated until the value of T_h does not change. The TEC operating coefficient of performance CoP is

$$CoP = \frac{P_{cold}}{P_{rec}} = \frac{22\text{ W}}{36\text{ W}} = 0.61$$

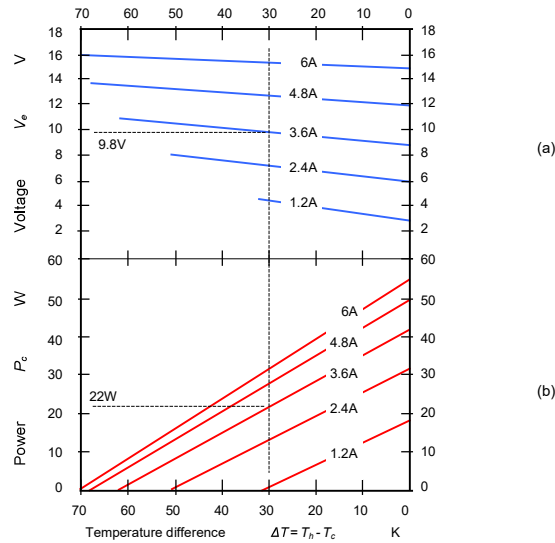

Figure 28.66. TEC performance curves: (a) upper plot ΔT versus Voltage and (b) lower plot, ΔT versus P_c .

28.11.6 Thermoelectric power generation

A thermoelectric generator, TEG, is an energy conversion system that converts thermal energy to electrical energy. The fundamental physics of this type of energy conversion is summarize as, the temperature difference ΔT between the hot T_h and cold T_c sources leads to a difference in the Fermi energy ΔE_F across the thermoelectric material yielding a potential difference, which drives a current. Bismuth Telluride-based thermoelectric modules are designed primarily for cooling or combined cooling and heating applications where electrical power creates a temperature difference across the module. By using the modules 'in reverse', however, whereby a temperature differential is applied across the faces of the module, it is possible to generate electrical power. Although power output and generation efficiency are low, useful power may be obtained where a source of heat is available. A thermoelectric module used for power generation has certain similarities to a conventional thermocouple. A single thermoelectric couple or generator with an applied temperature difference is shown in figure 28.67.

With no load (R_L not connected), the open circuit voltage as measured between points 'a' and 'b' is:

$$V_{o/c} = s \times \Delta T$$

where: $V_{o/c}$ is the output voltage from the couple (generator), V
 s is the average Seebeck coefficient, V/K

ΔT is the temperature difference across the couple where $\Delta T = T_h - T_c$, K

When a load is connected to the thermoelectric couple, the output voltage V_o drops as a result of internal couple thermoelectric materials resistance.

$$V_o = s \times \Delta T - I_{te} \times R_c \tag{28.53}$$

The current through the load is:

$$I_{te} = \frac{s \times \Delta T}{R_c + R_L} \tag{28.54}$$

where: I_{te} is the couple output current, A

R_c is the average internal resistance of the thermoelectric couple, Ω

R_L is the load resistance, Ω

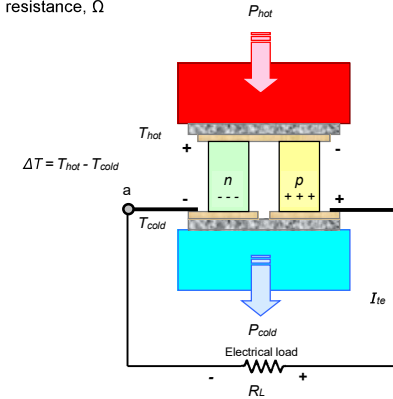

Figure 28.67. Single thermoelectric couple where $T_{hot} > T_{cold}$.

The output power, in terms of the input heat P_T and efficiency η , is given by

$$P_{rec} = I_{te} V_o = \eta P_T$$

Maximum efficiency is reached when the load and internal resistances are equal because this is the maximum power achievable from load matching.

The total heat input to the couple, P_h , is:

$$P_h = s \times T_h \times I_{te} - 1/2 \times I_{te}^2 \times R_c + k \times \Delta T \tag{28.55}$$

where: P_h is the heat input, W

k is the thermal conductance of the couple, W/K

T_h is the hot side of the couple, K

The efficiency of the couple η , is:

$$\eta = \frac{V_o \times I_{te}}{P_h} \tag{28.56}$$

A complete module consists of a number of couples, it is therefore necessary to rewrite the various equations for an actual module, as follows:

$$V_{o/c} = S \times \Delta T = I_{te} \times (R + R_L) \tag{28.57}$$

where: $V_{o/c}$ is the generators open circuit output voltage, V

S is the module's average Seebeck coefficient, V/K

R is the module's average resistance, Ω

The module Seebeck coefficient, resistance, and thermal conductance properties are temperature dependent. The values of S , R , and k must be selected at the average module temperature T_{ave} where:

$$T_{ave} = 1/2(T_h + T_c) \tag{28.58}$$

The power output, P_o , from the module in watts is:

$$P_o = R_L \times I_{te}^2 \tag{28.59}$$

The voltage at maximum power is half the open circuit voltage $V_{o/c}$ ($V_{o/c} = S \times \Delta T = 2V_{max}$) and the maximum power changes with temperature difference as a function of ΔT^2 .

$$P_{max} = \frac{V_{max}^2}{R} = \frac{V_{o/c}^2}{4R} = \frac{S^2 \times \Delta T^2}{4R} \tag{28.60}$$

The maximum efficiency of a thermoelectric material depends on two terms. The first is the Carnot efficiency: no heat engine can exceed the Carnot efficiency. The second is a term that depends on the thermoelectric properties, Seebeck coefficient, electrical resistivity, and thermal conductivity, which together form a material property called zT , which is a good approximation for the thermoelectric module Figure of Merit ZT . For small temperature difference ($T_c \approx T_h$) this efficiency is given by:

$$\eta_{max} = \frac{\Delta T}{T_h} \times \frac{\sqrt{1+ZT}-1}{\sqrt{1+ZT}+\frac{T_c}{T_h}} \approx \frac{\Delta T}{T_h} \times \frac{\sqrt{1+ZT}-1}{\sqrt{1+ZT}+1} \tag{28.61}$$

where

$$ZT = \frac{S^2 T}{RK} = \text{module figure of merit} \approx zT = \frac{S^2 T}{\rho \kappa} = \text{material figure of merit} \tag{28.62}$$

and

$$\frac{\Delta T}{T_h} = \text{Carnot efficiency} \tag{28.63}$$

ZT (involving S , K , and R) refers to the TEC module while zT (involving s , κ , and ρ) refers to the raw material property. That is, S , K , and R involve TEC dimensions and the number of couples.

Most thermoelectric generators contain a number of individual modules which may be electrically connected in either a series, parallel, or series/parallel arrangement. A typical generator configuration is illustrated in figure 28.68. This generator has a total number of modules N_T with N_s modules connected in series and N_p modules connected in parallel. The total number of modules in the system is:

$$N_T = N_s \times N_p \tag{28.64}$$

The current I in amperes passing through the load resistance R_L is:

$$I = \frac{N_s \times S \times \Delta T}{\frac{N_s}{N_p} \times R + R_L} = \frac{V_{o/c}}{R_{gen} + R_L} \tag{28.65}$$

where the open circuit output voltage $V_{o/c}$ is:

$$V_{o/c} = N_s \times S \Delta T \tag{28.66}$$

and the generator Thevenin equivalent resistance R_{gen} is:

$$R_{gen} = \frac{N_s}{N_p} \times R \tag{28.67}$$

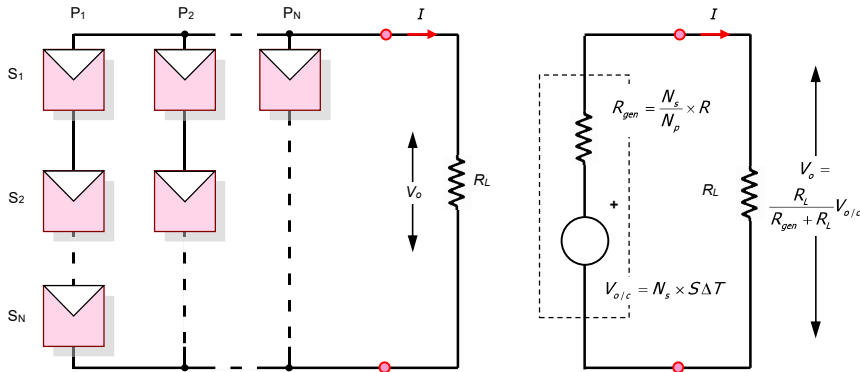

Figure 28.68. Typical thermoelectric generator with a series-parallel arrangement of modules.

The loaded output voltage V_o from the generator in volts is:

$$V_o = V_{o/c} \frac{R_L}{R_{gen} + R_L} = N_s \times S \Delta T \frac{R_L}{\frac{N_s}{N_p} \times R + R_L} \tag{28.68}$$

The output power P_o from the generator in watts is:

$$P_o = I^2 R_L = \left(\frac{N_s \times S \times \Delta T}{\frac{N_s}{N_p} \times R + R_L} \right)^2 R_L \tag{28.69}$$

The heat input P_h to each module in watts is:

$$P_h = S \times T_h \times \frac{I}{N_p} - \frac{1}{2} \times \left(\frac{I}{N_p} \right)^2 \times R + K \times \Delta T \tag{28.70}$$

The total heat input P_h to the generator in watts is:

$$P_h = N_T \times \left(S \times T_h \times \frac{I}{N_p} - \frac{1}{2} \times \left(\frac{I}{N_p} \right)^2 \times R + K \times \Delta T \right) \tag{28.71}$$

$$= N_s \times S \times T_h \times I - \frac{1}{2} \times I^2 \times \frac{N_s}{N_p} \times R + N_T \times K \times \Delta T$$

The efficiency η of the generator is:

$$\eta = \frac{P_o}{P_h} \times 100\%$$

Maximum efficiency occurs when the generator internal resistance R_{gen} equals the load resistance R_L . That is, from equation (28.67), maximum output power occurs when

$$R_L = R_{gen} = \frac{N_s}{N_p} \times R \tag{28.72}$$

Assuming temperature independent material parameters, the maximum efficiency is approximately

$$\eta_{max} = \frac{\Delta T}{2 \times T_{ave} + \frac{1}{2} \Delta T - \frac{4}{Z}} \tag{28.73}$$

Example 28.9: Thermoelectric generator design

A 12V, 1.5A thermoelectric power generator is needed to power telemetry electronics at a remotely located oil pipeline where the hot, continuously flowing oil produces a 130°C pipe casing temperature. Flowing water (having a temperature of 10°C) also is available at the remote site, and an efficient water-cooled heat sink can maintain the TE generator cold-side at a temperature of +30°C. For a 127-couple, 6 A module, the following values are applicable at $T_{ave} = 353.2K$:

- $S = 0.05544 \text{ V/K}$
- $R = 3.0994 \Omega$
- $K = 0.6632 \text{ W/K}$

Solution

The system parameters are:

- $T_h = +130^\circ\text{C} \approx 403.2K$
- $T_c = +30^\circ\text{C} \approx 303.2K$
- $V_o = 12V$
- $I = 1.5A$

therefore

- $T_{ave} = \frac{1}{2} \times (T_h + T_c) = \frac{1}{2} \times (403.2 + 303.2) = 353.2K$
- $R_L = V_o / I_{te} = 12V / 1.5A = 8.0 \Omega$
- $P_o = V_o \times I_{te} = 12 \times 1.5 = 18 \text{ W}$
- $\Delta T = T_h - T_c = 403.2 - 303.2 = 100K$

It is usually desirable to select a relatively 'high power' thermoelectric module for generator applications in order to minimize the total system cost. Thus a 127 couple, 6A module is used in the design. The required power P_o for the load is $12 \times 1.5 = 18 \text{ W}$. The minimum number of modules needed to meet this load requirement is calculated from the maximum output power from one module, equation (28.60):

$$P_{max} = \frac{(S \times \Delta T)^2}{4 \times R} = \frac{(0.05544 \times 100K)^2}{4 \times 3.0994\Omega} = 2.48W$$

The minimum number of modules needed is:

$$N_{T \min} = \frac{P_o}{P_{\max}} = \frac{18}{2.48} = 7.3, \text{ use } 8$$

Because maximum generator efficiency occurs when $R_{gen} = R_L = 8 \Omega$, it is desirable for most applications to select the series/parallel module configuration that will best approximate this resistance matching. One possible exception to the equalizing R_{gen} with R_L is when a relatively low current (in the mA range) and moderate voltage is required. In this case, the connection of all modules electrically in series may give better results. However, the maximum output voltage from the generator is obtained from a series-connected group of modules only when the resistance of the load is significantly higher than the internal resistance of the generator.

The string series-connected configuration of eight modules gives an internal resistance of:

$$R_{gen} = \frac{N_s}{N_p} \times R = \frac{8}{1} \times 3.0994 \Omega = 24.8 \Omega$$

This 24.8Ω generator resistance is considerably higher than the 8.0Ω load resistance, thereby indicating that a series module connection probably is not the best arrangement. For the all series case where $N_s = 8$ and $N_p = 1$, the open circuit voltage $8 \times 0.05544 \times 100K = 44.35V$ and the loaded output voltage, from equation (28.68), is:

$$V_o = N_s \times S \Delta T \times \frac{R_L}{\frac{N_s}{N_p} \times R + R_L}$$

$$= 8 \times 0.05544 \times 100K \times \frac{8 \Omega}{\frac{8}{1} \times 3.0994 \Omega + 8 \Omega} = 10.82V$$

With a group of eight modules, a logical alternative generator connection configuration is two parallel strings of four series modules, i.e., $N_s = 4$ and $N_p = 2$. Generator resistance for this configuration is thus:

$$R_{gen} = \frac{N_s}{N_p} \times R = \frac{4}{2} \times 3.0994 \Omega = 6.2 \Omega$$

While $R_{gen} = 6.2 \Omega$ does not exactly match the 8.0Ω load resistance, this is the closest resistance match that can be obtained with the selected module type. The voltage for this arrangement is:

$$V_o = N_s \times S \Delta T \times \frac{R_L}{\frac{N_s}{N_p} \times R + R_L}$$

$$= 4 \times 0.05544 \times 100K \times \frac{8 \Omega}{\frac{4}{2} \times 3.0994 \Omega + 8 \Omega} = 12.49V$$

V_o is close to the desired 12V value. If 'fine tuning' of V_o is required, this can be accomplished either by some form of electronic voltage regulation or by externally altering the applied temperature differential ΔT . If the output voltage is significantly out of range despite assessing all possible series/parallel combinations, an alternate thermoelectric module having a different current rating and/or number of couples should be used.

With V_o established, the output power P_o is:

$$P_o = \frac{V_o^2}{R_L} = \frac{12.49^2}{8 \Omega} = 19.51W$$

and the load current is $12.49V/8\Omega = 1.562A$.

The total heat input P_H to the generator, at 1.56A, is:

$$P_H = N_T \times \left(S \times T_h \times \frac{I_{lc}}{N_p} - \frac{1}{2} \times \left(\frac{I_{lc}}{N_p} \right)^2 \times R + K \times \Delta T \right)$$

$$= 8 \times \left(0.05544 \times 403.2K \times \frac{1.562A}{2} - \frac{1}{2} \times \left(\frac{1.562}{2} \right)^2 \times 3.2 \Omega + 0.6632 \times 100K \right) = 662.4W$$

The generator efficiency η is:

$$\eta = \frac{P_o}{P_H} \times 100\% = \frac{19.51W}{662.4W} \times 100\% = 2.95\%$$

The heat transferred to the cold-side heat sink P_c is:

$$P_c = P_H - P_o = 662.4 - 19.5 = 642.9 W$$

The maximum allowable thermal resistance $R_{\theta s}$ of the cold-side heat sink is:

$$R_{\theta s} = \frac{T_{rise}}{P_c} = \frac{30^\circ C - 10^\circ C}{642.9W} = 0.031^\circ C/W$$

For any thermoelectric generator design, it is desirable to maximize the applied temperature differential in order to minimize the total number of modules in the system. This situation can be seen in figure 28.69. Module requirements for a typical 12V, 1A power generator are plotted for several values of T_h based on the use of 127-couple 6A TE modules. From this graph, a large number of modules are needed when the cold side temperature T_c is high and the temperature differential is small. Performance of the cold-side heat sink is import and its thermal resistance must be low. In many cases, cold-side heat sink design will prove to be a challenging engineering problem.

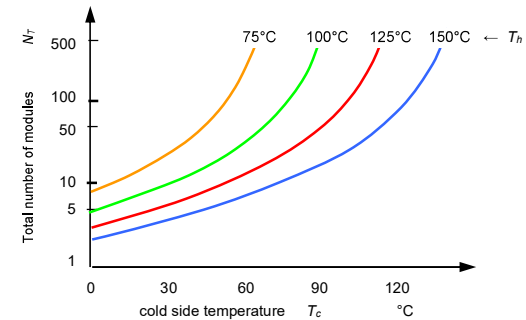

Figure 28.69. The total number of 127-couple, 6A Modules required for a 12V, 1A thermoelectric power generator.

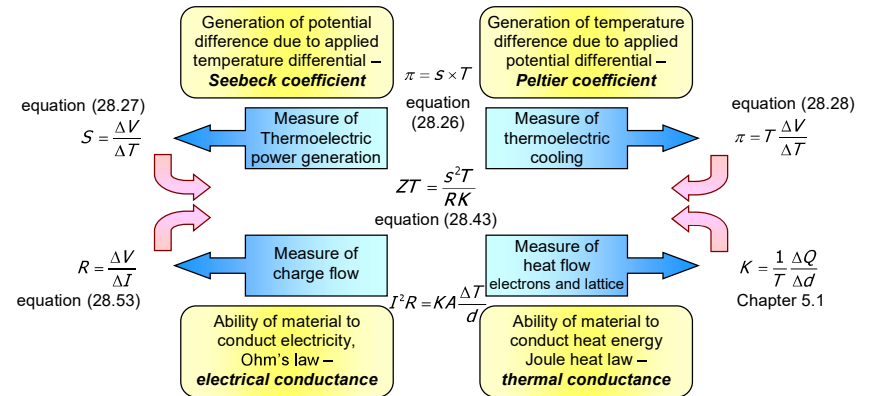

Figure 28.70. Thermoelectric characteristics summary.

28.11.7 Thermoelectric performance

The best room temperature thermoelectric materials are alloys of Bi₂Te₃ with Sb₂Te₃ (giving a *p*-type semiconductor material) and Bi₂Te₃ with Bi₂Se₃ (giving an *n*-type semiconductor material). *ZT* is of the order of 1 at room temperature. This *ZT* value gives a Coefficient of Performance, *CoP*, of about 1, as shown in figure 28.71a, which compared to household refrigerators and air conditioners, with *CoP*'s from 2 to 4), makes thermoelectric cooling generally not competitive. The same holds for power generation, as shown by the low thermoelectric efficiencies in figure 28.71b.

One of the problems with traditional Peltier elements is their limited capability of cooling heat fluxes over 5 to 10W/cm². Because the cooling density of a Peltier cooler is inversely proportional to its length, scaling to smaller size is desirable. The material structure resulting from conventional crystal growth techniques for producing bismuth telluride thermoelectric materials impose significant limitations on thermoelectric element dimensions. Poor manufacturing yields prevent thermoelectric elements from being made short. New fine-grain micro-alloyed bismuth telluride materials that do not suffer element geometry limitations, offer better performance. Nanocoolers use a monolithic process with thicknesses of about 1 to 2 micrometres, have a tunable performance of 10 to 1000W/cm² with a single stage ΔT of 50 to 70K. Thin-film thermoelectrics offer cooling in excess of 160W/cm².

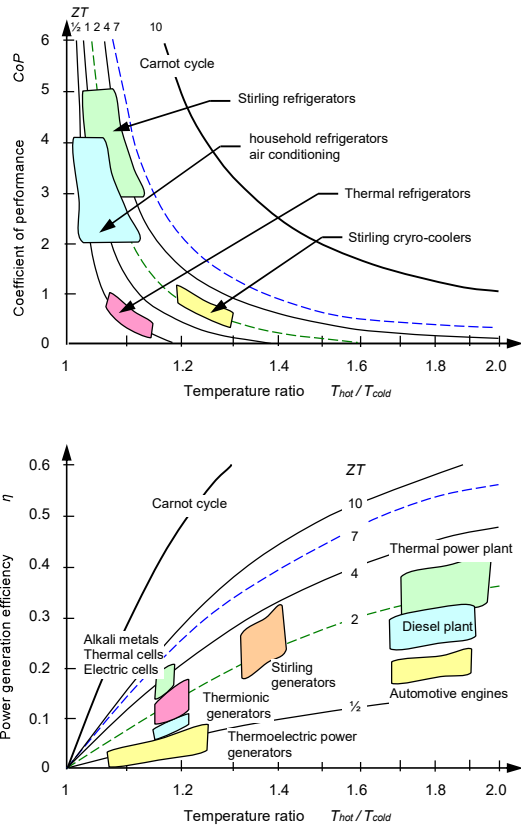
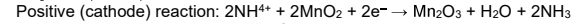
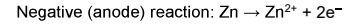

Figure 28.71. Comparison of thermoelectric technology with other energy conversion methods for: (a) cooling and (b) power generation.

28.12 Appendix: Primary cells

Zinc Carbon Battery (1.5V, -10°C to 55°C)

The zinc/carbon cell uses a zinc anode and a manganese dioxide cathode. Carbon is added to the cathode to increase conductivity and retain moisture. The manganese dioxide takes part in the reaction, not the carbon.



The cathode reaction is complicated by the fact that the ammonium ion produces 2 gaseous products:

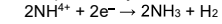

These two products are absorbed by 2 mechanisms in order to prevent pressure build up.:

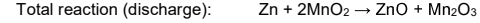
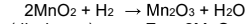
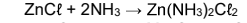

Lithium Manganese Dioxide Battery (3V, -40°C to +125°C)

The coin-type lithium manganese dioxide battery uses manganese dioxide (MnO₂) as its positive active material, lithium (Li) as its negative active material, and an organic electrolyte.

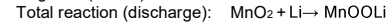
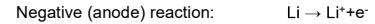

Lithium Thionyl Chloride Battery (3.6V, -55°C to 85°C)

The lithium thionyl chloride battery uses liquid thionyl chloride (SOCl₂) as its positive active material, and lithium (Li) as its negative active material. The reactions of the battery are:

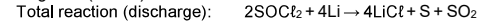
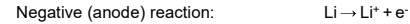
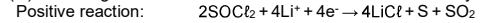

Silver Oxide Battery (1.55V)

The silver oxide battery uses stable monovalent silver oxide (Ag₂O) as its positive (cathode) active material and fine zinc alloy (Zn) as its negative active material. Potassium hydroxide (KOH) – for high load drain or sodium hydroxide (NaOH) – for low load drain, are used as an electrolyte.

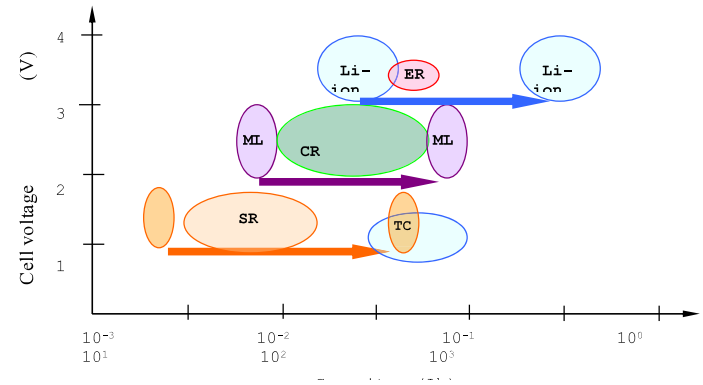
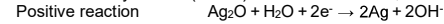
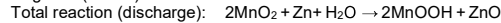
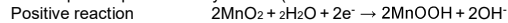

Figure 28.72. Cell capacity versus voltage characteristics.

- | | |
|---------------------------------------|--|
| Primary | Secondary |
| CR- Lithium Manganese Dioxide Battery | Li-ion - Lithium Ion Rechargeable Battery |
| E- Lithium Thionyl Chloride Battery | ML- Lithium Manganese Dioxide Rechargeable Battery |
| SR- Silver Oxide Battery | TC- Titanium Carbon Lithium Rechargeable Battery |

Alkaline Manganese Battery (1.50V)

Electrolytically produced powdered manganese dioxide (MnO₂) is used for the active cathode material, and specially processed fine zinc-alloy powder is used for the active anode material. The electrolyte concentrated aqueous potassium hydroxide (with added zinc oxide to retard anode corrosion) is used.



Zinc Air Battery (1.4V)

The cathode is catalyzed carbon that reduces oxygen from the air, with the anode a gelled mixture of amalgamated zinc powder and a highly conductive solution of KOH in water electrolyte. The electrode reactions for a zinc air battery are as follows:



Table 28.30: Comparison of battery technologies- primary and secondary

Battery Type	Anode	Cathode	Electrolyte	Advantages	Disadvantages	
Primary Batteries	Alkaline Cell	Zn	MnO ₂	KOH	High energy density, long shelf life, good leak resistance, performs well under heavy or light use.	Costlier than zinc-carbon cell but more efficient
	Aluminum/Air Cell	Al	O ₂	KOH or neutral salt solution	Can operate exposed to sea water (neutral salt solution), easily replaceable electrolytes/electrodes	Anode quickly degrades, short shelf life, short operational life
	Ledacché Cell (Zinc Carbon or Dry Cell)	Zn	MnO ₂	NH ₄ Cl or ZnCl ₂	Cheap and common (oldest available battery type)	Poor performance under heavy or continuous use.
	Lithium Cell	Li	Various liquid or solid materials	SOCl ₂ , SO ₂ Cl ₂ , or organic solutions	Very high energy density, long shelf life, long operational life	Poor performance under heavy use, vulnerable to leaks or explosions
	Mercury Oxide Cell	Zn or Cd	HgO	KOH	Higher energy density than (Zn/MnO ₂) alkaline cell	High cost and being phased out due to toxicity concerns
	Zinc/Air Cell	Zn	O ₂	KOH	Environmentally benign, cheap, very high energy density, and virtually unlimited shelf life	Short operational life, low power density
Secondary (rechargeable) Batteries	Iron Nickel Cell	Fe	Ni(OH) ₂	KOH	Long life under a variety of conditions, excellent back-up battery	Low rate-performance, slow recharge rate
	Lead/Acid Cell	Pb	PbO ₂	dilute H ₂ SO _{4(aq)}	Low cost, long life cycle, operates well under a variety of conditions. Common car batteries	Minor risk of leakage
	Lithium Ion Cell	C, carbon compounds	Li ₂ O, intercalated into graphite	LiPF ₆ , LiBF ₄ , related compounds	Relatively cheap, high energy density, long shelf life, long operational life, long cycle life	Minor risk of leakage
	Nickel/Cadmium Cell	Cd	Ni(OH) ₂	KOH	Good performance under heavy discharge and/or low temperature	High cost, can temporarily lose cell capacity if not fully discharged before recharging (memory effect)
	Nickel/Metal Hydride (NiMH) Cell	Lanthanide or Ni alloys	Ni(OH) ₂	KOH	High capacity and power density	High cost, some memory effect
	Nickel/Zinc Cell	Zn	NiO	KOH	Low cost, low toxicity, good for high discharge rates	Zinc on the electrolyte tends to redeposit unevenly on anode, severely reducing efficiency
	Sodium/Sulfur Cell	Molten Na	Molten S	Al ₂ O ₃	Inexpensive materials, long cycle life, high energy and power	High operational temperature lower efficiency, some danger of explosion upon degradation

Table 28.31: Comparison of three battery technologies

Items	Li-ion	Ni-MH	Lead-acid
Working voltage (V)	3.7	1.2	2.0
Gravimetric energy density (Wh/kg)	130~200	60~90	30~40
Volumetric energy density (Wh/L)	340~400	200~250	130~180
Cycle life (cycles)	500	400	300
Capacity self discharge rate (% per month)	5%	30%	10%
Memory effect	None	40%	None
Energy efficiency (C _{discharge} /C _{charge})	99%	70%	75%
Weight comparison for the same capacity	1	2	4
Size comparison for the same capacity	1	1.8	3.5
Reliability	High	Low	High

28.13 Appendix: Empirical battery model

The electrochemical battery can be modelled as a series resistor and a charge-dependent voltage source whose voltage as a function of charge has the following reciprocal relationship:

$$V = V_o \left[1 - \frac{\alpha(1-x)}{1-\beta(1-x)} \right]$$

where: x is the ratio of the ampere-hours left to the battery rated ampere-hours, AH .

V_o is the voltage when the battery is fully charged, as defined by the nominal voltage, $V_{nominal}$ parameter.

The constants α and β are calculated to satisfy the following battery conditions:

- the battery voltage is zero when the charge is zero, that is, when $x = 0$.
- the battery voltage is V_1 (the voltage $V_1 < V_{nominal}$ when charge is AH_1 parameter value) when the charge is AH_1 when the no-load volts are V_1 , that is, when $x = AH_1/AH$.

The equation defines a reciprocal relationship between internal voltage and remaining charge. It is an approximation to a real battery, but it does replicate the increasing rate of voltage drop at low charge levels. It also ensures that the battery voltage becomes zero when the charge level is zero.

$V_{nominal}$ is the nominal voltage; the open circuit voltage at the output terminals when the battery is fully charged, typically 12 V. Ampere-Hour rating, AH , is the maximum battery charge in ampere-hours, typically 50 hr*A. Initial charge: the battery charge at the start, typically 50 hr*A.

R_{int} is the internal resistance, typically less than 1Ω.

Battery charge capacity models the charge capacity of the battery according to the battery voltage which decreases as charge decreases.

Voltage $V_1 < V_{nominal}$ when charge is AH_1 . The battery no-load output voltage, typically 11.5 V, when the charge level is AH_1 , typically 25 hr*A.

Self-discharge resistance of the battery, R_2 : the resistance across the battery output terminals in the model that represents battery self-discharge, typically 2kΩ.

The state of charge SoC measures the fraction of charge remaining in the battery, and is defined as

$$SoC = 100 \left(1 - \frac{Q}{C} \right) = 100 \left(1 - \frac{\int_0^t idt}{C} \right) \quad 0 \leq SoC \leq 1$$

where C is the battery capacity in Ah and Q is the charge already delivered in Ah.

A fully charged battery has a SoC of 100%, while a fully discharged battery has a SoC of 0%. Depth of discharge DoD measures the fraction of discharge reached, and is

$$DoD = 1 - SoC$$

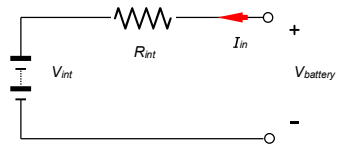
Figure 28.73. *Battery model.***Reading list**

<http://www.mpoweruk.com/>

<http://americanhistory.si.edu/fuelcells/index.htm>

<http://www1.eere.energy.gov>

http://www.fctec.com/fctec_basics.asp

blank