

CHAPTER 25

FACTS Devices and Custom Controllers

FACTS is the acronym for Flexible AC Transmission Systems, where power electronic apparatus is incorporated into ac electrical networks to efficiently improve static and dynamic transmission capacity.

Originally electrical power generation, transmission, and distribution systems were direct current. The advent of the three-phase induction motor and the ability of transformers to convert one ac voltage to another ac voltage level (at the same frequency), saw the unassailable rise to dominance of ac electrical power systems. But for long distance electrical power transmission, a dc transmission system is a viable possibility. One of the highest functional dc voltages for dc transmission, HVDC, is $\pm 600\text{kV}$ over 785km and 805km transmission lines in Brazil. Each of the two bipolar dc transmission systems carry 3.15GW. Also involved are three, three-phase 765kV ac lines which are 1GVAR variable capacitor series compensated (FACTS) at two intermediate substations.

A traditional electric power system is interconnected generating units and load centres via high-voltage electric transmission lines. The system comprises generation, transmission, and distribution subsystems, which usually belonged to the same electric utility in a given area. But the electric power industry has deregulated from large, vertically integrated utilities providing power at regulated rates to an industry that incorporates competitive companies selling unbundled power at potentially lower rates. With this new structure, which includes separate generation, distribution, and transmission companies with an open-access policy, comes the need for tighter system control strategies. The strategies must maintain the reliability level that consumers benefit from and expect, even with the extensive structural changes, such as a loss of a large generating unit or a transmission line, and loading conditions, such as the continuous varying power consumption. Electricity deregulation affects all aspects of the electrical power industry, from generation, to transmission, distribution, and consumption. Transmission circuits, in particular, operate close to their thermal limits because existing transmission lines are loaded near to their stability limits and construction of new transmission circuits is hindered by environmental and political aspects. New equipment and control devices have emerged to control the power flow on transmission lines and to enhance system stability and reliability. Flexible AC transmission systems (FACTS) and FACTS controllers, which are power electronics devices used to control power flow and enhance stability, are replacing mechanical control devices. FACTS play a key role in the operation and control of electrical power systems.

25.1 Flexible AC Transmission Systems - FACTS

FACTS employ power electronics switching devices and circuits to improve and control power flow in ac transmission and distribution systems. The purpose of a FACTS controller is to continuously and rapidly:

- facilitate regulation of the supply voltage to within a specified range;
- allow the transmission line to carry more power, closer to its thermal limit; and
- improve ac system stability, reliability, availability, and security.

In essence, FACTS compensate transmission line reactance (VAR compensation) to yield unity power factor, hence maximum power for a given voltage rating and thermal limit, I^2R . FACTS also increase transmission power by minimising current harmonics, hence associated harmonic I^2R losses, thereby maximising the fundamental current. Additionally, with appropriate control, FACTS devices can actively damp system oscillations, improving network stability margins, thereby allowing increased use of the transmission infrastructure. FACTS can enhance the through-put and capacity of present, new, and upgraded power transmission lines.

25.2 Power quality

Non-linear and discontinuous loads decrease power quality.

Other than the steady-state voltage magnitude and frequency, power quality is degraded by:

- Voltage sagging – temporarily, a low voltage distribution system user fault interacts with the rest of the network, with an effect that decreases as the distance from the disturbance increases.
- Grounding – user caused common problem due to earth loops, improper connection, and high impedance connection to ground.
- Harmonics – user created due to non-linear loads creating harmonic currents which cause harmonic power losses and harmonic voltage drops across the system impedance.
- Voltage fluctuation and flickering – caused by high power, low frequency (<50Hz) equipment.
- Transients and voltage swelling – in the voltage supply due to load switching at the supply frequency and its harmonics.

These supply problems can be mitigated by a combination of techniques including:

- Passive and active harmonic filters;
- Static and adaptive VAr compensators; and
- Uninterruptible power supplies.

25.3 Principles of power transmission

The phasor diagram for one phase of a balanced three-phase transmission system of figure 25.1a is shown in figure 25.1b, where it is assumed the load has a lagging power factor angle ϕ . The ac line is represented by its lumped series impedance (Thevenin's short circuit impedance) $Z_L = R_L + jX_L$. The apparent (complex) power leaving the sending end bus and flowing to the terminal (or receiving) bus is

$$S_s = P_s + jQ_s = \mathbf{V}_s \mathbf{I}_L^* = V_s I \cos \phi + jV_s I \sin \phi$$

$$\text{where } I_L = I = I_p + jI_Q = \frac{\mathbf{V}_s - \mathbf{V}_T}{Z_L} = (\mathbf{V}_s - \mathbf{V}_T) Y_L = (\mathbf{V}_s - \mathbf{V}_T)(G_L + jB_L) \quad (25.1)$$

$$\text{where } Z_L = \frac{1}{Y_L} = R_L + jX_L \text{ and } G_L = \frac{R_L}{R_L^2 + X_L^2} \quad B_L = -\frac{X_L}{R_L^2 + X_L^2}$$

$$S_s^* = P_s - jQ_s = \mathbf{V}_s^* \mathbf{I}_L = \mathbf{V}_s^* \frac{(\mathbf{V}_s - \mathbf{V}_T)}{Z} = \frac{\mathbf{V}_s^2 - \mathbf{V}_s^* \mathbf{V}_T}{Z} = (\mathbf{V}_s^2 - \mathbf{V}_s^* \mathbf{V}_T)(G_L + jB_L) \quad (25.2)$$

$$\text{where } \mathbf{V}_s^* \mathbf{V}_T = V_s V_T (\cos \delta - j \sin \delta)$$

The sending real and reactive components are

$$P_s = V_s \frac{(V_s - V_T \cos \delta) R_L}{Z_L^2} + V_s V_T \frac{X_L}{Z_L^2} \sin \delta = V_s (V_s - V_T \cos \delta) G_L - V_s V_T B_L \sin \delta$$

$$Q_s = V_s \frac{V_s X_L - V_T R_L \sin \delta}{Z_L^2} - V_s V_T \frac{X_L}{Z_L^2} \cos \delta = -V_s^2 B_L - V_s V_T G_L \sin \delta + V_s V_T G_L \cos \delta \quad (25.3)$$

where $Z_L^2 = R_L^2 + X_L^2$ and $\delta = \delta_s - \delta_T$ is the power angle.

The real and reactive components received at the terminal bus are

$$P_T = V_T \frac{(-V_T + V_s \cos \delta) R_L}{Z_L^2} + V_s V_T \frac{X_L}{Z_L^2} \sin \delta = V_T (-V_T + V_s \cos \delta) G_L - V_s V_T B_L \sin \delta$$

$$Q_T = V_T \frac{-V_T X_L - V_s R_L \sin \delta}{Z_L^2} + V_s V_T \frac{X_L}{Z_L^2} \cos \delta = V_T (V_T B_L - V_s G_L \sin \delta) - V_s V_T B_L \cos \delta \quad (25.4)$$

The real and reactive line 'losses' are the difference between the power sent and the power received:

$$P_L = P_s - P_T = \frac{(V_s^2 + V_T^2) R_L}{Z_L^2} - 2V_s V_T \frac{R_L}{Z_L^2} \cos \delta = (V_s^2 + V_T^2) G_L - 2V_s V_T G_L \cos \delta$$

$$Q_L = Q_s - Q_T = \frac{(V_s^2 + V_T^2) X_L}{Z_L^2} - 2V_s V_T \frac{X_L}{Z_L^2} \cos \delta = -(V_s^2 + V_T^2) B_L + 2V_s V_T B_L \cos \delta \quad (25.5)$$

Since the resistive voltage drop is usually much smaller than the reactive voltage, R_L is neglected (that is R/X is small). Possible model shunt components are also neglected. The transmission line voltage drop, which is the reactive voltage $jX_L I$, leads the current phasor I by 90° . The angle between the sending voltage V_s , δ_s , and the terminal (or receiving) voltage V_T , δ_T , is the transmission load angle, δ .

The power flow equation, with $R_L = 0$, becomes

$$P_S = P_T = P = \frac{V_S V_T}{X_L} \sin \delta \tag{25.6}$$

and the reactive power, with $R_L = 0$, for the terminal and sending ends are

$$Q_T = V_T \frac{V_S \cos \delta - V_T}{X_L} \tag{25.7}$$

$$Q_S = V_S \times \frac{V_S - V_T \cos \delta}{X_L} \tag{25.8}$$

The average reactive power flow is

$$Q_{ST} = \frac{1}{2}(Q_S + Q_T) = \frac{1}{2} \frac{V_S^2 - V_T^2}{X_L} \tag{25.9}$$

While the line inductance absorbed reactive power is $Q_{XL} = Q_S - Q_T = I^2 X_L = V_L^2 / X_L$.

The transmission line midpoint voltage (for compensation) is given by

$$V_M = \frac{1}{2}(V_T + V_S) \quad \angle \frac{1}{2}\delta \tag{25.10}$$

Reactive and real power dependence on load angle is shown in figure 25.1c, where from equation (25.6) maximum power of $P = V_S V_T / X_L$ occurs at $\delta = 90^\circ$. Maximum VA (generating) of $Q_S = V_S \times (V_S + V_T) / X_L$ occurs at the sending end for $\delta = 180^\circ$, with a maximum (absorbing) at the terminal end, where $|Q_T|_{\max} = V_T \times (V_S + V_T) / X_L$.

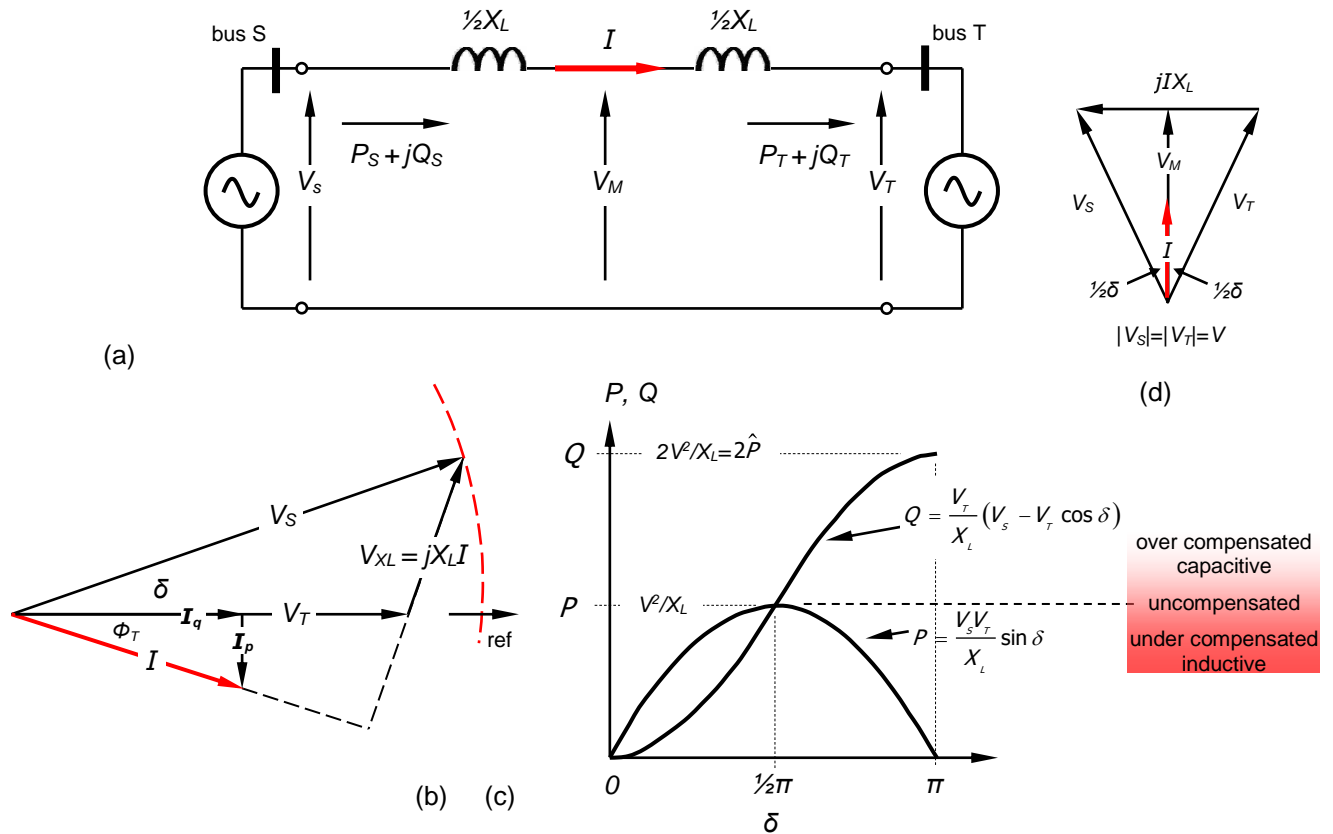

Figure 25.1. Basic HVAC transmission system: (a) circuit diagram; (b) phasor diagram; (c) power and VAR versus load angle δ (maximum when $|V_S| = |V_T|$); and (d) phasor diagram for $|V_S| = |V_T|$.

For simplicity, if $|V_S| = |V_T| = V$, then, using the midpoint voltage V_M as reference (see figure 25.1d), equations (25.6) to (25.10) simplify to

$$\begin{aligned} \mathbf{I} &= \frac{\mathbf{V}_S - \mathbf{V}_T}{X_L} = \frac{2V}{X_L} \sin \frac{1}{2}\delta \quad \angle \frac{1}{2}\pi & \mathbf{V}_M &= \frac{\mathbf{V}_S + \mathbf{V}_T}{2} = V \cos \frac{1}{2}\delta \quad \angle 0 \\ P_T &= |\mathbf{V}_M| |\mathbf{I}| = \frac{V^2}{X_L} \sin \delta & Q &= Q_S = -Q_T = V |\mathbf{I}| \sin \frac{1}{2}\delta = \frac{V^2}{X_L} (1 - \cos \delta) \end{aligned} \tag{25.11}$$

As shown in figure 25.1c, the maximum active power is $P = V^2 / X_L$ at $\delta = 90^\circ$ whilst the maximum reactive power is $Q = 2V^2 / X_L$, at $\delta = 180^\circ$.

Equation (25.6) can be used to specify how power and line current flow can be controlled (increased).

- Increase the voltage magnitudes at either or both ends, with voltage support or applying a shunt voltage V_M at the midpoint,
- Reduce the line reactance X_S , by (series) line compensation
- Increase the power load angle, by inserting series variable voltage to give a phase shift

The power flow can be reversed by changing the sign of the power angle; that is, a positive power angle $\delta > 0$ corresponds to a power flow from the sending end to the receiving bus, whereas a negative power angle $\delta_R > \delta_S$ corresponds to a power flow from the receiving to the sending bus.

Similarly, from equation (25.9), both voltage magnitudes and line reactance affect the reactive power. If both voltage magnitudes are the same, that is, a flat voltage profile, each bus will send half of the reactive power absorbed by the line. The power flow is in a sending to receiving direction when $V_R < V_S$. Hence, the four parameters that affect real and reactive power flows are V_S , V_R , X_L , and δ . At the receiving end T, equations (25.6) and (25.8) can be combined:

$$P^2(\delta) + \left(Q_T(\delta) + \frac{V_T^2}{X_L} \right)^2 = \left(\frac{V_S V_T}{X_L} \right)^2 \quad (25.12)$$

This equation represents a circle, centred $(0, -V_T^2 / X_L)$, radius $V_S V_T / X_L$. It relates real and reactive powers received at bus T to the four parameters: V_S , V_T , δ , X_L .

Similarly, the relationship between the real and reactive powers sent to the line from the sending bus S can be expressed as

$$P^2(\delta) + \left(Q_S(\delta) - \frac{V_S^2}{X_L} \right)^2 = \left(\frac{V_S V_T}{X_L} \right)^2 \quad (25.13)$$

Equations (25.7) and (25.8) show that any change in active power, changes the reactive power requirements of both the sending and terminal ends.

Example 25.1: AC transmission line VAR

If the line reactance of $X_L = 0.05$ pu in conjunction with operating conditions result in a terminal voltage which is 5% less than the sending end, for 1 pu power flow calculate:

- The load angle δ
- The sending and terminal end reactive power requirements, Q_S , Q_T
- The line current, hence the line reactive power, Q_{XL}
- The midpoint shunt voltage that can be inserted that does not change operating conditions

Solution

- i. From equation (25.6) rearranged, the load angle is

$$\sin \delta = P_T \times \frac{X_L}{V_S V_T} = 1.0 \times \frac{0.05}{1.0 \times 0.95} = 0.0526$$

That is $\delta = 3.0^\circ$ and $\cos \delta = 0.9986$.

- ii. From equation (25.8), the sending end VAR is

$$\begin{aligned} Q_S &= V_S \times \frac{V_S - V_T \cos \delta}{X_L} \\ &= 1.0 \times \frac{1.0 - 0.95 \times 0.9986}{0.05} = 1.026 \text{ pu} \end{aligned}$$

Since Q_S is positive, the sending end is generating VAR's, that is, the power factor is lagging at the sending end (I is lagging V_S).

The terminal end VAR is given by equation (25.7)

$$Q_T = V_T \frac{V_S \cos \delta - V_T}{X_L}$$

$$= 0.95 \times \frac{1.0 \times 0.9986 - 0.95}{0.05} = 0.923 \text{ pu}$$

Since Q_T is positive, the terminal end is absorbing VAR's, that is, the power factor is lagging at the terminal end (I is lagging V_T).

iii. The current can be evaluated by equating equation (25.1) with equations (25.6) and (25.7)

$$I = I \cos \phi + jI \sin \phi = I \times e^{j\phi}$$

$$I \sin \phi = \frac{V_S \cos \delta - V_T}{X_L} \qquad I \cos \phi = \frac{V_S \sin \delta}{X_L}$$

$$= \frac{1.0 \times 0.9986 - 0.95}{0.05} \qquad = \frac{1.0 \times 0.0526}{0.05}$$

$$= 0.972 \text{ pu} \qquad = 1.0526 \text{ pu}$$

$$I = 0.972 + j1.0526 \text{ pu} = 1.433^{j42.3^\circ} \text{ pu wrt } V_T$$

The line reactive power is given by $Q_S - Q_T = 1.026 - 0.923 = 0.103 \text{ pu}$. Alternatively, the line reactive power can be calculated from $I^2 X_L = 1.433^2 \times 0.050 = 0.103 \text{ pu}$.

iv. The midpoint voltage is given by equation (25.10)

$$V_M = \frac{1}{2}(V_T + V_S) \quad \angle \frac{1}{2}\delta$$

$$= \frac{1}{2}(0.95 + 1.0) = 0.975 \text{ pu} \quad \angle 1.5^\circ \text{ wrt } V_S$$

If a voltage source with this magnitude and angle, with respect to the sending end, is shunt connected at the midpoint, then no current flows, hence no active or reactive power change occurs.

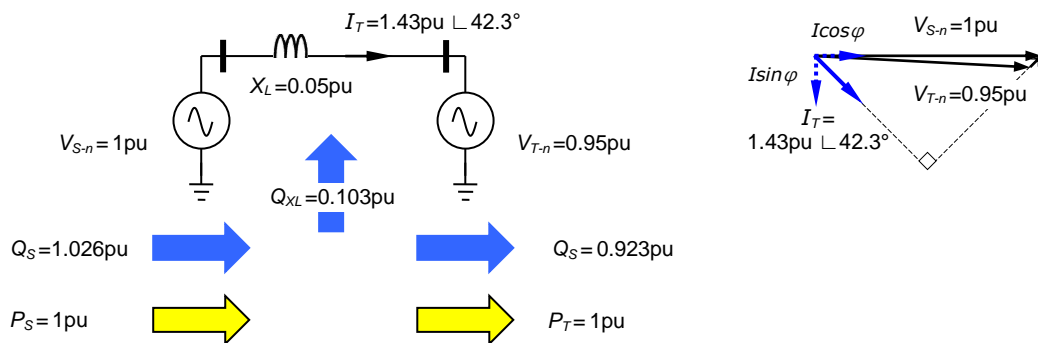

Figure 25.2. Example 25.1.



25.4 The theory of instantaneous power ($p-q$) in three-phase

Using Clarke's transformation, $p-q$ theory changes a stationary reference frame three-phase four-wire system into instantaneous variables into stationary reference frame orthogonal α - β -0 axis based coordinates. The system voltages (and currents) of a four-wire system (interconnected source and load neutrals of a three-phase three-wire system) are related according to

$$\begin{bmatrix} e_0 \\ e_\alpha \\ e_\beta \end{bmatrix} = \sqrt{\frac{2}{3}} \begin{bmatrix} \frac{1}{\sqrt{2}} & \frac{1}{\sqrt{2}} & \frac{1}{\sqrt{2}} \\ 1 & -\frac{1}{2} & -\frac{1}{2} \\ 0 & \frac{1}{2}\sqrt{3} & -\frac{1}{2}\sqrt{3} \end{bmatrix} \begin{bmatrix} e_a \\ e_b \\ e_c \end{bmatrix} \qquad \begin{bmatrix} i_0 \\ i_\alpha \\ i_\beta \end{bmatrix} = \sqrt{\frac{2}{3}} \begin{bmatrix} \frac{1}{\sqrt{2}} & \frac{1}{\sqrt{2}} & \frac{1}{\sqrt{2}} \\ 1 & -\frac{1}{2} & -\frac{1}{2} \\ 0 & \frac{1}{2}\sqrt{3} & -\frac{1}{2}\sqrt{3} \end{bmatrix} \begin{bmatrix} i_a \\ i_b \\ i_c \end{bmatrix} \quad (25.14)$$

or the inverse Clarke's transformation, the voltage case, is

$$\begin{bmatrix} e_a \\ e_b \\ e_c \end{bmatrix} = \sqrt{\frac{2}{3}} \begin{bmatrix} \frac{1}{\sqrt{2}} & 1 & 0 \\ \frac{1}{\sqrt{2}} & -\frac{1}{2} & \frac{1}{2}\sqrt{3} \\ \frac{1}{\sqrt{2}} & -\frac{1}{2} & -\frac{1}{2}\sqrt{3} \end{bmatrix} \begin{bmatrix} e_0 \\ e_\alpha \\ e_\beta \end{bmatrix} \quad (25.15)$$

The corresponding current transformations are obtained by replacing current for voltage.

Figure 25.3 shows a three-phase three-wire system in the a - b - c coordinates, $i_o = 0$, where no zero-sequence voltage need be included in the three-phase three-wire system ($e_a + e_b + e_c = 0$ and $i_a + i_b + i_c = 0$). That is, $e_o = 0$ such that instantaneous zero sequence power ($p_o + p_o$) $p_o = i_o \times e_o = 0$. Three-phase voltages and currents in a - b - c coordinates, shown in figure 25.3, can be transformed into the two-phase voltages and currents in α - β coordinates, assuming the a and α axes coincide ($\theta_{a\alpha} = 0$), as follows:

$$\begin{bmatrix} e_\alpha \\ e_\beta \end{bmatrix} = \sqrt{\frac{2}{3}} \begin{bmatrix} 1 & -1/2 & -1/2 \\ 0 & 1/2\sqrt{3} & -1/2\sqrt{3} \end{bmatrix} \begin{bmatrix} e_a \\ e_b \\ e_c \end{bmatrix} \quad (25.16)$$

$$\begin{bmatrix} i_\alpha \\ i_\beta \end{bmatrix} = \sqrt{\frac{2}{3}} \begin{bmatrix} 1 & -1/2 & -1/2 \\ 0 & 1/2\sqrt{3} & -1/2\sqrt{3} \end{bmatrix} \begin{bmatrix} i_a \\ i_b \\ i_c \end{bmatrix} \quad (25.17)$$

The instantaneous voltage and current vectors are defined as

$$e = e_\alpha + j e_\beta = \sqrt{e_\alpha^2 + e_\beta^2} \angle \tan^{-1} \frac{e_\beta}{e_\alpha}$$

$$i = i_\alpha + j i_\beta = \sqrt{i_\alpha^2 + i_\beta^2} \angle \tan^{-1} \frac{i_\beta}{i_\alpha}$$

The instantaneous reactive, complex or apparent power, s , either in a - b - c coordinates or in α - β coordinates is defined by

$$s = e i^* = (e_\alpha + j e_\beta)(i_\alpha - j i_\beta) = (e_\alpha i_\alpha + e_\beta i_\beta) + j(e_\beta i_\alpha - e_\alpha i_\beta) = p + j q$$

The instantaneous real power, p , either in a - b - c coordinates or in α - β coordinates is defined by

$$p = p_a + p_b + p_c = e_a i_a + e_b i_b + e_c i_c = e_\alpha i_\alpha + e_\beta i_\beta = \frac{dW}{dt} \quad (25.18)$$

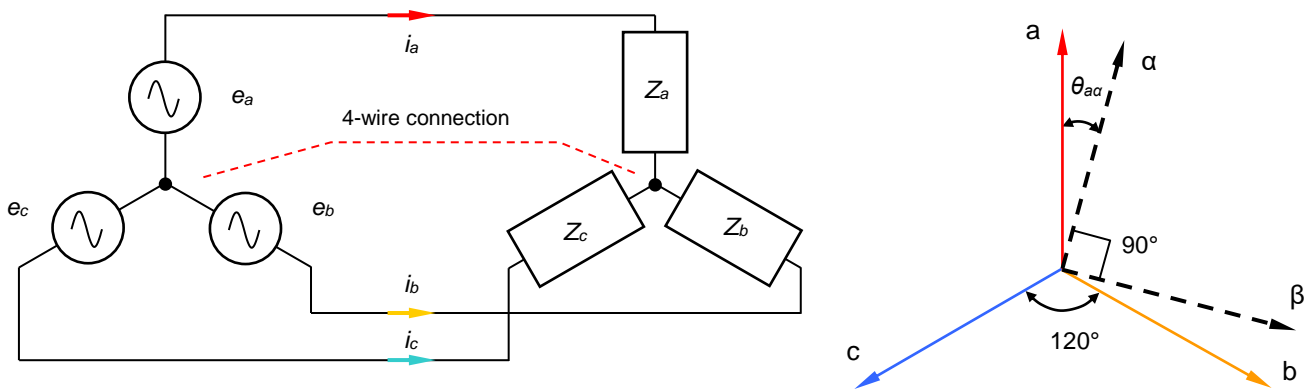

Figure 25.3. Phase voltages and line currents in a three-phase three-wire system and transformation of a - b - c coordinates into α - β - 0 coordinates.

The three-phase instantaneous imaginary (reactive) power, q , is defined by

$$q = e_\alpha i_\beta - e_\beta i_\alpha = \frac{1}{\sqrt{3}} (i_a (v_c - v_b) + i_b (v_a - v_c) + i_c (v_b - v_a)) \quad (25.19)$$

In matrix form, the two powers are:

$$\begin{bmatrix} p \\ q \end{bmatrix} = \begin{bmatrix} e_\alpha & e_\beta \\ -e_\beta & e_\alpha \end{bmatrix} \begin{bmatrix} i_\alpha \\ i_\beta \end{bmatrix} \quad (25.20)$$

$e_\alpha \cdot i_\alpha$ and $e_\beta \cdot i_\beta$ are the instantaneous real powers in the α -phase and the β -phase because both are defined as the product of the in-phase instantaneous voltage in one phase and the instantaneous current in the same phase. $e_\alpha \cdot i_\beta$ and $e_\beta \cdot i_\alpha$ are the instantaneous reactive powers because defined by the product of the instantaneous voltage in one phase and the instantaneous current in the other phase, which is at quadrature.

Since e_α and e_β are at quadrature, the determinant of the voltage matrix in equation (25.20) is non-zero, hence the inverse of equation (25.20) always exists (and represents the necessary three-phase three-wire, nonlinear shunt compensating current):

$$\begin{bmatrix} i_\alpha \\ i_\beta \end{bmatrix} = \begin{bmatrix} e_\alpha & e_\beta \\ -e_\beta & e_\alpha \end{bmatrix}^{-1} \begin{bmatrix} p \\ q \end{bmatrix} = \frac{1}{e_\alpha^2 + e_\beta^2} \begin{bmatrix} e_\alpha & -e_\beta \\ e_\beta & e_\alpha \end{bmatrix} \begin{bmatrix} p \\ q \end{bmatrix} \quad (25.21)$$

The instantaneous currents in α - β coordinates, i_α and i_β , can be separated into two instantaneous current components:

$$\begin{aligned} \begin{bmatrix} i_\alpha \\ i_\beta \end{bmatrix} &= \begin{bmatrix} e_\alpha & e_\beta \\ -e_\beta & e_\alpha \end{bmatrix}^{-1} \begin{bmatrix} p \\ 0 \end{bmatrix} + \begin{bmatrix} e_\alpha & e_\beta \\ -e_\beta & e_\alpha \end{bmatrix}^{-1} \begin{bmatrix} 0 \\ q \end{bmatrix} \\ &\equiv \begin{bmatrix} i_{\alpha p} \\ i_{\beta p} \end{bmatrix} + \begin{bmatrix} i_{\alpha q} \\ i_{\beta q} \end{bmatrix} \end{aligned} \quad (25.22)$$

The inverse Clarke transformation of equation (25.22) gives the currents in the abc axes.

Let the instantaneous powers in the α -phase and the β -phase be p_α and p_β , respectively, and are given by the conventional definition:

$$\begin{bmatrix} p_\alpha \\ p_\beta \end{bmatrix} = \begin{bmatrix} e_\alpha i_\alpha \\ e_\beta i_\beta \end{bmatrix} = \begin{bmatrix} e_\alpha i_{\alpha p} \\ e_\beta i_{\beta p} \end{bmatrix} + \begin{bmatrix} e_\alpha i_{\alpha q} \\ e_\beta i_{\beta q} \end{bmatrix} \quad (25.23)$$

From equations (25.22) and (25.23), the three-phase instantaneous real power, p , is:

$$\begin{aligned} p &= p_\alpha + p_\beta = e_\alpha i_{\alpha p} + e_\beta i_{\beta p} + e_\alpha i_{\alpha q} + e_\beta i_{\beta q} \\ &= \frac{e_\alpha^2}{e_\alpha^2 + e_\beta^2} p + \frac{e_\beta^2}{e_\alpha^2 + e_\beta^2} p + \frac{-e_\alpha e_\beta}{e_\alpha^2 + e_\beta^2} q + \frac{e_\alpha e_\beta}{e_\alpha^2 + e_\beta^2} q \\ &= p_{\alpha p} + p_{\beta p} + p_{\alpha q} + p_{\beta q} \end{aligned} \quad (25.24)$$

where

$i_{\alpha p}$, $p_{\alpha p}$ are the instantaneous active current and active power on the α axis,
 $i_{\beta p}$, $p_{\beta p}$ are the instantaneous active current and active power on the β axis,
 $i_{\alpha q}$, $p_{\alpha q}$ are the instantaneous reactive current and reactive power on the α axis,
 $i_{\beta q}$, $p_{\beta q}$ are the instantaneous reactive current and reactive power on the β axis,

The sum of the third and fourth terms on the right-hand side in equation (25.24) is always zero. From equations (25.23) and (25.24):

$$p = e_\alpha i_{\alpha p} + e_\beta i_{\beta p} \equiv p_{\alpha p} + p_{\beta p} \quad (25.25)$$

$$0 = e_\alpha i_{\alpha q} + e_\beta i_{\beta q} \equiv p_{\alpha q} + p_{\beta q} \quad (25.26)$$

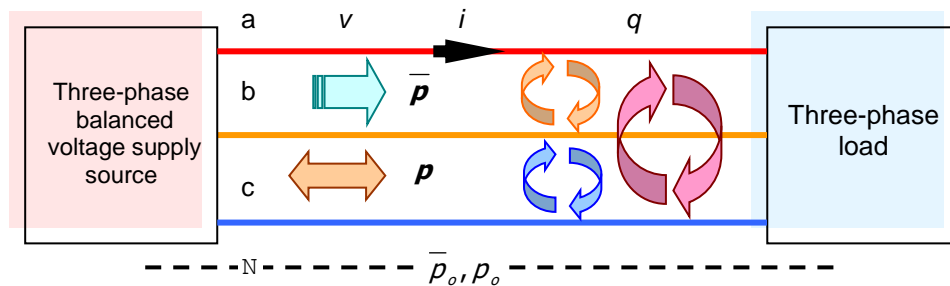

Figure 25.4. Graphical representation of the three phase power components decomposed into p - q power components.

Equations (25.25) and (25.26) imply the following conclusions:

- The sum of the power components, $p_{\alpha p}$ and $p_{\beta p}$, is the three-phase instantaneous real power, p , given by equation (25.18). Therefore, $p_{\alpha p}$ and $p_{\beta p}$ are referred to as the α -phase and β -phase instantaneous active powers.
- The other power components, $p_{\alpha q}$ and $p_{\beta q}$, cancel, making no contribution to the instantaneous power flow from the source to the load. Therefore, $p_{\alpha q}$ and $p_{\beta q}$ are referred to as the α -phase and β -phase instantaneous reactive powers.
- Thus, for example, in the case of a shunt active filter without energy storage, instantaneous compensation of the current components, $i_{\alpha q}$ and $i_{\beta q}$ or the power components, $p_{\alpha q}$ and $p_{\beta q}$ can be achieved. The theory based on equation (25.20) reveals the components that can be eliminated from the α -phase and β -phase instantaneous currents, i_α and i_β or the α -phase and β -phase instantaneous real powers, p_α and p_β .

When the load is non-linear and unbalanced the real and imaginary powers can be split into average and alternating components, as follows:

$$p = \bar{p} + \tilde{p} = \bar{p} + \tilde{p}_h + \tilde{p}_{2f1}$$

and

$$q = \bar{q} + \tilde{q} = \bar{q} + \tilde{q}_h + \tilde{q}_{2f1}$$

where \bar{p} and \bar{q} are average components

p_h and q_h are alternating components, corresponding to no net energy to the load

h harmonic

p_{2f1} and q_{2f1} alternating components with $2f1$ being twice the fundamental frequency

The corresponding three phase currents, associated with the average and alternating power components, decompose into

$$i = i_{\bar{p}} + i_{\tilde{q}} + i_h + i_{2f1}$$

From these power components, the current components in $a-b-c$ coordinates can be calculated from equation (25.21).

In a three-phase four-wire system, the shunt compensating current is:

$$\begin{bmatrix} i_{c0} \\ i_{c\alpha} \\ i_{c\beta} \end{bmatrix} = \frac{1}{(e_\alpha^2 + e_\beta^2)e_0} \begin{bmatrix} 0 & 0 & e_\alpha^2 + e_\beta^2 \\ e_0 e_\alpha & -e_0 e_\beta & 0 \\ e_0 e_\beta & e_0 e_\alpha & 0 \end{bmatrix} \begin{bmatrix} p_0 \\ \tilde{p} \\ q \end{bmatrix}$$

SHUNT Compensators	characteristics	SERIES Compensators	characteristics
 <p>Midpoint shunt capacitance</p>	<p>$I_{s/c}$ almost unchanged</p> <p>δ slightly increased</p> <p>V_{PCC} increased</p> <p>Heavy load voltage stabilisation</p> $B_c = \frac{VAR_{demand} - VAR_{uncomp}}{V^2}$ <p>$C = B_c / \omega$</p>	 <p>Midpoint series capacitance</p>	<p>$I_{s/c}$ increased</p> <p>δ smaller</p> <p>long transmission lines and bulk power transmission</p>
 <p>Midpoint shunt reactance</p>	<p>$I_{s/c}$ almost unchanged</p> <p>δ slightly decreased</p> <p>V_{PCC} decreased</p> <p>Light load voltage stabilisation</p> $B_L = \frac{VAR_{demand} - VAR_{uncomp}}{V^2}$ <p>$L = 1 / \omega B_c$</p>	 <p>Midpoint series reactance</p>	<p>$I_{s/c}$ decreased</p> <p>δ increased</p> <p>short transmission lines and short circuit limiting</p>
 <p>Static VAR Compensator STATCOM</p>	<p>$I_{s/c}$ almost unchanged</p> <p>δ controlled</p> <p>V_{PCC} controlled</p> <p>fast voltage control</p> <p>reactive power control</p> <p>power damping</p>	 <p>Thyristor controlled series compensator</p>	<p>$I_{s/c}$ controlled</p> <p>δ controlled</p> <p>pf correction</p> <p>P Oscillator Damper</p> <p>Sub-Sync Resonance mitigation</p> <p>Fault current limiting</p>
<p>Steady state dynamic voltage control</p> <p>Reactive power control of dynamic loads</p> <p>Active power oscillation damping</p> <p>System stability improvement</p> <p>* $I_{s/c}$ short circuit current</p>		<p>Reduction of</p> <ul style="list-style-type: none"> load dependent voltage drops system transfer impedance transmission angle <p>Increase of system stability</p> <p>Load flow control</p> <p>Active power oscillation damping</p>	

Figure 25.5. HVAC transmission system reactive power shunt and series compensation methods.

Instantaneous power theory as presented should not be used with unbalanced or distorted supply voltages. When a linear load is supplied with distorted periodic voltage, the distortion caused by the supply voltage harmonics is still present in the source current after compensation.

In figure 25.5, series compensators compensate output voltage harmonics (by antiphasing them) while shunt compensators compensate output current harmonics (by bypassing the current harmonics).

25.5 FACTS devices

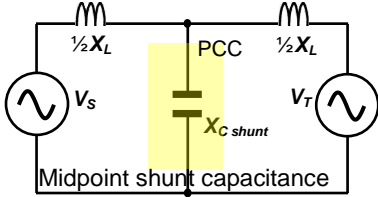
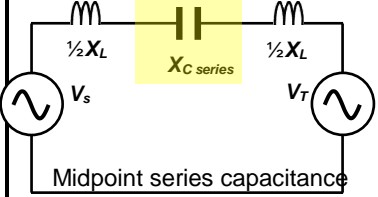
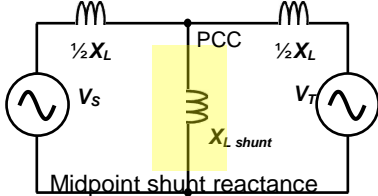
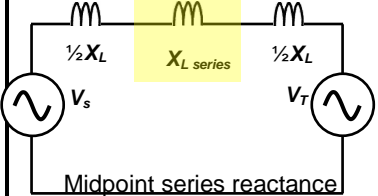
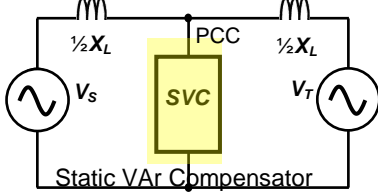
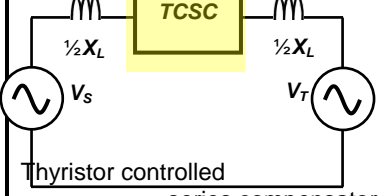
FACTS technology may be divided into two principal families (excluding switchgear devices):

- i.* line-commutated, thyristor based devices and
- ii.* self-commutated IGBT/IGCT devices.

i. Line-commutated FACTS

Line commutated FACTS may be considered as providing a means of inserting variable impedance either in parallel (shunt static VAR compensator, SVC) or in series (thyristor switched and thyristor controlled series compensation TSSC/TCSC). The use of thyristor technology readily achieves high-power handing capability with low losses and robust overload capability.

These devices have relatively slow response times, of the order of several ac cycles, due to the limits of line frequency switching and the inherent time constant of the thyristor controlled reactive component. Line frequency switching imposes a need for filters and damping networks to eliminate harmonics and low multiples of the power frequency. The FACTS response allows for compensation of sub-cycle transients but they do not have the bandwidth to compensate for higher frequency disturbances.

ii. Self-commutating FACTS devices

Unlike line-commutated devices, self-commutating FACTS act as controlled energy sources which are capable of injecting voltage or current at the point of common coupling (PCC). This mechanism provides better decoupling between the compensation function and network conditions. Such FACTS devices employ switching devices capable of switching at high multiples of the power frequency (typically in the range of 1 to 2kHz). This allows elimination of the low order harmonics associated with line-commutated systems. If required this increased bandwidth may be used to achieve active management of harmonics and transients at frequencies above the power frequency (active power filters, APF). Self-commutating FACTS operate as controlled sources that may inject shunt current (STATCOM) or series voltage (dynamic voltage restorer, DVR). Simultaneous series and shunt compensation may be achieved through the integration of both shunt and series devices (unified power flow controller, UPF).

Systems generally use pulse-width modulated (PWM) voltage source inverter (VSI) technology, similar to that employed in variable speed drives. However, since FACTS do not contribute real power, no external power source is required.

VSI based FACTS devices achieve faster response times, improved transient response, and reduced size relative to thyristor based systems. The size reduction results from the reduction in mains frequency rated reactive components. The use of PWM semiconductor switched devices increases losses both as a result of increased device conduction loss (relative to thyristors) and the increased loss associated with a high PWM switching frequency. Although low-frequency power harmonics are absent from the output spectrum, the output does contain harmonics at the switching frequency which must be removed using passive filters. These filters are smaller than those required for thyristor systems, however they may contribute to system resonances and incur damping loss.

Advances in self commutating FACTS devices

Since FACTS devices do not contribute to the principal power flow, there is the option for transformer matching between the network voltage and the ratings of power semiconductors. This allows the use of conventional two-level VSI technology, which differs from HVDC where there is a basic requirement for high-voltage conversion systems.

Raising the operating voltage of self-commutating FACTS has benefits in terms of increased VAR capability and direct transformerless connection. Increased operating voltage is achieved through series connection of semiconductors or by means of multi-level converters.

Multi-level converters synthesise an output voltage comprised of a number of discrete steps, each of which is within the voltage rating of each individual power semiconductor device. This technique extends the achievable operating voltage, resulting in significant improvements in waveform quality, reduced filter size, and decreased losses. Intermediate voltage levels are provided by capacitors in a similar manner to the dc link capacitor of a conventional two-level inverter. However these capacitors require continuous charge balancing and must be sized according to the principal fundamental current; unlike a conventional two-level inverter, where the capacitance experiences only the switching frequency and unbalance components. Power circuits and control of multi-level converters are more complex than those of two level systems.

Use of FACTS devices to improve network stability

FACTS devices have the ability to damp network oscillations through the selective sourcing and sinking of reactive power. To achieve this, the ratings of the FACTS reactive storage components must be sized such that sufficient energy may be stored and released in anti-phase with the oscillation.

25.6 Static reactive power compensation

In the steady state, FACTS devices are used to manage power flows by manipulating the reactive power and impedance seen at different points on the network. There are a number of basic modes to affect static VAR compensation in a transmission system:

- i. shunt compensation -
 - thyristor controlled reactor (TCR)
 - thyristor switched capacitor (TSC)
 - hybrid parallel connect TCR and TSC, termed a static VAR compensator (SVC)
 - voltage source inverter (STATCOM)
- ii. series compensation -
 - thyristor switched series capacitor (TSSC)
 - thyristor controlled series capacitor (TCSC)
 - hybrid parallel connected TCR and C, termed a static series VAR compensator (SVC)
- iii. static phase shift compensator (SPSC)
- iv. dynamic voltage restorer (DVR)
- v. combined shunt and series compensation, the unified power flow controller (UPFC)

Parallel (shunt) compensation is defined as any reactive power compensation utilising either switched or controlled devices, which are shunt connected at a selected network node, called the point of common coupling, (PCC) of the transmission system.

Shunt compensation compensates the system current harmonics, based on Kirchoff's current law.

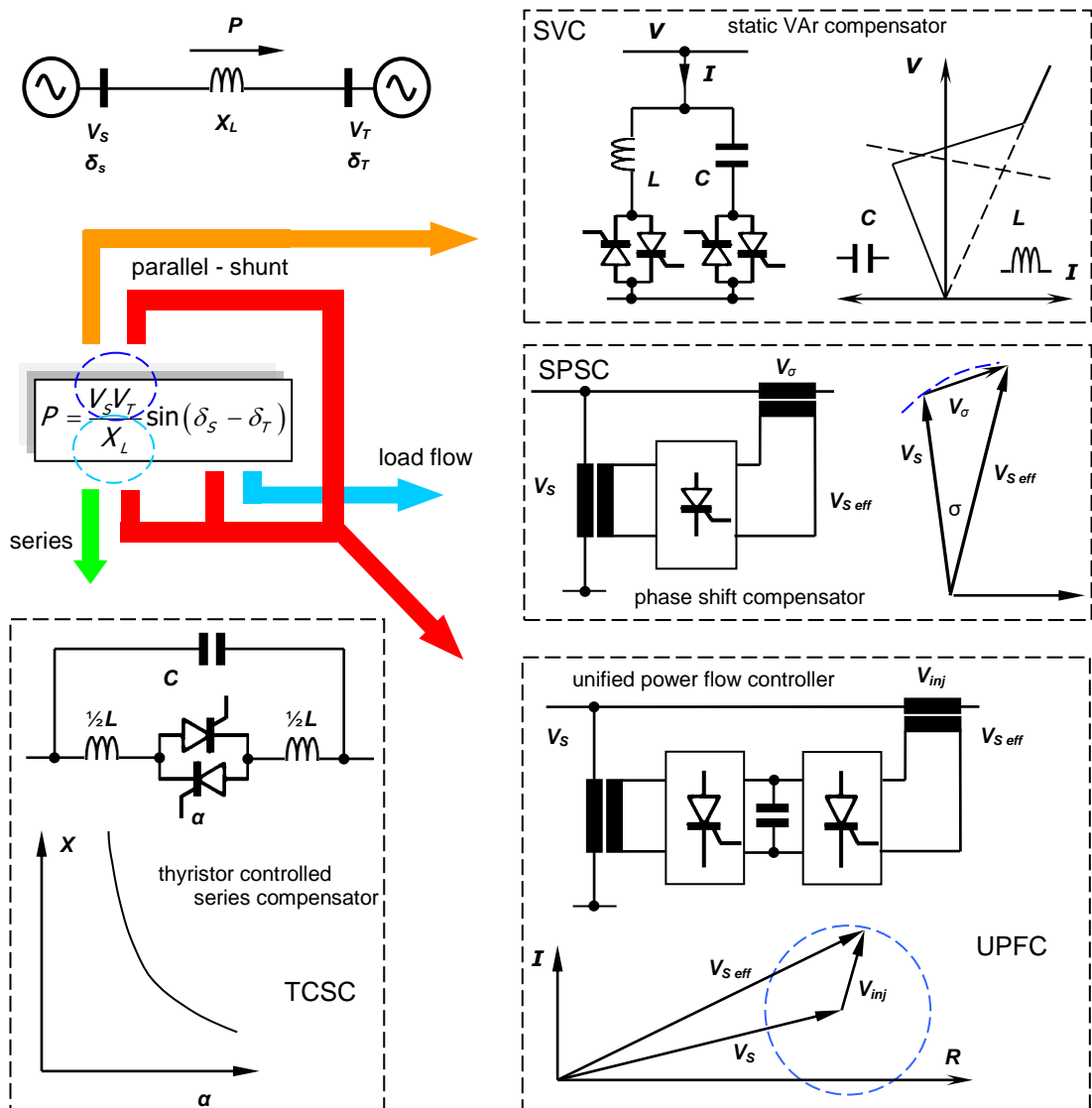

Figure 25.6. The influence of FACTS devices on the power transfer equation.

Series compensation is defined as any reactive power compensation utilising either switched or controlled devices, which are series connected into the transmission line at a selected node, called the point of common coupling, (PCC) of the transmission system.

Series compensation compensates the system voltage harmonics, based on Kirchhoff's voltage law

Compensators make use of capacitors, inductors and/or power electronic devices, and offer a higher transmission flexibility. Ideal compensators are lossless since their terminal voltage V_T and current I are at quadrature. Shunt compensators have minimal effect on the fault short circuit current level, $I_{s/c}$.

Figure 25.5 shows the basic transmission line connection of each type of static VAr compensator, and summaries their main characteristics. Their influence on the power transferred is shown in figure 25.6, which is based on equation (25.6). The relative terminating and sending angle difference is arranged into absolute terms as follows

$$P = \frac{V_s V_T}{X_L} \sin \delta = \frac{V_s V_T}{X_L} \sin(\delta_s - \delta_T) \tag{25.27}$$

25.7 Static shunt reactive power compensation

The objective of shunt compensation is to supply reactive power so as to increase the transmittable power by reducing the line voltage under light load conditions and increasing it under higher load conditions. The ideal compensator is lossless. It is located at the transmission line reactance midpoint and maintains the midpoint voltage such that $|V_s| = |V_T| = |V_M|$. Characteristically the generated and absorbed reactive powers are increased.

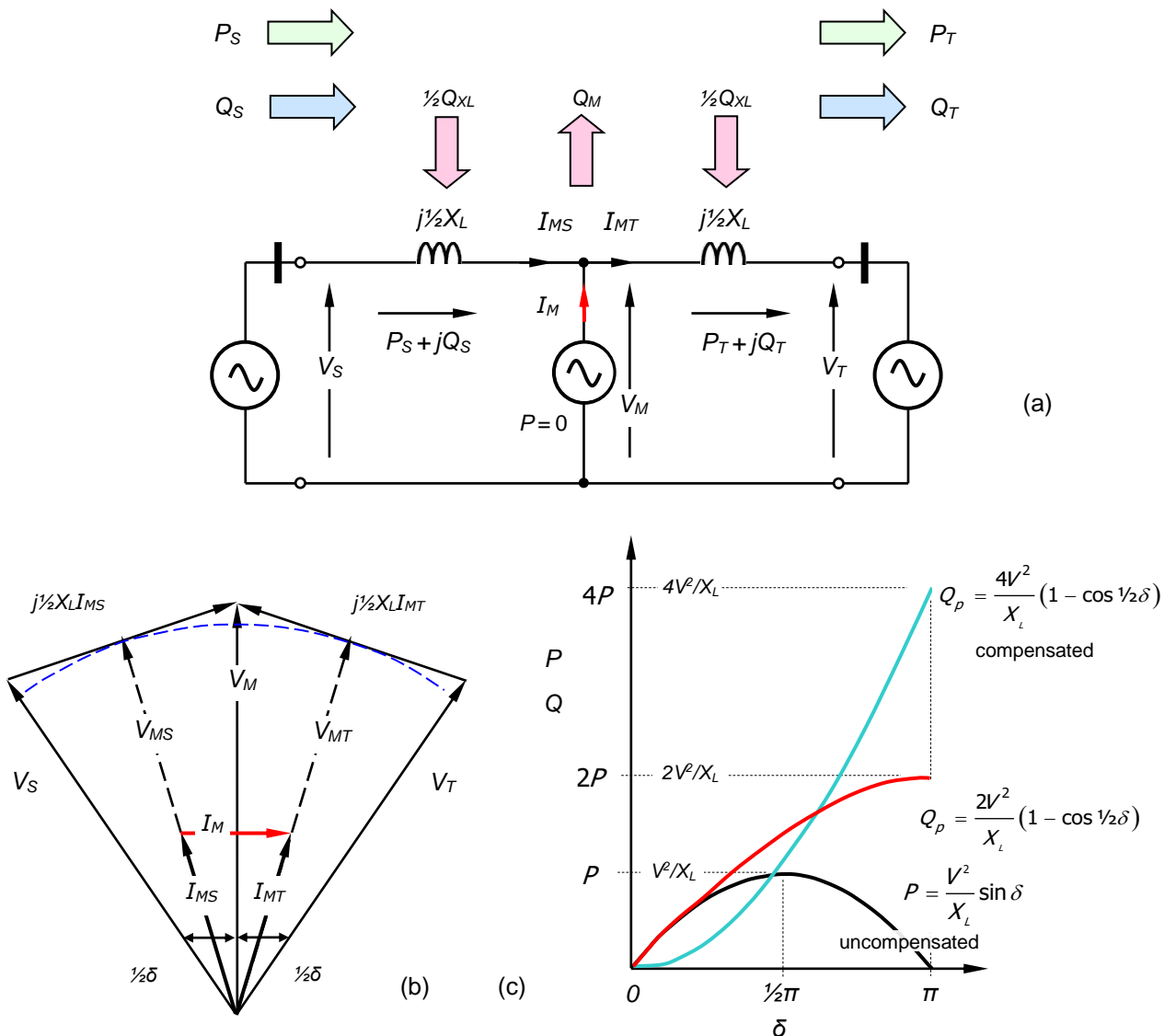

Figure 25.7. Midpoint shunt compensation: (a) two source power system model; (b) phasor diagram for $|V_s| = |V_T| = |V_M| = V$; and (c) power versus load angle.

Principle of shunt compensation

Ideally the sending, receiving, and midpoint voltage magnitudes are equal as shown in the compensated phasor diagram in figure 25.7b. The transmission line is then analysed as two independent halves. From this phasor diagram, with $V = V_M$, the newly created midpoint current and voltage magnitudes are

$$V_{MS} = V_{MT} = V \cos \frac{1}{4}\delta \quad (25.28)$$

$$I_{MS} = I_{MT} = I = \frac{4V}{X_L} \sin \frac{1}{4}\delta \quad (25.29)$$

With compensation, the transmitted active power is

$$\begin{aligned} P_p &= V_{MS} I_{MS} = V_{MT} I_{MT} = V_M I \cos \frac{1}{4}\delta = V I \cos \frac{1}{4}\delta \\ &= \frac{4V^2}{X_L} \sin \frac{1}{4}\delta \times \cos \frac{1}{4}\delta = \frac{2V^2}{X_L} \sin \frac{1}{2}\delta \end{aligned} \quad (25.30)$$

The reactive power Q_s generated at the sending end and absorbed by the terminal end, Q_T is

$$Q_s = -Q_T = VI \sin \frac{1}{4}\delta = \frac{4V^2}{X_L} \sin^2 \frac{1}{4}\delta = \frac{2V^2}{X_L} (1 - \cos \frac{1}{2}\delta) \quad (25.31)$$

The reactive power Q_p provided by the shunt compensator is

$$Q_p = |Q_s| + |Q_T| = 2VI \sin \frac{1}{4}\delta = \frac{8V^2}{X_L} \sin^2 \frac{1}{4}\delta = \frac{4V^2}{X_L} (1 - \cos \frac{1}{2}\delta) \quad (25.32)$$

As shown in figure 25.7c, after compensation the maximum transmittable power is doubled, when $\delta=180^\circ$ (which represent 90° across each half of the line) but at the expense of greatly increased VAR requirements, as seen in equations (25.31) and (25.32).

Shunt static VAR compensators

25.7.1 - Thyristor controlled reactor TCR

The basic phase angle controlled TCR is shown in figure 25.8b. If the thyristors are used purely as on/off switches with integral cycle control (without phase angle control) then the inductive arrangement is termed a thyristor switch reactor (TSR). Both modes are inductive thus are always associated with reactive power absorption.

Principle of TCR operation

The back-to-back connected thyristors conduct symmetrically on alternate half cycles of the ac supply.

$$\begin{aligned} i &= \frac{\sqrt{2}V}{\omega L_{sh}} (\cos \alpha + \cos \omega t) & \alpha < \omega t < \alpha + \sigma \\ &= 0 & \alpha + \sigma < \omega t < \alpha + \pi \end{aligned}$$

where $\sigma = 2(\pi - \alpha)$.

The operation of this configuration has been treated extensively in Chapter 15.1.1ii, where it was shown that continuous conduction occurs at a delay angle of 90° and partial symmetrical decreasing current (decreasing inductive VAR's) results for delay angles increasing from 90° to 180° , as shown in figure 25.8c. As the delay angle increases the fundamental current component decreases from a maximum, with the introduction of harmonics.

The power factor of the fundamental component lags by 90° , always absorbing reactive power. The odd order rms harmonics shown in figure 25.8d vary with delay angle according to

$$I_n = \frac{4}{\pi} \frac{V}{X_{Lsh}} \left[\frac{\sin(n+1)\alpha}{2(n+1)} + \frac{\sin(n-1)\alpha}{2(n-1)} - \frac{\sin n\alpha}{n} \cos \alpha \right] \quad \text{for } n = 3, 5, 7, \dots \quad (25.33)$$

or

$$I_n = \frac{4}{\pi} \frac{V}{X_{Lsh}} \left[\frac{\sin \alpha \cos n\alpha - \cos \alpha \sin n\alpha}{n(n^2 - 1)} \right]$$

and the 90° lagging fundamental rms is given by

$$\begin{aligned} I_1 &= \frac{2}{\pi} \int_{-(\pi-\alpha)}^{\pi-\alpha} \frac{V}{\omega L_{sh}} (\cos \alpha + \cos \omega t) \cos \omega t \, d\omega t \\ &= \frac{2}{\pi} \frac{V}{X_{Lsh}} \left[\frac{1}{2} \sin 2\alpha + \pi - \alpha \right] = B_L(\alpha) V \quad \text{where } X_{shL} = \omega L_{sh} \end{aligned} \quad (25.34)$$

for $\frac{1}{2}\pi \leq \alpha \leq \pi$ with respect to zero voltage cross-over.

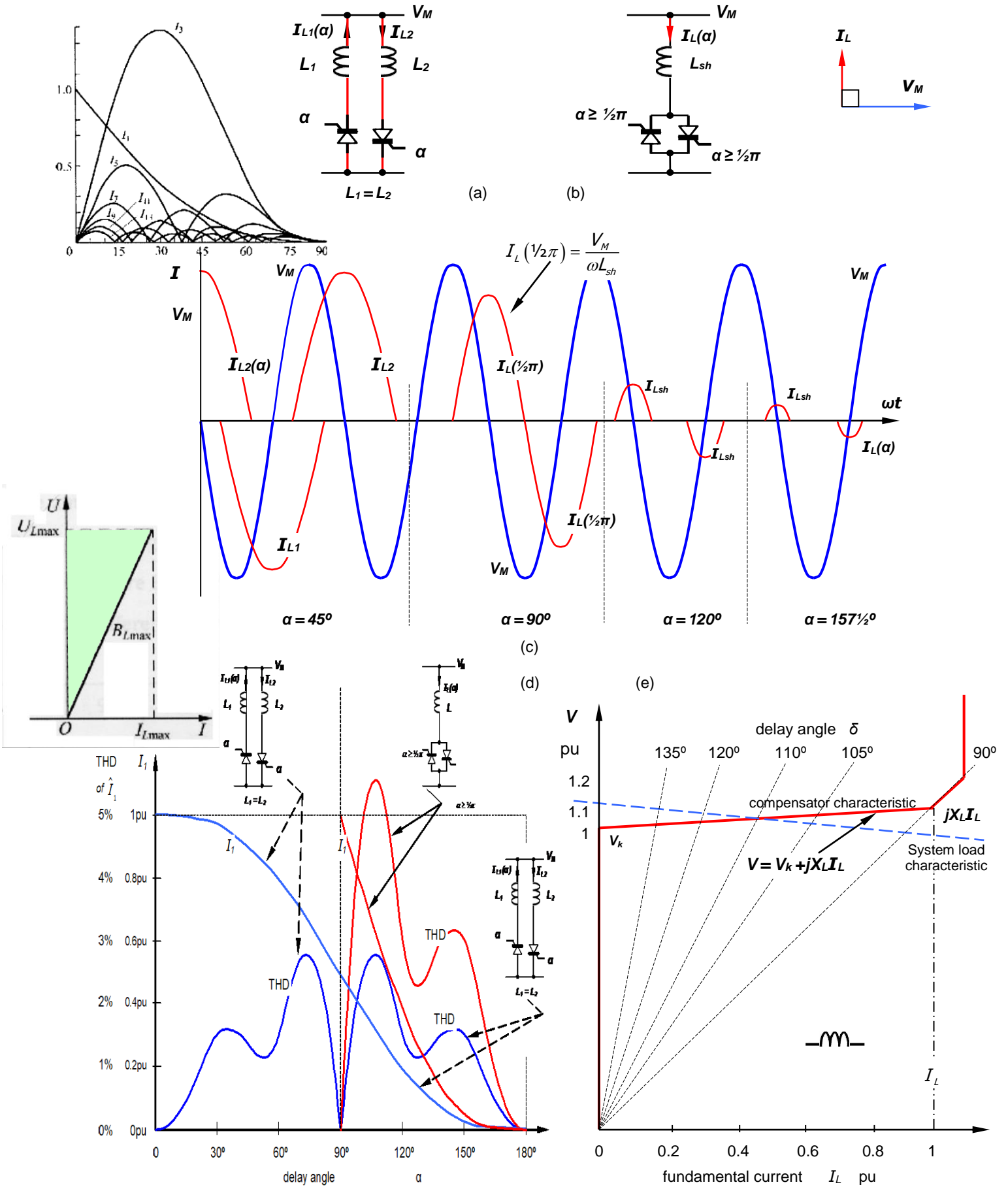

Figure 25.8. TCR compensation: (a) dual reactor TCR compensator; (b) single reactor TCR compensator; (c) line voltage and current waveforms for delay angles $\alpha=45^\circ, 90^\circ, 120^\circ$, and $157\frac{1}{2}^\circ$; (d) harmonics (delta connected - no triplens); and (e) fundamental I-V TCR characteristics.

If the delay angles of both thyristors are not equal, even harmonics are produced, including a dc component. The total harmonic distortion is increased.

As the delay angle increases the current conduction angle σ decreases and the current decreases, as if the inductance were increasing, so that the TCR effective acts like controllable shunt susceptance, B_L .

$$L_{eff} = \frac{V}{\omega I_1} \quad Q_1 = VI_1 = \frac{V^2}{\omega L_{eff}} \quad (25.35)$$

As the delay angle α increases and the current decreases, the thyristor and inductor conduction losses decrease. The maximum fundamental rms current component of $V/\omega L_{sh}$ occurs at $\alpha = 1/2\pi$.

If the three-phase TCR is configured in a delta arrangement, the third harmonic current does not appear in the source line voltage. If two separate reactors are used in each phase as in figure 25.8a, then conduction up to 360° is possible resulting in the maximum possible fundamental with lower total harmonics, although energy cycling between the two inductors occurs. Alternatively, if transformer coupling is used, then the 5th and 7th order current harmonics can be eliminated if two three-phase delta connected TCR are used with a 12 pulse star-delta transformer secondary arrangement. (Alternatively, two discrete transformers can be used.) The use of a transformer means that voltage levels can be matched (usually a voltage step-down transformer in HVAC systems so that series semiconductor thyristor device connection is avoided). High leakage inductance minimizes the necessary TCR discrete inductance required. Two discrete TCRs also offers redundancy possibilities. Further, a transformer offers the possibility of reducing the inrush current if used in conjunction with the capacitive TSC.

25.7.2 - Thyristor switched capacitor TSC

The basic shunt phase angle controlled TSC is shown in figure 25.9a, where the thyristors are usually operated either continuously conducting or off. Normally capacitor banks are switched in parallel to give line susceptance discrete level adjustment, since phase angle control is not possible because of the uncontrolled capacitive turn-on currents that would result. Beneficially, no harmonics are produced with continuous thyristor conduction. Transformer coupling can be used for voltage matching, the leakage of which helps control the initial current inrush. The capacitive VAR produced is determined by the capacitive current and the resultant system midpoint voltage, V_M :

$$I = \frac{V_M}{X_c} = \omega C V_M = B_C V_M \quad (25.36)$$

$$VAR = Q_p = V_M I = -\omega C V_M^2 = -B_C V_M^2$$

At thyristor turn-on, α , with inevitable series inductance, the current into the formed LC circuit is given by

$$i(t) = \frac{V}{X_c} \frac{n^2}{n^2 - 1} \cos(\omega t + \alpha) - \frac{n}{X_c} \left[V_{co} - \frac{n^2}{n^2 - 1} V \sin \alpha \right] \sin n\omega t - \frac{V}{X_c} \cos \alpha \cos n\omega t \quad (25.37)$$

where $n = \frac{\omega_0}{\omega} = \sqrt{\frac{X_c}{X_{Lsh}}}$ and ω is the supply frequency and $\omega_0 = 1/\sqrt{LC}$.

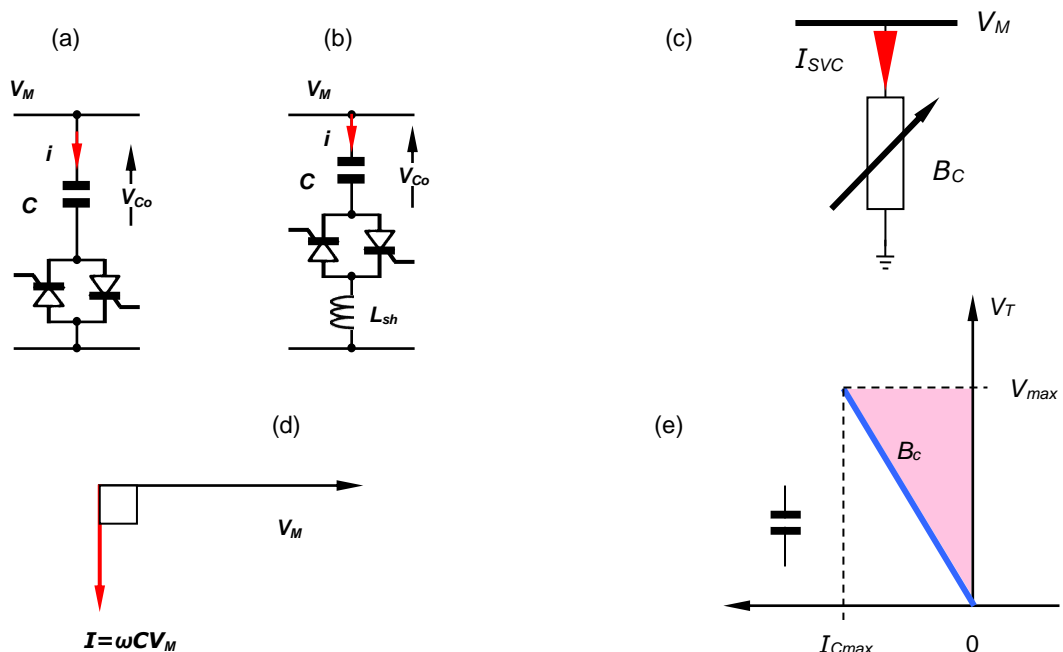

Figure 25.9. Thyristor switched capacitor compensation: (a) ideal capacitor TSC compensator; (b) capacitor TSC compensator with line/leakage inductance; (c) variable susceptance representation; (d) I-V TSC phasor characteristics; and (e) I-V TSC susceptance characteristics.

Equation (25.37) can be used to determine the necessary phase angle condition for transient free switch-in of the capacitors.

The oscillatory components, the second and third terms in equation (25.37), are zero when

$$\cos \alpha = 0, \text{ hence } \sin \alpha = \pm 1 \tag{25.38}$$

$$\text{then } V_{co} = \mp \frac{n^2}{n^2 - 1} V \tag{25.39}$$

The first condition implies thyristor turn-on at either ac peaks or troughs. The second condition implies that the capacitors be pre-charged, then the start up current is given by (first term in equation (25.37))

$$i(t) = \frac{V}{X_c} \frac{n^2}{n^2 - 1} \sin \omega t \tag{25.40}$$

Such initial conditions are usual impractical, and a turn-on angle compromise is used which results in acceptable oscillatory transient currents.

For capacitor disconnection, when the anode current reaches zero, the thyristors are no longer triggered, the system reactive energy changes abruptly and each capacitor retains a voltage

$$V_{co} = \pm V \frac{n^2}{n^2 - 1} \tag{25.41}$$

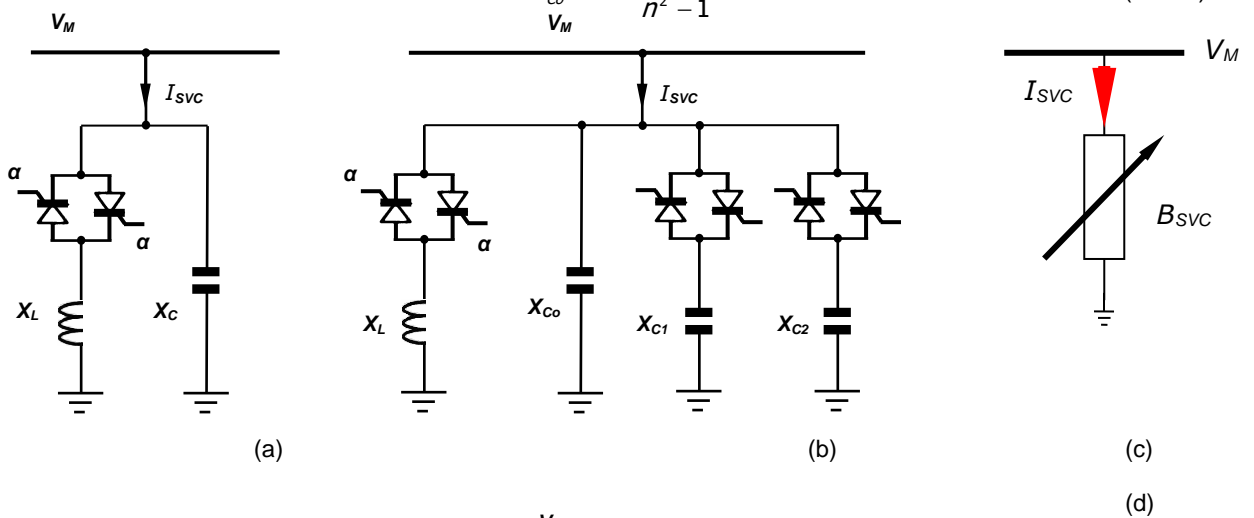

Figure 25.10. Static VAR compensator (SVC): (a) basic SVC; (b) SVC with capacitor banks; (c) variable susceptance model representation; and (d) I-V SVC characteristics.

25.7.3 - Shunt static VAR compensator SVC (TCR/TSC)

A static VAR compensator is comprised of a thyristor controlled reactor compensator and a thyristor switched capacitor compensator as shown in figure 25.10a. The leading reactive power is provided in discrete equal steps (or 2^n steps) by banks of thyristor switched capacitor compensators (TSC) and precise continuous VAR adjustment is affected by a thyristor controlled reactor compensator (TCR). The maximum lagging current from the TCR is equal to the incremental capacitive leading current, such that the two can cancel to zero giving zero net reactive VA. As the phase angle of the TCR is increased, the net leading VAR increases. At zero TCR conduction, a capacitive bank is decremented and the TCR starts with full conduction, that is zero delay angle.

Ideally, no active power is drawn from the system and the reactive power depends on the net fundamental impedance of the parallel capacitor-reactance combination, which is TCR delay angle dependent.

$$P_{SVC} = 0$$

$$Q_{SVC} = -\frac{V_M^2}{X_{SVC}} = -V_M^2 B_{SVC} \quad (25.42)$$

The SVC is usually transformer coupled for voltage matching of the thyristors. The compensator bus usually incorporates permanent LC notch filters to minimise the injection of 5th and 7th order harmonics, produced by the TCR, back into the HV system.

An advanced SVC that uses a voltage source inverter is called a static compensator, or STATCOM.

Example 25.2: Shunt thyristor controlled reactor specification

A 50Hz 400V ac transmission line has line reactance of $X_L = 2.2 \Omega$ and is delivering 100kW.

Calculate

- i. the load angle δ
- ii. the line current
- iii. the TCR and line reactive powers
- iv. the TCR current and reactance and inductance at this current (with $V_M = 400V$)
- v. the 50Hz reactance, thence inductance if the maximum TCR current is 100A (1.0 pu)
- vi. the TCR triggering delay angle, hence thyristor conduction period, if the reactor current is 0.5pu
- vii. the effective reactance, inductance, and the reactive power at a TCR current of 0.5pu
- viii. delay angle α for $V_M = 400V$, if the TCR inductance is 5mH

Solution

- i. Rearrangement of equation (25.30) gives the transmission load angle

$$\delta = 2 \sin^{-1} \left(\frac{P_p X_L}{2V^2} \right) = 2 \sin^{-1} \left(\frac{100kW \times 2.2\Omega}{2 \times 400V^2} \right) = 86.86^\circ$$

- ii. Equation (25.29) gives the transmission line current

$$I = \frac{4V}{X_L} \sin \frac{1}{2} \delta = \frac{4 \times 400V}{2.2\Omega} \sin \left(\frac{1}{2} \times 88.7^\circ \right) = 269A$$

- iii. The reactive power given by equation (25.32) is

$$Q_p = |Q_s| + |Q_r| = \frac{4V^2}{X_L} (1 - \cos \frac{1}{2} \delta) = \frac{4 \times 400V^2}{2.2\Omega} (1 - \cos \frac{1}{2} \times 88.7^\circ) = 79,647VAr$$

$$Q_s = -Q_r = \frac{1}{2} Q_p = 39,823VAr$$

- iv. The TCR current is

$$I_{Q_p} = \frac{Q_p}{V} = \frac{82.445 \times 10^3 VAr}{400V} = 199A$$

$$X_p = \frac{V}{I_{Q_p}} = \frac{400V}{207.2A} = 2\Omega \Rightarrow L = \frac{X_p}{2\pi f} = \frac{1.93\Omega}{2\pi \times 50Hz} = 6.37mH$$

- v. At 100A the TCR inductance at the fundamental frequency, 50Hz, is

$$X_p = \frac{V}{I_Q} = \frac{400V}{100A} = 4.0\Omega \quad \text{thence} \quad L_p = \frac{X_p}{2\pi f} = \frac{4.0\Omega}{2\pi \times 50Hz} = 12.7mH$$

- vi. Solving equation (25.34) gives the transmission angle for a TCR current of 50A

$$I_1 = \frac{2}{\pi} \frac{V}{X_L} [\frac{1}{2} \sin 2\alpha + \pi - \alpha]$$

$$50A = \frac{2}{\pi} \frac{400V}{4.0\Omega} [\frac{1}{2} \sin 2\alpha + \pi - \alpha]$$

$$0 = \frac{1}{2} \sin 2\alpha - \alpha + \frac{3}{4}\pi \Rightarrow \alpha = 113.8^\circ$$

vii. The effective inductance and reactive power are given by equation (25.35)

$$L_{eff} = \frac{V}{2\pi f I_1} = \frac{400V}{2\pi \times 50Hz \times 50A} = 25.5mH$$

$$Q_1 = VI_1 = \frac{V^2}{\omega L_{eff}} = 400V \times 50A = 20 \times 10^3 \text{ VAR}$$

vii. From part iv, the effective inductance for 400V is 6.14mH, or 1.93Ω with 207.2A at the fundamental frequency.

$$L = L_{eff} \frac{2}{\pi} [\frac{1}{2} \sin 2\alpha + \pi - \alpha]$$

$$5mH = 6.37mH \times \frac{2}{\pi} [\frac{1}{2} \sin 2\alpha + \pi - \alpha] \Rightarrow \alpha = 99.8^\circ$$



25.8 Static series reactive power compensation

Transmission line capability can be increased by installing series compensation in order to reduce the transmission line net series reactance. Effectively the apparent transmission line length is varied. The insertion of inductance decreases transmission capability, but may be used to limit fault levels or to divert power flow, while the insertion of series capacitance acts to cancel the series inductive voltage drop, reducing the net line impedance, thus:

- increases power flow capability, loadability, and stability margins;
- reduces the transmission load angle;
- increases the virtual load (reduces line and load dependant voltage drops); and
- provides a means of increasing responsiveness and damping power oscillations.

Normally, series compensation is capacitive. Since distributed compensation along the line is impractical, as with shunt compensation, series compensation is normally inserted at the reactance midpoint. Series compensation is normally only used on very long ac transmission lines, thereby making long distance ac transmission viable. The enhanced power flow results in additional losses in the compensated line.

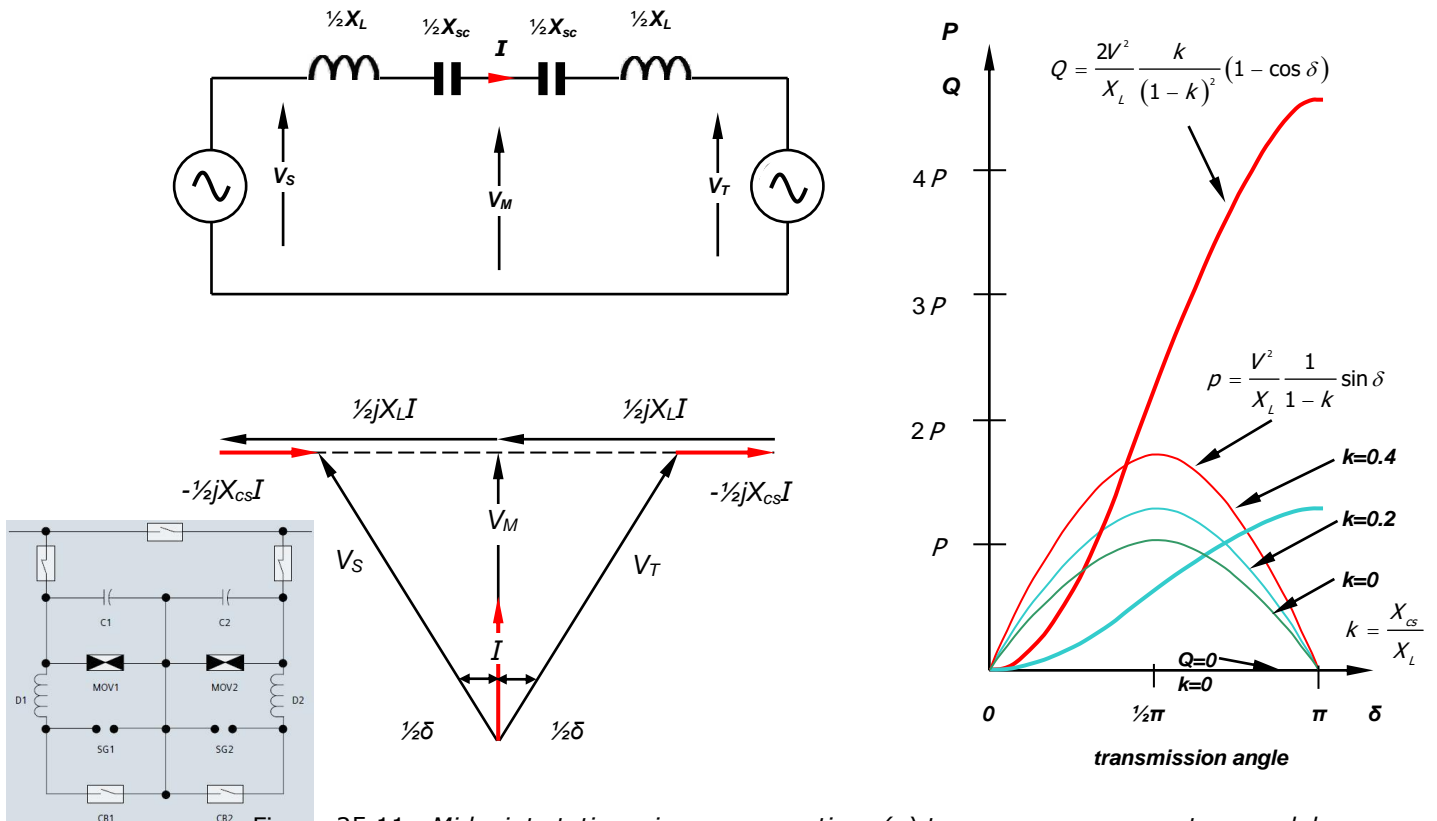

Figure 25.11. Midpoint static series compensation: (a) two source power system model; (b) phasor diagram for $|V_S| = |V_T| = V$; and (c) power versus load angle.

Fixed-series compensation

Series capacitors offer advantages over shunt counterparts. With series capacitors, the reactive power increases as the square of line current, whereas with shunt capacitors, the reactive power is generated proportional to the square of bus voltage. For achieving the same system benefits as those of series capacitors, shunt capacitors that are three to six times more reactive power-rated than series capacitors need to be employed. Furthermore, shunt capacitors typically must be connected at the line midpoint, whereas no such requirement exists for series capacitors.

Let Q_{se} and Q_{sh} be the ratings of a series and shunt capacitor, respectively, to achieve the same level of power transfer through a line that has a maximum angular difference of δ_{max} across its two ends, as shown in the phasor diagram in figure 25.11b. Then

$$\frac{Q_{se}}{Q_{sh}} = \tan^2 \frac{1}{2} \delta_{max}$$

Specifically, for δ_{max} of 35° , Q_{se} will be approximately 10% of Q_{sh} . Even though series capacitors are almost twice as costly as shunt capacitors (per-unit VAr) because of their higher operating voltages, the overall cost of series compensation is lower than shunt compensation.

Principle of series compensation

The ideal series compensator is effectively pure reactance, without any power loss. The ideal series line compensation of a transmission line is shown in figure 25.11a, where the compensator voltage is at quadrature to the line current. The line resistance is neglected. The effective line reactance is given by

$$X_{eq} = X_L - X_{sc} = X_L(1 - k) \quad (25.43)$$

where $k = X_{sc}/X_L$ is the degree of series compensation. If the compensation is inductive the reactance is negative and k is negative ($k < 0$), while k is positive for capacitive compensation ($k > 0$). Assuming $V_S = V_T = V$, then from equation (25.11), the line current, midpoint voltage, transmitted power, and reactive power are

$$\begin{aligned} \mathbf{I} &= \frac{2V}{X_L(1-k)} \sin \frac{1}{2} \delta \quad \angle 0 \\ \mathbf{V}_m &= V \cos \frac{1}{2} \delta \quad \angle 0 \\ P_{sc} &= \frac{V^2}{X_L(1-k)} \sin \delta \quad \left(= \frac{V^2}{X_L - X_{sc}} \sin \delta \right) \\ Q_{sc} &= \frac{2V^2}{X_L} \times \frac{k}{(1-k)^2} (1 - \cos \delta) \end{aligned} \quad (25.44)$$

The voltage across the compensation element, as shown in the phasor diagram in figure 25.11b, at quadrature to the line current, is

$$V_{sc} = IX_{sc} \quad (25.45)$$

The power equations are shown plotted in figure 25.11c. This figure shows that increased capacitance ($k > 0$), increases the transmittable power and the reactive power. Maximum power is transmitted with a load angle of $\delta = \frac{1}{2}\pi$, when $k \rightarrow 1$, that is when $\omega L_L = 1/\omega C_{sc}$ (line resonance at frequency ω).

Optimising operating conditions in terms of the load, $Z_{load} \angle \varphi = V_T / I = V / I$, then the power absorbed by the load, with a source reference $V_s \angle 0$

$$P_{load} = \frac{V_s Z_{load} \cos \varphi}{(1-k)^2 X_L^2 + Z_{load}^2 + 2(1-k) X_L Z_{load} \sin \varphi}$$

where the load voltage V_T is

$$V_T = \frac{V_s Z_{load}}{\sqrt{(1-k)^2 X_L^2 + Z_{load}^2 + 2(1-k) X_L Z_{load} \sin \varphi}}$$

If $Z_{load} = (1-k) X_L$, maximum power is absorbed by the load, specifically

$$\hat{P}_{load} = \frac{V_s^2}{2(1-k) X_L} = \frac{V_s^2}{2X_{eq}}$$

Series static VAr compensators

25.8.1 - Thyristor switched series capacitor TSSC

A thyristor switched series capacitor compensator TSSC consists of a least one series capacitor, each shunted by a back-to-back pair of anti-parallel connected phase control thyristors, as shown in figure 25.12a (shunt circuit breakers are not shown). The thyristors when continuously triggered, provide a path for the line current to by-pass the series compensating capacitors. The thyristors are taken out of circuit when the gate triggering is removed and natural turn-off commutation occurs at the subsequently line current reversal, that is, the thyristors are line or naturally commutated. With this commutation process, the series capacitor charges with a dc bias as shown in figure 25.12b. Subsequent thyristor turn-on should only occur at the line zero current points in order to avoid high initial anode di/dt currents.

25.8.2 - Thyristor controlled series capacitor TCSC

Better capacitor series voltage control is obtained if the thyristors in figure 25.12a are self-commutable, such as with symmetrical voltage blocking IGCThyristors. This series TCSC compensator is the dual to the shunt TSR in figure 25.8b.

- Instead of thyristors in series with inductance, thyristors are in parallel with capacitance.
- Instead of uni-directional voltage blocking, naturally commutating switches, the capacitive series compensator uses bidirectional voltage blocking, self-commutable switches.
- In the series compensator, compensation occurs when the series thyristors are on, while compensation is active in the series compensator case when the parallel IGC Thyristors are off.
- The shunt compensator supports a sinusoidal voltage and produces current harmonics, while the series compensator conducts the sinusoidal line current and produces voltage harmonics.

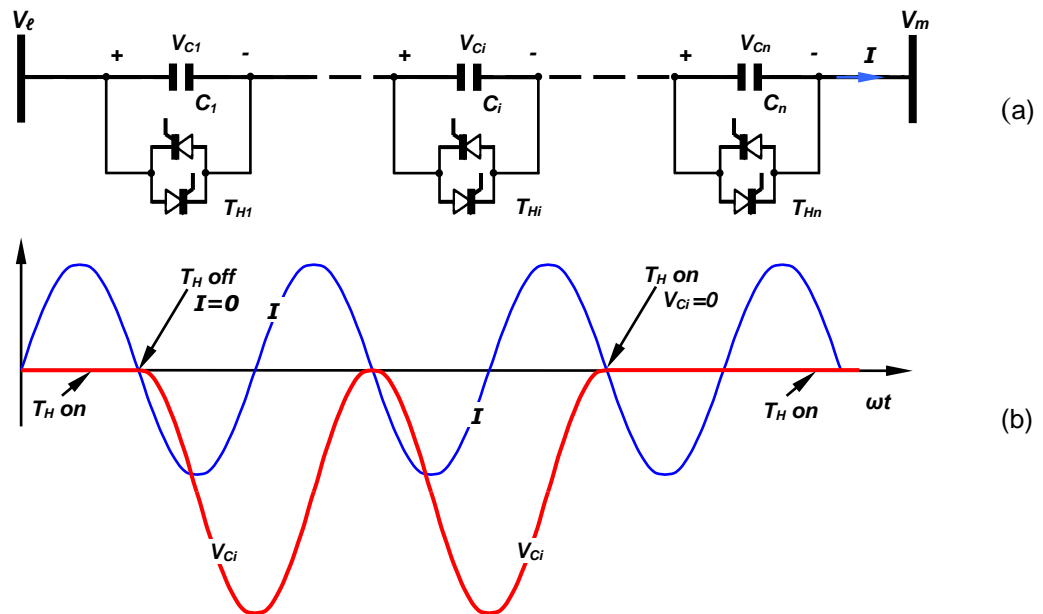

Figure 25.12. Thyristor switched series capacitor compensation TSSC: (a) series connected capacitors and (b) zero current activation and zero voltage deactivation.

Typical series TCSC waveforms are shown in figure 25.13c, while the harmonics produced are shown in figure 25.8d. It will be noted that the same equations as in section 25.2.4i for the TCR hold, except that voltages and currents are interchanged, and capacitive reactance is used instead of inductive reactance. Specifically, if the line current is

$$i = I_M \sin \omega t = \sqrt{2} I \sin \omega t \quad (25.46)$$

Then the capacitor voltage is given by

$$v_c(t) = I_M X_c (\cos \alpha + \cos \omega t) = \frac{I_M}{\omega C} (\cos \alpha + \cos \omega t) \quad (25.47)$$

The power factor of the fundamental voltage component lags I by 90° , always producing reactive power.

The odd order rms (total) harmonics shown in figure 25.8d vary with delay angle according to

$$V_n = \frac{4}{\pi} I X_c \left[\frac{\sin(n+1)\alpha}{2(n+1)} + \frac{\sin(n-1)\alpha}{2(n-1)} - \frac{\sin n\alpha}{n} \cos \alpha \right] \quad \text{for } n = 3, 5, 7, \dots \quad (25.48)$$

and the 90° lagging fundamental rms voltage is given by

$$V_1 = \frac{2}{\pi} \frac{I}{\omega C} [\frac{1}{2} \sin 2\alpha + \pi - \alpha] = \frac{2}{\pi} I X_c [\frac{1}{2} \sin 2\alpha + \pi - \alpha] \quad \text{where } X_c = 1 / \omega C \quad (25.49)$$

for $\frac{1}{2}\pi \leq \alpha \leq \pi$ with respect to zero current cross-over.

If the delay angles of both thyristors are not equal, even voltage harmonics are produced, including a dc voltage component. The total harmonic distortion is increased.

As the delay angle increases the voltage period angle σ decreases and the voltage decreases, as if the capacitance were increasing, so that the series TCSC effective acts like controllable capacitive susceptance.

$$C_{eff} = \frac{I}{\omega V_1} \quad (25.50)$$

$$Q_1 = V_1 I = \frac{I^2}{\omega C_{eff}} = I^2 X_{eff}$$

Also, as the delay angle α increases and the voltage decreases, thyristor conduction increases, hence thyristor losses increase.

As with the shunt TCR, operation below 90° is possible if two capacitors are used as shown in figure 25.13b. Extra semiconductors (diodes) are needed, but the IGC Thyristors only need forward voltage blocking properties. Consequently, capacitors with uni-directional voltage properties can be used. The voltage harmonics are lower but at the expense of extra devices and losses.

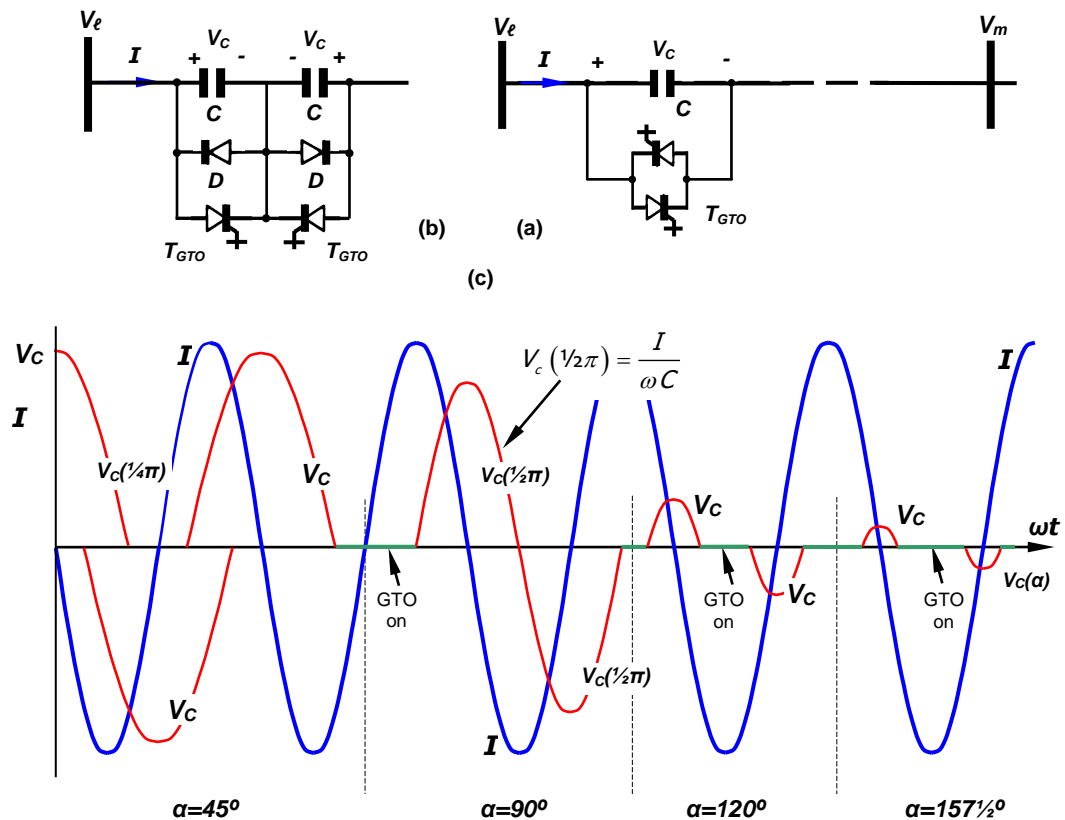

Figure 25.13. Thyristor controlled series capacitor compensation TCSC: (a) series connected capacitors with shunt self-commutable GTOs for $\alpha \geq 90^\circ$; (b) for $\alpha \geq 0^\circ$; and (c) line current and current waveforms for delay angles $\alpha = 45^\circ, 90^\circ, 120^\circ$ and $157\frac{1}{2}^\circ$.

25.8.3 - Series static VAR compensator SVC (TCR/C)-TCSC

The TCR/C consists of a line series compensating capacitor in parallel with a thyristor controlled reactor (TCR), as shown in figure 25.14. By varying the delay angle of the TCR thyristors, the capacitive reactance can be decreased, since the fundamental reactance of the parallel combination is given by

$$X_{eff}(\alpha) = \frac{X_C X_{L1}(\alpha)}{X_C - X_{L1}(\alpha)} \tag{25.51}$$

where, from equation (25.34), the reactance at the fundamental frequency is

$$X_{L1}(\alpha) = \frac{1/2\pi}{1/2 \sin 2\alpha + \pi - \alpha} X_L \quad \text{where } X_L = \omega L \tag{25.52}$$

The voltage harmonics produced by the reactor tend to be trapped in the parallel connected capacitor due to its the low capacitive reactance X_C which is inversely proportion to harmonic frequency (relative to line reactance X_s which increases proportionally to harmonic frequency).

Accounting for the line reactance X_s and compensator fundamental reactance X_{eff} , the active and sending reactive powers are given by equations (25.6) and (25.8), that is

$$P_T = \frac{V_S V_T}{X_L + X_{eff}} \sin(\delta_S - \delta_T) \tag{25.53}$$

$$Q_S = V_S \times \frac{V_S - V_T \cos(\delta_S - \delta_T)}{X_L + X_{eff}}$$

The signs in these equations are appropriately changed for capacitive operation.

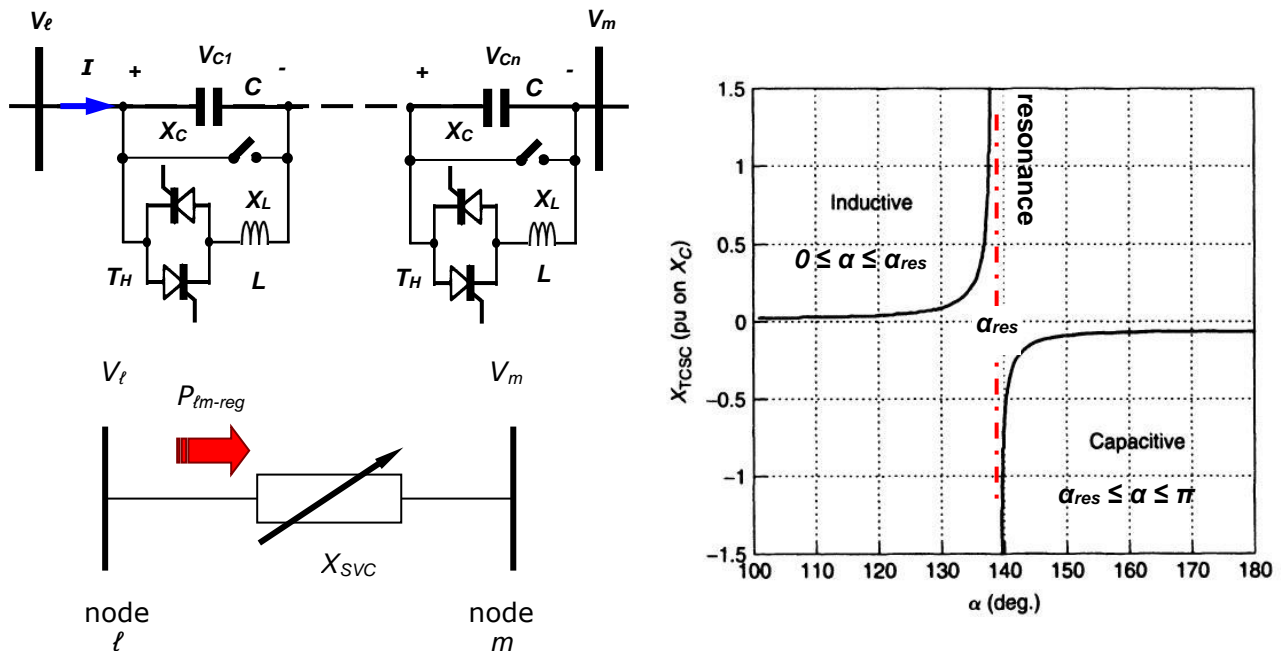

Figure 25.14. Thyristor controlled reactance and series connected capacitance, SVC compensation, variable reactance model representation, and variation of TCSC reactance with firing angle α .

The capacitor and inductor voltages and currents can be define during the period when the thyristors block and when a thyristor conducts. If the rms line current is I_M then

- when the thyristors block:

$$V_c(t, \alpha) = \sqrt{2} I_M X_C [\sin \alpha [1 - \sin(\omega t - \alpha)] - \cos \alpha \cos(\omega t + \alpha)] + V_{Ct=\alpha+\sigma}$$

$$I_c(t, \alpha) = \sqrt{2} I_M \sin \omega t \quad (= \text{line current}) \tag{25.54}$$

$$I_{Th} = I_L = 0 \quad \text{and} \quad V_L(t, \alpha) = 0$$

- when a thyristor conducts:

$$V_L(t, \alpha) = V_c(t, \alpha) = \sqrt{2} I_M X_L \frac{\omega k^2}{1 - k^2} \cos \alpha \left[\begin{aligned} & [\cos(\omega t - \alpha) - k \sin(\omega_0 t - k(\alpha - 1/2\pi))] \\ & - [\sin(\omega t - \alpha) - \cos(\omega_0 t - k(\alpha - 1/2\pi))] \end{aligned} \right] \tag{25.55}$$

$$+ V_{Ct=\alpha} \cos(\omega_0 t - k(\alpha - 1/2\pi))$$

$$I_L(t, \alpha) = \sqrt{2}I_M \frac{k}{1-k^2} \left[\begin{array}{l} \sin \alpha \left[\sin(\omega_o t - (\alpha - \frac{1}{2}\pi)/k) - k \cos(\omega t - \alpha) \right] \\ - \cos \alpha \left[\cos(\omega_o t - (\alpha - \frac{1}{2}\pi)/k) + \sin(\omega t - \alpha) \right] \end{array} \right] \quad (25.56)$$

$$I_C(t, \alpha) = I_L(t, \alpha) + \sqrt{2}I_M \sin \omega t$$

where $\omega_o = \frac{1}{\sqrt{LC}} = k\omega = 2\pi f$, that is, $k = \frac{\omega_o}{\omega} = \sqrt{\frac{X_C}{X_L}}$

The equivalent TCSC reactance is

$$X_{TCSC} = X_C \left(1 - \frac{k^2}{k^2-1} \frac{2\alpha + \sin 2\alpha}{\pi} + \frac{4k^2}{k^2-1} \frac{\cos^2 \alpha}{k^2-1} \frac{k \tan k\alpha - \tan \alpha}{\pi} \right) \quad (25.57)$$

The variation of per-unit TCSC reactance, (X_{TCSC}/X_C), as a function of firing angle α is shown in figure 25.14. From equation (25.57) parallel resonance is created between X_L and X_C at the fundamental frequency, corresponding to the values of firing angle α_{res} , given by

$$\alpha_{res} = \pi - (2m-1) \frac{\pi\omega}{2\omega_o}; \quad m = 1, 2$$

Advantages of the TCSC

Use of thyristor control with series capacitors offers the following advantages:

1. Rapid, continuous control of the transmission-line series-compensation level.
2. Dynamic control of power flow in selected transmission lines within the network to enable optimal power-flow conditions and prevent the loop flow of power.
3. Damping of the power swings from local and inter-area oscillations.
4. Suppression of sub-synchronous oscillations. At sub-synchronous frequencies, the TCSC presents an inherently resistive-inductive reactance. The sub-synchronous oscillations cannot be sustained in this situation and consequently are damped.
5. Decreasing dc-offset voltages. The dc-offset voltages, invariably resulting from the insertion of series capacitors, can be made to decay quickly (within a few cycles) from the firing control of the TCSC thyristors.
6. Enhanced level of protection for series capacitors. A fast bypass of the series capacitors can be achieved through thyristor control when large over-voltages develop across capacitors following faults. Likewise, the capacitors can be quickly reinserted by thyristor action after fault clearing to aid in system stabilization.
7. Voltage support. The TCSC, in conjunction with series capacitors, can generate reactive power that increases with line loading, thereby aiding the regulation of local network voltages and, in addition, the alleviation of any voltage instability.
8. Reduction of the short-circuit current. During events of high short-circuit current, the TCSC can switch from the controllable-capacitance to the controllable-inductance mode, thereby restricting the short-circuit currents.

Example 25.3: Series thyristor controlled reactor specification – integral control

A 50Hz 230kV three-phase ac transmission line has line reactance of $X_L = 52 \Omega$ per phase and a maximum thermally limited line current of 2000A. The line voltage can vary by $\pm 5\%$ at each end and the load angle between the ends varies between 5° and 10° , where the load is lagging.

Series TCSC SVC connected at the midpoint, comprised of four compensating three-phase modules has a capacitive reactance of 10Ω with 1.66Ω of switchable parallel inductance.

Calculate:

- i. the nominal power
- ii. the line current and powers under worst case conditions, before series compensation
- iii. the effective module reactance when the impedances are parallel connected
- iv. the effective line impedance at worst case, if 50% of rated power is the transmission objective, and the resultant transmission powers

Solution

- i. The nominal maximum power is given by

$$\begin{aligned} P &= \sqrt{3}V_L I_L \\ &= \sqrt{3} \times 230V \times 2000A = 796MW \end{aligned}$$

ii. Worst case power delivery conditions are when the sending end is 5% below the nominal voltage, while the receiving end is 5% above the nominal, at the highest load angle, $\delta=10^\circ$. The current can be evaluated by equating equation (25.1) with equations (25.6) and (25.7).

$$I = I \cos \phi + jI \sin \phi = I \times e^{j\phi}$$

$$\begin{aligned} I \sin \phi &= \frac{V_S \cos \delta - V_T}{X_L} = \frac{Q_T}{V_T} & I \cos \phi &= \frac{V_S \sin \delta}{X_L} = \frac{P}{V_T} \\ &= \frac{218.5\text{kV} \times \cos 10^\circ - 241.5\text{kV}}{52\Omega} & &= \frac{218.5\text{kV} \times \sin 10^\circ}{52\Omega} \\ &= -0.5051\text{kA} & &= 0.730\text{kA} \end{aligned}$$

$$I = -505.1 + j730.0 = 887.7^{-j55.3^\circ} \text{ pu wrt } V_T$$

The real power flow is:

$$\begin{aligned} P &= \frac{V_T \times V_R}{X_L} \sin \delta \\ &= \frac{218.5\text{kV} \times 241.5\text{kV}}{52\Omega} \sin 10^\circ = 176.2\text{MW} \end{aligned}$$

The sending end reactive power is

$$\begin{aligned} Q_s &= V_S \times \frac{V_S - V_T \cos \delta}{X_L} \\ &= 218.5\text{kV} \times \frac{218.5\text{kV} - 241.5\text{kV} \times \cos 10^\circ}{52\Omega} = -81.2\text{MVar} \end{aligned}$$

The terminal end reactive power is

$$\begin{aligned} Q_T &= V_T \frac{V_S \cos \delta - V_T}{X_L} \\ &= 241.5\text{kV} \times \frac{218.5\text{kV} \times \cos 10^\circ - 241.5\text{kV}}{52\Omega} = -122.2\text{MVar} \end{aligned}$$

The line reactive power is given by $Q_s - Q_T = -81.2\text{MVar} + 122.2\text{MVar} = 41.0\text{MVar}$.

Alternatively, the line reactive power can be calculated from $I^2 X_L = 887.7^2 \times 52 = 41.0\text{MVar}$

iii. The inductor $j1.66\Omega$ in parallel with the capacitor $-j10\Omega$ give a parallel combination impedance of

$$\begin{aligned} X_{cell} &= \frac{-jX_{cap} \times jX_{ind}}{-jX_{cap} + jX_{ind}} \\ &= \frac{-j10\Omega \times j1.66\Omega}{-j10\Omega + j1.66\Omega} = j2\Omega \end{aligned}$$

iv. Worst case power delivery conditions are when the sending end is 5% below the nominal voltage, while the receiving end is 5% above the nominal, at the highest load angle, δ . That is, the necessary line reactance, for half-rated power, is given by

$$\begin{aligned} P &= \frac{V_T \times V_R}{X_L} \sin \delta = \frac{95\%V_{Nom} \times 105\%V_{Nom}}{X_L} \sin \delta \\ 50\% \text{ of } 796\text{MW} &= \frac{95\%230\text{kV} \times 105\%230\text{kV}}{X_L} \sin 10^\circ \\ &\Rightarrow X_L = 23\Omega \end{aligned}$$

Figure 25.15 shows that with only one module activated, the line reactance can be compensated to 24Ω . The real power flow and reactive powers are:

$$\begin{aligned} P &= \frac{V_T \times V_R}{X_L} \sin \delta \\ &= \frac{218.5\text{kV} \times 241.5\text{kV}}{24\Omega} \sin 10^\circ \\ &= 381.8\text{MW} \end{aligned}$$

The sending end reactive power is

$$\begin{aligned} Q_s &= V_S \times \frac{V_S - V_T \cos \delta}{X_L} \\ &= 218.5\text{kV} \times \frac{218.5\text{kV} - 241.5\text{kV} \times \cos 10^\circ}{24\Omega} = -176\text{MVar} \end{aligned}$$

The terminal end reactive power is

$$Q_T = V_T \frac{V_S \cos \delta - V_T}{X_L}$$

$$= 241.5\text{kV} \times \frac{218.5\text{kV} \times \cos 10^\circ - 241.5\text{kV}}{24\Omega} = -264.8\text{MVar}$$

The line reactive power is given by $Q_S - Q_T = -176\text{MVar} + 264.8\text{MVar} = 88.8\text{MVar}$.

The current is

$$I = I \cos \phi + jI \sin \phi = I \times e^{j\phi}$$

$$I \sin \phi = \frac{V_S \cos \delta - V_T}{X_L} = \frac{Q_T}{V_T} \qquad I \cos \phi = \frac{V_S \sin \delta}{X_L} = \frac{P}{V_T}$$

$$= \frac{218.5\text{kV} \times \cos 10^\circ - 241.5\text{kV}}{24\Omega} \qquad = \frac{218.5\text{kV} \times \sin 10^\circ}{24\Omega}$$

$$= -1.10\text{kA} \qquad = 1.58\text{kA}$$

$$I = -1100 + j1581 = 1926^{-j55.2^\circ} \text{ pu wrt } V_T$$

The line reactive power can be calculated and confirmed from $I^2 X_L = 1926^2 \times 24\Omega = 89.0\text{MVar}$

The sending power factor is

$$P = \sqrt{3} V_S I_L \cos \phi$$

$$= \sqrt{3} \times 218.5\text{kV} \times 1.926\text{kA} \times \cos 52.5^\circ$$

$$= 443.7\text{MW}$$

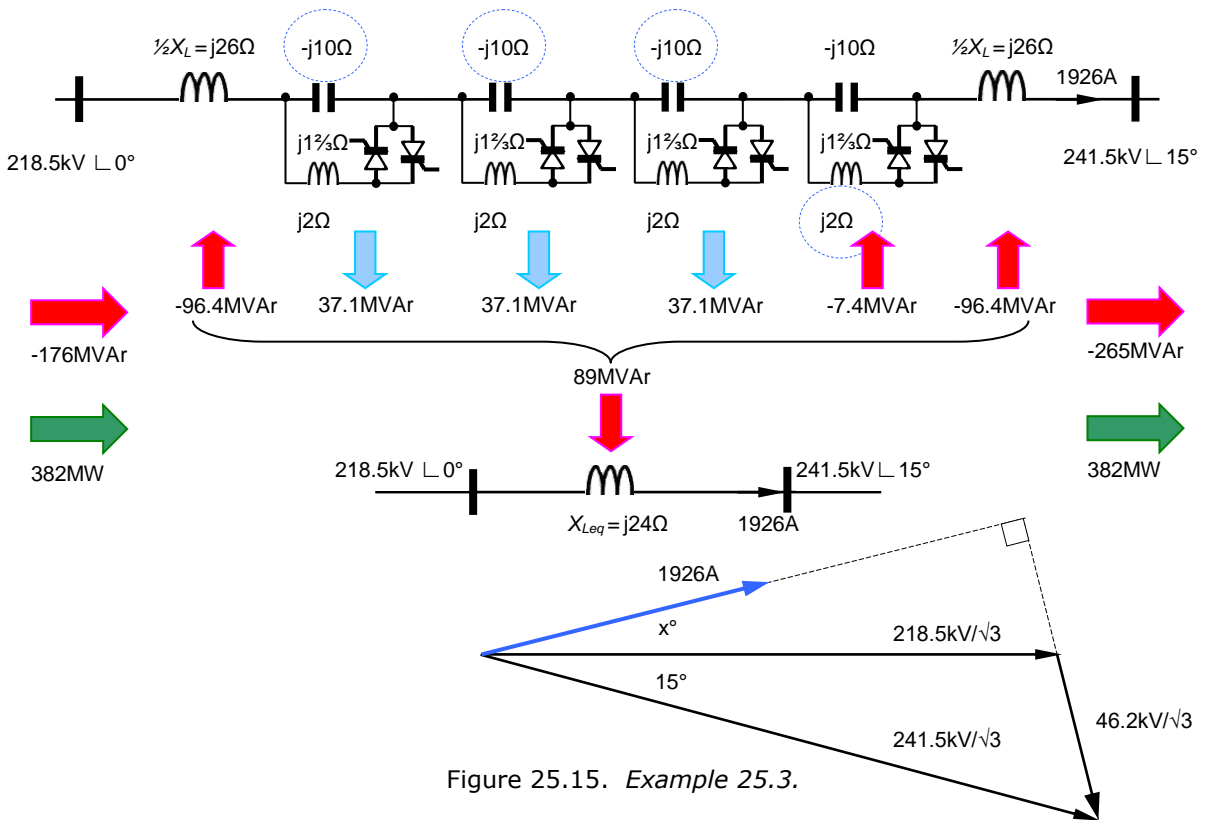

Figure 25.15. Example 25.3.

Example 25.4: Series thyristor controlled reactor specification – Vernier control

A 50Hz 400V ac transmission line has line reactance of $X_L = 2.2 \Omega$ and is delivering 100kW at a load angle of 80° . The TCSC comprising $C=30\mu\text{F}$ and $L=3.53\text{mH}$ is operated at a load angle of 80° . Calculate

- i. the degree of compensation k
- ii. the compensating capacitive reactance
- iii. the line current I
- iv. the reactive power Q
- v. the TCSC delay angle if the effective capacitive reactance is 200Ω

Solution

i. From equation (25.44)

$$k = 1 - \frac{V^2}{X_L P_{sc}} \sin \delta = 1 - \frac{400^2}{2.2\Omega \times 100\text{kW}} \times \sin 80^\circ = 0.284$$

ii. From equation (25.43), the compensation reactance is

$$X_{sc} = kX_L = 0.284 \times 2.2\Omega = 0.624\Omega$$

iii. From equation (25.44)

$$\mathbf{I} = \frac{2V}{X_L(1-k)} \sin \frac{1}{2}\delta = \frac{2 \times 400\text{V}}{2.2\Omega \times (1-0.284)} \sin \frac{1}{2}80^\circ = 326.5\text{A}$$

iv. From equation (25.44)

$$Q_{sc} = \frac{2V^2}{X_L} \times \frac{k}{(1-k)^2} (1 - \cos \delta) = \frac{2 \times 400^2}{2.2\Omega} \times \frac{0.284}{(1-0.284)^2} \times (1 - \cos 80^\circ) = 66,586 \text{ VAR}$$

v. The compensator capacitive reactance is

$$X_c = \frac{1}{\omega C} = \frac{1}{2\pi f C} = \frac{1}{2\pi 50\text{Hz} \times 30\mu\text{F}} = 106.1\Omega$$

The compensator inductive reactance is

$$X_L = \omega L = 2\pi f L = 2\pi 50\text{Hz} \times 3.53\text{mH} = 1.11\Omega$$

From equations (25.51) and (25.52)

$$X_{eff}(\alpha) = \frac{X_c X_{L1}(\alpha)}{-X_c + X_{L1}(\alpha)}$$

$$200\Omega = \frac{106.1\Omega \times X_{L1}(\alpha)}{-106.1\Omega + X_{L1}(\alpha)} \Rightarrow X_{L1}(\alpha) = 32.0\Omega$$

Then

$$X_{L1}(\alpha) = \frac{\frac{1}{2}\pi}{\frac{1}{2}\sin 2\alpha + \pi - \alpha} X_L$$

$$32.0\Omega = \frac{\frac{1}{2}\pi}{\frac{1}{2}\sin 2\alpha + \pi - \alpha} \times 1.11\Omega \Rightarrow \alpha = 167^\circ$$

♣

25.8.4 Static series phase angle reactive power compensation/shift SPS

Phase compensation is a specific case of series compensation, as shown in figure 25.16, where the phase angle change is used to control the power flow. Where as series reactive control is usually located at the line reactance midpoint, phase angle compensation is performed at the sending end of the transmission line. The compensator is an ac voltage source V_ϵ of controllable magnitude and phase angle. The effecting sending end voltage $V_{S\text{eff}}$ becomes

$$V_{S\text{eff}} = V_S + V_\epsilon \quad (25.58)$$

The compensator can function in one of two ways.

- The load angle is varied maintaining a voltage magnitude $V_{S\text{eff}}$ the same as the sending voltage V_S

$$|V_{S\text{eff}}| = |V_S| = V_{S\text{eff}} = V_S = V \quad (25.59)$$

- The compensator phase angle is maintained at quadrature to the sending voltage

$$|V_{S\text{eff}}| = V_{S\text{eff}} = \sqrt{V_S^2 + V_\epsilon^2} \quad (25.60)$$

In both cases, power flow control is achieved at the expense of consuming reactive power from the network. The system transfer admittance has V_S replaced by $V_{S\text{eff}}$, that is

$$\begin{bmatrix} I_{S\text{eff}} \\ I_T \end{bmatrix} = \frac{1}{X_L} \begin{bmatrix} 1 & \cos \phi + j \sin \phi \\ -(\cos \phi - j \sin \phi) & 1 \end{bmatrix} \begin{bmatrix} V_{S\text{eff}} \\ V_T \end{bmatrix} \quad (25.61)$$

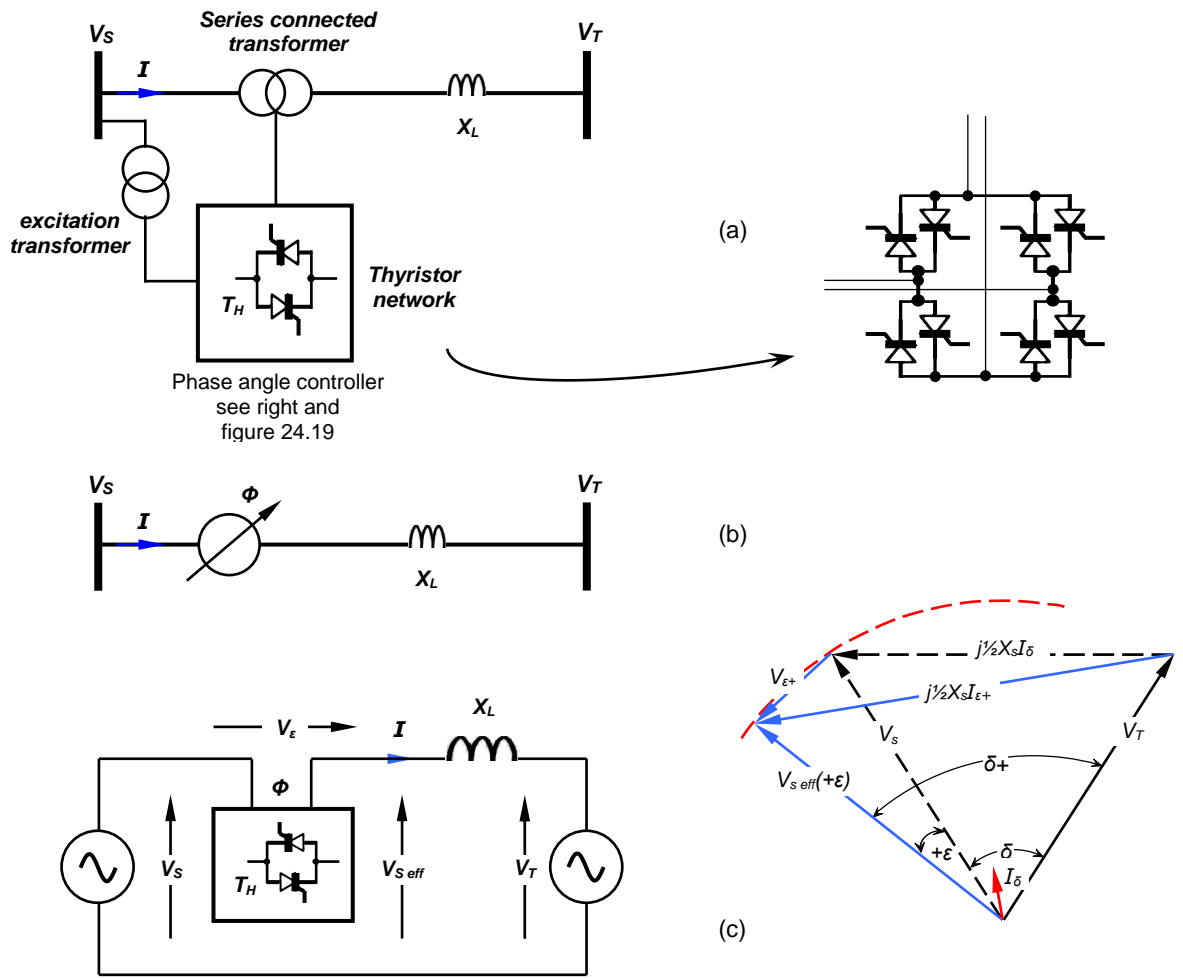

Figure 25.16. Transformer series phase angle compensation: (a) series transformer with ac tap changing thyristor network; (b) variable phase angle representation; and (c) two port series phase angle compensator system.

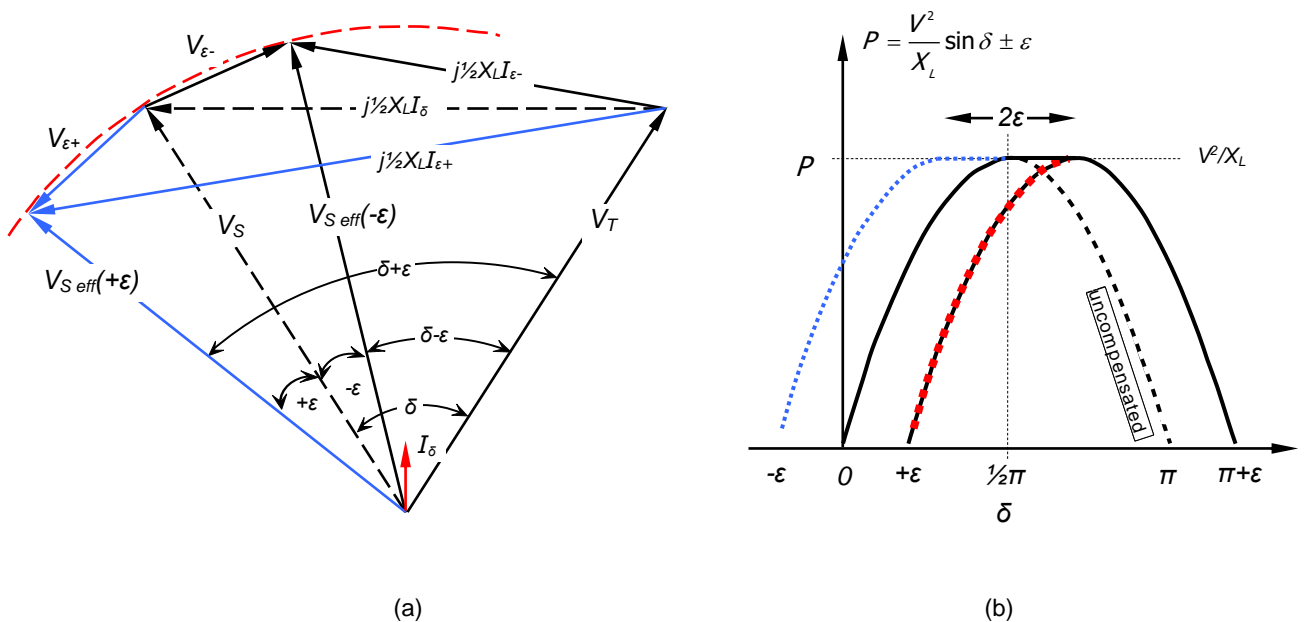

Figure 25.17. Transformer series phase angle compensation: (a) phasor diagram for phase shift $\pm\epsilon$ and (b) transmission power versus load angle.

Phase shifting ($\Phi < \frac{1}{2}\pi$) with a constant voltage magnitude $|V_{S\text{eff}}| = |V_S|$

Figure 25.17a shows the resultant phasor diagram for the effects of a series phase compensator when the regulator output voltage magnitude is the same as the sending voltage magnitude. Figure 25.17b shows that the effect of the phase shift is to shift the power transmission dependence on load angle. Since $|V_{S\text{eff}}| = |V_S| = |V_T| = V$, the active power transferred through the phase shifter is

$$P_{S-T}^{comp} = \frac{|V_s||V_T|}{X_L} \sin(\delta - \epsilon) = \frac{V^2}{X_L} \sin(\delta - \epsilon) \tag{25.62}$$

By controlling the compensator angle ϵ , the output power can be controlled independent of the transmission load angle δ . The peak power can be shifted from a load angle $\delta = \frac{1}{2}\pi$ to any desired load angle, by maintaining the phase shifter angle such that $\delta - \epsilon = \frac{1}{2}\pi$ is maintained. If $\delta < \frac{1}{2}\pi$, the phase shift 'polarity' can be reversed to give a net angle of $\frac{1}{2}\pi$ for maximum power. The transmitted reactive power is

$$Q_{comp} = \frac{2V^2}{X_L} (1 - \cos(\delta - \epsilon)) \tag{25.63}$$

Equations (25.62) and (25.63) show that

- The maximum power and VAR are unchanged, only the load angle at which they occur can be controlled.
- Unlike other series and shunt compensators, the phase compensator needs to handle both real power and VAR.

From the phasor diagram in figure 25.17a, the shift compensator terminal voltage and current are

$$\begin{aligned} V_\epsilon &= 2V \sin \frac{1}{2}\epsilon \\ I &= \frac{2V}{X_L} \sin \frac{1}{2}\delta \end{aligned} \tag{25.64}$$

The apparent power of the compensator is therefore

$$S_{comp} = V_\epsilon I = \frac{4V^2}{X_L} \sin \frac{1}{2}\epsilon \sin \frac{1}{2}\delta \tag{25.65}$$

If the compensation angle is negative, by effectively reversing the terminals of the compensator, then maximum power can be attained for load angles of less than $\frac{1}{2}\pi$, as indicated by the dashed sine curve portion in figure 25.17b.

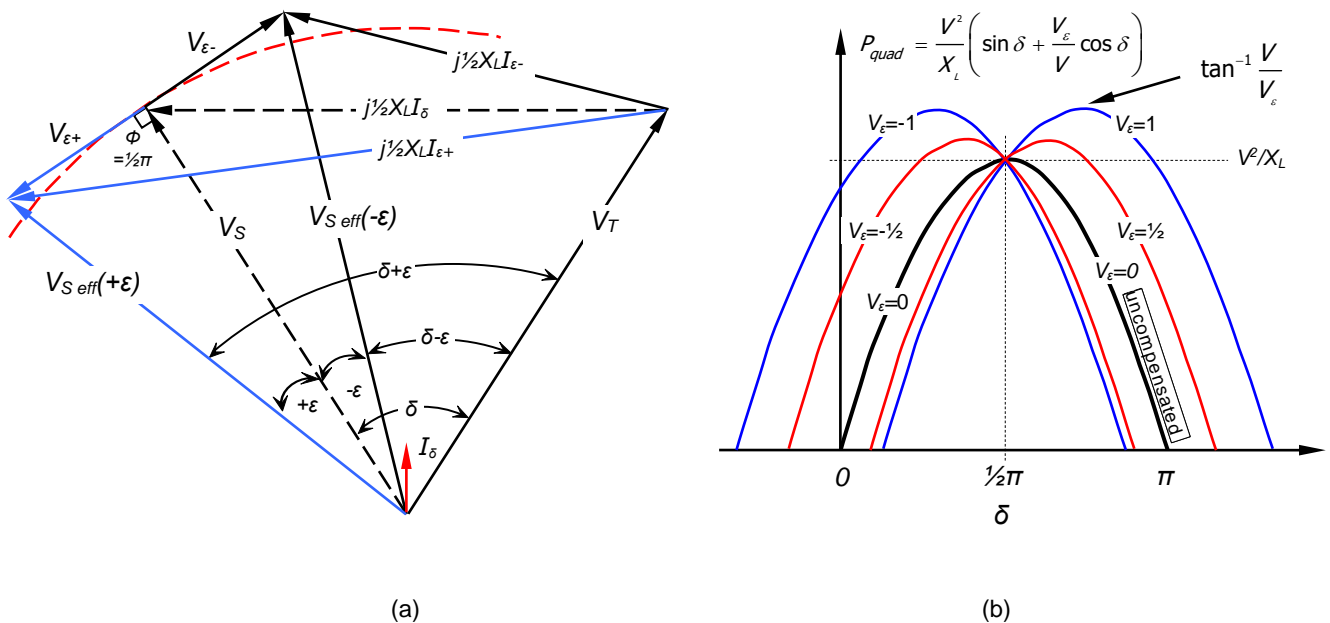

Figure 25.18. Series phase angle compensation: (a) phasor diagram for phase shift $\pm\epsilon$ giving quadrature boosting, $\Phi = \frac{1}{2}\pi$ and (b) transmission power versus load angle.

Phase shifting with a quadrature phase shift voltage $\sqrt{V_s^2 + V_\epsilon^2}$

Figure 25.18a shows the phasor diagram when the phase shift voltage V_ϵ is maintained at quadrature to the sending end voltage V_s , such that

$$|V_{s\text{eff}}| = V_{s\text{eff}} = \sqrt{V_s^2 + V_\epsilon^2}$$

The power transmitted is show in figure 25.18b and is given by

$$P_{quad} = \frac{V^2}{X_L} \left(\sin \delta + \frac{V_\epsilon}{V} \cos \delta \right) \tag{25.66}$$

The effective transmission end voltage is increased, hence the possible transmitted power is increased. This increased power mode of phase shift compensation is called quadrature boost.

The Quadrature Boost phase shift compensator

The phase shifting configuration shown in figure 25.19a uses a delta connect line transformer to feed a naturally commutating thyristor tap changing circuit which transfers power to the line through the series line transformer. The transformer phase arrangement ensures that the series injected voltage is always at quadrature to the line voltage. Since the effective line voltage $V_{s\text{eff}}$ is now greater than the line sending voltage V_s , as shown in the phasor diagram in figure 25.19b, the converter forms a quadrature boost compensator. The tap changer is not reversible, that is, power can only flow from the shunt excitation transformer to the series compensating transformer in the transmission line.

The series compensator can be controlled in two ways

- Phase angle control of the thyristors in one bridge
- Fewer harmonics are generated by either switching in or out the different excitation windings shown in figure 25.19a, which gives 27 different output voltage possibilities.

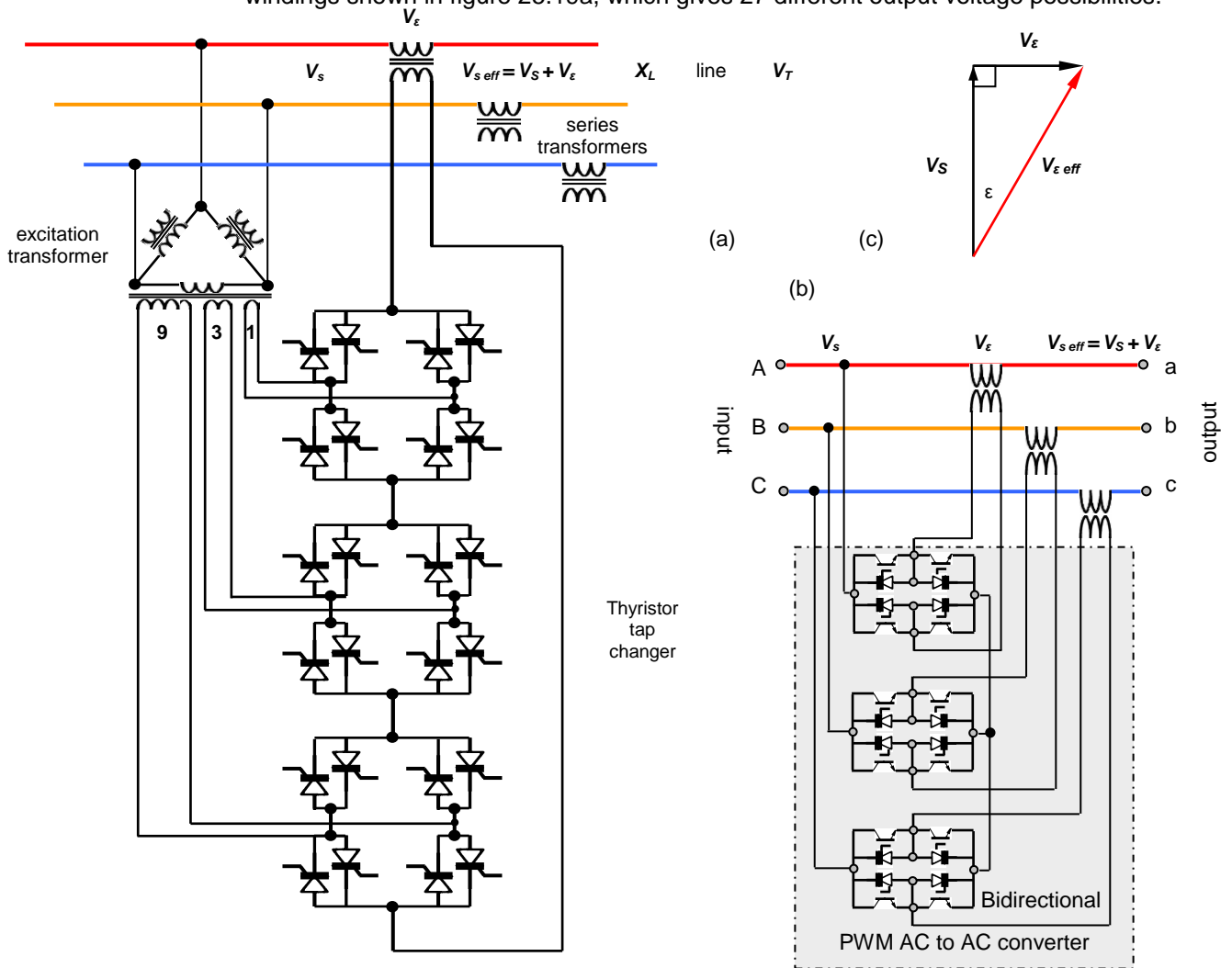

Figure 25.19. Series phase angle compensator with quadrature boosting: (a) thyristor transformer tap changer; (b) bidirectional PWM ac to ac converter; and (c) phasor diagram for phase shift $\pm\epsilon$ giving quadrature boosting, $\Phi=1/2\pi$.

Continuous Voltage Regulators, CVR

AC/AC Continuous Voltage Regulators (CVR) or PWM (or self commutated) AC voltage controllers (or stabilizers), are fast and tolerant power-electronics arrangements without moving parts and with no need for tap changing. The AC choppers are realized on the basis of single fully bidirectional switches with turnoff capability, thus the CVR topology in Figure 25.19c, with bipolar PWM, allows bipolar regulation of the phase output voltage.

25.9 Self commutating FACTS devices - custom power

Reactive power compensators are essential transmission system devices used for voltage regulation, stability enhancement, and for increasing power transfer. FACTS devices are aimed at the transmission level, while compensators at the distribution level are term custom power controllers. FACTS compensators are based on the more robust (but slower responding) thyristor natural (or line) commutation technology. Custom power, as shown in figure 25.20 for single-phase compensators, although possibly operating on the same principles as FACTS devices, is based on less robust (but faster responding) self commutation devices (GCThyristor and IGBT), hence tends to be associated with the lower voltages of the distribution system, where more sensitive equipment and embedded, distributed generation may be connected.

Traditionally the mature technology of passive harmonic notch and low pass L-C based filters were used to control harmonic pollution and switched capacitor banks were used for power factor correction. FACTS transmission level devices considered, based on natural commutated thyristor configurations, include the TSC, TCR, etc. Custom power distribution level devices to be considered are static synchronous compensators, which include the dynamic voltage restorer - DVR, shunt compensator - STATCOM, and the unified power flow controller - UPFC. They are based on GCThyristor or IGBT PWM inverter/converter bridge topologies which use a large reactive dc link, intermediate energy source (a dc-side capacitor or a dc-side inductor). The topologies are commonly called active filters even though they can compensate for reactive and active power (at the fundamental frequency 50/60Hz) as well as perform harmonic filtering functions (at multiples of the fundamental frequency).

Active (self-commutating GCThyristor and IGBT) inverter based topologies provide compensation for

- Voltage and current harmonics
- Reactive power
- Neutral current
- Unbalanced loads
- Unbalanced phase voltages

The PWM inverter approach adopted can be

- Inductive dc-link, current source PWM inverter, CSI, which acts as a controllable sinusoidal current source to compensate for non-linear load harmonics
 - requires ac output shunt capacitance to filter current harmonics from the generated square-wave current waveform
 - self-supporting, large dc-link reactor
 - high reliability
- Capacitive dc-link, voltage source PWM inverter, VSI, which acts as a controllable sinusoidal voltage source
 - requires output series inductance to filter voltage harmonics from the generated square-wave voltage waveform
 - self-supporting, large dc-link capacitor
 - applicable to multilevel inverter topologies for better system voltage matching

The CSI or VSI inverter based compensators can be connected to the system, usually through voltage matching transformers (where in the case of the VSI, the transformer leakage inductance may provide voltage output harmonic filtering), in any of three ways, as shown in figure 25.20a.

- Series inverter compensator – called a dynamic voltage restorer, DVR – compensating for
 - Line voltage harmonics
 - Spikes, notches and sags and swells
 - Balance and regulate load or line terminal voltage
 - Static VAR generator to stabilise and improve voltage profile
- Shunt inverter compensator – called a STATCOM – compensating for
 - Line current harmonics
 - Reactive power compensation
 - Balancing of three-phase loads

- Series plus shunt inverters/converters – called a unified power flow controller, UPFC
 - Performs the functions of both the shunt and series compensators
 - Two inverters share a common dc current or voltage link

Each of these three compensators belong to the generic family of static synchronous compensators.

The classification matrix for custom power devices is shown in figure 25.20. For ease of comparison and understanding, single-phase versions are show, with specific three-phase configurations considered in the sections to follow. Three-wire (floating neutral) and four-wire (connected neutral) PWM inverter topologies are extensions to the basic single-phase topologies considered.

Given the switching frequency limitations of 6.5kV IGBT and IGCThyristor technology (<1 kHz), synchronous selective harmonic elimination SHE is used for switching modulation rather than standard PWM or SVM. If transformer coupling is adopted, low-voltage IGBTs (3.3kV) allow a higher switching frequency (2.5kHz). The trade-off is that the transformer core must transmit with minimal attenuation, the highest required compensation harmonic. Thinner transformer laminations (0.1mm and 0.05mm, as opposed to 0.3mm for 50/60Hz) allow a higher operating frequency, but at the expense of reduced flux density and higher core losses/kg. The best trade-off is 0.1 mm lamination thickness compensating for harmonics up to and including the 17th and 19th. Higher harmonics (the 23rd, 25th and higher – implying a switching frequency greater than 2kHz) are more effectively attenuated with passive L-C notch (with long term drift problems) and low pass filters. When only harmonic distortion correction is required, as opposed to any 50/60Hz VAr compensation, nano-crystal amorphous core materials are an effective alternative the silicon grain orientated steels.

25.9.1 - Static synchronous series compensator (SSSC) or Dynamic Voltage Restorer - DVR

The static synchronous series compensator (is a dynamic voltage restorer without active power transfer) is a transformer coupled, PWM voltage source inverter that functions in series with the distribution line as shown in figure 25.21. Theoretically, it draws no power from the line since it uses a capacitor on its dc link which provides only reactive power. This makes the DVR a versatile regulating compensator. In steady-state it functions as a series phase shifter SPS, injecting a variable magnitude and angle voltage at one line end in order to control both the active and reactive power flow. The phase angle (which controls the real power if a suitable bidirectional dc-link source exists) is controllable between 0 and 2π , as shown in the phasor diagram in figure 25.21c. The magnitude of V_{DVR} is controlled by the inverter PWM modulation depth. As well as being a series phase shifter, SPS, it also functions as a variable series impedance compensator.

Generally, from figure 25.21a

$$\begin{aligned} V_{DVR} &= V_r - V_s \\ &= |V_{DVR}|(\cos \varphi + j \sin \varphi) = V_d + jV_q \end{aligned} \quad (25.67)$$

If the DVR does not involve any active power source and the only real power drawn from the ac line is that necessary to maintain the capacitor voltage so as to compensate for inverter and coupling transformer power losses, then $V_d = 0$ and V_q is in quadrature to the compensator/line current. By varying the magnitude of V_q , the DVR performs the function of a variable reactance compensator, where

$$\begin{aligned} V_d &\approx 0 \\ \text{if } \begin{cases} V_q > 0 \text{ the DVR is capacitive} \\ V_q < 0 \text{ the DVR is inductive} \end{cases} & \end{aligned} \quad (25.68)$$

Within its energy limits, the DVR is suited for dynamically compensating any line feeding sensitive or critical equipment for

- voltage harmonics
- power factor correction

and for a short duration

- voltage sags and swells
- voltage imbalances
- outages

In the standby mode, the output voltage is zero and the inverter losses are low since no switching occurs. By turning on all the upper (or lower but not both) switches in the VSI inverter, the three single-phase transformers and inverter are seen in the line as a short circuit (as for a current transformer). Given transformers are necessary, voltage matching of the VSI devices facilitates the use of 3.3kV IGBT technology that allow modulation frequencies above 2kHz, which is necessary for active filtering.

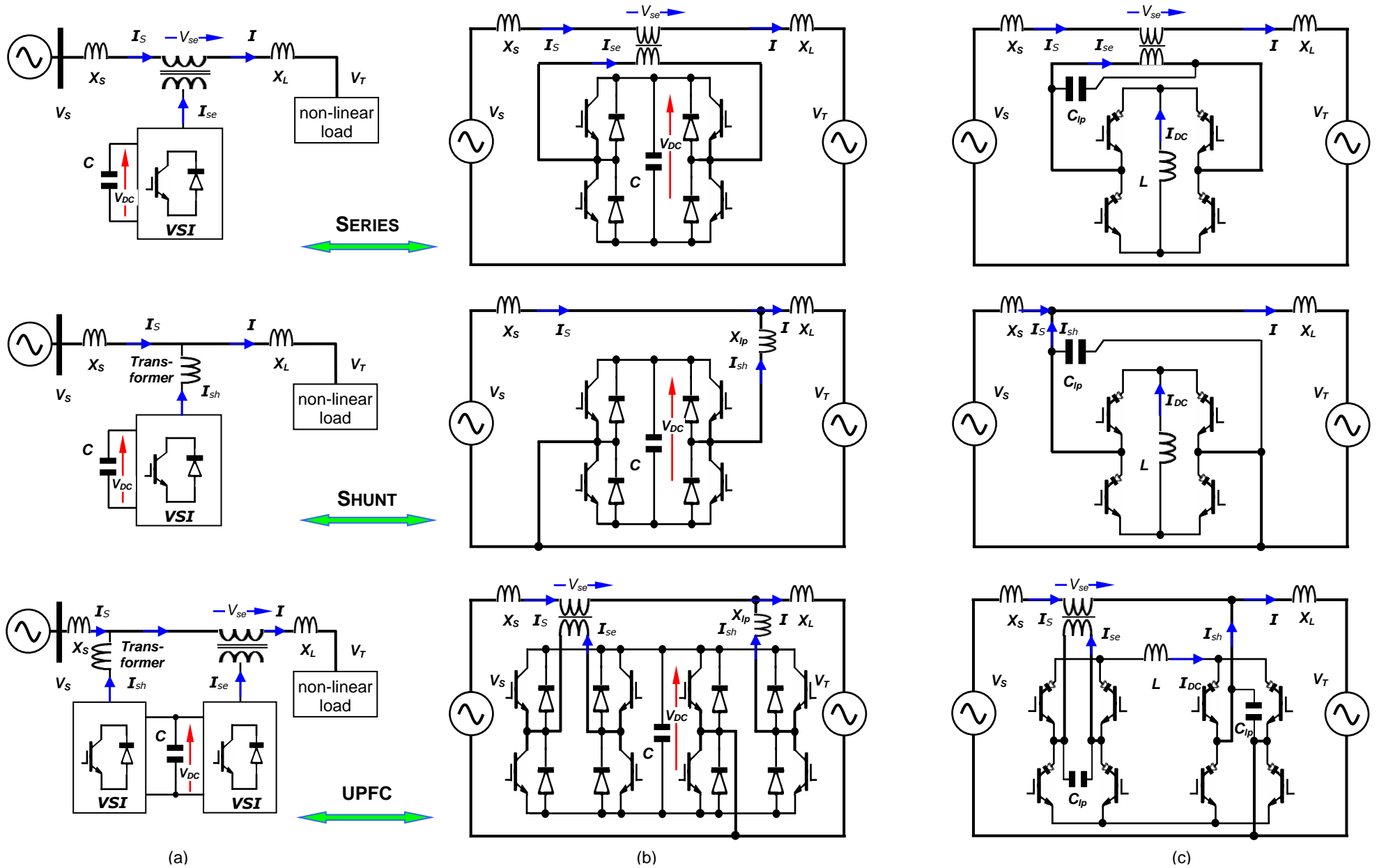

Figure 25.20. Static synchronous compensator family: (a) transmission schematic of voltage source compensators (as power filters) transformer coupled to the ac network; (b) single-phase static synchronous compensators using dc-link capacitor voltage sources; and (c) static synchronous compensators using dc-link inductor current sources.

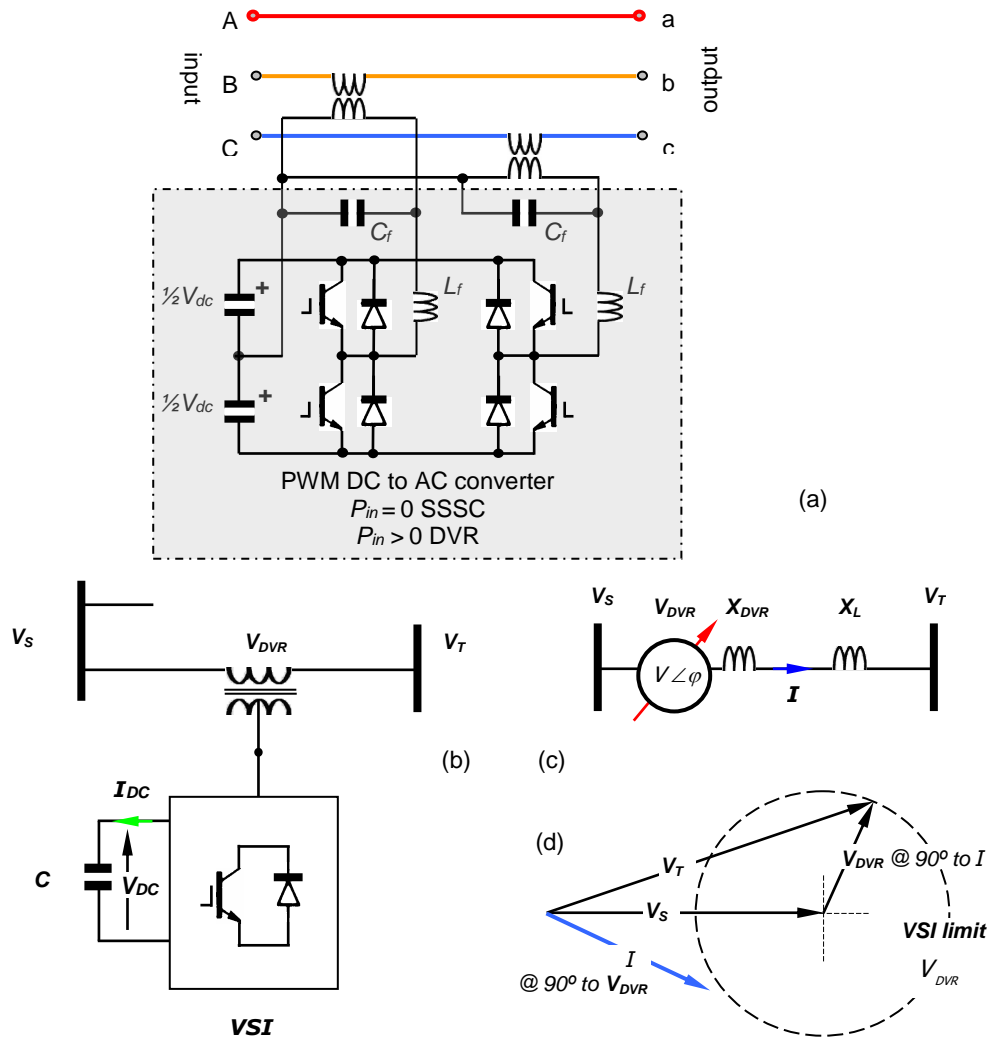

Figure 25.21. *Static synchronous series compensator (or dynamic voltage restorer DVR): (a) schematic and (b) block diagram of a voltage source inverter, transformer coupled in series with the ac network; (c) series connected DVR shown as a variable magnitude and phase angle voltage source SSSC; and (d) 50/60Hz operating phasor diagram of SSSC, where V_{DVR} is always perpendicular to the line current, I .*

Specific single-phase transformer coupling can be avoided if the DVR is connected at the opened star point of the main ac supply Y configured transformer or autotransformer. Alternatively, access to the transformer star point allows the use of a three-phase autotransformer rather than three single-phase transformers. A CSI is well suited for series application (with an outer voltage loop) since it is normally operated with the switches in an on-state, thereby ensuring that the DVR is seen as a short-circuit in the standby/fault mode.

Voltage harmonic cancellation

Each of the three source voltages can be expressed in terms of a fundamental frequency phase voltage and its harmonics. Inserting appropriate voltages can compensate for voltage harmonics associated with the terminal supply voltages under balanced or unbalanced conditions in three wire systems. Consider the ac network per phase configuration of a series active filter compensating the voltage harmonic load shown in figure 25.21c. The non-linear series load equivalent voltage source is V_T and X_L (Z_L) is the non-linear load impedance. G is the transfer function, which has no fundamental component, of the control reference for the active series filter to compensate for the load voltage harmonics seen at the source.

The series compensating voltage, with gain k , is

$$I_{sh} = k G I_T$$

Also

$$I_s = \frac{V_s - V_T}{Z_{DVR} + Z_L + kG}$$

In satisfying the harmonic requirements

$$k \gg 1$$

Then by Kirchhoff's voltage law

$$V_{DVR} \approx V_{S-harm} - V_{T-harm}$$

$$I_S \approx 0$$

If

$$|1 - G|_{harm} \ll 1$$

then

$$I_{S-harm} = -(1 - G)V_{T-harm} \approx 0$$

This implies that Z_L and Z_{DVR} (and the source reactance) do not affect the performance of the series active filter.

Series voltage regulation

The terminal voltage V_T in figure 25.22a draws a lagging current I_T and the series compensator V_{DVR} is to maintain the load voltage V_T constant, but at any angle with respect to V_S . From Kirchhoff's voltage law

$$V_S = jI_T X_R + V_{DVR} + V_T \tag{25.69}$$

The series compensator can deliver any voltage up to a maximum V_{DVR} , as shown by the circle outer locus with centre O for the series regulator in figure 25.22b. If V_T is held constant then the source V_S can have a magnitude and angle that lies anywhere within the circle. If V_T sags and swells (changes length) then provided the variation is within the circle, V_{DVR} can compensate to maintain a constant voltage V_S .

Maximum and minimum voltage compensation needed from V_{DVR} occurs when the source V_S forms a tangent to the circle as shown in figure 25.22c. In each case the current is not in phase with the compensation voltage, hence the compensating converter must transfer real power. The effective sending voltage $V_{S\text{ eff}}$ is phasor N-O. The phasor O-W represents the case when power is delivered from the compensator in an effort to compensate for the sagging (reduced) V_T voltage phasor N-W, while the phasor O-X represents the case when V_T has swelled to phasor N-X and power is drawn by the compensating converter whilst attempting to decrease the line voltage. The inverter in figure 25.21a creating V_{DVR} must have a bidirectional dc voltage supply maintaining the dc-link voltage.

The converter dc-link voltage can be self-supporting if no energy is lost or gained by the dc-link when the line current is at quadrature to the compensator voltage, as shown in figure 25.22d. In this case, the source voltage V_T can be compensated when its voltage phasor lies along the line W-O-X. The magnitude range of the voltage V_T that can be compensated, is reduced. The range is reduced from phasor N-W to phasor N-X in figure 25.22c when converter power can be transferred, and to between N-Y to N-Z when only reactive energy can be transferred by the compensating converter, as in figure 25.22d.

The series compensation is effective for a wide range of line impedances, including low impedance stiff feeders, provided the line impedance phasor is within the compensating circle. The basic series converter arrangement can also be used for voltage distortion compensation.

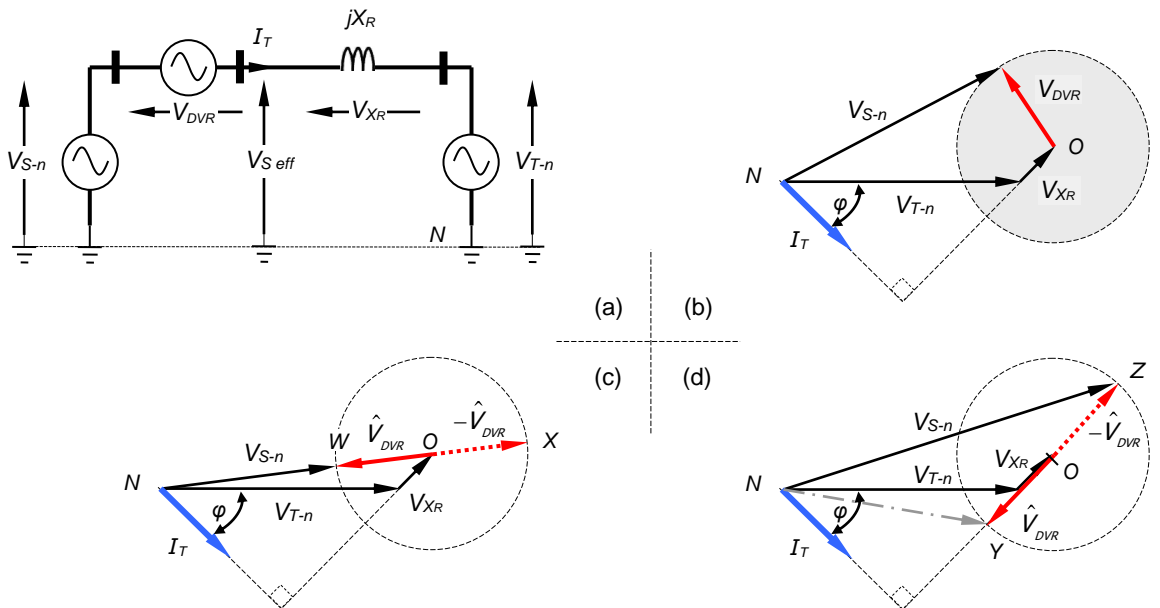

Figure 25.22. Static series voltage compensation: (a) series compensated network; (b) general series voltage compensation; (c) voltage sag and swell real-power compensation; and (d) quadrature reactive-power series voltage compensation.

The phasor diagrams in figure 25.23 show the series compensator operating in three different modes, namely, capacitive and inductive compensation and in a mode of reversing the power flow. The effective sending voltage $V_{S\text{ eff}}$ is shown as a dashed line in each case. Series line resistance has been incorporated, giving the voltage phasor V_R in phase with the current in the parts of figure 25.23. The line voltage drop, V_{line} is therefore the line impedance voltage drop.

Capacitive compensation

SSSC capacitive compensation is shown in figure 25.23a. The phasor quadrature voltage V_{DVR} is in the opposite direction of the phasor V_{XR} and V_{DVR} lags the current phasor I by 90° . For the same line total voltage drop V_{line} , the voltage phasor associated with the line reactance V_{XR} increases and results in a transmission line current increase.

Inductive compensation

Inductive compensation is shown by the phasor diagram in figure 25.23b. The quadrature voltage is in the same direction as the phasor V_{XR} and V_{DVR} leads the current phasor I by 90° . For a constant V_{line} , the phasor V_{XR} decreases. The transmission line current reduces and results in reduced power flow.

Reverse power flow

The ability of an SSSC to reverse power flow is illustrated by the phasor diagram in figure 25.23c. Operation is similar to inductive compensation but the VSC voltage is increased until larger in magnitude than V_{XR} . For a constant V_{line} , V_{XR} reverses direction and the current phasor I reverses, thence power flow is reversed.

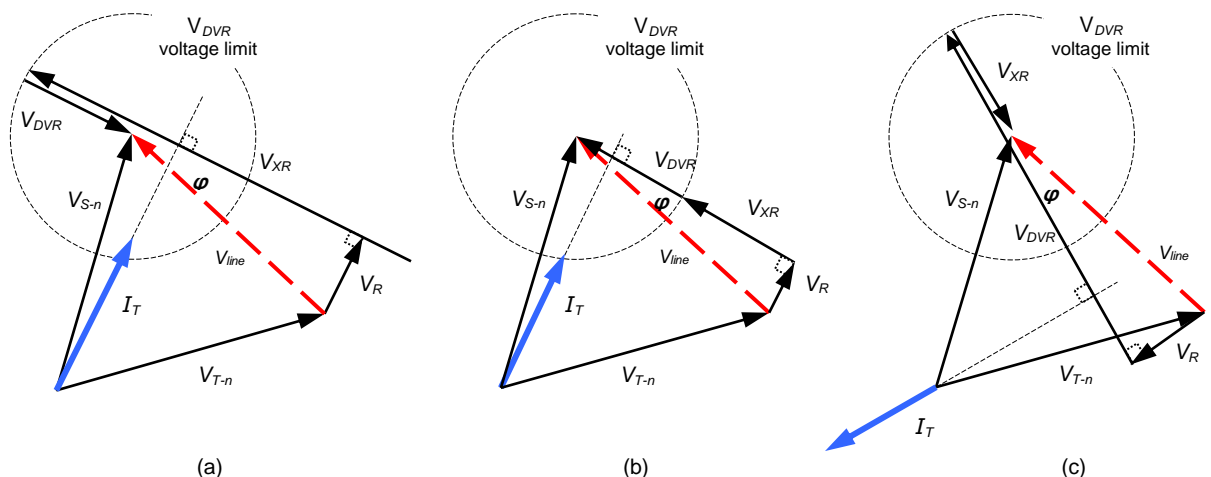

Figure 25.23. Phasor diagrams for the three series compensator modes of operation: (a) capacitive compensation; (b) inductive compensation; and (c) power flow reversal.

25.9.2 - Static synchronous shunt compensator - STATCOM

The STATCOM (**static** synchronous shunt **comp**ensator) is a shunt current compensator comprising a current or voltage source inverter, shunt connected to the ac system through a first order passive filter, as shown in figure 25.24a for a VSI. The dc-side main reactive energy storage element is

- a dc capacitor (voltage source, VSI) in which case the interconnect filter comprises series line inductance for attenuating VSI output voltage harmonics or
- an inductor (current source, CSI) in which case the interconnect filter comprises shunt capacitance for bypassing CSI output current harmonics. Not favoured over the VSI.

No net energy is needed, except to replace the energy dissipated in the inverter and filter components.

The STATCOM function is to

- regulate the line at the point of connection when functioning in a SVC mode and/or
- minimise current harmonics by anti-phase current injection action – as an active filter.

Whilst a current STATCOM based on CSI topologies is feasible, the VSI is the most widely used for practical STATCOM systems. For the VSI based STATCOM, the dc reactive energy storage element is a dc capacitor in which case the interconnect filter comprises series line inductance for attenuating VSI output voltage harmonics. Since the STATCOM does not participate in real power exchange, no net energy is needed, except to replace the energy dissipated in the inverter and filter components.

Figure 25.24b shows the system model, while figure 25.24c shown the simplified VSI circuit. The series voltage harmonic filtering inductance can be the leakage inductance associated with the three single-phase line voltage matching transformers or three auto-transformers. A dc chopper, with a dumping resistor as load, may be used across the dc-link capacitor to limit VSI over-voltage during intermittent transients when the STATCOM acts as an uncontrolled rectifier, created by the VSI freewheel diodes shown in figure 25.24c. The phasor diagram in figure 25.24d, for the line to neutral voltage, is associated with the circuit in figure 25.24b, in conjunction with the power and reactive power equations given by equations (25.6) and (25.8), can be used to explain STATCOM operating principles.

$$P = \frac{V_{sc} V_T}{X_{sc}} \sin(\delta_T - \delta_{sc}) = 0 \tag{25.70}$$

$$Q_{sc} = V_T \times \frac{V_T - V_{sc} \cos(\delta_T - \delta_{sc})}{X_{sc}} = \frac{V_T}{X_{sc}} (V_T - V_{sc}) \tag{25.71}$$

$$I_{sc} = \frac{V_{T-n} - V_{sc-n}}{X_{sc}} \tag{25.72}$$

In steady-state, the inverter output voltage fundamental V_{sc} (which is controlled by the PWM modulation index) is in phase with the ac line voltage V_T ($\delta_{sc} = \delta_T$), while the STATCOM current I_{sc} always leads or lags the line voltage by 90° because of the inductive reactive coupling X_{sc} therefore $\cos(\delta_T - \delta_{sc}) = \cos 0 = 1$. Thus $P \approx 0$ is maintained as given by equation (25.70) when $\sin(\delta_T - \delta_{sc}) = \sin 0 = 0$.

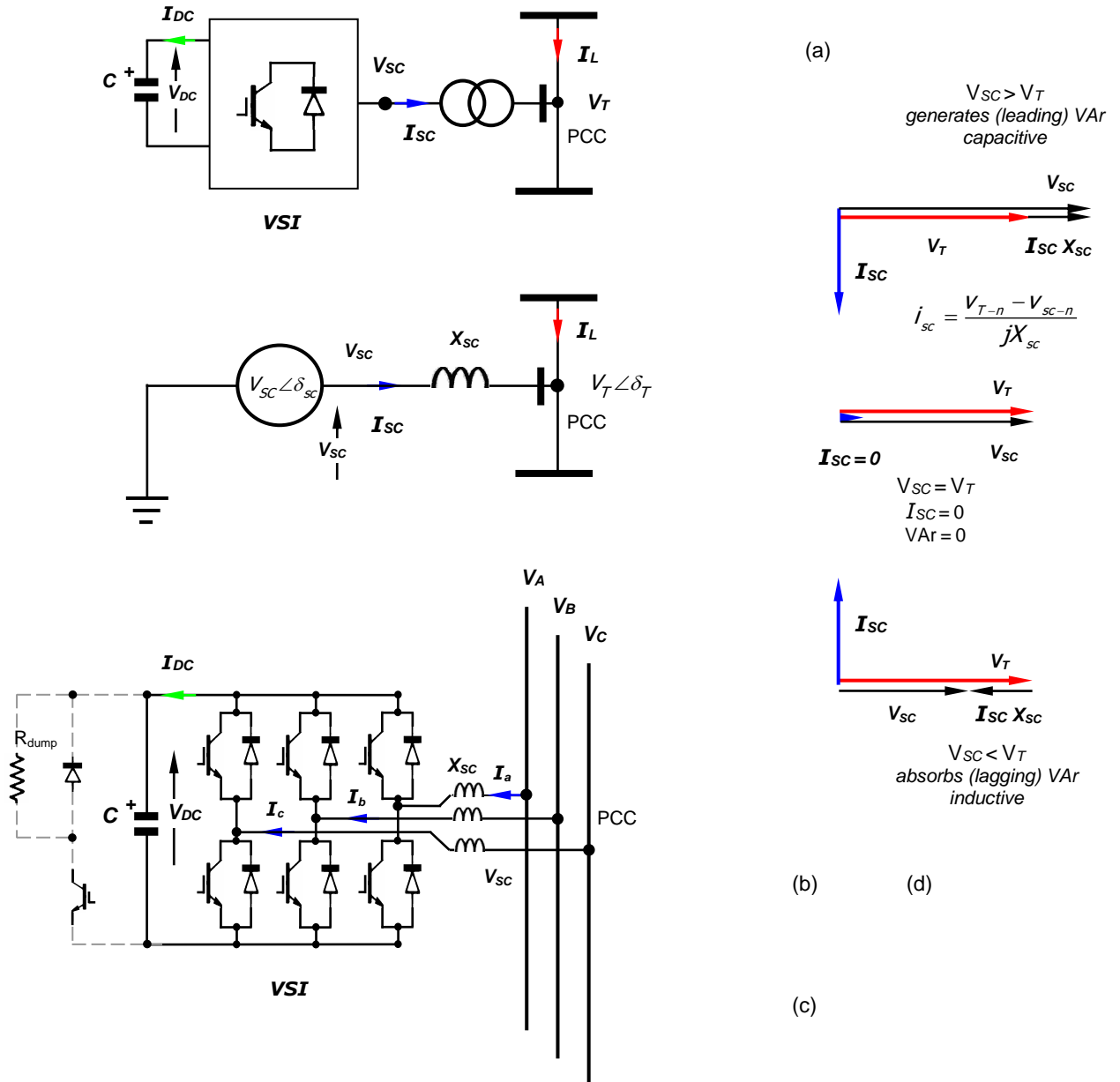

Figure 25.24. Active shunt regulator - STATCOM: (a) a voltage source inverter VSI, inductively shunt connected (transformer coupled) to the ac network; (b) shunt connected STATCOM shown as a variable magnitude and phase angle voltage source; (c) main VSI circuit; and (d) phasor diagrams for leading (upper phasor diagram) and lagging (lower phasor diagram) modes of operation.

From equations (25.70) and (25.71), since $\delta_{SC} = \delta_T$, only reactive power flows and

- when the STATCOM voltage V_{SC} is less than the line voltage V_T ($|V_{SC}| < |V_T|$), reactive power is absorbed (inductive) by the STATCOM, from V_T to V_{SC} (which tends to decrease the point of connection voltage), while
- when the voltage magnitudes are reversed, that is $|V_{SC}| > |V_T|$, the STATCOM generates (capacitive) reactive power (which tends to increase the point of connection voltage).
- When $V_{SC} = V_T$, the voltage V_{SC} across the connecting inductance X_{SC} is zero, so no STATCOM current flows $I_{SC} = 0$.

Thus a STATCOM behaves like a shunt inductor (I lags V) without a physical inductor or magnetic field, and like a shunt capacitor (I leads V) without a physical capacitor or electric field.

When used in a voltage regulation mode (as opposed to a VAr control mode with constant reactive power output) the STATCOM terminal I - V characteristics are as shown in figure 25.10c for the SVC.

The dc link capacitor is initially charged through the VSI freewheel diodes which form an uncontrolled three-phase line rectifier. Subsequently the STATCOM is controlled to self regulate its dc-link voltage, V_{DC} , as follows.

When the fundamental voltage of the STATCOM slightly leads the ac supply voltage, V_{SC} leads V_T , the capacitor voltage decreases resulting in $V_{SC} < V_T$, real power is transferred from the dc link to the ac line and reactive power is absorbed by the STATCOM – lagging power mode.

When the STATCOM fundamental voltage slightly lags the ac supply voltage, the capacitor voltage increases, $V_{SC} > V_T$, real power is transferred from the ac line to the dc link and reactive power is generated by the STATCOM – leading power mode.

Thus the STATCOM fundamental magnitude V_{SC} controls the reactive power, while the phase angle between the STATCOM and the ac line, $\delta_T - \delta_{SC}$, controls real power flow. In practice, when V_{SC} slightly lags V_T (δ_{SC} lags δ_T), the capacitor voltage V_{DC} is maintained whilst catering for system inverter and transformer power losses. In this way, no separate dc power supply is needed to maintain the dc-link capacitor voltage.

Notice that the dc-link voltage will always be at least the rectified ac grid voltage due to the (uncontrolled) rectification action through the six inverter bridge freewheel diodes.

Although practical limits exist on the magnitude of V_{SC} , the STATCOM power load angle δ_{SC} is continuously adjustable between 0 and 2π , but operates near the line phase angle δ_T in order to minimize real power transfer.

The SATCOM can generate more reactive power during a fault than the SVC since

- from equation (25.42), SVC capacitive reactance power decreases proportionally to voltage V_M while
- from equation (25.71), STATCOM capacitive reactive power decreases linearly with voltage V_{SC} .

Shunt voltage regulation

The terminal voltage V_T in figure 25.25a draws a lagging current I_T and the shunt compensator V_{sh} is to maintain the load voltage V_T constant, but at any angle with respect to V_S . From Kirchhoff's voltage law for the right hand loop in figure 25.25a,

$$V_T = jI_{sh}X_{sh} + V_{sh-n} \quad (25.73)$$

The shunt compensator can deliver any current from zero up to a converter maximum I_{sh} , giving, for a fixed compensation reactance X_{sh} , the circle outer locus with centre O as shown in figure 25.25b. Thus a small change in the magnitude and phase of V_{sh} will cause the shunt reactance voltage to rotate through 360° . From Kirchhoff's current law, the shunt regulator point of common coupling, PCC, yields

$$I_S = I_{sh} + I_T \quad (25.74)$$

These currents are shown in figure 25.25b. The outer voltage loop in figure 25.25a gives

$$V_{S-n} = jI_S X_R + V_{T-n} \quad (25.75)$$

Substituting equation (25.74) gives

$$\begin{aligned} V_{S-n} &= j(I_T + I_{sh})X_R + V_{T-n} \\ &= \{V_{T-n} + jI_T X_R\} + jI_{sh}X_R \end{aligned} \quad (25.76)$$

Since the load network V_T in conjunction with the load network current I_T specify the load power factor, the phasor N-O, $\{V_{T-n} + jI_T X_R\}$ in figure 25.25c is fixed. Because I_{sh} can be varied between zero and I_{sh} , phasor V_{S-n} can lie anywhere within the circle shown in figure 25.25c and not affect the load network V_T . In figure 25.25c, the shunt regulator is delivering real power into the load network since the shunt compensating network PCC voltage V_{T-n} and shunt current (angle given by phasor O-W in figure 25.25c) are not at quadrature.

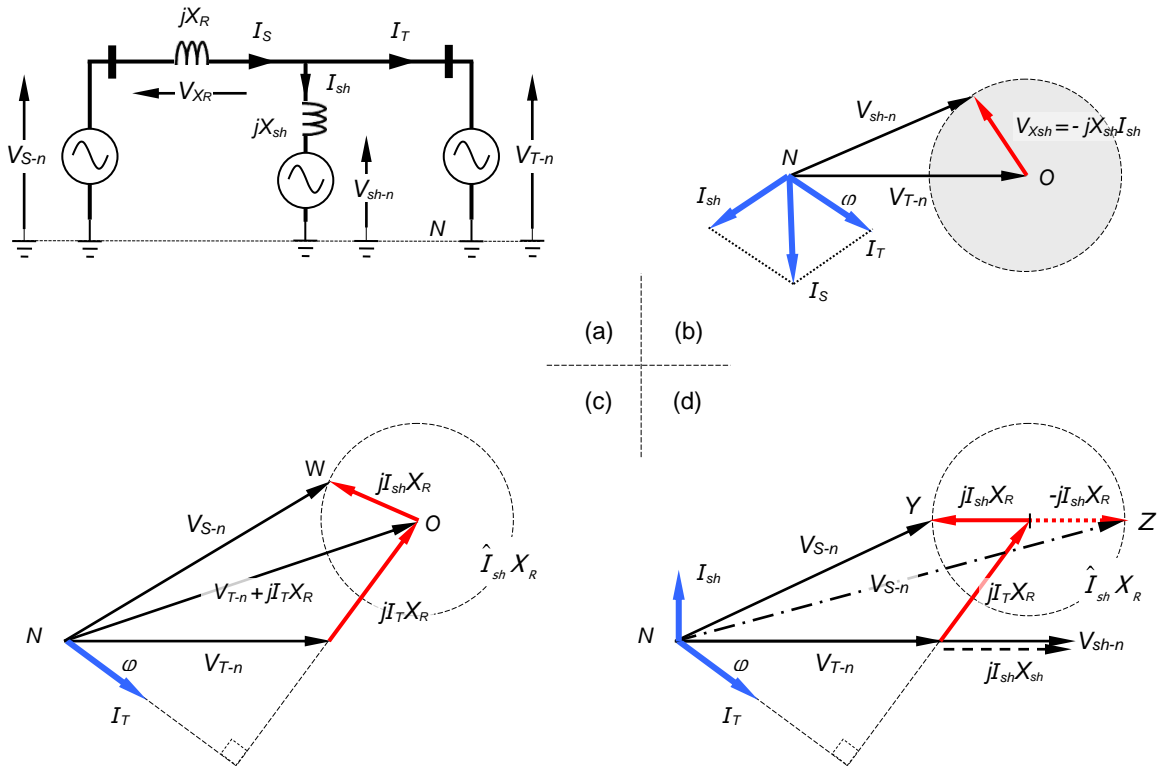

Figure 25.25. Active shunt compensation: (a) shunt compensated network; (b) general shunt voltage compensation phasor diagram; (c) shunt voltage compensation; and (d) quadrature reactive-power shunt current compensation.

Figure 25.25d shows the loci for the case when no real power is transferred by the shunt compensator, since the compensator current I_{sh} is at quadrature to the shunt voltage V_{sh-n} , which is in phase with the load network V_T . The allowable range of variation on the source voltage V_{S-n} is a minimum for phasor N-Y (voltage-swell) and a maximum for phasor N-Z (voltage-sag), as shown in figure 25.25d. This range of possible voltage compensation is determined by the line reactance X_R , which specifies the inverter current rating I_{sh} needed to produce the necessary compensation range, namely the diameter of the circle in figure 25.25c. That is, the lower the line reactance X_R the higher the necessary compensating inverter current rating for a given voltage compensation range.

The shunt compensator operates in a type of current push-pull or sourcing-sinking mode.

- When the source voltage V_s is too high, voltage swell, the shunt draws or sinks current additional to the load current in order to increase the voltage across the line reactance X_R , thereby tending to decrease the load voltage V_T .
- When the source voltage V_s sags, the shunt compensator sources current to the load network V_T , thereby reducing the source current which decreases the voltage across the line reactance X_R , making a higher component of the source voltage available across the load network V_T .

During each mode of operation, the phasor angular relationships must be observed within this simplistic explanation.

The basic shunt converter arrangement can also be used for line current distortion compensation.

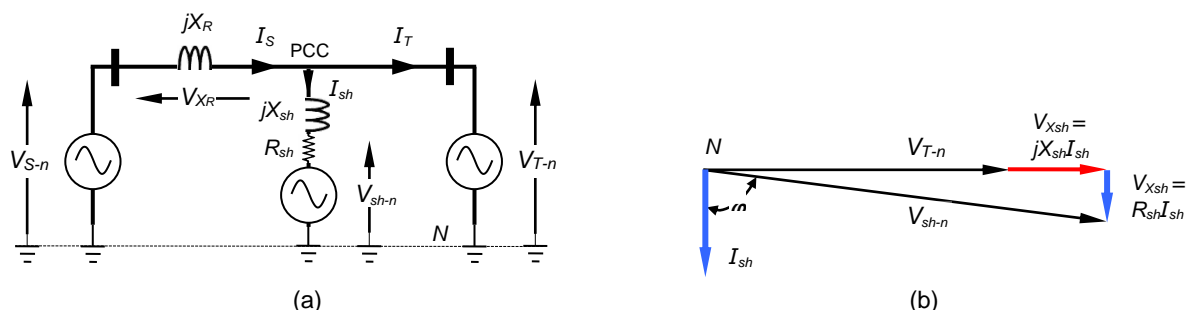

Figure 25.26. Active shunt compensator used for power factor correction: (a) shunt compensated network and (b) phasor diagram.

Power factor correction

The shunt compensator can be used for power factor correction at the PCC. The compensator current I_{sh} is set to be 90° behind the PCC voltage V_{T-n} , with the magnitude of the current I_{sh} determining the magnitude of the compensation. This is achieved by ensuring that the load voltage and shunt regulator voltage are in phase, but the relative magnitudes are varied ($V_{sh-n} > V_{T-n}$). Since only VAR are involved from the shunt regulator, no shunt regulator dc voltage supply source is needed to maintain the dc-link capacitor, except inverter losses must be accounted for. By ensuring the shunt voltage V_{sh-n} slightly lags the line voltage V_{T-n} , the necessary inverter losses can be provided from the grid. If the inverter losses are incorporated, as represented by the resistor in figure 25.26a, then the resultant phasor diagram in figure 25.26b complies with the following output loop voltage equation.

$$V_{sh-n} = I_{sh} R_{sh} + jX_{sh} I_{sh} + V_{T-n} \quad (25.77)$$

The reactive power provided to the ac system from the shunt power factor controller is $Q = I_{sh} V_{T-n}$, while $P = V_{sh-n} I_{sh} \cos\phi$ real power is drawn from the line to cater for the inverter power losses. Since no separated dc-link voltage source is required, the shunt regulator is acting as a STATCOM, as considered previously.

Harmonic current compensation

Figure 25.27 shows a system with a shunt active filter for harmonic current compensation of a non-linear, diode rectifier, where the active filter circuit consists of a three-phase voltage-fed PWM inverter and a dc-link capacitor, C_{dc} . The active filter is controlled to draw the compensating current, i_{AF} , from the utility that cancels the harmonic current flowing on the ac side of the diode rectifier with an inductive dc load.

Consider the ac network per phase configuration of a parallel active filter compensating the current harmonic load shown in figure 25.27a. The non-linear parallel load equivalent current source is I_{T-n} and Z_{L-n} is the non-linear load impedance. G is the transfer function, which has no fundamental component, of the control reference for the active shunt filter to compensate for the load current harmonics seen by the source.

The shunt compensating current is

$$I_{sh} = G I_T$$

Also

$$I_S = \frac{Z_{L-n}}{Z_R + \frac{Z_{L-n}}{1-G}} I_T + \frac{V_{s-n}}{Z_R + \frac{Z_{L-n}}{1-G}}$$

and

$$I_T = \frac{\frac{Z_{L-n}}{1-G}}{Z_R + \frac{Z_{L-n}}{1-G}} I_{L-n} + \frac{1}{1-G} \frac{V_{s-n}}{Z_R + \frac{Z_{L-n}}{1-G}}$$

In satisfying the harmonic requirements

$$\left| \frac{Z_{L-n}}{1-G} \right|_{harm} \gg |Z_R|_{harm} \quad (25.78)$$

Then the three current equations at the PCC become

$$\begin{aligned} I_{sh} &= I_{T-harm} \\ I_{S-harm} &\approx (1-G) I_{T-n-harm} + (1-G) \frac{V_{S-n-harm}}{Z_{L-n-harm}} \approx 0 \\ I_{T-harm} &= I_{T-n-harm} + \frac{V_{S-n-harm}}{Z_{L-n-harm}} \end{aligned}$$

If equation (25.78) is satisfied and $|1-G|_{harm} = 0$, then the source current I_S will be sinusoidal, that is, $I_{S-harm} = 0$ provided $Z_{L-n} \gg Z_{XR}$, as is the usual case.

Equation (25.21) represents the α -phase and β -phase compensating currents:

$$\begin{bmatrix} i_{AF\alpha} \\ i_{AF\beta} \end{bmatrix} = \begin{bmatrix} e_\alpha & e_\beta \\ -e_\beta & e_\alpha \end{bmatrix}^{-1} \begin{bmatrix} p_{AF} \\ q_{AF} \end{bmatrix} \quad (25.79)$$

The powers p_{AF} and q_{AF} are the three-phase instantaneous real and imaginary powers on the ac-side of the active filter, and can be extracted from p_L and q_L , which are the three-phase instantaneous real and imaginary powers on the ac-side of a harmonic-producing (non-linear) load. When the active filter compensates for the harmonic current produced by the non-linear load:

$$p_{AF} = -\tilde{p}_L \quad q_{AF} = -\tilde{q}_L \quad (25.80)$$

where, \tilde{p}_L and \tilde{q}_L are the ac components of p_L and q_L , respectively. The dc components of p_L and q_L correspond to the fundamental current in i_L and the ac components correspond to the harmonic current. Two high-pass filters can be used in the control circuit to extract \tilde{p}_L from p_L and \tilde{q}_L from q_L .

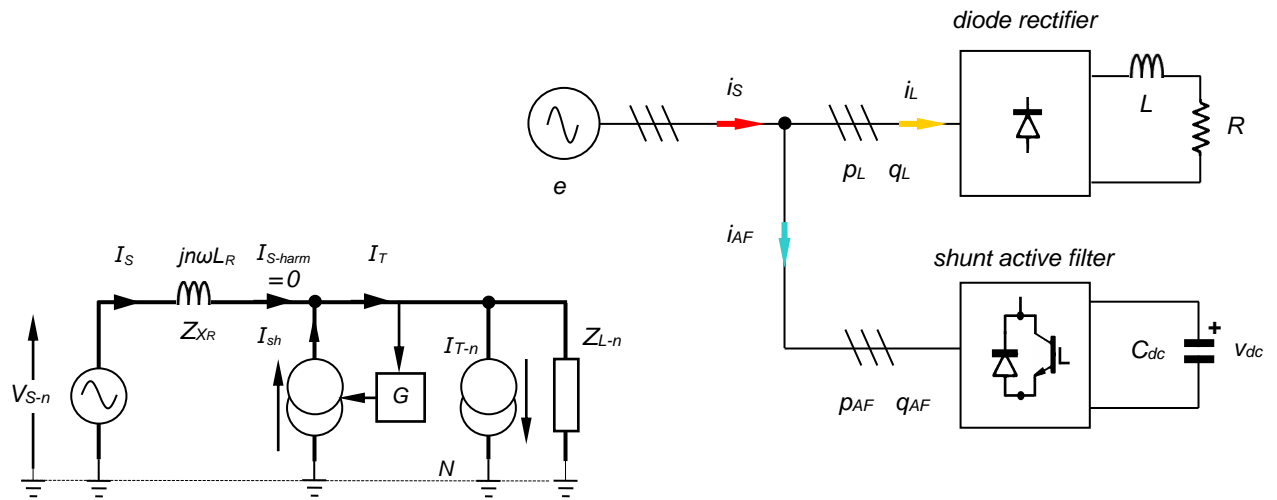

Figure 25.27. Active shunt filter used for ac current distortion compensation.

The active filter draws and releases p_{AF} from the utility, and delivers it to the dc capacitor, assuming no loss dissipation in the active filter. Thus p_{AF} produces a voltage fluctuation on the dc capacitor. The amplitude of p_{AF} is assumed constant, then the lower the frequency of the ac component, the larger the voltage fluctuation. The dc capacitor has to absorb or release electric energy given by the integration of p_{AF} with respect to time. Thus, the relationship between the instantaneous voltage across the dc capacitor, v_{dc} and p_{AF} is:

$$\frac{1}{2} C_{dc} v_{dc}^2(t) = \frac{1}{2} C_{dc} v_{dc}^2(0) + \int_0^t p_{AF} dt \quad (25.81)$$

This implies that the active filter needs large dc capacitance to suppress the voltage fluctuation in order to harmonic compensate p_L . The main purpose of the voltage-fed PWM inverter is to perform an interface conversion between the utility and the dc capacitor.

The active filter draws q_{AF} from the utility, as shown in figure 25.27. However, q_{AF} makes no net contribution to energy transfer in the three-phase circuit. No energy source is required on the dc side of the active filter, independent of q_{AF} , whenever $p_{AF} = 0$.

Voltage distortion compensation

The shunt regulator can be used to cancel line harmonic voltages. If harmonics of the fundamental supply frequency ω are cancelled, the load voltage and current at that frequency are zero as shown in figure 25.28a. Then, from figure 25.28a, where $I_{S-harm} = I_{sh-harm}$

$$V_{S-n-harm} - jI_{S-harm} n\omega L_R = V_{sh-n-harm} + jI_{sh-harm} n\omega L_{sh} \quad (25.82)$$

That is

$$V_{sh-n-harm} = -\frac{L_{sh}}{L_R} \times V_{S-n-harm} \quad (25.83)$$

The necessary cancelling voltage magnitude from the shunt regulator is dependant on the relative magnitudes of the two line reactance's, independent of harmonic frequency. If $L_{sh} > L_R$ the shunt compensator must produce an anti-phase voltage greater in magnitude than the harmonic line voltage. Series compensation techniques are more effective for line voltage distortion compensation, while shunt compensation methods are more effective for line current harmonic compensation.

Consider the ac network per phase configuration of a parallel active filter compensating the voltage harmonic load shown in figure 25.28b. The non-linear load equivalent voltage source is $V_{T-n-harm}$ and $Z_{L-n-harm}$ is the non-linear load impedance.

The shunt compensating current is

$$I_{sh} = G I_T$$

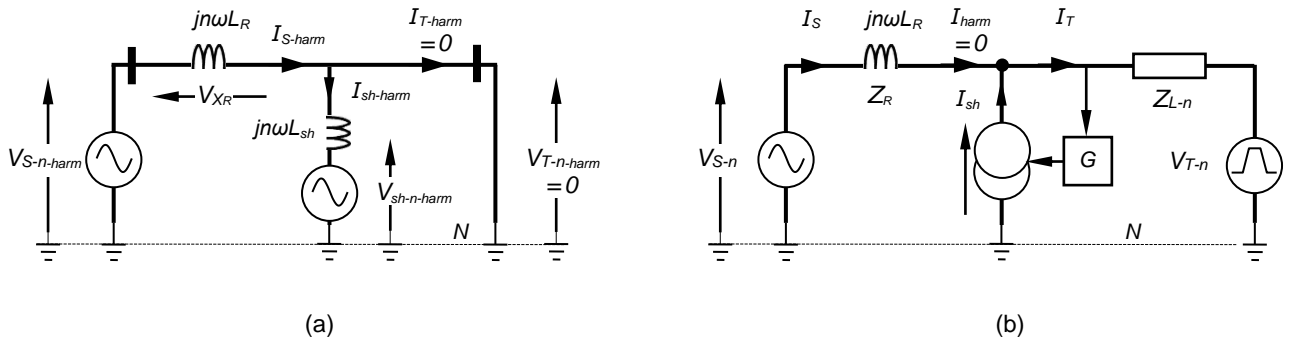

Figure 25.28. Active shunt compensator used for voltage distortion compensation.

Also

$$I_S = \frac{V_{s-n} - V_{T-n}}{Z_R + \frac{Z_{L-n}}{1-G}}$$

and

$$I_T = \frac{1}{1-G} \frac{V_{s-n} - V_{T-n}}{Z_R + \frac{Z_{L-n}}{1-G}} = \frac{V_{s-n} - V_{T-n}}{(1-G)Z_R + Z_{L-n}}$$

In satisfying harmonic requirements

$$\left| Z_R + \frac{Z_{L-n}}{1-G} \right|_{harm} \gg 1$$

Then the three current equations at the PCC become

$$I_{sh} = I_{T-harm} \text{ and } I_{S-harm} \approx 0 \text{ and } I_{T-harm} = \frac{V_{s-n-harm} - V_{T-n-harm}}{Z_L}$$

Since the load impedance Z_L is low, $Z_{L-harm} \rightarrow 0$, then the shunt current flows through the non-linear load voltage not affecting the non-linear load voltage (which is a short circuit ac wise). The source impedance continues to experience the difference between the sinusoidal source and the non-linear load voltage, hence nonlinear source current flow continues unabated.

The four-quadrant P - Q and boundary phasor diagrams for the shunt regulator are shown in figure 25.29.

Table 25.1: Comparison of STATCOM and SVC

property	STATCOM	SVC
I - V characteristic	Current source Good under-voltage performance	Impedance source Good overvoltage performance
Control range	Symmetrical Otherwise hybrid solution	Adjustable with cascaded TCR/TSC
Modularity	Redundancy Compensated ageing degradation Common inverter to other applications	Redundancy Ageing degradation TCR/TSC branches common additions to SVC
Response time	1 to 2 cycles No natural commutation delays	2 to 3 cycles Limited by supply frequency
Transient behaviour	Self protecting on critical system faults	Active before, during and after transient conditions
Volume requirements	40% to 50% of SVC	100%
On-line availability	96% to 98% of time	> 99% of the time
Capital costs	120% to 150% that of SVC	100%

The series and shunt converters are operated to give point of connection voltages

$$\begin{aligned} V_{se} &= |V_{se}|(\cos \theta_{se} + j \sin \theta_{se}) & 0 \leq \theta_{se} \leq 2\pi \\ V_{sh} &= |V_{sh}|(\cos \theta_{sh} + j \sin \theta_{sh}) & 0 \leq \theta_{sh} \leq 2\pi \end{aligned} \tag{25.84}$$

The magnitudes of converter voltages V_{sh} and V_{se} are controlled by the turns ratio of the matching transformers, the PWM modulation depth, and are restricted by the operational voltage limits (both upper and lower voltage limits) imposed by the inverter technology.

$$\begin{aligned} V_{SH} &= m_{SH} \frac{V_{dc}}{2\sqrt{2} n_{SH} V_B} \\ V_{SE} &= m_{SE} \frac{V_{dc}}{2\sqrt{2} n_{SE} V_B} \end{aligned} \tag{25.85}$$

where m is the inverter modulation index, n is the coupling transformer turns ratio, V_B is the transmission side base voltage, and V_{dc} is the back to back inverter dc link voltage.

The effective sending end voltage $V_{S\text{eff}}$, hence power, is controlled by adjusting the series voltage V_{se} , that is

$$V_{S\text{eff}} = V_S + V_{se} \tag{25.86}$$

The active power drawn by the series converter should equal the active power generated by the shunt converter (minus inverter and transformer losses) and vice versa, that is

$$\Re\{-V_{sh} I_{sh}^* + V_{se} I_L^*\} = 0 \tag{25.87}$$

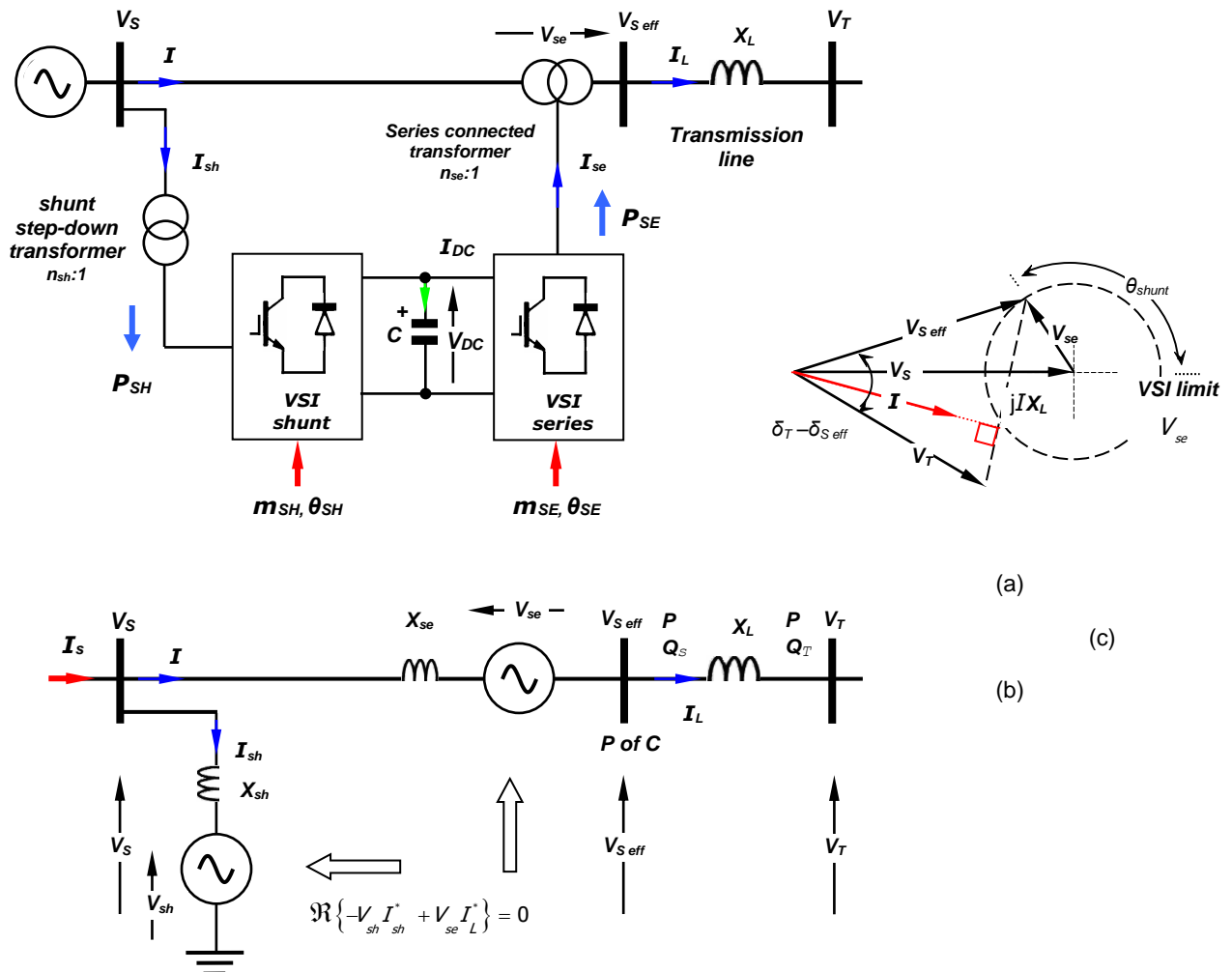

Figure 25.30. Unified power flow controller - UPFC: (a) single line diagram of the UPFC showing decoupled back to back connected inverters and matching transformers; (b) UPFC equivalent circuit; and (c) phasor diagram for system voltages and line current, I_L .

Because line energy can be transferred readily between both converters in compensating for converter and transformer losses, the dc-link capacitor can be small, yet be maintained at the necessary rated link voltage. A consequence of the back-to-back connection is that the dc-link capacitor decouples the two converters and the shunt and series converter reactive powers can be controlled independently. Both converters can provide reactive power, and power for the series converter can be provided via the shunt

converter. Because the series converter can now provide (and absorb) real power, the injected shunt voltage magnitude and relative phase are unrestricted, within the lesser I - V limits of the two inverters. This is shown by the circle in the phasor diagram in figure 25.30c, where unlike for the DVR, as shown in the phasor diagram in figure 25.21c, the line current I_L and the series compensation voltage V_{SE} are not restricted to be at quadrature (that is, real power transfer can be involved with UPFC operation).

The series converter can be operated in any of four modes:

- Voltage regulation - figure 25.31a. The magnitude of the sending bus voltage V_S is regulated (increased or decreased) by injecting a voltage V_{SE} of maximum magnitude V_{SEmax} , in phase (or out of phase) with V_S , thus avoiding the need for a transformer tap changer.
- Line compensation - figure 25.31b. Series reactive compensation is obtained by series injecting a voltage V_{SE} of maximum magnitude V_{SEmax} , orthogonal to the line current I_L . The effective voltage across the line impedance X_L is decreased (or increased) if the voltage V_{SE} lags the current by 90° (or leads the current I_L by 90°).
- Phase angle regulation - figure 25.31c. The required phase shift is realized by injecting a voltage V_{SE} of maximum magnitude V_{SEmax} , that shifts the phase angle of V_S by $\pm\theta$ while keeping the magnitude of V_S constant.
- Power flow control - figure 25.31d. Unified simultaneous control of terminal voltage (figure 25.31a), line impedance (figure 25.31b), and phase angle (figure 25.31c) means the UPFC is able to perform multifunctional power flow control. The magnitude and the phase angle of the series injected voltage V_{SE} is selected so as to produce a line current that results in the desired real and reactive power flow on the transmission line.

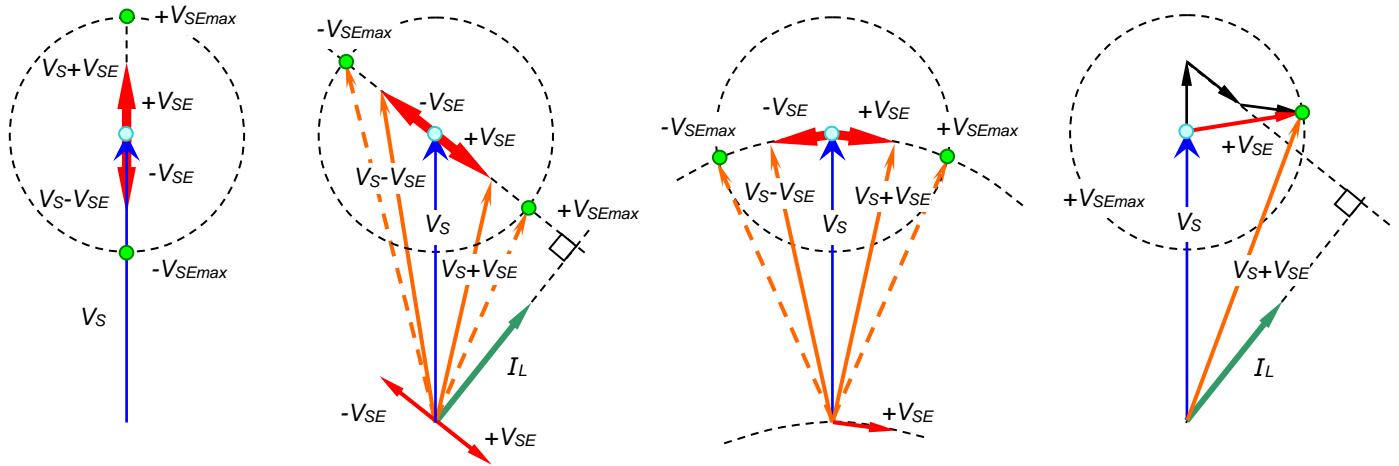

Figure 25.31. Phasor diagrams for the UPFC series operating modes.

The complex conjugate of the complex power at the receiving end of the line is given by

$$S^* = P - jQ = \mathbf{V}_R^* \left(\frac{\mathbf{V}_S + \mathbf{V}_{SE} - \mathbf{V}_T}{jX} \right) \quad (25.88)$$

After compensation, the real and reactive power flows between $V_{S\text{eff}}$ and V_T are given by

$$P = \frac{V_S V_T}{X_L} \sin \delta_T + \frac{V_{S\text{eff}} V_T}{X_L} \sin(\delta_T - \delta_{S\text{eff}}) = P_o(\delta) + P_{SE}(\delta, \delta_{S\text{eff}})$$

$$Q_T = V_T \times \frac{V_{S\text{eff}} \cos(\delta_T - \delta_{S\text{eff}}) - V_T}{X_L} + \frac{V_{S\text{eff}} V_T}{X_L} \cos(\delta_T - \delta_{S\text{eff}}) = Q_o(\delta) + Q_{SE}(\delta, \delta_{S\text{eff}}) \quad (25.89)$$

$$Q_{S\text{eff}} = V_{S\text{eff}} \times \frac{V_{S\text{eff}} - V_T \cos(\delta_T - \delta_{S\text{eff}})}{X_L}$$

If $V_{S\text{eff}} = 0$ the real and reactive power of the uncompensated system result, as given by equations (25.6) and (25.8). The maximum P - Q compensation components, $V_T V_{SE\text{max}}/X_L$, occur when $\delta_T - \delta_{S\text{eff}} = \frac{1}{2}\pi$. The series DVR compensator can give a voltage between 0 and $V_{SE\text{max}}$ with a rotational angle between 0 and 360° . This circle, with centre P_o , Q_o , and radius $V_T V_{SE\text{max}}/X_L$, can be defined by

$$\left(P(\delta, \delta_{SE}) - P_o(\delta) \right)^2 + \left(Q(\delta, \delta_{SE}) - Q_o(\delta) \right)^2 = \left(\frac{V_T V_{SE\text{max}}}{X_L} \right)^2 \quad (25.90)$$

Figure 25.32 shows a series of loci of the reactive power Q demanded at the receiving bus versus the transmitted real power P as a function of the series voltage magnitude V_{SE} and phase angle δ_{SE} at three different power angles δ , namely, $\delta = 0^\circ$, 45° , and 90° , with $V_S = V_T = V$, $V^2/X_L = 1$, and $V_T V_{SE\ max}/X_L = 1/2$. Figure 25.32 shows that the UPFC can independently control real and reactive power flow at any transmission angle.

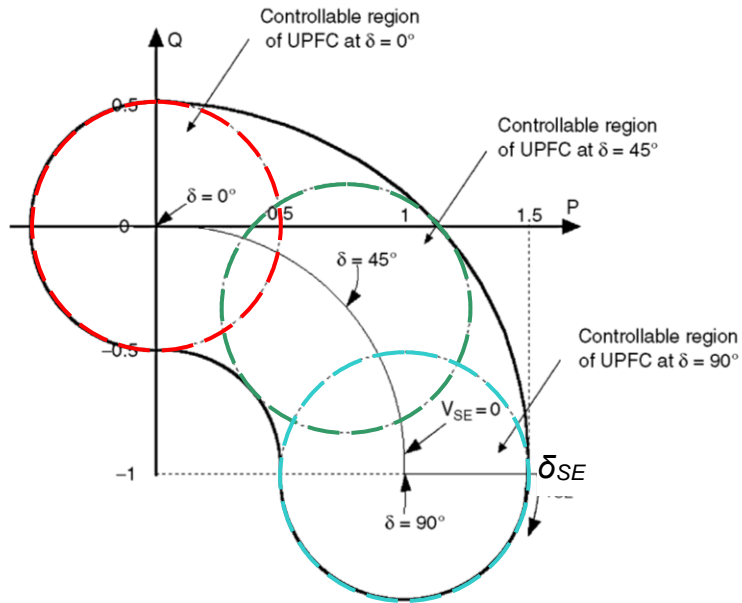

Figure 25.32. Unified power flow controller – UPFC, P - Q relationship for a two-bus system for three power angles, $\delta = 0^\circ$, 45° , and 90° , with $V_S = V_T = V$, $V^2/X_L = 1$, and $V_T V_{SE\ max}/X_L = 1/2$.

If bidirectional transmission line power flow control is required, a shunt compensator is needed at the opposite line end to the UPFC. Therein lies the overlooked fundamental conceptual limitation of the UPFC. Ideally, shunt compensation is most effective at the line reactance midpoint, while series compensation is most effective at a transmission line end. With the UPFC, both forms of compensation, shunt STATCOM and series DVR, occur at the same single point of connection.

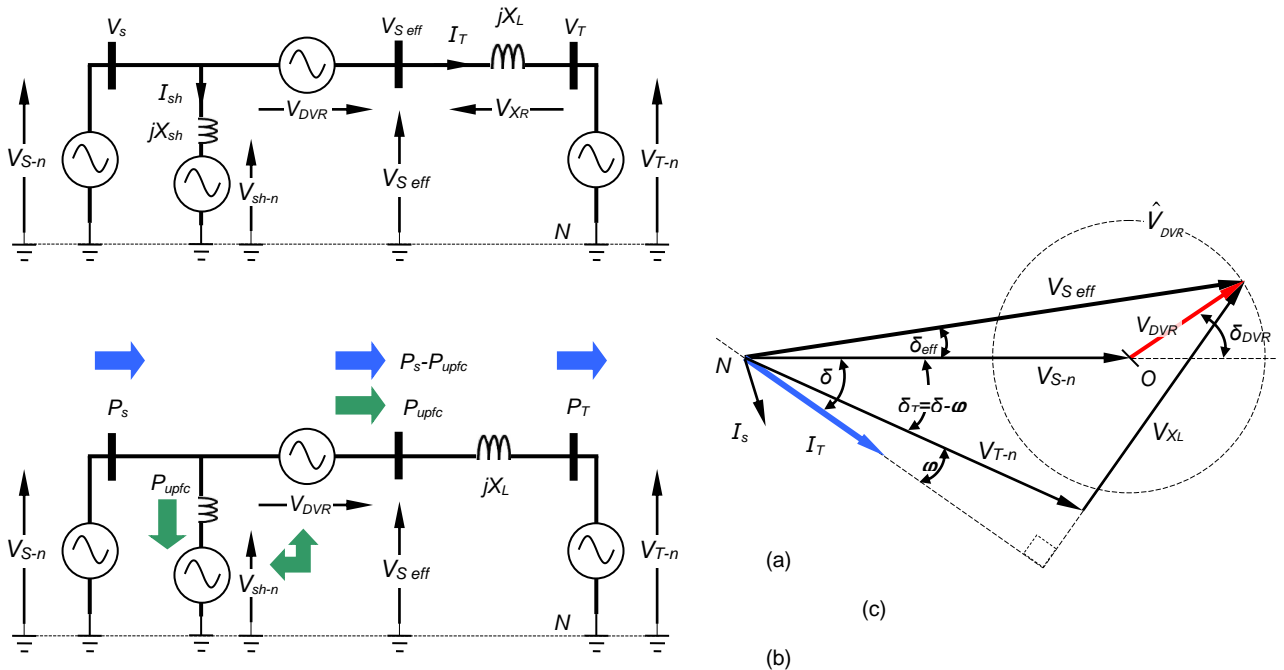

Figure 25.33. Unified power flow controller - UPFC: (a) single line diagram of the UPFC; (b) UPFC power flow diagram; and (c) phasor diagram for system voltages and line current, I_T .

With the aid of the phasor diagram in figure 25.33c, the following power equations can be derived. The source grid V_S delivered powers are

$$\begin{aligned} P_S &= V_{S-n} I_T \cos \delta \\ Q_S &= V_{S-n} I_T \sin \delta \end{aligned} \quad (25.91)$$

The UPFC powers, from the phasor diagram in figure 25.33c are

$$\begin{aligned} P_{UPFC} &= V_{DVR} I_T \cos(\delta_{DVR} - \delta) \\ Q_{UPFC} &= V_{DVR} I_T \sin(\delta_{DVR} - \delta) \end{aligned} \quad (25.92)$$

The line inductance VAR is

$$Q_{XR} = Q_{S\text{eff}} - Q_T = \frac{V_L^2}{X_L} = I_T^2 X_L \quad (25.93)$$

Alternatively, using the phasor diagram in figure 25.33c, the terminal grid V_T received powers are

$$\begin{aligned} P_T &= V_{T-n} I_T \cos(\phi - \delta) \\ Q_T &= V_{T-n} I_T \sin(\phi - \delta) \end{aligned} \quad (25.94)$$

From equation (25.92) four modes of UPFC control can be deduced:

- If $\delta_{DVR} = \delta$, no reactive power flow is contributed from or controlled by the series DVR, while maximum active power is contributed.
- If δ_{DVR} is at quadrature to δ , the DVR acts as a phase shifter and controls the active power but the reactive power is at a maximum.
- If δ_{DVR} is at quadrature to the line current I_T , the active power flow is controlled with the DVR acting as a controllable series reactive element.
- For other δ_{DVR} the UPFC becomes a combined phase shifter and variable series reactive compensator.

An important feature of the UPFC is that any energy for compensation at 50/60Hz and/or for harmonic compensation, is drawn from the network as sinusoidal current. This is unlike when the energy for the dc-link capacitor is provided via a rectifier fed from the ac network, where the rectification process itself can produce substantial harmonic currents in the network.

25.10 Combined active and passive filters

The basic static synchronous compensators (shunt - STATCOM and series - DVR) can be used simultaneously for both 50/60Hz fundamental power quality improvement and control as well as for line harmonic filtering, by injecting current or voltage, as appropriate, at the PCC. In the harmonic filtering mode, the compensators basically inject anti-phase current and voltage harmonics. In order to do so, the PWM frequency of the compensator inverter must be at least twice that of the highest frequency harmonic to be cancelled.

25.10.1 - Current compensation – shunt filtering

As shown in figure 25.34a, the static synchronous shunt compensator can be used to shunt inject equal but opposite magnitude harmonic compensating currents such that

$$I_S = I_{shunt} + I_L \quad (25.95)$$

The load current I_L is non-linear, as with rectification for highly inductive loads. The compensator shunt injects a current I_{shunt} such that the supply current I_S is a pure sinusoid at the fundamental frequency. The sending voltage source V_L sees the transmission system as a purely resistive load, if STATCOM normal VAR compensation is also operational.

The STATCOM output is second order L - C low pass filtered to prevent PWM carrier components from being injected into the ac system. A second order L - C high-pass shunt line filter is normally incorporate to cater for current frequency components at the modulation frequency and beyond the shunt compensator's bandwidth. The high cut-off frequency, well beyond the power frequency, results in reduced size, as well as reduced possibility of resonant effects.

25.10.2 - Voltage compensation – series filtering

As shown in figure 25.34b, the static synchronous series compensator can be used to series inject equal but opposite magnitude harmonic compensating voltages into the line such that

$$V_S = V_{series} + V_L \quad (25.96)$$

The load current I_L and voltage V_L are both non-linear, since the non-linear current associated with the rectification of highly inductive loads produces non-sinusoidal voltages across the series line inductance,

normally around the peaks and troughs of the three-phase sine-waves. The compensator series injects a voltage V_{series} such that the sinusoidal supply voltage V_s delivers a more sinusoidal current into the transmission line. Since the load still draws a non-linear current, passive notch-shunt and high-pass shunt second order $L-C$ filtering are needed to provide a bypass path for the current harmonics. The series compensator output is second order $L-C$ low pass filtered to prevent PWM carrier components from being injected into the ac system.

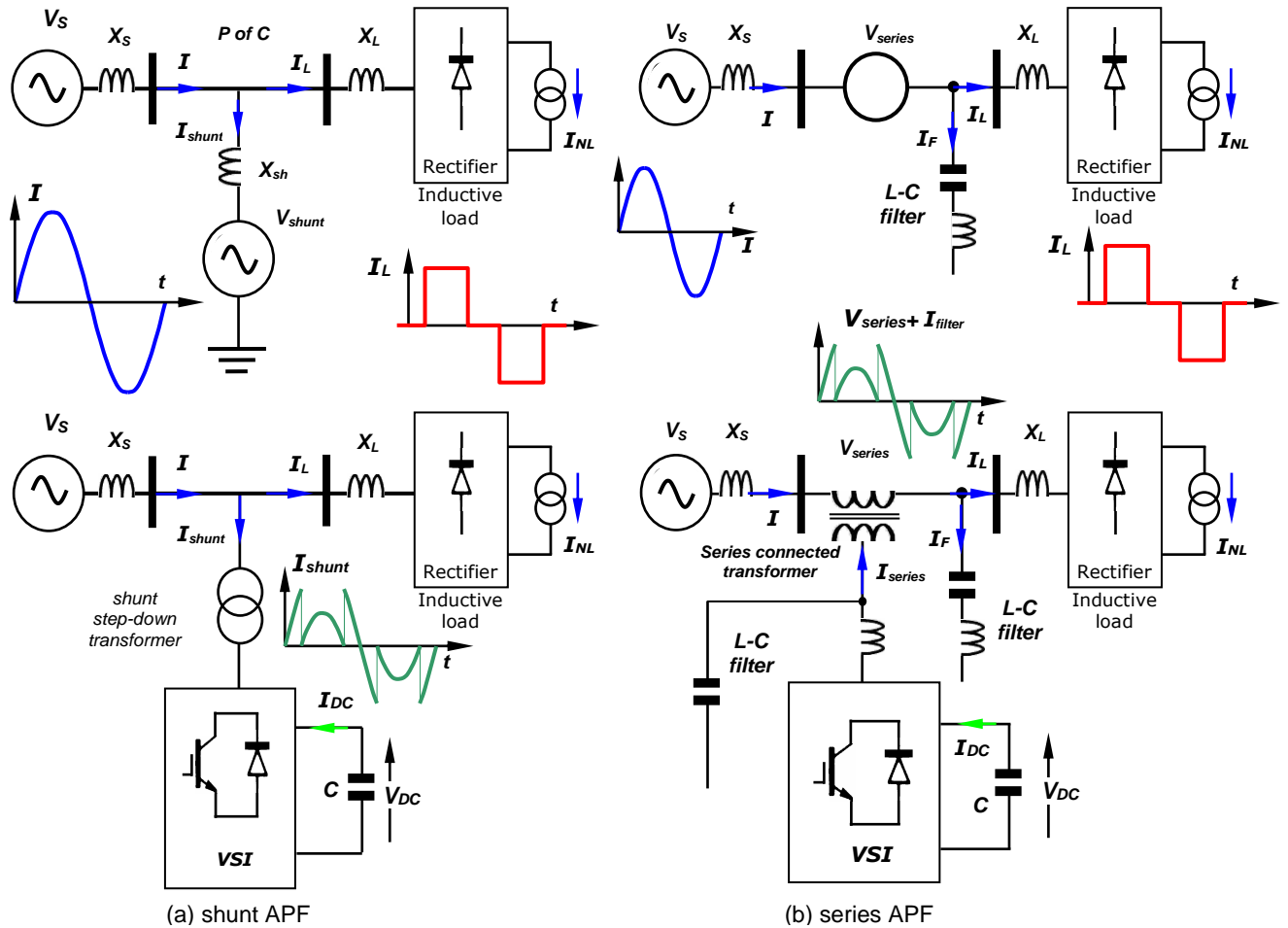

Figure 25.34. Combined active and passive filters: (a) transformer voltage matched shunt APF and (b) transformer voltage matched series APF.

25.10.3 - Hybrid arrangements

STATCOM-based hybrid arrangements can be used for both voltage regulation and load-compensation. STATCOMs are usually combined with SVCs or passive harmonics filters. While both provide improvement to compensation capabilities, the former are often used for voltage regulation, while the latter are utilised for load compensation. Additionally, in hybrid topologies, the rated power of STATCOM constitutes a part of a hybrid controller’s rated power thus they allow the installation costs to be reduced. Shown in the parts of figure 25.35 are general topologies and $I-V$ characteristics of STATCOM SVC hybrid arrangements. The parallel connected SVC part extends the current operating region of the STATCOM. The combination of the STATCOM and TSC (Figure 25.35a) extends the operating region towards the generation of reactive power (capacitive region). This property is important in practice, because it is often necessary in distribution systems to compensate inductive-type loads to provide terminal-voltage regulation. Extension of the $I-V$ characteristics of the STATCOM towards absorption of reactive power (inductive region) is possible by paralleling it with the TSR (figure 25.35b). The symmetrical extension of the $I-V$ characteristics is provided by the hybrid arrangement shown in Figure 25.35c. In addition to improving $I-V$ characteristics, a hybrid arrangement can be used to optimize losses, cost, and performance for a particular application.

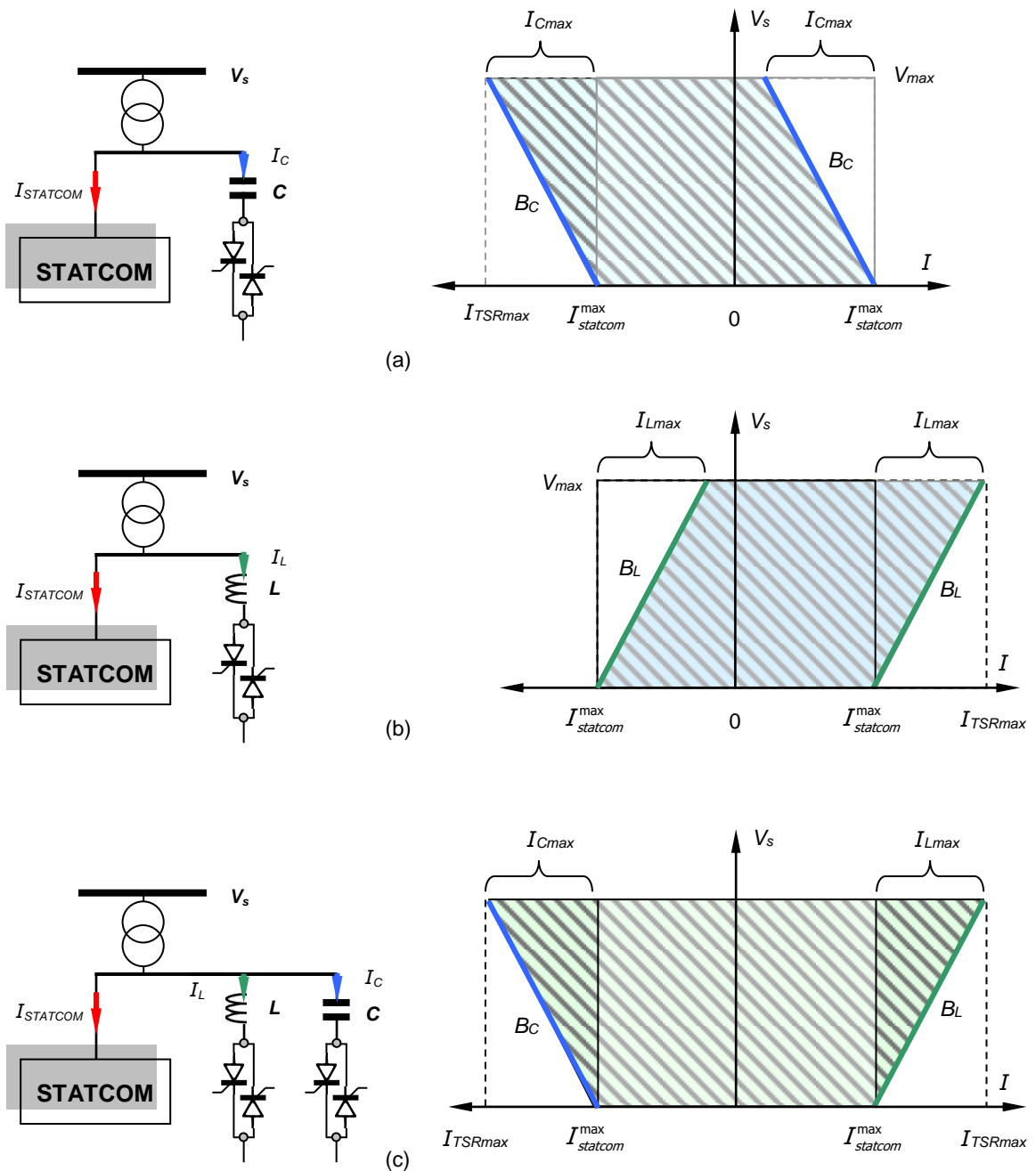

Figure 25.35. Combined STATCOM and thyristor static controller and hybrid I-V characteristics: (a) STATCOM and TSC; (b) STATCOM and TSR; and (c) STATCOM plus TSR and TSC.

25.10.4 - Active and passive combination filtering

All effective active filtering relies on the addition of passive filtering, even if only to filter compensator inverter pwm outputs.

Semiconductor voltage ratings usually prevent the direct coupling of the compensator inverter to the ac grid. At 50/60Hz, transformer coupling provides a simple and efficient interface method. But for active filtering application, the coupling transformer must have sufficient bandwidth to transmit the necessary compensating harmonic components. Normal 0.3mm silicon steel laminated transformer cores produce transformers suitable for compensation of the 5th and 7th harmonics, but attenuation at the 12th and 13th harmonics results in the inverter dc-link voltage being ineffectively utilised. Special steels (higher silicon) and thinner laminations (0.1mm and 0.05mm) cater for higher frequency operation but as well as being more costly, maximum flux density levels are decreased and core losses are increased. High permeability, amorphous metal-based soft magnetic materials offer modest high frequency losses with high flux densities properties, but are expensive. Indirect filtering methods involving the normal 0.3mm 50/60Hz steels may therefore be preferred.

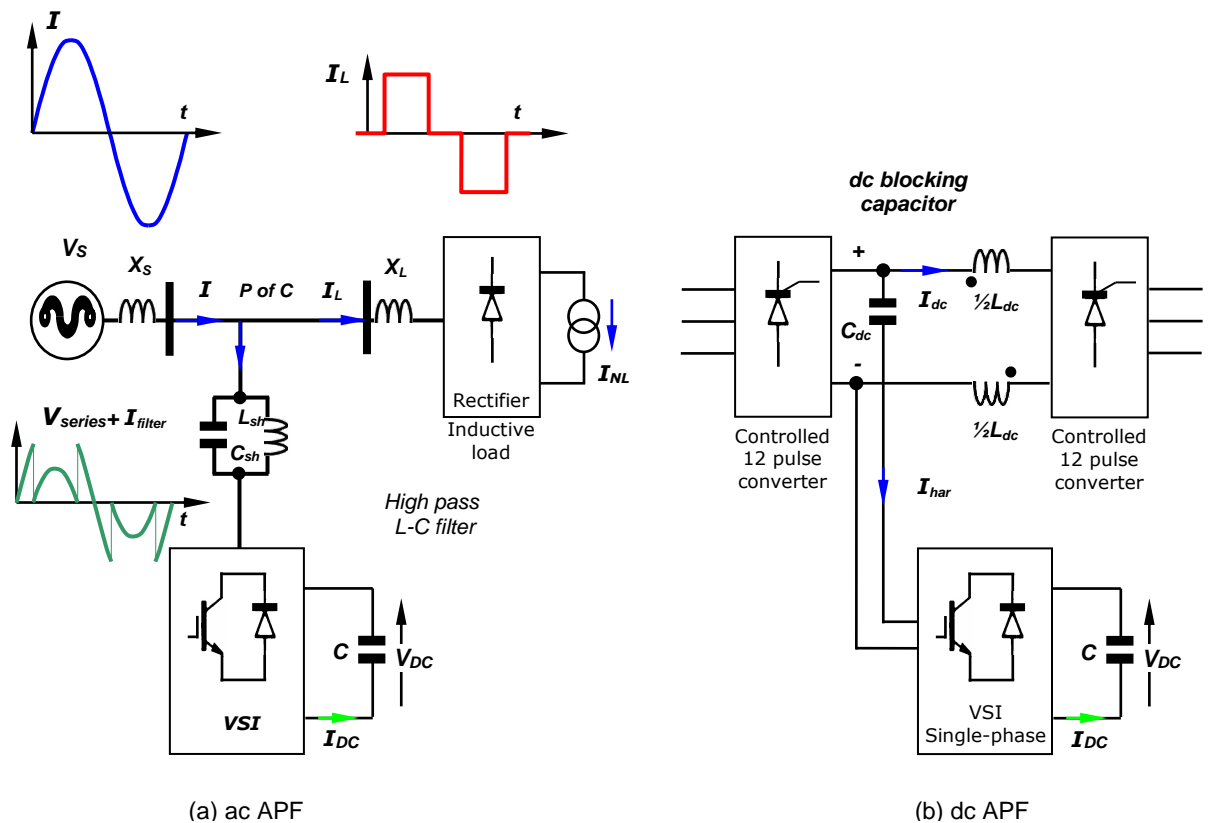

Figure 25.36. Combined transformerless active and passive power filters: (a) 50/60Hz ac decoupled shunt APF method and (b) dc decoupled shunt APF approach.

Figure 25.36 shows indirect filter coupling methods suitable for dc and ac lines where the active filter is dc or 50/60Hz decoupled to the transmission system. The series filter (L_{sh}/C_{sh} and C_{dc}) supports the system voltage while the inverter experiences only its own low dc-link voltage. The method is effective for ac but has limitations:

- the passive decoupling filter characteristics drift in time, namely the notch frequency and Q ;
- the large size and weight of the filter inductor, being based on 50/60Hz design concepts;
- the inverter is only capable of harmonic compensation without VAR compensation since the 50/60Hz decoupling filter blocks any transfer at the 50/60Hz line transmission frequency. For VAR compensation, the inverter fundamental output voltage must be of a similar magnitude as the line voltage, hence the use of a voltage-matching transformer.

These ac limitations are not relevant to dc-link filtering since dc decoupling capacitor ageing characteristics do not affect the block frequency, being dc (VAR compensation is not relevant to dc systems). A single-phase inverter bridge is used for dc-link harmonic compensation. Although the dc-link current harmonics at $12n$ can be cancelled (in a symmetrically triggered 12-pulse system), cancellation of the 11^{th} and 13^{th} order ($12n \pm 1$) ac side current harmonics is more problematic since the rectifying process does not necessarily ensure harmonic current flow in the correct rectifier leg. This is problematic with 12-pulse (and >12) converters.

In the case of ac transmission, transformerless series power filtering is possible since lower voltages are normally involved, but usually a separate isolated single-phase inverter is needed in each phase. The inverter default mode is to operate with all (upper or lower) switches on so that the series compensator is seen as a short circuit.

25.11 Summary of compensator comparison and features

FACTS devices enhance high-voltage ac-grids by:

- increase of power transfer without adding new transmission lines
- transmission cost minimization
- steady-state and dynamic voltage control
- reactive power control of dynamic loads
- active damping of power oscillations

- increase of reliability under system contingencies
- improvement of system stability and voltage regulation and quality - high flexibility for embedding of various energy sources
- load flow control in meshed systems

A shunt compensator acts like a controllable current source and can draw or inject reactive leading or lagging current at the point of connection.

Objectives of dynamic shunt compensation are

- steady state and transient voltage control
- reactive power control of transient loads
- damping of active power oscillations
- increase of system stability

A series compensator is a driving voltage at the line reactance midpoint, hence is more effective than a shunt compensator for controlling current and power flow, and for damping oscillations. It can only supply or absorb reactive power. When used as a phase angle controller, at the sending or receiving ends, a real power source is required.

Table 25.2: Summary of Flexible AC Transmission System (FACTS) Devices

Functionalities	Series devices					Shunt devices	
	TCSC	TSSC	Dynaflow	SSSC	DVR	SVC	STATCOM
Main component	Fixed capacitor plus thyristor	Fixed capacitor, switched capacitor plus thyristor	TSSC combined with phase shift transformer	IGBT based voltage source converter	IGBT based voltage source converter	Thyristor, capacitor and reactor	IGBT based voltage source converter
Reactive power compensation	Yes but discrete	Yes but discrete	Yes but discrete	Yes, continuous	Yes, continuous	Yes but discrete	Yes, continuous
SSR damping	good	good	very good	excellent	possible	limited	limited
Inter-area oscillation damping	very good	very good	very good	very good (effective than PSS)	Is possible if configured	limited	limited
Active power capability	very limited	Small but better than TCSC	Better than TSSC and TCSC	very limited	very limited	no	no
Active power control capability	yes	yes	yes	yes	yes	no	no
Applications	Transmission system for SSR damping, extending steady-state stability limits and reactive power compensation	Transmission system for SSR damping, extending steady-state stability limits and reactive power compensation	Transmission system for SSR damping, extending steady-state stability limits and reactive power compensation	Transmission system for SSR damping, extending steady-state stability limits and reactive power compensation	Distribution system to reduce effect of imbalance loading	Transmission system for dynamic reactive power compensation, improving the fault ride-through capability of wind farms and flicker mitigation	Transmission system for SSR damping, extending steady-state stability limits, improved power quality and reduce voltage variation
Loss minimization	yes	yes	yes				
Harmonic attenuation	no	no	no	no (only sub-synchronous)	no	Is possible, but in this case it called load balancer	Is possible, but in this case it is called APF
Unbalanced Minimization	no	no	no	no	yes	yes (depends on configuration)	no
Blackout prevention	no	no	no	no	no	no	no
Voltage instability prevention	limited	limited	limited	limited	limited	yes	yes
Voltage quality improvement	limited	limited	limited	limited	limited	yes	yes
Manufacturers	ABB, SIEMENS, GE	ABB, SIEMENS, GE	ABB	ABB	ABB	ABB, SIEMENS, AREVA, American Superconductor	ABB, SIEMENS, AREVA, American Superconductor

TCSC=Thyristor control series capacitor, TSSC=Thyristor-switched series capacitor, SSSC=static synchronous series compensator, DVR=dynamic voltage restorer, SVC=static VAR compensator, STATCOM = static synchronous compensator, APF=active power filter, PSS=power system stabilizer.

Note that SSSC and DVR have the same structure with different control objectives.

Therefore, both control objectives can be combined in one device, the same is also valid for STATCOM and APF

Objectives of dynamic series compensation are

- reduction of load dependent voltage drops
- reduction of system transfer impedance
- reduction of transmission angle
- increase of system stability
- load flow control to specific power branches
- damping of active power oscillations

Two points to bear in mind when transformer coupling compensation FACTS type devices.

- The transformer core must be able to transmit at the highest harmonic frequency.
- Series coupling into a dc link imposes a dc bias current, hence flux in the coupling core.

Table 25.2 provides a comprehensive summary of FACTS devices; including applications, capabilities, and limitations.

25.12 Summary of the advantages of AC transmission over DC transmission

The general advantages of ac transmission, over dc transmission, are

- no costs associated with ac-dc-ac conversion equipment
- transformer (and autotransformer) voltage matching
- reactive power and harmonics readily compensated
- not restricted to only point-to-point connection, as is HVDC (there is one exception)
- established system control methods
- no ac transformer dc voltage stressing due to asymmetrical phase control alignment, and no I^2R and core losses due to high harmonic currents
- ac switch gear and breakers, (and particularly vacuum circuit breakers up to 33kV) are effective - compared with the difficulties in breaking dc current
- lower current harmonics

Reading list

Mohan, N., *Power Electronics*, 3rd Edition,
Wiley International, 2003.

Broad Categories	Specific Categories	Methods of Characterization	Typical Causes
Transients	Impulsive	Peak magnitude, rise time and duration	Lightning strike, transformer energization, capacitor switching
	Oscillatory	Peak magnitude, frequency components	Line or capacitor or load switching.
	Sag	Magnitude, duration	Ferroresonant transformers, single line-to-ground faults
Short duration voltage variation	Swell	Magnitude, duration	Ferroresonant transformers, single line-to-ground faults
	Interruption	Duration	Temporary (self-clearing) faults
Broad Categories	Specific Categories	Methods of Characterization	Typical Causes
Long duration voltage variation	Undervoltage	Magnitude, duration	Switching on loads, capacitor deenergization
	Overvoltage	Magnitude, duration	Switching off loads, capacitor energization
	Sustained interruptions	Duration	Faults
Voltage imbalance		Symmetrical components	Single-phase loads, single-phasing condition
Waveform distortion	Harmonics	THD, Harmonic spectrum	Adjustable speed drives and other nonlinear loads
	Notching	THD, Harmonic spectrum	Power electronic converters
	DC offset	Volts, Amps	Geo-magnetic disturbance, half-wave rectification
Voltage flicker		Frequency of occurrence, modulating frequency	Arc furnace, arc lamps