

# CHAPTER 21

## DC to DC Converters

### - Resonant Mode

DC-dc/ac converters have two shortcomings when their switches operate in a hard switched mode.

- During the turn-on and turn-off transients, the switches experience simultaneous high current and voltage, resulting in high power losses, hence high switch stresses. The power loss increases linearly with the switching frequency. To ensure power conversion efficiency, the switching frequency has to be constrained.
- Electromagnetic interference (EMI) is generated by switch  $dv/dt$  and  $di/dt$ . The drawbacks have been accentuated by the trend to increase switching frequency in order to reduce the converter size and weight.

The resonant converters minimize these two shortcomings. The switches in resonant converters create a square-wave-like voltage or current waveform with or without a DC component. A resonant  $L$ - $C$  circuit is incorporated with a resonant frequency close to the switching frequency, which can be varied around the resonant frequency. When the resonant  $L$ - $C$  circuit frequency is approximately the switching frequency, unwanted harmonics are removed by the circuit. Variation of the switching frequency is a means of controlling the output power and voltage, as is varying the duty cycle.

$L$ - $C$  resonant converter circuits offer:

- sinusoidal-like wave shapes,
- inherent filter action,
- reduced  $dv/dt$ ,  $di/dt$ , and EMI (radiated and conducted switching noise),
- facilitation of the turn-off process by providing zero current crossing for the switches and output power and voltage control by changing the switching frequency, and
- zero current and/or zero voltage across the switches at switching thus substantially reducing switch losses.

Unlike hard switched converters the switches in soft switched converters, quasi-resonant and some resonant converters are subjected to much lower switching stresses. Note that not all resonant converters offer zero current and/or zero voltage switching, that is, reduced switching power losses. These advantageous features are traded for switches that are subjected to higher forward currents and reverse voltages than encounter in a non-resonant configuration of the same power. Variable operating frequency can be a drawback, but varying H-bridge squarewave duty cycle is an alternative.

Two main resonant techniques can be used to achieve near zero switching losses

- a resonant load that provides natural voltage or current zero instances for switching
- a resonant circuit across the switch which feeds energy to the load as well as introducing zero current or voltage instances for switching.

DC to ac resonant converters for induction heating type applications are considered in Chapter 18.3.

#### 21.1 Series-loaded series-resonant dc to dc converters

The basic converter operating concept involves a H-bridge producing an ac square-wave voltage  $V_{H,B}$ . When fed across a series  $L$ - $C$  filter, a near sinusoidal oscillation current results, provided the square-wave fundamental frequency is near the natural resonant frequency of the  $L$ - $C$  filter. Because of  $L$ - $C$  filter action, only fundamental current flows and current harmonics produced by the square-wave voltage are attenuated due to the gain roll-off of the second order  $L$ - $C$  filter. The sinusoidal resonant current is rectified to produce a load dc voltage  $V_{o,p}$ . The output voltage (voltage gain is less than unity) is highly dependant on the frequency relationship between the square-wave drive voltage period and the  $L$ - $C$  filter resonant frequency.

Figure 21.1a shows the circuit diagram of a series resonant converter, which uses an output full-wave rectifier bridge to convert the resonant ac current oscillation into dc. The converter is based on the series converter in figure 18.2b. The rectified ac output charges the dc output capacitor, across which is the dc load,  $R_{load}$ . The non-dc-decoupled resistance, which determines the circuit  $Q$ , is account for by resistor  $R_c$ . The dc capacitor  $C$  capacitance is assumed large enough so that the output voltage  $V_{o,p}$  is maintained constant, without significant ripple voltage. Figures 21.1b and c show how the dc output circuit can be transformed into an ac square-wave in series with the  $L$ - $C$  circuit, and finally this source is transferred to the dc link as a constant dc voltage source  $V_{o,p}$  which opposes the dc supply  $V_s$ . These transformation steps enable the series  $L$ - $C$ - $R$  resonant circuit to be analysed with square-wave inverter excitation, from a dc source  $V_s - V_{o,p}$ . This highlights that the output voltage must be less than the dc supply, that is  $V_s - V_{o,p} \geq 0$ , if current oscillation is to occur. The analysis in chapter 18.3 is valid for this circuit, where  $V_s$  is replaced by  $V_s - V_{o,p}$ . The equations, modified, are repeated here for completeness.

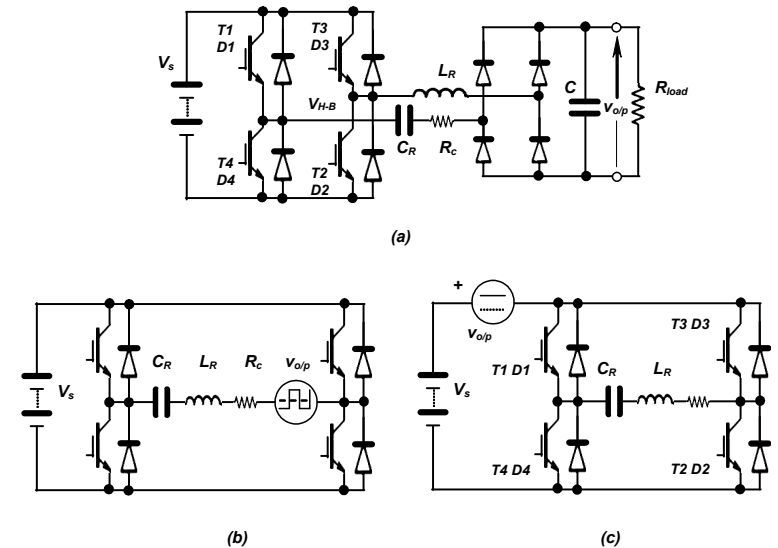

Figure 21.1. Series resonant converter and its equivalent circuit derivation.

The series  $L$ - $C$ - $R$  circuit current for a step input voltage  $V_s - V_{o,p}$ , with initial capacitor voltage  $v_o$ , assuming zero initial inductor current, is given by

$$i(\omega t) = \frac{(V_s - V_{o,p}) - v_o}{\omega L} \times e^{-\alpha t} \times \sin \omega t \quad (21.1)$$

where

$$\omega^2 = \omega_o^2 (1 - \xi^2) \quad \omega_o = \frac{1}{\sqrt{L_r C_r}} \quad \alpha = \frac{R_c}{2L_r} \quad Z_o = \sqrt{\frac{L_r}{C_r}}$$

$\xi$  is the damping factor. The capacitor voltage is important because it specifies the energy retained in the  $L$ - $C$ - $R$  circuit at the end of each half cycle.

$$v_c(\omega t) = (V_s - v_{o/p}) - ((V_s - v_{o/p}) - v_o) \frac{\omega_o}{\omega} e^{-\alpha t} \cos(\omega t - \phi) \quad (21.2)$$

where

$$\tan \phi = \frac{\alpha}{\omega} \quad \text{and} \quad \omega_o^2 = \omega^2 + \alpha^2$$

At the series circuit resonance frequency  $\omega_o$ , the lowest possible circuit impedance results,  $Z = R_c$ . The series circuit quality factor or figure of merit,  $Q_s$  is defined by

$$Q_s = \frac{\omega_o L}{R_c} = \frac{1}{2\xi} = \frac{Z_o}{R_c} \quad (21.3)$$

Operation is characterised by turning on switches T1 and T2 to provide energy from the dc source during one half of the cycle, then having turned T1 and T2 off, T3 and T4 are turned on for the second resonant half cycle. Energy is again drawn from the dc supply, and when the current reaches zero, T3 and T4 are turned off.

Without bridge freewheel diodes, the switches support high reverse bias voltages, but the switches control the start of each oscillation half cycle. With freewheel diodes the oscillations can continue independent of the switch states. The diodes return energy to the supply, hence reducing the net energy transferred to the load. Correct timing of the switches minimises currents in the freewheel diodes, hence minimises the energy needlessly being returned to the supply. Energy to the load is maximised. The switches can be used to control the effective load power factor. By advancing turn-off to occur before the switch current reaches zero, the load can be made to appear inductive, while delaying switch turn-on produces a capacitive load effect.

The series circuit steady-state current at resonance for the H-bridge with a high circuit Q can be approximated by assuming  $\omega_o \approx \omega$ , such that:

$$i(\omega t) = \frac{2}{1 - e^{-\alpha t}} \times \frac{(V_s - v_{o/p})}{\omega L_r} \times e^{-\alpha t} \times \sin \omega t \quad (21.4)$$

which is valid for the  $\pm (V_s - v_{o/p})$  voltage loops of cycle operation at resonance. For a high circuit Q this equation is approximately

$$i(\omega t) \approx \frac{4}{\pi} \times Q \times \frac{(V_s - v_{o/p})}{\omega_o L_r} \times \sin \omega_o t = \frac{4}{\pi} \times \frac{(V_s - v_{o/p})}{R_c} \times \sin \omega_o t \quad (21.5)$$

The maximum current is

$$\hat{I} \approx \frac{4}{\pi} \times \frac{(V_s - v_{o/p})}{R_c} \quad (21.6)$$

while the average current with this peak value must equal the load current, that is

$$\bar{I} = \frac{2}{\pi} \times \hat{I} = \frac{8}{\pi^2} \times \frac{(V_s - v_{o/p})}{R_c} = \frac{v_{o/p}}{R} \quad (21.7)$$

The output voltage is obtained from equation (21.7) by isolating  $v_{o/p}$

$$v_{o/p} = \frac{V_s}{1 + \frac{8}{\pi^2} \times \frac{R_c}{R}} \quad (21.8)$$

In steady-state the capacitor voltage maxima are

$$\begin{aligned} \hat{V}_c &= (V_s - v_{o/p}) \frac{1 + e^{-\alpha t/\omega}}{1 - e^{-\alpha t/\omega}} = (V_s - v_{o/p}) \times \coth(\alpha t / 2\omega) = -\hat{V}_c \\ &\approx (V_s - v_{o/p}) \times 2\omega_o / \alpha \pi = \frac{4}{\pi} \times Q \times (V_s - v_{o/p}) \end{aligned} \quad (21.9)$$

The peak-to-peak capacitor voltage, by symmetry is therefore

$$V_{c,p-p} \approx \frac{8}{\pi} \times Q \times (V_s - v_{o/p}) \quad (21.10)$$

The energy lost in the coil resistance  $R_c$ , per half sine cycle (per current pulse) is

$$\begin{aligned} W &= \int_0^{\pi/\omega} i^2 R_c dt \approx \int_0^{\pi/\omega} \left( 4 \frac{2}{\pi} \times \frac{(V_s - v_{o/p})}{R_c} \times \sin \omega_o t \right)^2 R_c dt \\ &= \frac{8}{\pi \omega_o R_c} (V_s - v_{o/p})^2 \end{aligned} \quad (21.11)$$

The relationship between the output voltage  $v_{o/p}$  and H-bridge switching frequency,  $\omega_s$ , is not a simple linear function. Because of the L-C series filter cut-off frequency  $\omega_s \approx \omega_o$ , only fundamental current flows as a result of the fundamental of the square-wave  $V_{H-B}$ , which has a magnitude of  $\frac{4}{\pi} V_s$  and an rms value of  $\frac{2\sqrt{2}}{\pi} V_s$ . A series R-C-L ac circuit at frequency  $\omega_s$  can be used to derive a relationship between the output voltage  $v_{o/p}$  and  $\omega_s$ .

The effective ac load resistance for a series L-C resonant circuit, from equation (21.7) becomes  $R_{eq} = \frac{8}{\pi^2} R_{load} = \frac{8}{\pi^2} (V/I)$  such that Kirchhoff's voltage law for the series circuit in figure 21.2a, is

$$\begin{aligned} \frac{4}{\pi} V_s &= i \times \left( R_{eq} + R_c + j \left( \omega_s L_r - \frac{1}{\omega_s C_r} \right) \right) = i \times (R_{eq} + R_c + j(X_L - X_C)) \\ \frac{4}{\pi} v_{o/p} &= i \times R_{eq} \end{aligned} \quad (21.12)$$

The equivalent output voltage is therefore given by

$$v_o(\omega_s) = V_s \times \frac{R_{eq}}{R_{eq} + R_c + j \left( \omega_s L_r - \frac{1}{\omega_s C_r} \right)} \quad (21.13)$$

where the H-bridge switching frequency is  $\omega_s = 2\pi f_s$ .

Figure 21.2 shows equation (21.13) for different circuit Q. The plot can be used to extract output voltage  $v_{o/p}$  and H-bridge switching frequency. The output voltage is scaled to eliminate the coil resistance component  $R_c$  from the total resistive voltage.

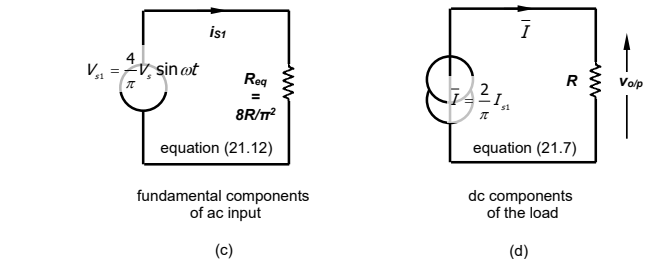
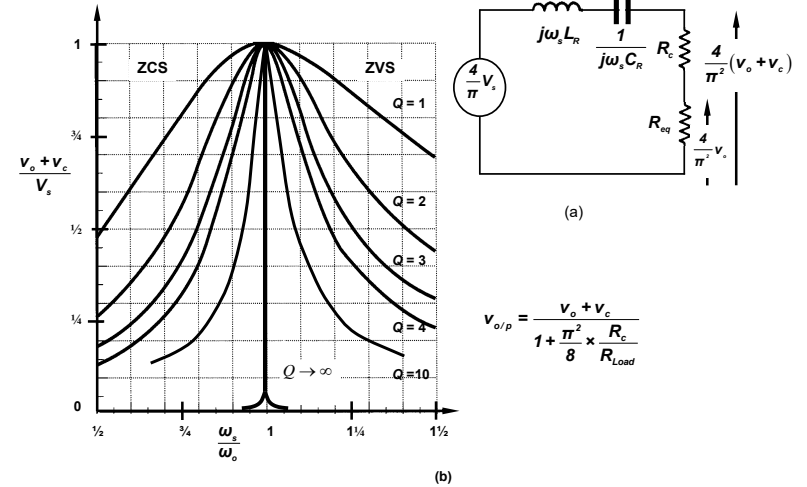

Figure 21.2. Series resonant converter SRC: (a) equivalent circuit; (b) normalised output voltage curves; (c) input ac equivalent circuit; and (d) load dc equivalent circuit.

Ignoring coil resistance, the voltage transfer function is

$$\frac{V_o(\omega)}{V_s} = \frac{R_{eq}}{R_{eq} + j\left(\omega L_R - \frac{1}{\omega C_R}\right)} = \frac{1}{1 + jQ\left(\frac{\omega}{\omega_o} - \frac{\omega_o}{\omega}\right)} = \frac{1}{1 + jQV}$$

$$\left|\frac{V_o(\omega)}{V_s}\right| = \frac{1}{\sqrt{1 + Q^2V^2}} \leq 1; \quad \psi = -\tan^{-1} QV \quad V = \frac{\omega}{\omega_o} - \frac{\omega_o}{\omega}$$
(21.14)

At  $f = f_o$ , which is the condition for maximum voltage gain, the input magnitude equals the output magnitude. When  $f < f_o$ , angle  $\psi$  is positive, and the output voltage, whence output current, leads the input voltage, meaning the load is capacitive. For  $f > f_o$ ,  $\psi$  is negative, and the output voltage, whence output current, lags the input voltage, meaning the load is inductive, as indicated in figure 21.3.

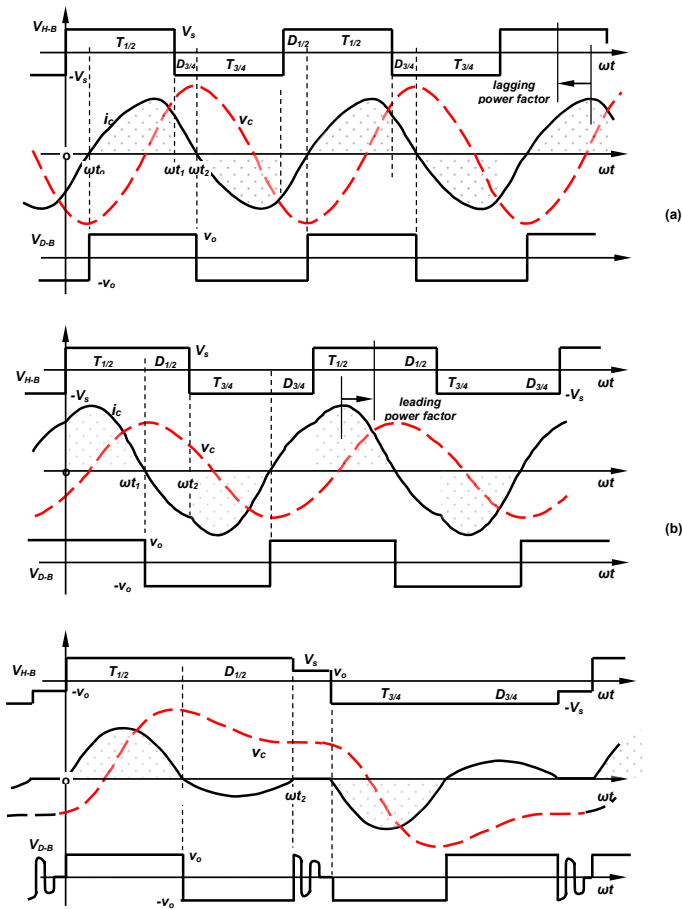

Figure 21.3. Three modes of series load resonant converter operation: (a)  $f_s > f_o$ ; (b)  $1/2f_o < f_s < f_o$ ; and (c)  $f_s < 1/2f_o$ .

### 21.1.1 Modes of operation - series resonant circuit

The basic series converter can be operated in any of three difference modes, depending on the switching frequency  $f_s$  in relation to the  $L-C$  circuit natural resonant frequency  $f_o$ . In all cases, the controlled output voltage is less than the input voltage, that is  $V_s - v_{o/p} \geq 0$ . The switching frequency involves one complete symmetrical square-wave output cycle from the inverter bridge,  $V_{H-B}$ . Waveforms for the three operational modes are shown in figure 21.3.

i.  $f_s < 1/2f_o$  :- discontinuous inductor current (switch conduction  $1/2f_s \leq t_r \leq 1/f_s$ )

If the switching frequency is less than half the  $L-C$  circuit natural resonant frequency, as shown in figure 21.3c, then discontinuous inductor current results. This is because once one complete  $L-C$  resonant ac cycle occurs and current stops - being unable to reverse, since the switches are turned off when the diodes conduct and the capacitor voltage is less than  $V_s + v_o$ . Turn-off occurs at zero current. Subsequent turn-on occurs at zero current but the voltage is determined by the voltage retained by the capacitor. Thyristors are therefore applicable switches in this mode of operation. The freewheel diodes turn on and off with zero current. Since the capacitor current rectified provides the load current average current, the H-bridge switching frequency controls the output voltage. Therefore at low switching frequencies, relative to the resonance frequency, the peak resonant current will be relatively high.

ii.  $1/2f_o < f_s < f_o$  :- continuous inductor current – leading power factor

If the switching frequency is just less than natural resonant frequency, as shown in figure 21.3b, such that turn-on occurs after half an oscillation cycle but before the completion of an ac oscillation cycle, continuous inductor current results. Switch turn-on occurs with finite inductor current and voltage conditions, with the diodes freewheeling. Diode reverse recovery losses occur and noise is injected into the circuit at voltage recovery snap. Fast recovery diodes are therefore necessary. Switch turn-off occurs at zero voltage and current, when the inductor current passes through zero and the freewheel diodes take up conduction. Thyristors are applicable as switching devices with this mode of control.

iii.  $f_s > f_o$  :- continuous inductor current – lagging power factor

If switch turn-off occurs before the resonance of half a resonant cycle is complete, as shown in figure 21.3a, continuous inductor current flows, hard switching results, and commutable switches must be used. Switch turn-on occurs at zero voltage and current hence no diode recovery snap occurs. This zero electrical condition turn-on allows lossless turn-off snubbers to be employed (a capacitor in parallel with each switch, or in parallel with any one switch in each leg).

For continuous inductor conduction, under light load conditions, resonant energy is continuously transferred to the output stage, which tends to progressively overcharge the output voltage towards the input voltage level,  $V_s$ . The charging progressively decreases as the supply voltage  $V_s$  is backed off by the increasing output voltage. That is  $V_s - v_{o/p}$  shown in figure 21.1c tends to zero such that the effective square-wave input is reduced to zero, as will the input energy.

### 21.1.2 Circuit variations

The number of semiconductors can be reduced by using a split dc rail as in figure 21.4a, at the expense of halving the bridge output voltage swing  $V_{H-B}$  to  $\pm 1/2V_s$ . The maximum dc output voltage is  $v_o \leq 1/2V_s$ . Although the number of semiconductors is halved, the already poor switch utilisation associated with any resonant converter, is further decreased. The switches and diodes support  $V_s$ . In the full-bridge case the corresponding switch and diode voltages are also both  $V_s$ .

Voltage and impedance matching, for example voltage step-up, can be obtained by using a high-frequency transformer coupled circuit as shown in figures 21.4b and c. When a transformer is used as in figure 21.4c, a centre tapped secondary can reduce the number of high frequency rectifying diodes from four to two, but diode reverse voltage rating is doubled from  $V_{D-B}$  to  $2V_{D-B}$ . Secondary copper winding utilisation is halved.

A further modification to any series converter is to use the resonant capacitor to form a split dc rail as shown in figure 21.4c, where each capacitance is  $1/2C_R$ . In ac terms the resonant capacitors are in parallel, with one charging while the other discharges, and visa versa, such that their voltage sums to  $V_s$ .

No rectifier output inductance filtering should be used because the series resonant circuit is acting in a current sourcing mode. The rectified output only need be capacitively filtered.

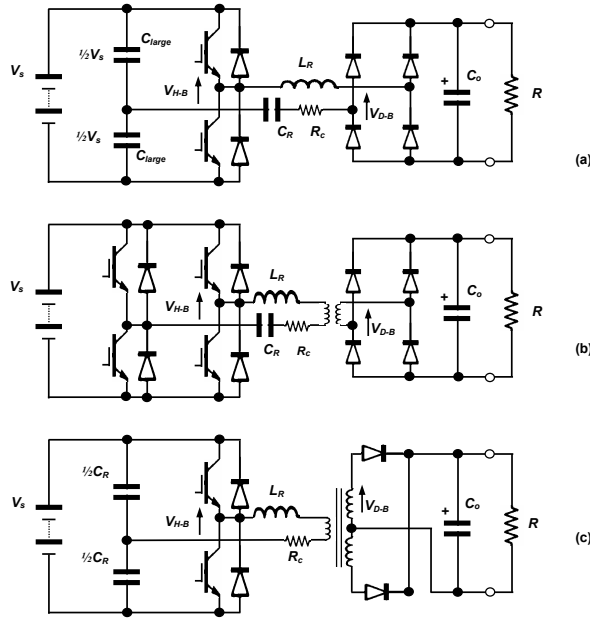

Figure 21.4. Series load resonant converters variations: (a) half bridge, split dc supply rail; (b) transformer couple full bridge; and (c) split resonant polarised capacitor, with a centre tapped output rectifier stage.

**21.2 Parallel-loaded series-resonant dc to dc converters**

The basic parallel load series resonant dc to dc converter is shown in figure 21.5a and its equivalent circuit is shown in figure 21.5b. The inductor  $L_o$  in the rectified output circuit produces a near constant current. A key feature is that the output voltage  $v_{o/p}$  can be greater than the input voltage  $V_s$ , that is  $0 \leq v_{o/p} \leq V_s$ . The capacitor voltage and inductor current equations for the equivalent circuit in figure 21.5b, for a constant current load  $I_o$ , and high circuit Q, are

$$i_L(t) = I_o + (i_{L0} - I_o) \cos \omega_o t + \frac{V_s - v_{c0}}{Z_o} \sin \omega_o t$$

$$= I_o + \frac{V_s}{Z_o} \sin \omega_o t \quad \text{for } v_{c0} = 0 \text{ and } i_{L0} = I_o$$

$$(21.15)$$

$$v_c(t) = V_s - (V_s - v_{c0}) \cos \omega_o t + Z_o (i_{L0} - I_o) \sin \omega_o t$$

$$= V_s (1 - \cos \omega_o t) \quad \text{for } v_{c0} = 0 \text{ and } i_{L0} = I_o$$

$$(21.16)$$

The relationship between the output voltage and the bridge switching frequency can be determined from the equivalent circuit shown in figure 21.5c where the output resistance has been replaced by its equivalent resistance related to the H-bridge output fundamental frequency magnitude,  $V_{H-B} = \frac{1}{\sqrt{2}} V_s$ . The voltage across the resonant capacitor  $C_R$  is assumed to be sinusoidal. Kirchhoff analysis of the equivalent circuit in figure 21.5b gives

$$\left| \frac{V_o}{V_s} \right| = \frac{8}{\pi^2} \times \left| \frac{1}{1 - \frac{X_L}{X_C} + j \frac{X_L}{R_{eq}}} \right| = \frac{8}{\pi^2} \times \frac{1}{\sqrt{\left(1 - \frac{\omega^2}{\omega_o^2}\right)^2 + j \frac{8}{\pi^2} \frac{1}{Q} \frac{\omega}{\omega_o}}} = \frac{8}{\pi^2} \times \frac{1}{\sqrt{\left(1 - \frac{X_L}{X_C}\right)^2 + \left(\frac{X_L}{R_{eq}}\right)^2}} \quad (21.17)$$

where the load resistance  $R$  is related to the equivalent ac resistance, at the switching frequency  $\omega_s$ , by  $R_{eq} = \frac{\pi^2}{8} \times R$ , for the parallel resonant load circuit. Series stray non-load resistance, which reduces the circuit Q ( $=R/\omega_o L_R$ ), has been neglected. The current gain is the voltage gain (0 to  $\infty$ ) divided by the Q.

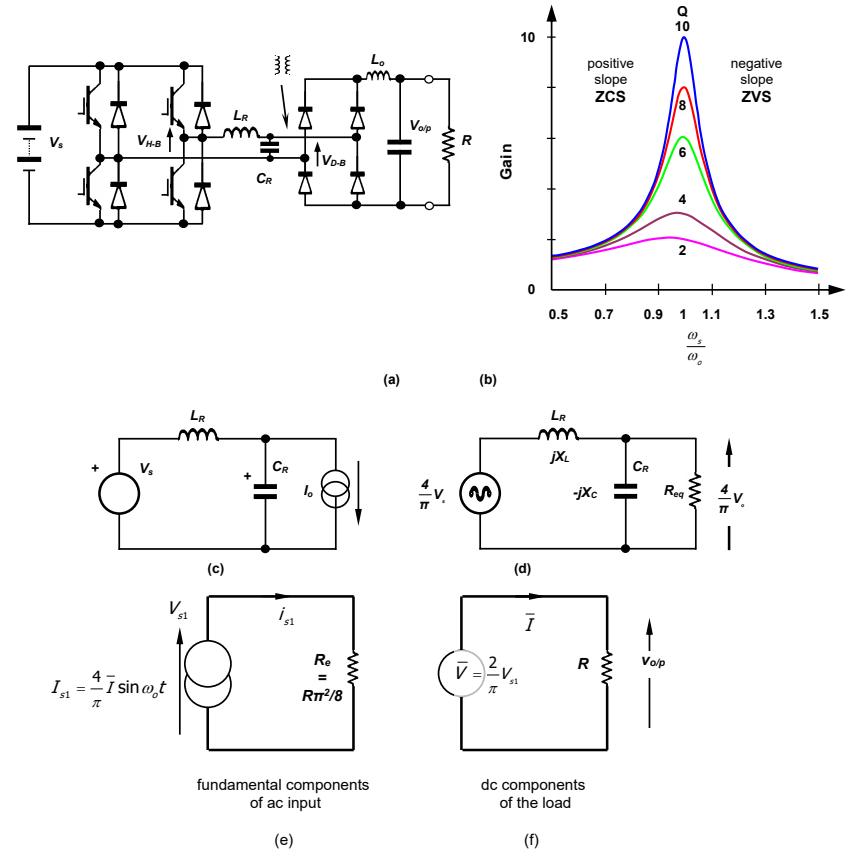

Figure 21.5. Parallel resonant dc to dc converter PRC: (a) circuit; (b) dc characteristics; (c) equivalent ac circuit; (d) equivalent fundamental input voltage circuit; (e) input ac equivalent circuit; and (f) load dc equivalent circuit.

**21.2.1 Modes of operation - parallel resonant circuit**

Three modes of operation are applicable to the parallel-resonant circuit, dc to dc converter, and waveforms are shown in figure 21.6.

i.  $f_s < \frac{1}{2} f_o$  :- discontinuous inductor current (switch conduction  $1/2f_o \leq t \leq 1/f_o$ ) Initially all switches are off and the load current energy stored in  $L_o$  freewheels through the output bridge diodes.

Both the inductor current and capacitor voltage are zero at the beginning of the cycle and at the end of the cycle. Thus switch turn-on and turn-off occur with zero current losses. At H-bridge turn-on the resonant inductor current increases linearly according to  $i = V_s t / L_R$  until the output current level  $I_o$  is reached at time  $t_r = L_R I_o / V_s$ , when the capacitor is free to resonant. The capacitor voltage is given by  $v_c(t) = V_s (1 - \cos \omega_o t)$  (21.18)

while the inductor current is given by

$$i_L(t) = I_o + \frac{V_s}{Z_o} \sin(\omega_o t) \quad (21.19)$$

The resonant circuit inductor current reverses as the on-switch antiparallel freewheel diodes conduct, at which time the switches may be turned off with zero current and voltage conditions. Any further inductor current reversal is therefore not possible. At the attempted reversal instant, any retained capacitor charge is discharged at a constant rate  $I_o$  into the inductor  $L_o$ . The capacitor voltage falls linearly to zero at which time the current in  $L_o$  freewheels in the output rectifier diodes.

ii.  $\frac{1}{2}f_o < f_s < f_o$  :- continuous inductor current – leading power factor  
 When switching below resonance, the switches commute naturally at turn-off, as shown in figure 21.6b, making thyristors a possibility.  
 Hard turn-on results, necessitating the use of fast recovery diodes.

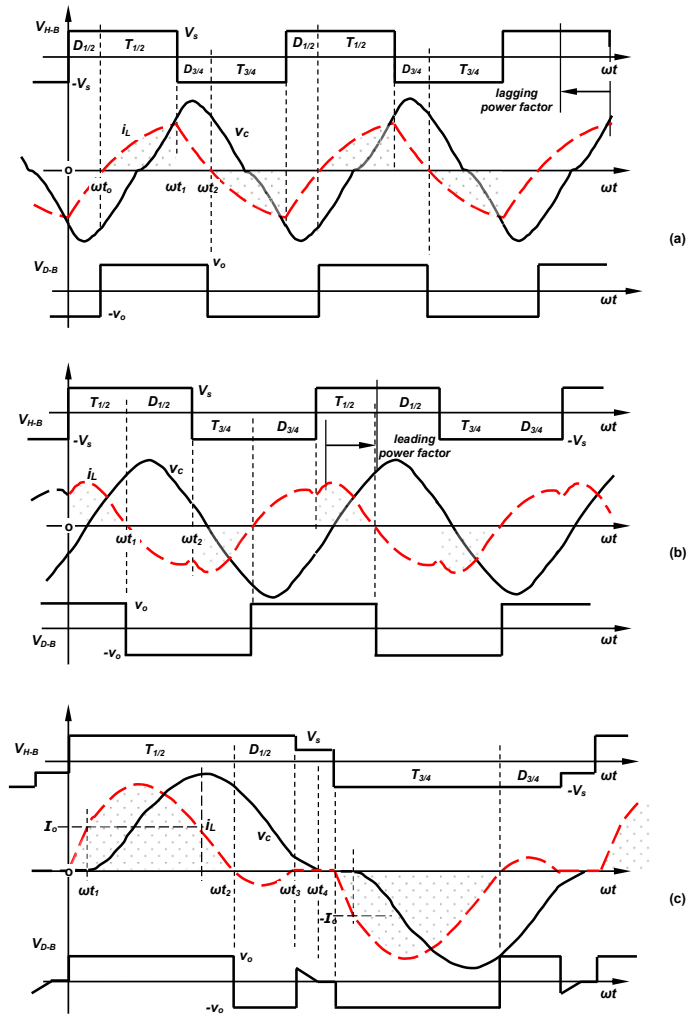

Figure 21.6. Three modes of parallel load resonant converter operation: (a)  $f_s > f_o$ ; (b)  $\frac{1}{2}f_o < f_s < f_o$ ; and (c)  $f_s < \frac{1}{2}f_o$ .

iii.  $f_s > f_o$  :- continuous inductor current – lagging power factor  
 When switching at frequencies above the natural resonance frequency, no turn-on losses result since turn-on occurs when a switches antiparallel diode is conducting. Turn-off occurs with inductor current flowing, hence hard turn-off results, with switch current commutated to a freewheel diode. In mitigation, lossless capacitive turn-off snubber can be used (a capacitor in parallel with each switch).

21.2.2 Circuit variations

A parallel resonant circuit approach, with or without transformer coupling, can also be used as indicated in figure 21.5a. The centre tapped secondary approach shown in figure 21.4c is also applicable. A dc capacitor split dc rail can also be used, as shown for the series load resonant circuit in figure 21.4a. In each case the constant current inductor  $L_o$  is in the rectified output circuit, which is voltage sourced.

21.3 Series-parallel load resonant dc to dc converters

Three passive element, parallel plus series, resonant circuits can be employed as shown in figures 21.7a and 21.8a, which attempt to combine to best features of series and parallel resonant tank circuits. The main limitation eliminated is the high no-load circulating current associated with parallel resonance.

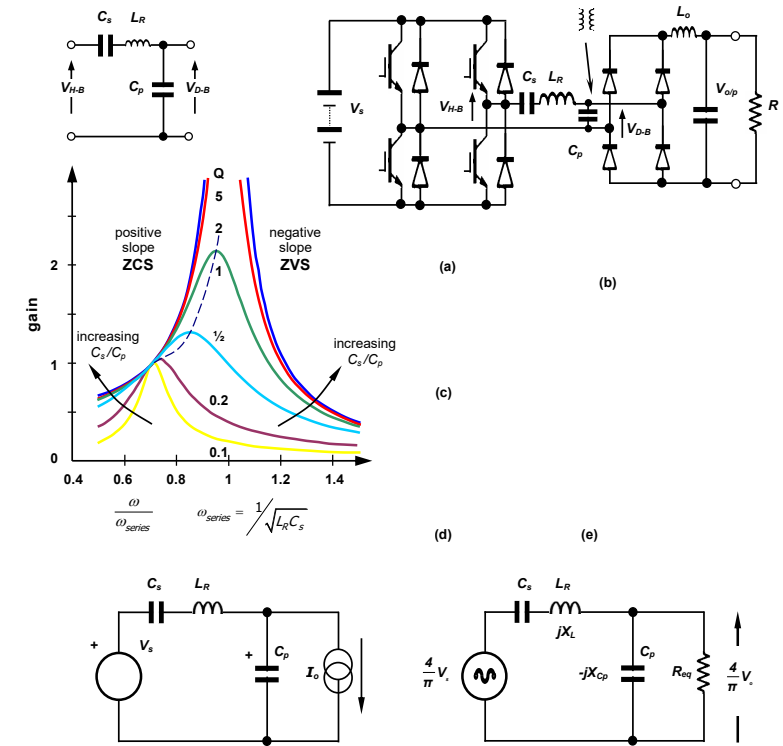

Figure 21.7. Series-parallel LCC resonant dc to dc converter: (a) basic series-parallel resonant circuit; (b) series-parallel load resonant converter circuit; (c) dc characteristics; (d) equivalent ac circuit; and (e) equivalent fundamental input voltage circuit.

21.3.1 LLC resonant tank circuit

A further load resonant converter variation is a combined series-parallel (third order) resonant stage as shown in figure 21.7a and the implemented circuit is figure 21.7b. This resonant approach combines the properties of the series and the parallel resonant approaches. Analysis is based on the same assumptions as for the parallel resonant cases, namely the H-bridge produces a square-wave voltage  $V_{H,B}$  at a frequency near the filter resonance frequency  $f_0$  which results in a near sinusoidal voltage across the parallel resonance capacitor  $C_p$ . The voltage across the parallel output capacitor is rectified by the output bridge rectifier, while the bridge output inductor, under steady state conditions, ensures near constant load current  $I_o$ .

Figure 21.7d shows the converter equivalent circuit, while figure 21.7e shows the ac equivalent circuit where it is assumed that the bridge square-wave frequency, which is its fundamental frequency, is near the resonant frequency. The ac equivalent resistance is the same as for the parallel resonant case, namely

$$R_{eq} = \frac{\pi^2}{8} R \tag{21.20}$$

In this case, the voltage transfer ratio, in terms of the fundamental input component, is given by

$$\frac{V_o}{V_s} = \frac{8}{\pi^2} \times \frac{1}{\sqrt{\left(1 + \frac{C_p}{C_s} - \omega^2 L_R C_p\right)^2 + \left(\frac{8}{\pi^2 R}\right) \times \left(\omega L_R - \frac{1}{\omega C_s}\right)^2}} \tag{21.21}$$

The magnitude of the dc to ac voltage transfer function is

$$\left| \frac{V_o}{V_s} \right| = \frac{1}{\sqrt{\left(1 + \lambda\right)^2 \left(1 - \left(\frac{\omega}{\omega_o}\right)^2\right)^2 + \frac{1}{Q^2} \times \left(\frac{\omega}{\omega_o} - \frac{\omega_o}{\omega} \frac{\lambda}{1 + \lambda}\right)^2}} \tag{21.22}$$

where  $\lambda = C_s/C_p$ .

At light and no-load, the operating point tends to the resonant peak at the upper resonant frequency

$$\omega_{o2}^2 = \frac{1}{L_R} \left( \frac{1}{C_p} + \frac{1}{C_s} \right) = \frac{1}{L_R} \frac{1}{C_{equiv}} = \frac{C_p + C_s}{L_R C_p C_s} \tag{21.23}$$

The lower resonant frequency is  $\omega_{o1}^2 = 1/L_R C_s$

All the circuit variations applicable to the parallel resonant circuit are also applicable to the series – parallel resonant converter. Additional advantage can be gained by the fact that a series resonant capacitor can be used to form the ac split dc rail arrangement shown in figure 21.4c.

21.3.2 LLC resonant tank circuit

The inductive elements in the tank circuit shown in figure 21.8a form the leakage inductance and magnetising inductance when the load is transformer coupled. The circuit is less sensitive to load changes than series resonant circuits and has lower circulating current under light and no-load conditions, than parallel resonant circuits. Two resonant frequencies occur

$$f_{o1} = \frac{1}{2\pi\sqrt{L_R C_R}} \text{ and } f_{o2} = \frac{1}{2\pi\sqrt{(L_p + L_R) C_R}} = f_{o1} \sqrt{\frac{\lambda}{\lambda + 1}} \tag{21.24}$$

The voltage transfer function is approximately (expression is correct at resonance)

$$\frac{V_{o/p}}{V_s} = \frac{j\omega \frac{L_p}{L_s}}{j\omega \left(\frac{L_p}{L_s} + 1 - \frac{1}{\omega^2}\right) + \frac{L_p}{L_s} (1 - \omega^2) \frac{Z}{R_{dc}} \frac{\pi^2}{8}} = \frac{1}{\left(1 + \lambda - \frac{\lambda}{\omega^2}\right) - j \frac{(1 - \omega^2)}{\omega} \frac{Z}{R_{dc}} \frac{\pi^2}{8}} \tag{21.25}$$

where  $Z = \sqrt{\frac{L_s}{C_s}}$ ,  $R_{eq} = \frac{8}{\pi^2} R_{dc}$ ,  $\lambda = \frac{L_R}{L_p}$ , and  $\omega = \omega_s / \omega_o$  is the normalised switching frequency. Then

$$\left| \frac{V_{o/p}}{V_s} \right| = \frac{1}{\sqrt{\left(1 + \lambda - \frac{\lambda}{\omega^2}\right)^2 + \left(\frac{1 - \omega^2}{\omega}\right)^2 \left(\frac{Z}{R_{dc}} \frac{\pi^2}{8}\right)^2}} = \frac{1}{\sqrt{\left(1 + \lambda - \frac{\lambda}{\omega^2}\right)^2 + Q^2 \left(\frac{1 - \omega^2}{\omega}\right)^2}} \tag{21.26}$$

where  $Q = \frac{Z_o}{R_{eq}} = \frac{Z_o}{n^2 R_{eq}} = \frac{\pi^2 Z_o}{8\pi^2 R_{dc}} = \frac{\pi^2 Z_o P_{out}}{8\pi^2 V_{dc}^2}$ . A transformer is accounted for by the turns ratio  $n:1$  term  $n$ .

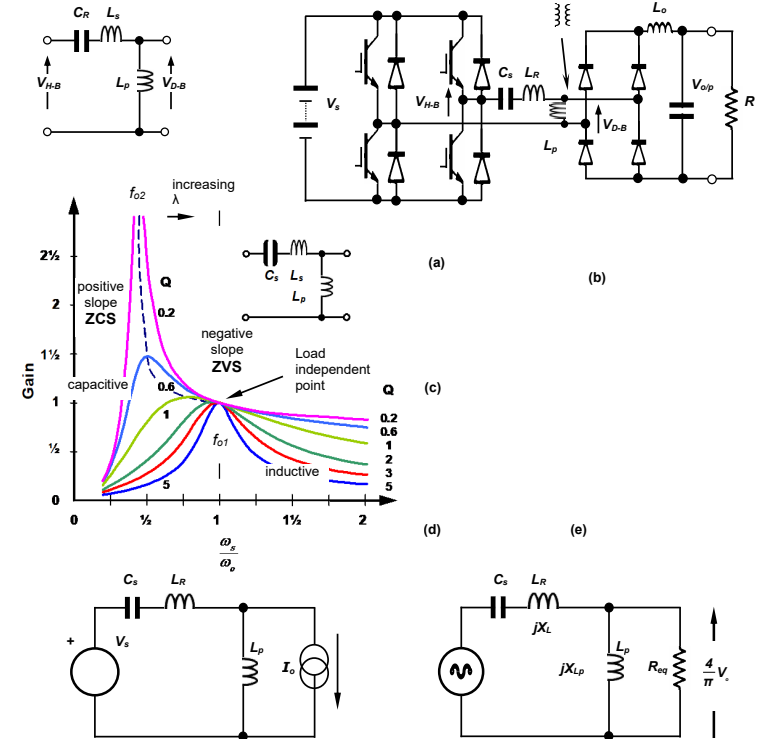

Figure 21.8. Series-parallel LLC resonant dc to dc converter: (a) basic series-parallel resonant circuit; (b) series-parallel load resonant converter circuit; (c) dc characteristics; (d) equivalent ac circuit; and (e) equivalent fundamental input voltage circuit.

The dc characteristic on the right of  $f_{o1}$  for the LLC converter are same characteristic as a SRC.

On the left of  $f_{o1}$ , the PRC and SRC characteristics emerge but oppose. At heavy loading, SRC characteristics dominant. At lighter loads, PRC characteristics dominate and the no load output magnitude, as Q tends to zero, is

$$\left| \frac{V_{o/p}}{V_s} \right| = \frac{1}{\left| 1 + \lambda - \frac{\lambda}{\omega^2} \right|} \tag{21.27}$$

By operating the LLC converter at a resonant frequency lower than that of a SRC, it retains a ZVS characteristic because PRC characteristics dominant in that frequency range.

Load resonant circuit comparison

The series-parallel approach combines the better switching properties of the series converter and the parallel converter, which are summarised in table 21.1. In common, a positive slope on the voltage transfer function versus frequency characteristics is associated with zero current switching ZCS, while a negative slope is indicative of zero voltage switching ZVS characteristics. Basically, the tank circuit is capacitive below resonance and becomes inductive above the resonance frequency.

Unlike the series converter, both the parallel and series-parallel converters can operate at zero load current, without output voltage over-charging. But advantageously, because of the LCC series input capacitor  $C_s$ , the efficiency at low power output levels is like that of the series converter, which is much higher than that of the series-parallel converter. The resonant currents with either parallel approach tend to be independent of the load.

**Series resonant converter SRC**

The resonant tank is in series with the load, hence the load is current sourced. The resonant tank and the load act as a voltage divider. By changing the frequency of input excitation voltage, the resonant tank impedance will change, which allows the load voltage to be varied. As a voltage divider, the SRC DC gain is always less than 1. At the resonant frequency, the maximum voltage gain frequency, the series resonant tank impedance is small; all the input voltage-fundamental-is developed across the load. An operating region on the right side of resonant frequency  $f_0$  is preferred because zero voltage switching (ZVS) is preferred for the LC series converter. When the switching frequency is below the resonant frequency, the converter operates with zero current switching (ZCS). When the DC gain slope is negative, the converter operates under a zero voltage switching condition. When the DC gain slope is positive, the converter switches under a zero current switching condition.

The voltage gain characteristics indicate that at light load, the switching frequency needs to increase, to reduce the gain, in order to maintain output voltage regulation. The main problems are: light load regulation, high circulating energy, and high turn-off current at high input voltage conditions.

**Parallel resonant converter PRC**

For the parallel resonant converter, the resonant LC tank is again a series LC circuit. It is called a parallel resonant converter because the load is in parallel with the resonant capacitor (or inductor). Technically this converter should be termed a series resonant converter with a parallel connected load. Compare with a SRC, the operating region is much smaller. At light load, the frequency is minimally changed to maintain output voltage regulation. So light load regulation is not a problem with the PRC. For the PRC, circulating energy is high even at light load. Since the load is in parallel with the resonant capacitor, even at a no load condition, the input sees the impedance of the series resonant tank. This induces a high circulating energy even when the load is zero.

The main problems are: high circulating energy and high turn-off current at high input voltage conditions.

**Series-parallel resonant converter SPRC**

The resonant tank of a SPRC can be considered a combination of SRC and PRC converters, producing the best characteristics of each. With the load in series with series tank L and C, the circulating energy is smaller than with the PRC. With the parallel capacitor, the SPRC can regulate the output voltage at a no load condition, by operating at a frequency above resonance.

The operating region of the SPRC has a narrower switching frequency range with load change than the SRC. The input current in much smaller than that of the PRC and slightly larger than for the SRC. This means for the SPRC, the circulating energy is less than with the PRC.

A SPRC combines the better characteristics of a SRC and a PRC: smaller circulating energy and is not too sensitive to load change.

**Table 21.1: Switch and diode turn-on/turn-off conditions for resonant switch converters**

|                 | series load resonance |           | parallel load resonance |          |           | power factor |           |
|-----------------|-----------------------|-----------|-------------------------|----------|-----------|--------------|-----------|
|                 | switch on             | diode off | switch off              | diode on | switch on |              | diode off |
| $f_s < 1/2 f_0$ | ZCS                   | ZCS       | ZCS                     | ZCS      | ZCS       | ZCS          | N/A       |
| $f_s < f_0$     | hard*                 | ZCS       | ZCS                     | hard*    | ZCS       | ZCS          | leading   |
| $f_s > f_0$     | ZCS                   | ZVS       | hard*                   | ZCS      | ZCS       | ZVS          | lagging   |

Lossless, \* capacitive turn-off or \* inductive turn-on snubbers can be used, as appropriate

**21.4 Resonant coupled-load configurations**

The concept of voltage and current transformer coupling is introduced. A series LC resonant circuit produces a resonant sinusoidal current and anti-phased sinusoidal voltages across both the circuit L and C components. A current transformer can therefore be used in series with the resonant circuit, while, alternatively a voltage transformer can be used in parallel with either the series circuit L or C elements.

In the case of a parallel transformer resonant circuit, a voltage transformer is used across the resonant capacitor (or inductor) as shown in figure 21.9b, while for a series transformer resonant circuit, a current transformer is used in series with the resonant circuit inductor and capacitor, as shown in figure 21.9a.

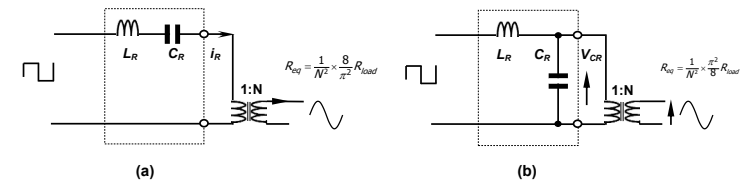

Figure 21.9. Voltage-source transformer resonant converter circuits: (a) series transformer LC resonant circuit and (b) parallel transformer LC resonant circuit.

In series, as shown in figure 21.9a, the primary current is a controlled sinusoid, hence by Ampere-turns transformer action, the secondary is a current source sinusoidal waveform. The secondary current is faithfully delivered into any voltage. This mode of transformer action is therefore termed 'current' transformer operation since the transformer primary is driven to obey  $I_{prim} = N \times I_{sec}$ . However, the secondary circuit must have low series inductance, since the secondary is driven by a current source.

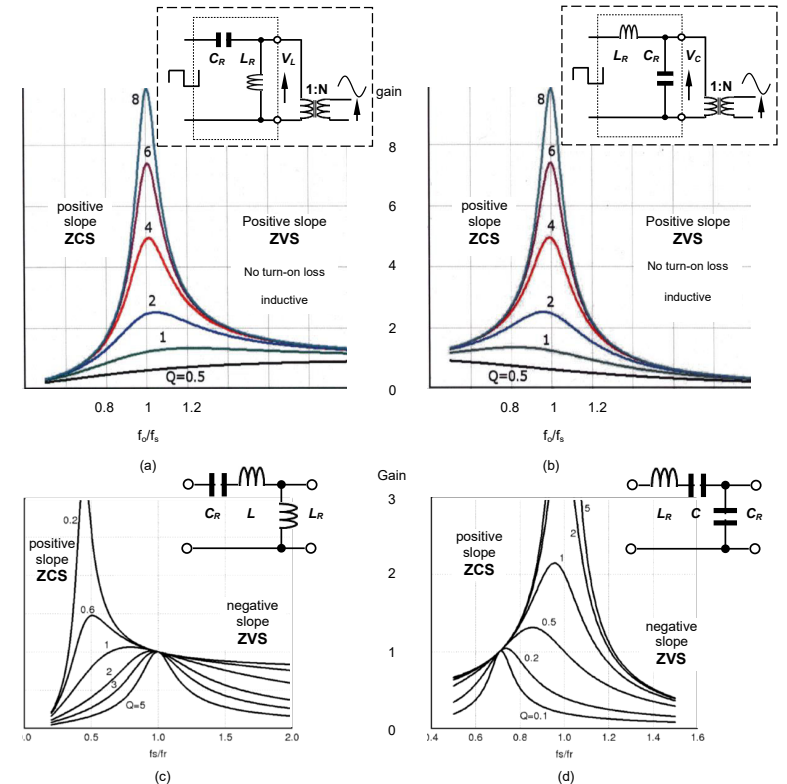

Figure 21.10. Voltage transformer coupled, resonant converter circuits, LC, LLC, LCC: (a) and (c) parallel resonant inductor  $L_R$  transformer coupling circuits and (b) and (d) parallel resonant capacitor  $C_R$  transformer coupling circuit.



A voltage coupling transformer requires a voltage source, so the voltage across the capacitor  $C_R$  (or alternatively inductor  $L_R$ ) of a series resonant circuit can be utilised as shown in figure 21.9b and figure 21.10. The primary voltage is controlled by the capacitor  $C_R$  voltage, as is the secondary voltage when complying with  $V_{sec} = N \times V_{prim}$ . Although the voltage is faithfully reproduced on the secondary, the secondary current, hence primary current, are determined by the secondary load circuit. A transformer used in this mode is termed a 'voltage' transformer. However, in order to prevent uncontrolled secondary currents, the secondary inductor,  $L_o$ , in figures 21.5, 21.7 and 21.8, is introduced to give controlled output current source properties.

The advantage of the parallel transformer resonant circuit over the series approach is that the turns ratio of the transformer can be reduced (increased primary turns for a given output specification) because of the higher gain (greater than unity) of parallel-coupled resonant circuits (see figures 21.2b and 21.5b). For example, if the circuit Q is four, the transformer turns ratio can be decreased by a similar factor over that needed for a series transformer resonance circuit.

Both the parallel transformer coupled circuits in figure 21.10 can take advantage of inherent voltage gain in order to reduce the necessary transformer turns ratio. Figure 21.10 shows that the voltage transformer can be parallel coupled to the inductor, as in figure 21.10a, or the capacitor, as in figure 21.10b. At resonance, the two circuits behave identically. The off-resonance characteristics are different (opposite), particular at frequencies above resonance, where ZVS and inductive operation occur in both cases. Above resonance, the inductor supports an increasing amount of the H-bridge output ac voltage as the capacitor reactance, hence voltage and output gain diminish to zero in figure 21.10b, but the output is unity in figure 21.10a. The ability to reduce the gain to near zero, with ZVS, is important at converter start-up, and enables the start-up current inrush into any output capacitor to be better controlled. The inductance of the output inductor  $L_o$  can thereby be minimised.

#### Example 21.1: Transformer-coupled, series-resonant, dc to dc converter

The series resonant dc step-down voltage converter in figure 21.1a is operated at just above the resonant frequency of the load circuit and is used with a step up transformer, 1:2 ( $n_T = 1/2$ ), as shown in figure 21.4a. It produces an output voltage for the armature of a high voltage dc motor that has a voltage requirement that is greater than the 50Hz ac mains rectified, 340V dc, with an L-C dc link filter. The resonant circuit parameters are  $L_R = 100\mu\text{H}$ ,  $C_R = 0.47\mu\text{F}$ , and the coil resistance is  $R_c = 1\Omega$ . For a 10Ω armature resistance,  $R_{load}$ , calculate

- the circuit Q and  $\omega_o$
- the output voltage, hence dc armature current and power delivered
- the secondary circuit dc filter capacitor voltage and rms current rating
- the resonant circuit rms ac current and capacitor rms ac voltage
- the converter average input current and efficiency
- the ac current in the input L-C dc rectifier filter decoupling capacitor
- the H-bridge square-wave switching frequency  $\omega_s$ , greater than  $\omega_o$ .

#### Solution

- i. The resonant circuit Q is

$$Q = \frac{L_R}{C_R} / R_c = \frac{100\mu\text{H}}{0.47\mu\text{F}} / 1\Omega = 14.6$$

For this high Q, the circuit resonant frequency and damped frequency will be almost the same, that is

$$\begin{aligned} \omega &\approx \omega_o = 1 / \sqrt{L_R C_R} \\ &= 1 / \sqrt{100\mu\text{H} \times 0.47\mu\text{F}} = 146 \text{ krad/s} \\ &= 2\pi f \\ f &= 146 \text{ krad/s} / 2\pi = 23.25 \text{ kHz} \end{aligned}$$

- ii. From equation (21.7), which will be accurate because of a high circuit Q of 14.6,

$$\begin{aligned} \bar{I} &= \frac{2}{\pi} \hat{I} = \frac{8}{\pi^2} \frac{(V_s - n_T \times V_{o/p})}{R_c} = \frac{8}{\pi^2} \times \frac{(340 \text{ V} - 1/2 V_{o/p})}{1\Omega} \\ &= 0.81 \times (340 \text{ V} - 1/2 V_{o/p}) \end{aligned}$$

Note that the output voltage  $V_{o/p}$  across the dc decoupling capacitor has been referred to the primary by  $n_T$ , hence halved, due to the turns ratio of 1:2.

The rectified resonant current provides the load current, that is

$$\bar{I} = \frac{1}{n_T} \times \frac{V_{o/p}}{R_{load}} = 2 \times \frac{V_{o/p}}{10\Omega} = \frac{V_{o/p}}{5}$$

Again the secondary current has been referred to the primary. Solving the two average primary current equations gives

$$\begin{aligned} \bar{I} &= 0.81 \times (340 - 1/2 V_{o/p}) = \frac{V_{o/p}}{5} \\ V_{o/p} &= 456 \text{ V and } \bar{I} = 91.2 \text{ A} \end{aligned}$$

That is, the load voltage is 456V dc and the load current is  $456\text{V}/10\Omega = 91.2\text{A}/2 = 45.6\text{A}$  dc. The power delivered to the load is  $456^2/10\Omega = 20.8\text{kW}$ .

- iii. From part ii, the capacitor dc voltage requirement is at least 456V dc. The secondary rms current is

$$\begin{aligned} I_{Srms} &= n_T \times I_{Prms} = n_T \times \frac{1}{\sqrt{2}} \times \hat{I}_p = 1/2 \times \frac{1}{\sqrt{2}} \times \frac{\pi}{2} \times \bar{I}_p \\ &= 0.555 \times \bar{I}_p = 0.555 \times 91.2 \text{ A} \\ &= 50.65 \text{ A rms} \end{aligned}$$

The primary rms current is double the secondary rms current, 101.3A rms.

By Kirchhoff's current law, the secondary current (50.65A rms) splits between the load (45.6A dc) and the decoupling capacitor. That is the rms current in the capacitor is

$$I_{C rms} = \sqrt{I_{S rms}^2 - I_s^2} = \sqrt{50.65\text{A}^2 - 45.6\text{A}^2} = 22 \text{ A rms}$$

That is, the secondary dc filter capacitor has a dc voltage requirement of 456V dc and a current requirement of 22A rms at 46.5kHz, which is double the resonant frequency because of the rectification process.

- iv. The primary rms current is double the secondary rms current, namely from part iii,  $I_{Prms} = 101.3\text{A}$  rms (essentially 101.3A at 23.25kHz). The 0.47μF resonant capacitor voltage is given by

$$\begin{aligned} V_{cap} &= I_{Prms} X_c = \frac{I_{Prms}}{\omega_o C_R} \\ &= \frac{101.3\text{A}}{146\text{krad/s} \times 0.47\mu\text{F}} = 1476 \text{ V rms (predominately at 23.25kHz)} \end{aligned}$$

The resonant circuit capacitor has an rms current rating requirement of 101.3A rms and an rms voltage rating of 1476 V rms.

- v. From part ii, the average input current is 91.2 A. The supply input power is therefore  $340\text{Vdc} \times 91.2\text{A}$  ave = 31kW. The power dissipated in the resonant circuit resistance  $R_c = 1\Omega$  is given by  $I_{Prms}^2 \times R_c = 101.3^2 \times 1\Omega = 10.26\text{kW}$ . The coil power plus the load power (from part ii) equals the input power ( $20.8\text{kW} + 10.26\text{kW} = 31\text{kW}$ ). The efficiency is

$$\begin{aligned} \eta &= \frac{\text{output power}}{\text{input power}} \times 100\% \\ &= \frac{20.8\text{kW}}{31\text{kW}} \times 100 = 67.1\%. \end{aligned}$$

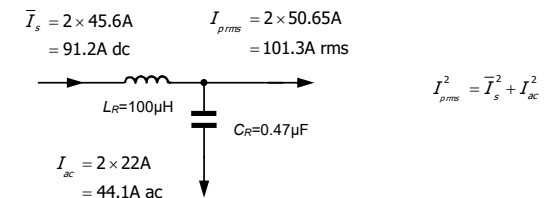

- vi. The average input dc current is 91.2A dc while the resonant bridge rms current is 101.3A rms. By Kirchhoff's current law, the 340V dc rail decoupling capacitor ac current is given by

$$\begin{aligned} I_{ac} &= \sqrt{I_{Prms}^2 - I_{Pave}^2} \\ &= \sqrt{101.3^2 - 91.2^2} = 44.1 \text{ A ac} \end{aligned}$$

This is the same ac current magnitude as the current in the dc capacitor across the load in the secondary circuit, 22A, when the transformer turns ratio, 2, is taken into account.



vii. The voltage across the load resistance is given by equation (21.13)

$$\frac{V_o}{V_s} = \frac{R_{eq}}{R_{eq} + R_c + j\left(\omega_s L_R - \frac{1}{\omega_s C_R}\right)} = \frac{\frac{8}{\pi^2} \times n_T^2 \times R_{Load}}{\frac{8}{\pi^2} \times n_T^2 \times R_{Load} + R_c + j\left(\omega_s L_R - \frac{1}{\omega_s C_R}\right)}$$

$$\frac{228V}{340V} = \left| \frac{\frac{8}{\pi^2} \times \frac{1}{4} \times 10\Omega}{\frac{8}{\pi^2} \times \frac{1}{4} \times 10\Omega + 1\Omega + j\left(\omega_s 100\mu H - \frac{1}{\omega_s 0.47\mu F}\right)} \right|$$

which yields  $\omega_s \approx \omega_o = 146\text{krad/s}$ .

Because of the high circuit  $Q = 14.6$ , but an infinite  $Q$  being assumed to evaluate  $v_o$ , and relatively high voltage transfer ratio  $V_o/V_s = 0.66$ ,  $\omega_s$  is very close to  $\omega_o$ , as can be deduced from the plots in figure 21.2b. The output voltage control will be very sensitive to changes in the H-bridge switching frequency.

**21.5 Resonant-switch, dc to dc step-down voltage converters**

There are two forms of resonant switch circuit configurations for dc to dc converters, namely resonant voltage and resonant current switch commutation. Each type reduces the switching losses to near zero. The technique can be used on any hard switch circuit, for example, resonant switching is applicable to the switch in the buck, boost, buck/boost, Cuk, Sepic, Zeta, etc. converters.

- In *resonant current commutation* the switch current is reduced to zero by an *L-C resonant circuit* current greater in magnitude than the load current, such that the switch is turned on and off with zero current.
- In *resonant voltage commutation* the switch voltage is reduced to zero by the capacitor of an *L-C resonant circuit* with a voltage magnitude greater than the output voltage, such that the switch can turn on and off with zero voltage.

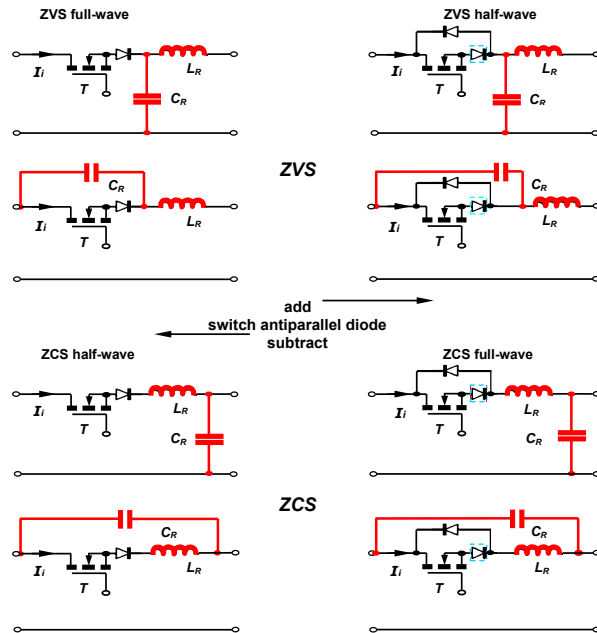

Figure 21.11. Resonant switches, showing half-wave and full-wave circuits for both ZCS and ZVS.

Both full-wave or half-wave resonance switching is possible, depending on whether half a resonant cycle or a full resonant cycle is allowed by the circuit configuration. Figure 21.11 shows the basic resonant switch building blocks. A common feature, with a dc voltage source, is that the resonant inductor  $L_R$  is in series with the switch to be losslessly commutated. Essentially a diode across the switch determines whether full or half-wave commutation can occur. In the case of ZCS, the anti-parallel diode allows the resonant current to continue for a full ac resonant cycle, while the same diode prevents a full resonant capacitor voltage cycle since the diode clamps any switch negative voltage to zero.

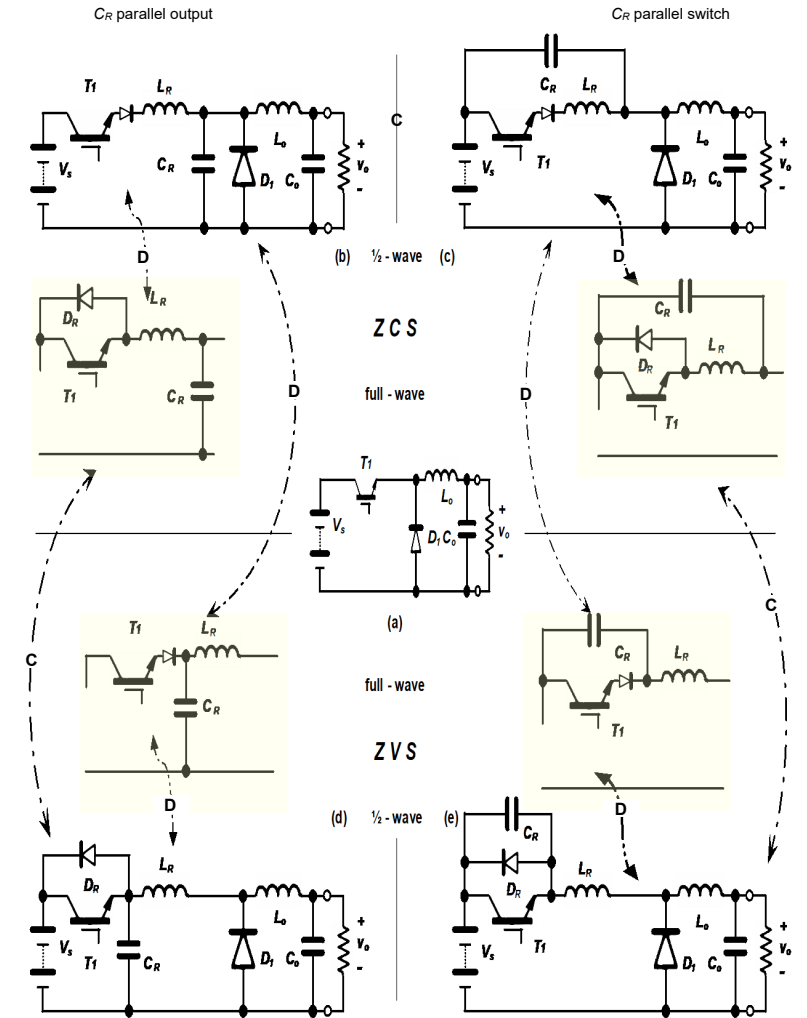

Figure 21.12. DC to dc resonant switch step-down converters: (a) conventional switch mode forward step-down converter; (b) and (c) half-wave zero current switching ZCS resonant switch converters; and (d) and (e) half-wave zero voltage switching ZVS resonant switch converters. Topological translations between half-wave and full-wave versions also shown.

Although resonant switching is applicable to boost and buck/boost converters, only its application to the buck converter will be specifically analysed. In mitigation, the basic resonant switch possibilities for the buck, boost, and buck/boost converters are shown in matrix form, in the figures 21.22, 21.23, and 21.24 of the Appendix 21.7 at the end of this chapter.

Figure 21.12a shows the basic single switch, forward, step-down voltage switch mode dc to dc converter. Resonant switch forward converters are an extension of the standard switch mode forward converter, but the switch is supplement with passive components  $L_R - C_R$  to provide resonant operation through the switch, hence facilitating zero current or voltage switching. Common to each circuit is a resonant inductor  $L_R$  in series with the switch to be commutated. Parasitic series inductance is therefore not an issue with most resonant switch converters.

An important operational requirement is that the average load current never falls to zero, otherwise the resonant capacitor  $C_R$  can never fully discharge in order to fulfil its zero switch voltage/current electrical condition function.

The resonant capacitor  $C_R$ , can be either in a parallel or series arrangement as shown in figure 21.12, since small-signal ac-wise, thence resonance wise, the connections are the same. A well-decoupled supply is essential when the capacitor  $C_R$  is used in the parallel switch arrangement, as shown in figure 21.12d. A further restriction shown in figure 21.12, is that a diode must be used in series or in anti-parallel with T1 if a switch without reverse blocking capability is used.

The use of a diode  $D_R$  in anti-parallel to the switch (shown shaded below figures 21.12 b and c) changes the switching arrangement from half-wave resonant to full-wave resonant operation, where switch reverse voltage block capability is not necessary.

Conversely, removal of the diode  $D_R$  in figures 21.12 d and e (shown shaded above figures 21.12 d and e) changes the switching arrangement from half-wave resonant to full-wave resonant operation, where switch reverse voltage block capability is necessary.

Reconnecting the capacitor  $C_R$  terminal not associated with  $V_s$ , to the other end of inductor  $L_R$  in the half-wave circuit in figures 21.12b-e, will create four full-wave resonant switch circuits, with the commutation type, namely ZVS or ZCS, interchanged.

Full and half-wave operation is dependent on whether the circuit configuration allows the resonant capacitor to complete a full or half resonant sinusoidal cycle.

Table 21.2: ZCS and ZVS circuit characteristics

| Characteristics and properties |        |                              | ZVS<br>no turn-off loss<br>constant off-time |                       | ZCS<br>no turn-on loss<br>constant on-time |                            |
|--------------------------------|--------|------------------------------|--|-----------------------|--|----------------------------|
| type                           | period |                              | $I_{cap}$                                    | switch                | $V_{cap}$                                  | switch                     |
| half-wave                      | $\pi$  | $\frac{1}{2}$ resonant cycle | current resonates                            | anti-parallel diode   | voltage resonates                          | reverse blocking           |
| full-wave                      | $2\pi$ | 1 resonant cycle             | current resonates                            | reverse blocking      | voltage resonates                          | anti-parallel diode        |
|                                |        |                              | controlled $di/dt$ 's                        | > twice the dc supply | controlled $dv/dt$ 's                      | > twice the output current |

21.5.1 Zero-current, resonant-switch, dc to dc converter -  $\frac{1}{2}$  wave,  $C_R$  parallel with load version

The zero current switching of T1 in figure 21.13 (21.12b) can be analysed in five distinctive stages, as shown in the capacitor voltage and inductor current waveforms in figure 21.13b. The switch is turned on at  $t_0$  and turned off after  $t_4$  but before  $t_5$ .

Assume the circuit has attained steady state load conditions from one cycle to the next. The cycle commences, before  $t_0$ , with both the capacitor voltage and inductor current being zero, and the load current is freewheeling through D1. The output inductor  $L_o$ , is large enough such that its current,  $I_o$  can be assumed constant. The switch T1 is off.

Time interval I

At  $t_0$  the switch is turned on and the series inductor  $L_R$  acts as a turn-on snubber for the switch. In the interval  $t_0$  to  $t_1$ , the supply voltage is impressed across  $L_R$  since the switch T1 is on and the diode D1 conducts the output current, thereby clamping the associated inductor terminal to zero volts. Because of the fixed voltage  $V_s$ , the current in  $L_R$  increases from zero, linearly to  $I_0$  in time

$$t_1 = I_o L_R / V_s \tag{21.28}$$

according to

$$i_{L_R}(t) = \frac{V_s}{L_R} t \tag{21.29}$$

During this interval, the resonant capacitor voltage is clamped to zero since  $C_R$  is in parallel with D1 which is conducting a current decreasing from  $I_0$  to zero:

$$v_c(t) = 0 \tag{21.30}$$

Time interval IIA

When the current in  $L_R$  reaches  $I_0$  at time  $t_1$ , the capacitor  $C_R$  and  $L_R$  are free to resonate. The diode D1 blocks as the voltage across  $C_R$  sinusoidally increases. The constant load current component in  $L_R$  does not influence its ac performance since a constant inductor current does not produce any inductor voltage. Its voltage is specified by the resonant cycle, provided  $I_o < V_s / Z_o$ . The capacitor resonantly charges to twice the supply  $V_s$  when the inductor current falls back to the load current level  $I_0$ , at time  $t_3$ .

Time interval IIB

Between times  $t_3$  and  $t_4$  the load current is displaced from  $L_R$  by charge from  $C_R$ , in a quasi resonance process. The resonant cycle cannot reverse through the switch once the inductor current reaches zero at time  $t_4$ , because of the series blocking diode (the switch must have uni-directional conduction characteristics).

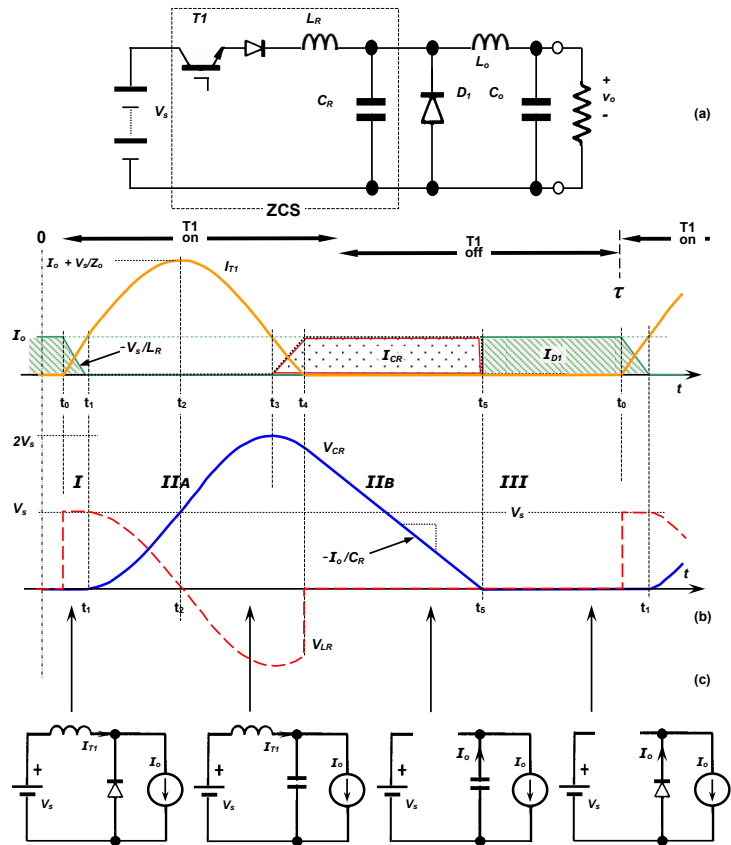

Figure 21.13. Zero current switching, ZCS, half-wave resonant switch dc to dc converter with the resonant capacitor across the output: (a) circuit; (b) waveforms; and (c) equivalent circuits.

The capacitor voltage and current for period *IIA* and approximately for period *IIB*, are given by equations 14.60 and 14.61 with the appropriate initial conditions of  $i_o = 0$  and  $v_o = 0$ :

$$v_c(\omega t) = V_s \left( 1 - \frac{\omega_o}{\omega} e^{-\omega t} \cos(\omega t - \phi) \right) \quad (21.31)$$

$$\approx V_s (1 - e^{-\omega t} \cos \omega t)$$

$$i_c(\omega t) = \frac{V_s}{\omega L} \times e^{-\omega t} \times \sin \omega t \quad (21.32)$$

If the circuit Q is high, these equations can be approximated by

$$v_{c_R}(t) = V_s (1 - \cos \omega_o t) \quad \text{where} \quad v_{c_R} = 2V_s \quad (21.33)$$

$$i_{c_R}(t) = \frac{V_s}{Z_o} \sin \omega_o t \quad (21.34)$$

The inductor current is the constant load current plus the capacitor current:

$$i_{L_R}(t) = I_o + i_{c_R}(t) = I_o + \frac{V_s}{Z_o} \sin \omega_o t \quad \text{where} \quad \hat{i}_{T1} = \hat{i}_{L_R} = I_o + \frac{V_s}{Z_o} \quad (21.35)$$

where  $Z_o = \sqrt{L_R/C_R}$  and  $\omega_o = 1/\sqrt{L_R C_R}$ . Equation (21.35) shows that the inductor current only returns to zero if  $I_o < V_s / Z_o$ , otherwise the switch is commutated with a non-zero current flow.

Setting  $i_L = 0$  in equation (21.35) gives the time for period *II* as

$$t_{II} = \left( \pi + \sin^{-1} \left( \frac{I_o Z_o}{V_s} \right) \right) / \omega_o \quad (21.36)$$

after which time the capacitor voltage and inductor current reach

$$V_{c_R t4} = V_s \left( 1 + \sqrt{1 - \left( \frac{I_o Z_o}{V_s} \right)^2} \right) \quad (21.37)$$

$$I_{L_R t4} = 0$$

#### Time interval III

At time  $t_4$  the input current is zero and the switch T1 can be turned off with zero current, ZCS. The constant load current requirement  $I_o$  is provided by the capacitor, which discharges linearly to zero volts at time  $t_5$  according to

$$v_{c_R}(t) = V_{c_R t4} - \frac{I_o}{C_R} \times t = V_s \left( 1 + \sqrt{1 - \left( \frac{I_o Z_o}{V_s} \right)^2} \right) - \frac{I_o}{C_R} \times t \quad (21.38)$$

where  $V_{c_R t4}$  is given by equation (21.37).

The inductor current is

$$i_{L_R}(t) = 0 \quad (21.39)$$

The time for interval *III* is load current dependant and is given by setting equation (21.38) to zero:

$$t_{III} = \frac{V_{c_R t4} C_R}{I_o} = \frac{C_R}{I_o} \times V_s \left( 1 + \sqrt{1 - \left( \frac{I_o Z_o}{V_s} \right)^2} \right) \quad (21.40)$$

#### Time interval IV

After  $t_5$ , the switch is off, the current freewheels through D1, the capacitor voltage is zero, and the input inductor current is zero. At time  $t_1$  the cycle recommences. The switch off-time, interval *IV*,  $t_5$  to the subsequent  $t_0$ , is used to control the rate at which energy is transferred to the load.

#### Output voltage

The output voltage can be specified by either evaluating the energy from the supply, through the input resonant inductor  $L_R$ , or by evaluating the average voltage across the resonant capacitor  $C_R$  (or the freewheel diode D1) which is filtered by the output filter  $L_o - C_o$ .

By considering the input inductor energy (volt-second integral) for each period shown in the waveforms in figure 21.13b, the output energy, whence voltage, is given by

$$v_o = \frac{V_s}{\tau} (\frac{1}{2} t_I + t_{II} + t_{III}) \quad (21.41)$$

$$= \frac{V_s}{\tau} \times \left[ \frac{1}{\omega_o} \left( \pi + \sin^{-1} \left( \frac{I_o Z_o}{V_s} \right) \right) + \frac{1}{2} \frac{I_o L_R}{V_s} + V_s \left( 1 + \sqrt{1 - \left( \frac{I_o Z_o}{V_s} \right)^2} \right) \times \frac{C_R}{I_o} \right]$$

where the time intervals *I*, *II*, and *III* are given by equations (21.28), (21.36), and (21.40) respectively, the switching frequency  $f_s = 1/\tau$ , and  $\tau > t_I + t_{II} + t_{III}$ .

The output voltage based on the average capacitor voltage (after resetting time zero references) is

$$v_o = \frac{1}{\tau} \left[ \int_0^{t_4-t_1} V_s (1 - \cos \omega t) dt + \int_0^{t_5-t_4} V_{c_R t4} \left( 1 - \frac{t}{t_5 - t_4} \right) dt \right] \quad (21.42)$$

$$= \frac{1}{\tau} \times \left[ \frac{V_s}{\omega_o} \left( \pi + \sin^{-1} \left( \frac{I_o Z_o}{V_s} \right) + \frac{I_o Z_o}{V_s} \right) + \frac{1}{2} \times V_s^2 \times \sqrt{1 - \left( \frac{I_o Z_o}{V_s} \right)^2} \times \left( 1 + \sqrt{1 - \left( \frac{I_o Z_o}{V_s} \right)^2} \right) \times \frac{C_R}{I_o} \right]$$

The output voltage in equation (21.42) reduces to equation (21.41).

The minimum switch commutation period is  $t_I + t_{II} + t_{III}$  which limits the upper operating frequency, hence maximum output voltage. The output voltage, which is less than the input voltage, is inversely related to the switching frequency.

The circuit has a number of features:

- Turn-on and turn-off occur at zero current, hence switching losses are minimal.
- Increasing the switch off period (interval *VI*) decreases the average output voltage.
- At light load currents, the switching frequency may become extreme low.
- The capacitor discharge time is  $t_{III} \leq V_{c_R t4} \times C_R / I_o$ , thus the output voltage is load current dependant.
- $L_R$  and  $C_R$  are dimensioned such that the capacitor voltage is greater than  $V_s$  at time  $t_4$ , at maximum load current  $I_o$ .
- Supply inductance is inconsequential, and decreases the inductance  $L_R$  requirement.
- Being based on the forward converter, the output voltage is less than the input voltage. The output increases with increased switching frequency.
- If a diode in antiparallel to the switch is added as shown below figure 21.12b, reverse inductor current can flow and the output voltage is  $v_o \approx V_s \times f_s / f_o$ . A full-wave resonant zero current switch circuit is formed.

#### 21.5.1i - Zero-current, full-wave resonant switch converter

By adding a diode in anti-parallel to the switch, as shown in figure 21.14 (and the circuit below figure 21.12b), resonant action can continue beyond  $\omega t \geq \pi$ .

Assume the circuit has attained steady state load conditions from one cycle to the next. The cycle commences, before  $t_0$ , with both the capacitor voltage and inductor current being zero, and the load current is freewheeling through D1. The output inductor  $L_o$ , is large enough such that its current,  $I_o$  can be assumed constant. The switch T1 is off.

#### Time interval I

At  $t_0$  the switch is turned on and the series inductor  $L_R$  acts as a turn-on snubber for the switch. In the interval  $t_0$  to  $t_1$ , the supply voltage is impressed across  $L_R$  since the switch T1 is on and the diode D1 conducts the output current, thereby clamping the associated inductor terminal to  $V_s$ . Because of the fixed voltage  $V_s$ , the current in  $L_R$  increases from zero, linearly to  $I_o$  in time

$$t_I = I_o L_R / V_s = \frac{1}{\omega_o} \frac{Z_o I_o}{V_s} \quad (21.43)$$

according to

$$i_{L_R}(t) = \frac{V_s}{L_R} t \quad (21.44)$$

and also  $i_{D1R}(t) = I_o - i_{L_R}(t) = I_o - \frac{V_s}{L_R} t$

During this interval the resonant capacitor voltage is clamped to  $-V_s$  (with respect to input voltage positive terminal) since  $C_R$  is in parallel with  $L_R$  which is conducting  $I_o$ :

$$V_c(t) = -V_s \tag{21.45}$$

**Time interval II**

When the current in  $L_R$  reaches  $I_o$  at time  $t_1$ , the capacitor  $C_R$  and  $L_R$  are free to resonate. The diode  $D_1$  blocks as the voltage across  $C_R$  sinusoidally decreases. The constant load current component in  $L_R$  does not influence its ac performance since a constant inductor current does not produce any inductor voltage. Its voltage is specified by the resonant cycle, provided  $I_o < V_s / Z_o$ . The capacitor resonantly charges to the opposite polarity  $+V_s$  when the inductor current falls back to the load current level  $I_o$ , at time  $t_2$ .

Between times  $t_3$  and  $t_4$  the load current is displaced from  $L_R$  by charge from  $C_R$  in a quasi resonance process. The resonant cycle reverses through the switch parallel diode  $D_R$  once the inductor current reaches zero at time  $t_4$ .

Assuming a high circuit Q, the capacitor voltage and inductor current for period II, are given by

$$V_{C_R}(t) = V_s(1 - \cos \omega_o t) \tag{21.46}$$

$$i_{L_R}(t) = I_o + i_{C_R}(t) = I_o + \frac{V}{Z_o} \sin \omega_o t \tag{21.47}$$

where  $Z_o = \sqrt{L_R / C_R}$  and  $\omega_o = 1 / \sqrt{L_R C_R}$ . Equation (21.47) shows that the inductor current only returns to zero if  $I_o < V_s / Z_o$ , otherwise the switch is commutated with non-zero current flow.

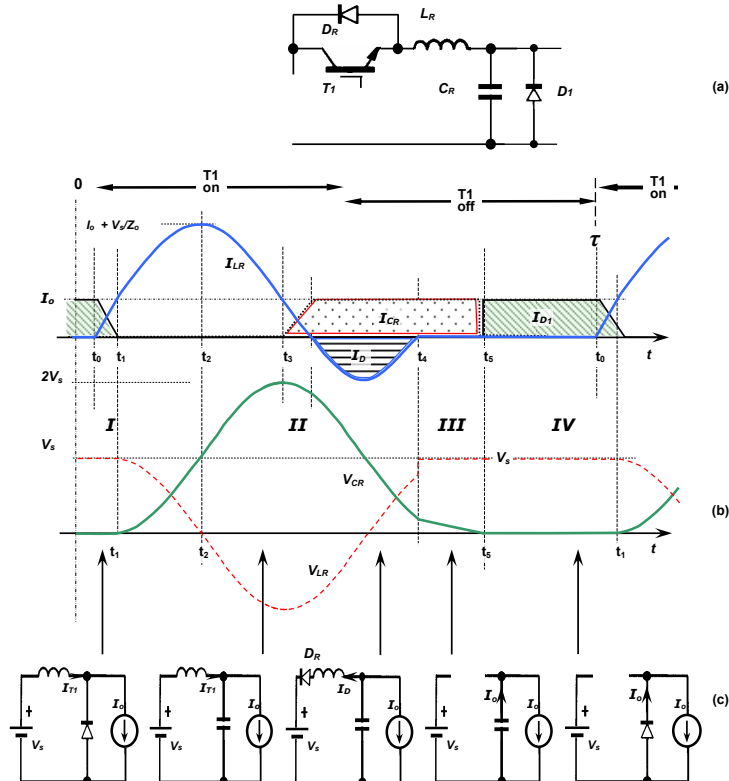

Figure 21.14. Zero current switching, ZCS, full-wave resonant switch dc to dc converter with the resonant capacitor across the output: (a) circuit; (b) waveforms; and (c) equivalent circuits.

The peak inductor current hence maximum switch current, from equation (21.47), is

$$\hat{i}_{T1} = \hat{i}_{L_R} = I_o + \frac{V_s}{Z_o} \tag{21.48}$$

By adding a diode in anti-parallel to the switch, resonant action can continue beyond  $\omega t \geq \pi$ .

The capacitor can resonant to a lower voltage level, hence the capacitor linear discharge period starts from a lower voltage, equation (21.49).

$$V_{C_R, t4} = V_s \left( 1 + \sqrt{1 - \left( \frac{I_o Z_o}{V_s} \right)^2} \right) \tag{21.49}$$

The lower limit of load current for proper circuit action is therefore decreased with full-wave resonant circuits. Equations (21.31) to (21.42) remain valid except the time for interval II is extended to the fourth quadrant where  $i_L = 0$  and the capacitor voltage at  $t_4$  is decreased. That is

$$t_{II} = \left( 2\pi - \sin^{-1} \left( \frac{I_o Z_o}{V_s} \right) \right) / \omega_o \tag{21.50}$$

**Time interval III**

Before time  $t_4$  the input current is zero and the switch T1 can be turned off with zero current, ZCS. The constant load current requirement  $I_o$  is provided by the capacitor, which discharges linearly to zero volts at time  $t_5$  according to

$$V_{C_R}(t) = V_{C_R, t4} - \frac{I_o}{C_R} \times t = V_s \left( 1 + \sqrt{1 - \left( \frac{I_o Z_o}{V_s} \right)^2} \right) - \frac{I_o}{C_R} \times t \tag{21.51}$$

where  $V_{C_R, t4}$  is given by equation (21.49).

The inductor current is

$$i_{L_R}(t) = 0 \tag{21.52}$$

The time for interval III is load current dependant and is given by setting equation (21.51) to 0:

$$t_{III} = \frac{V_{C_R, t4} C_R}{I_o} = \frac{C_R}{I_o} \times V_s \left( 1 + \sqrt{1 - \left( \frac{I_o Z_o}{V_s} \right)^2} \right) \tag{21.53}$$

**Time interval IV**

After  $t_5$ , the switch is off, the current freewheels through  $D_1$ , the capacitor voltage is zero, and the input inductor current is zero. At time  $t_6$  the cycle recommences. The switch off-time, interval IV,  $t_5$  to the subsequent  $t_6$ , is used to control the rate at which energy is transferred to the load.

**Output voltage**

Since switch turn-off is dependent on the resonant cycle, the output voltage does not depend on the duty cycle, but is resonant period depend according to

$$V_o = V_s \frac{2\pi \sqrt{L_R C_R}}{\tau} = V_s \frac{2\pi}{\omega_o \tau} \tag{21.54}$$

**21.5.2 Zero-current, resonant-switch, dc to dc converter - 1/2 wave,  $C_R$  parallel with switch version**

Operation of the ZCS circuit in figure 21.15 (figure 21.12c), where the capacitor  $C_R$  is connected in parallel with the switch, is essentially the same as the circuit in figure 21.13. The capacitor connection produces the result that the capacitor voltage has a dc offset of  $V_s$ , meaning its voltage swings between  $\pm V_s$  rather than zero and twice  $V_s$ , as in the circuit in figure 21.13.

The zero current switching of T1 in figure 21.15 is analysed in five distinctive stages, as shown in the capacitor voltage and inductor current waveforms in figure 21.15b. The switch is turned on at  $t_0$  and turned off after  $t_4$  but before  $t_5$ .

Assume the circuit has attained steady state load conditions from one cycle to the next. The cycle commences, before  $t_0$ , with the inductor current being zero, the capacitor charged to  $V_s$  with the polarity shown, and the load current freewheeling through  $D_1$ . The output inductor  $L_o$ , is large enough such that its current,  $I_o$  can be assumed constant. The switch T1 is off.

**Time interval I**

At  $t_0$  the switch is turned on and the series inductor  $L_R$  acts as a turn-on snubber for the switch. In the interval  $t_0$  to  $t_1$ , the supply voltage is impressed across  $L_R$  since the switch T1 is on and diode  $D_1$

conducts the output current, thereby clamping the associated inductor terminal to  $V_s$ . Because of the fixed voltage  $V_s$ , the current in  $L_R$  increases from zero, linearly to  $I_o$  in time

$$t_I = I_o L_R / V_s = \frac{1}{\omega_o} \frac{Z_o I_o}{V_s} \tag{21.55}$$

according to

$$i_{L_R}(t) = \frac{V_s}{L_R} t \tag{21.56}$$

During this interval the resonant capacitor voltage is clamped to  $-V_s$  (with respect to input voltage positive terminal) since  $C_R$  is in parallel with  $L_R$  which is conducting  $I_o$ :

$$V_C(t) = -V_s \tag{21.57}$$

**Time interval II**

When the current in  $L_R$  reaches  $I_o$  at time  $t_1$ , the capacitor  $C_R$  and  $L_R$  are free to resonate. The diode D1 blocks as the voltage across  $C_R$  sinusoidally decreases. The constant load current component in  $L_R$  does not influence its ac performance since a constant inductor current does not produce any inductor voltage. Its voltage is specified by the resonant cycle, provided  $I_o < V_s / Z_o$ . The capacitor resonantly charges to the opposite polarity  $+V_s$  when the inductor current falls back to the load current level  $I_o$ , at time  $t_3$ .

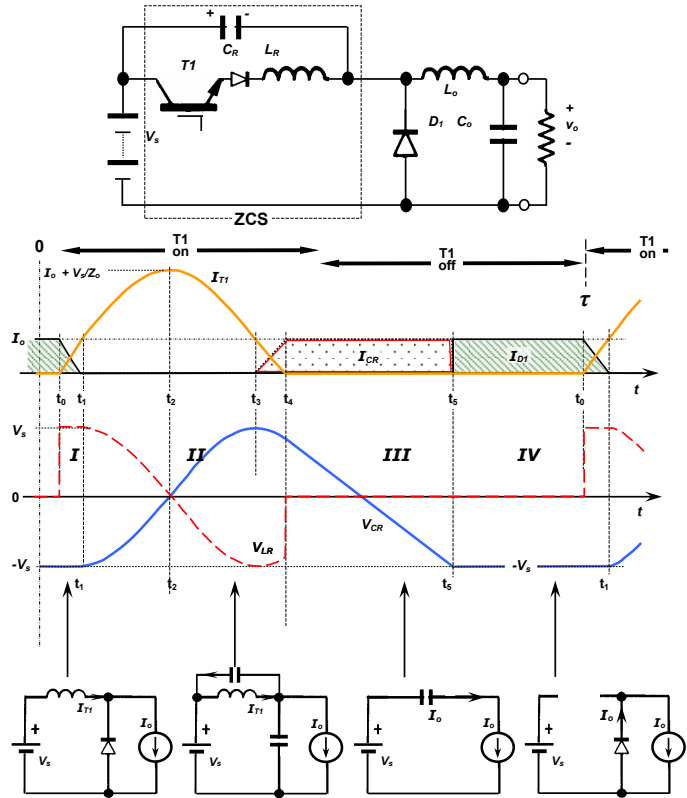

Figure 21.15. Zero current switching, ZCS, half-wave resonant switch dc to dc converter with resonant capacitor across the switch: (a) circuit; (b) waveforms; and (c) equivalent circuits.

Between times  $t_3$  and  $t_4$  the load current is displaced from  $L_R$  by charge from  $C_R$ , in a quasi resonance process. The resonant cycle cannot reverse through the switch once the inductor current reaches zero at time  $t_4$ , because of the series blocking diode (the switch must have uni-directional conduction characteristics).

Assuming a high circuit Q, the capacitor voltage and inductor current for period II, are given by

$$V_{C_R}(t) = -V_s \cos \omega_o t \tag{21.58}$$

$$i_L(t) = I_o + i_{C_R}(t) = I_o + \frac{V_s}{Z_o} \sin \omega_o t \tag{21.59}$$

where  $Z_o = \sqrt{L_R / C_R}$  and  $\omega_o = 1 / \sqrt{L_R C_R}$ . Equation (21.59) shows that the inductor current only returns to zero if  $I_o < V_s / Z_o$ , otherwise the switch is commutated with non-zero current flow.

Setting  $i_L = 0$  in equation (21.59) gives the time for period II as

$$t_{II} = \left( \pi + \sin^{-1} \left( \frac{I_o Z_o}{V_s} \right) \right) / \omega_o \tag{21.60}$$

at which time the capacitor voltage and inductor current are

$$V_{C_R t4} = V_s \sqrt{1 - \left( \frac{I_o Z_o}{V_s} \right)^2} \tag{21.61}$$

$$I_{L_R t4} = 0$$

**Time interval III**

At time  $t_4$  the input current is zero and the switch T1 can be turned off with zero current, ZCS. The constant load current requirement  $I_o$  is provided by the capacitor, which discharges linearly to  $-V_s$  volts at time  $t_5$  according to

$$V_{C_R}(t) = V_{C_R t4} - \frac{I_o}{C_R} \times t = V_s \sqrt{1 - \left( \frac{I_o Z_o}{V_s} \right)^2} - \frac{I_o}{C_R} \times t \tag{21.62}$$

where  $V_{C_R t4}$  is given by equation (21.61).

The inductor current is

$$i_{L_R}(t) = 0 \tag{21.63}$$

The time for interval III is load current dependant and is given by setting equation (21.62) to  $-V_s$ :

$$t_{III} = \frac{V_{C_R t4} C_R}{I_o} = \frac{C_R}{I_o} \times V_s \left( 1 + \sqrt{1 - \left( \frac{I_o Z_o}{V_s} \right)^2} \right) \tag{21.64}$$

**Time interval IV**

After  $t_5$ , the switch is off, the current freewheels through D1, the capacitor voltage is  $-V_s$ , and the input inductor current is zero. At time  $t_1$  the cycle recommences. The switch off-time, interval IV,  $t_5$  to the subsequent  $t_0$ , is used to control the rate at which energy is transferred to the load.

**Output voltage**

By considering the input inductor energy (volt-second integral) for each period shown in the waveforms in figure 21.15b, the output energy, whence voltage, is given by

$$V_o = \frac{V_s}{\tau} (\frac{1}{2} t_I + t_{II} + t_{III}) \tag{21.65}$$

$$= \frac{V_s}{\tau} \times \left( \frac{1}{\omega_o} \left( \pi + \sin^{-1} \left( \frac{I_o Z_o}{V_s} \right) \right) + \frac{1}{2} \frac{I_o L_R}{V_s} + V_s \left( 1 + \sqrt{1 - \left( \frac{I_o Z_o}{V_s} \right)^2} \right) \times \frac{C_R}{I_o} \right)$$

where the time intervals I, II, and III are given by equations (21.55), (21.60), and (21.64) respectively, the switching frequency  $f_s = 1 / \tau$ , and  $\tau > t_I + t_{II} + t_{III}$ .

The output voltage based on the average diode voltage (after resetting time zero references) is

$$V_o = \frac{1}{\tau} \left[ \int_0^{t_4-t_1} V_s (1 - \cos \omega t) dt + \int_0^{t_5-t_4} V_{C_R t4} \left( 1 - \frac{t}{t_5-t_4} \right) dt \right] \tag{21.66}$$

$$= \frac{1}{\tau} \times \left[ \frac{V_s}{\omega_o} \left( \pi + \sin^{-1} \left( \frac{I_o Z_o}{V_s} \right) + \frac{I_o Z_o}{V_s} \right) + \frac{1}{2} \times V_s^2 \times \sqrt{1 - \left( \frac{I_o Z_o}{V_s} \right)^2} \times \left( 1 + \sqrt{1 - \left( \frac{I_o Z_o}{V_s} \right)^2} \right) \times \frac{C_R}{I_o} \right]$$

The output voltage in equation (21.66) reduces to equation (21.65).

**21.5.3 Zero-voltage, resonant-switch, dc to dc converter - 1/2 wave, C<sub>R</sub> parallel with switch version**

The zero voltage switching of T1 in figure 21.16 (21.12e) can be analysed in four distinctive stages, as shown in the resonant capacitor voltage and inductor current waveforms. The switch is turned off at t<sub>0</sub> and turned on after t<sub>4</sub> but before t<sub>5</sub>.

The circuit has attained steady state load conditions from one cycle to the next. The cycle commences, before t<sub>0</sub>, with the capacitor C<sub>R</sub> voltage being zero and the load current I<sub>o</sub> being conducted by the switch and the resonant inductor, L<sub>R</sub>. The output inductor L<sub>o</sub> is large enough such that its current, I<sub>o</sub> can be assumed constant. The switch T1 is on.

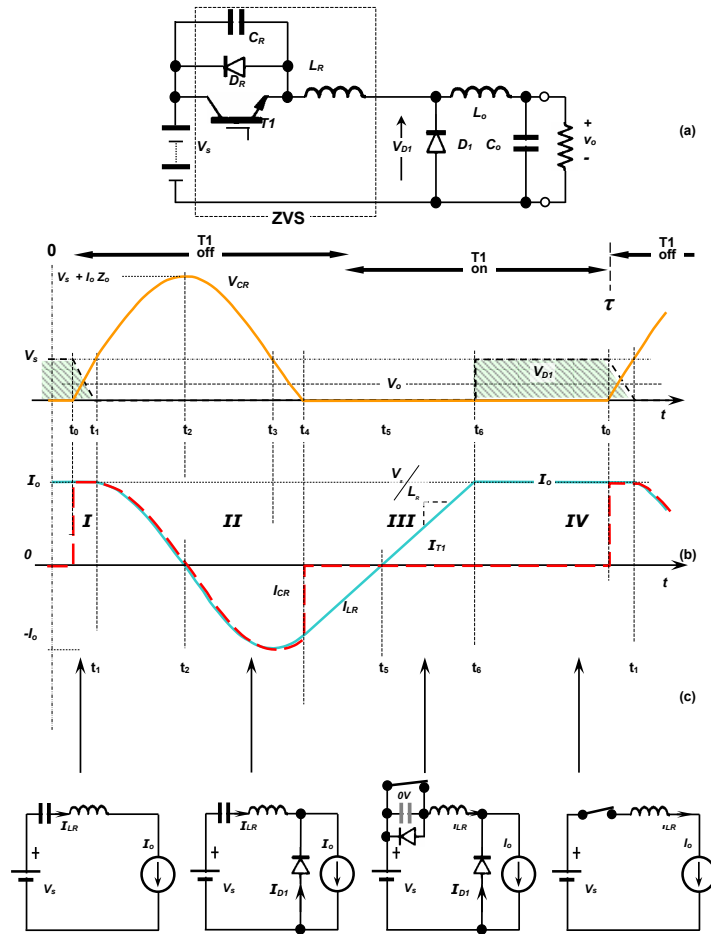

Figure 21.16. Zero voltage switching, ZVS, half-wave, resonant switch dc to dc converter: (a) circuit; (b) waveforms; and (c) equivalents circuits.

**Time interval I**

At time t<sub>0</sub> the switch is turned off and the parallel capacitor C<sub>R</sub> acts as a turn-off snubber for the switch. In the interval t<sub>0</sub> to t<sub>1</sub>, the supply current is provided from V<sub>s</sub> through C<sub>R</sub> and L<sub>R</sub>. Because the load current is constant, I<sub>o</sub>, due to large L<sub>o</sub>, the capacitor charges linearly from 0V until its voltage reaches V<sub>s</sub> in time

$$t_1 = \frac{V_s C_R}{I_o} = \frac{V_s}{I_o \omega_o Z_o} \tag{21.67}$$

where  $Z_o = \sqrt{\frac{L_R}{C_R}}$  and  $\omega_o = \sqrt{L_R C_R}$

according to

$$v_c(t) = \frac{I_o}{C_R} \times t = V_s \times \frac{t}{t_1} \tag{21.68}$$

The inductor current is zero, that is

$$i_{LR}(t) = 0 \tag{21.69}$$

The freewheel diode voltage, which is related to the output voltage, is given by

$$V_{D1} = V_s - v_c = V_s - \frac{I_o}{C_R} \times t = V_s \times \left(1 - \frac{t}{t_1}\right) \tag{21.70}$$

**Time interval II**

When the voltage across C<sub>R</sub> reaches V<sub>s</sub> at time t<sub>1</sub>, (equation (21.67)), the load freewheel diode conducts, clamping the load voltage to zero volts. The capacitor C<sub>R</sub> and L<sub>R</sub> are free to resonate, where the initial inductor current is I<sub>o</sub> and the initial capacitor voltage is V<sub>s</sub>. The energy in the inductor transfers to the capacitor, which increases its voltage from V<sub>s</sub> to a maximum, at time t<sub>2</sub>, of

$$V_c = V_s + I_o Z_o \tag{21.71}$$

The capacitor energy transfers back to the inductor which has resonated from + I<sub>o</sub> to - I<sub>o</sub> between times t<sub>1</sub> to time t<sub>3</sub>. For the capacitor voltage to resonantly return to zero, I<sub>o</sub> > V<sub>s</sub> / Z<sub>o</sub>. Between t<sub>3</sub> and t<sub>4</sub> the voltage V<sub>s</sub> on C<sub>R</sub> is resonated through L<sub>R</sub>, which conducts - I<sub>o</sub> at t<sub>3</sub>, as part of the resonance process. Assuming a high circuit Q, the resonant capacitor voltage and inductor current during period II are given by

$$v_{CR}(t) = V_s + I_o Z_o \sin \omega_o t \tag{21.72}$$

$$i_{LR}(t) = I_o \cos \omega_o t$$

and the duration of interval II is

$$t_{II} = \left(\pi + \sin^{-1} \frac{V_s}{I_o Z_o}\right) / \omega_o \tag{21.73}$$

At the end of interval II the capacitor voltage is zero and the inductor and capacitor currents are

$$i_{CR}(t_4) = i_{LR}(t_4) = I_o \cos \omega_o t_{II} = -I_o \sqrt{1 - \left(\frac{V_s}{I_o Z_o}\right)} \tag{21.74}$$

and

$$v_{CR}(t_{II}) = 0 \tag{21.75}$$

The freewheel diode current at the end of interval II is

$$i_{D1}(t_4) = I_o + I_o \sqrt{1 - \left(\frac{V_s}{I_o Z_o}\right)} \tag{21.76}$$

**Time interval III**

At time t<sub>4</sub> the voltage on C<sub>R</sub> attempts to reverse, but is clamped to zero by diode D<sub>R</sub>. The inductor energy is returned to the supply V<sub>s</sub> via diode D<sub>R</sub> and the freewheel diode D<sub>1</sub>. The inductor current decreases linearly to zero during the period t<sub>4</sub> to t<sub>5</sub>. **During this period, the switch T1 is turned on.**

No turn-on losses occur because the diode D<sub>R</sub> in parallel with T1 is conducting during the period the switch is turned on, that is, the switch voltage is zero and the switch T1 can be turned on with zero voltage, ZVS. With the switch on at time t<sub>5</sub> the current in the inductor L<sub>R</sub> reverses and builds up, linearly to I<sub>o</sub> at time t<sub>6</sub>. The current slope is supply V<sub>s</sub> dependant, according to V<sub>s</sub> = L<sub>R</sub> di/dt, that is

$$i_{LR}(t) = i_{DR}(t) = \frac{V_s}{L_R} t + I_o \cos \omega_o t_{II} \tag{21.77}$$

and the time of interval III is load current dependant:

$$t_{III} = \frac{I_o L_R}{V_s} \times (1 - \cos \omega_o t_{II}) \tag{21.78}$$

The freewheel diode current is given by

$$i_{D1}(t) = I_o + i_{D_o}(t) \tag{21.79}$$

**Time interval IV**

At  $t_6$ , the supply  $V_s$  provides all the load current through the switch resonant inductor, and the diode  $D_1$  recovers with a controlled  $di/dt$  given by  $V_s / L_R$ . The freewheel diode  $D_f$  supports the supply voltage  $V_s$ . The switch conduction interval  $IV$ ,  $t_6$  to the subsequent  $t_0$  when the switch is turned off, is used to control the rate at which energy is transferred to the load.

**Output voltage**

The output voltage, which is always less than the input voltage, can be derived from the diode voltage (shown hatched in figure 21.16b) since this voltage is averaged (filtered) by the output L-C filter.

$$\begin{aligned} V_o &= \frac{1}{\tau} (\text{Volt} \times \text{second area of interval I} + \text{Volt} \times \text{second area of interval IV}) \\ &= \frac{V_s}{\tau} (1/2 t_1 + \tau - t_6) = V_s (1 - f_s (t_6 - 1/2 t_1)) \\ &= 2\pi \frac{V_s}{\omega_o \tau} \left( 1 - \left( 1/2 + \frac{I_o Z_o}{2\pi V_s} \right) \right) \end{aligned} \tag{21.80}$$

The circuit has a number of features:

- i. Switch turn-on and turn-off both occur at zero voltage, hence switching losses are minimal.
- ii. At light load currents, the switching frequency may become extreme high.
- iii. The inductor defluxing (reset) time is  $t_{III} \leq I_{o,III} \times L_R / V_s$ , hence the output voltage is load current dependant.
- iv.  $L_R$  and  $C_R$  are dimensioned such that the inductor current is less than zero (being returned to the supply  $V_s$ ) at time  $t_5$ , at maximum load current  $I_o$ . Also  $I_o > V_s / Z_o$ .
- v. Being based on the forward converter, the output voltage is less than the input voltage. Increasing the switching frequency decreases the output voltage since  $\tau - t_6$  is decreased in equation (21.80).

**21.5.3i - Zero-voltage, full-wave resonant switch converter**

By removing the supply return diode in the half-wave ZVS converter in figure 21.12e (figure 21.16) a full-wave ZVS resonant converter is formed, where the capacitor sinusoidal oscillation can continue past  $\pi$ ,  $t_4$ , as shown in figure 21.17. Consequently, the inductor current attains a level closer to the load level,  $I_o$ , before the capacitor voltage oscillation is complete, thereby shortening the cycle time.

**21.5.4 Zero-voltage, resonant-switch, dc to dc converter - 1/2 wave,  $C_R$  parallel with load version**

Operation of the ZVS circuit in figure 21.12d, where the capacitor  $C_R$  is connected in parallel with the load circuit (the freewheel diode  $D_f$ ), is essentially the same as the circuit in figure 21.17. The capacitor connection produces the result that the capacitor voltage has a dc offset of  $V_s$ , meaning its voltage swings between  $+V_s$  and  $-I_o Z_o$ , rather than zero and  $V_s - I_o Z_o$ , as in the ZVS circuit considered in 21.5.3. Specifically the inductor waveforms and expressions are unchanged, as is the output voltage expression (21.80). The expression for the time of each interval is the same and the capacitor voltage waveform equations are negated, with  $V_s$  then added.

Any dc supply inductance must be decoupled when using the ZVS circuit in figure 21.12d.

It will be noticed that, at a given load current  $I_o$ , a ZCS converter has a predetermined on-time, while a ZVS converter has a predetermined off-time.

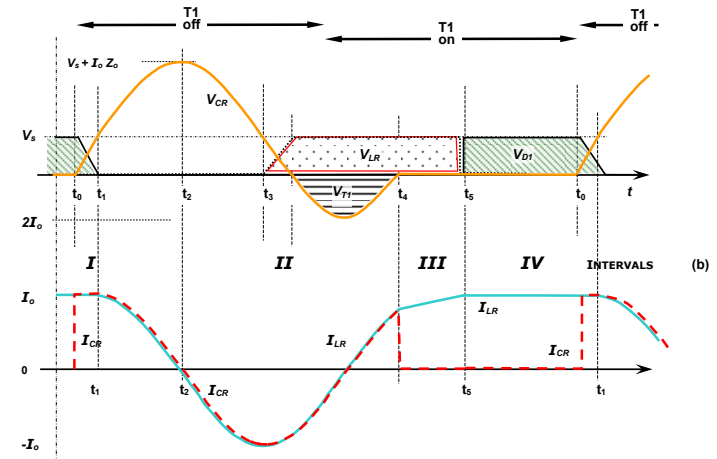
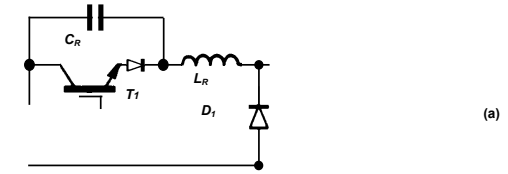

Figure 21.17. Zero voltage switching, ZVS, full-wave resonant switch dc to dc converter with the resonant capacitor across the switch: (a) circuit and (b) waveforms.

**Example 21.2: Zero-current, resonant-switch, step-down dc to dc converter - 1/2 wave**

The ZCS resonant dc step-down voltage converter in figure 21.13a produces an output voltage for the armature of a high voltage dc motor and operates from the voltage produced from the 50Hz ac mains rectified, 340V dc, with an L-C dc link filter. The resonant circuit parameters are  $L_R = 100\mu\text{H}$ ,  $C_R = 0.47\mu\text{F}$ , and the high frequency ac resistance of the resonant circuit is  $R_c = 1\Omega$ .

Calculate

- i. the circuit  $Z_o$ ,  $Q$ , and  $\omega_o$
- ii. the maximum output current to ensure ZCS occurs
- iii. the maximum operating frequency, represented by the time between switch turn on and the freewheel diode recommencing conduction, at maximum load current
- iv. the average diode voltage (capacitor voltage), hence load voltage at the maximum frequency
- v. switching frequency for  $v_o = 170\text{V}$  dc and  $R_L = 17\Omega$ , peak input current, and diode maximum reverse voltage.

**Solution**

- i. The characteristic impedance is given by

$$Z_o = \sqrt{\frac{L_R}{C_R}} = \sqrt{\frac{100\mu\text{H}}{0.47\mu\text{F}}} = 14.6\Omega$$

The resonant circuit Q is

$$Q = \frac{Z_o}{R_c} = \frac{100\mu\text{H}}{0.47\mu\text{F}} / 1\Omega = 14.6$$



For this high Q, the circuit resonant frequency and damped frequency will be almost the same, that is

$$\begin{aligned} \omega &\approx \omega_o = 1 / \sqrt{L_R C_R} \\ &= 1 / \sqrt{100\mu\text{H} \times 0.47\mu\text{F}} = 146 \text{ krad/s} = 2\pi f \\ f &= 146 \text{ krad/s} / 2\pi = 23.25 \text{ kHz} \quad \text{or} \quad T = 43\mu\text{s} \end{aligned}$$

ii. For zero current switching, the load current must not be greater than the peak resonant current, that is

$$I_o < V_s / Z_o = 340\text{V} / 14.6\Omega = 23.3\text{A}$$

iii. The commutation period comprises the four intervals, I to IV, shown in figure 21.13b.

Interval I

The switch turns on and the inductor current rises from 0A to 23.3A in a time given by

$$\begin{aligned} t_I &= L_R \Delta I / V_s \\ &= 100\mu\text{H} \times 23.3\text{A} / 340\text{V} = 6.85\mu\text{s} \end{aligned}$$

Interval II

These two sub-intervals take over half a resonant cycle to complete. Assuming action is purely sinusoidal resonance then from equation (21.36)

$$\begin{aligned} t_{II} &= \left( \pi + \sin^{-1} \left( \frac{I_o Z_o}{V_s} \right) \right) / \omega_o \\ &= \left( \pi + \sin^{-1} \left( \frac{23.3\text{A} \times 14.6\Omega}{340\text{V}} \right) \right) / 146 \text{ krad/s} = 32.27\mu\text{s} \end{aligned}$$

The capacitor voltage at the end of this period is given by

$$\begin{aligned} V_{C_R t_4} &= V_s (1 - \cos \omega_o t_{II}) \\ &= 340\text{V} \times (1 - \cos \frac{1}{2} \pi) = 340\text{V} \end{aligned}$$

Interval III

The capacitor voltage must discharge from 340V dc to zero volts, providing the 23.3A load current. That is

$$t_{IV} = V_{C_R t_4} \times C_R / I_o = 340\text{V} \times 0.47\mu\text{F} / 23.3\text{A} = 6.86\mu\text{s}$$

The minimum commutation cycle time is therefore 6.85+32.27+6.86 = 46μs. Thus the maximum operating frequency is 21.75kHz.

iv. The output voltage  $v_o$  is the average reverse voltage of freewheel diode D<sub>1</sub>, which is in parallel with the resonant capacitor C<sub>R</sub>. Integration of the capacitor voltage shown in figure 21.13b gives equation (21.42)

$$\begin{aligned} v_o &= \frac{1}{t_s} \left[ \int_0^{t_4-t_1} V_s (1 - \cos \omega t) dt + \int_0^{t_5-t_4} V_{C_R t_4} \left( 1 - \frac{t}{t_5-t_4} \right) dt \right] \\ &= \frac{1}{46\mu\text{s}} \times \left[ \int_0^{32.27\mu\text{s}} 340\text{V} \times (1 - \cos \omega t) dt + \int_0^{6.86\mu\text{s}} 340\text{V} \times \left( 1 - \frac{t}{6.86\mu\text{s}} \right) dt \right] \\ &= \frac{1}{46\mu\text{s}} \times \left[ 340\text{V} \times \left( \frac{3\pi}{2} + 1 \right) \times \frac{43\mu\text{s}}{2\pi} + \frac{1}{2} \times 340\text{V} \times 6.86\mu\text{s} \right] \\ &= \frac{1}{46\mu\text{s}} \times [13292\text{V}\mu\text{s} + 1166\text{V}\mu\text{s}] = 314.3\text{Vdc} \end{aligned}$$

The maximum output voltage is 314V dc. Alternatively, using the input inductor energy based equation (21.41):

$$\begin{aligned} v_o &= \frac{V_s}{\tau} (\frac{1}{2} t_I + t_{II-III} + t_{IV}) \\ &= \frac{340\text{V}}{46\mu\text{s}} \times (\frac{1}{2} \times 6.85\mu\text{s} + 32.25\mu\text{s} + 6.86\mu\text{s}) = 314.4\text{V} \end{aligned}$$

v. When the output current is  $v_o/R_L=170\text{V}/17\Omega=10\text{A}$ , the operating frequency is obtained from equation (21.41)

$$v_o = \frac{V_s}{\tau} \times \left[ \frac{1}{2} \frac{I_o L_R}{V_s} + \frac{\left( \pi + \sin^{-1} \left( \frac{I_o Z_o}{V_s} \right) \right)}{\omega_o} + V_s \left( 1 + \sqrt{1 - \left( \frac{I_o Z_o}{V_s} \right)^2} \right) \times \frac{C_R}{I_o} \right]$$

$$170\text{V} = \frac{340\text{V}}{\tau} \times \left[ \frac{1}{2} \times \frac{10\text{A} \times 100\mu\text{H}}{340\text{V}} + \frac{\left( \pi + \sin^{-1} \left( \frac{10\text{A} \times 14.6\Omega}{340\text{V}} \right) \right)}{146 \text{ krad/s}} + 340\text{V} \times \left( 1 + \sqrt{1 - \left( \frac{10\text{A} \times 14.6\Omega}{340\text{V}} \right)^2} \right) \times \frac{0.47\mu\text{F}}{10\text{A}} \right]$$

That is,  $\tau = 108.2\mu\text{s}$ , or  $f_s = 9.25\text{kHz}$ .

The peak input current is the peak inductor current is

$$I_{iP} = I_{iL} = I_o + \frac{V_s}{Z_o} = 10\text{A} + \frac{340\text{V}}{14.6\Omega} = 33.3\text{A}$$

The diode peak reverse voltage is  $2 \times V_s = 640\text{V}$

♣

**Example 21.3: Zero-current, resonant-switch, step-down dc to dc converter – full-wave**

In example 21.2, a diode is connected in anti-parallel with the switch (figure 21.14), forming a quasi resonant full-wave switch, dc converter. Using the data in example 21.2:

- i. Determine the maximum operating frequency with a 10A load current.
- ii. Repeat the calculations when an infinite Q is not assumed.

**Solution**

Using the data in example 21.2:

$$\begin{aligned} \omega_o &= 1 / \sqrt{L_R C_R} = 1 / \sqrt{100\mu\text{H} \times 0.47\mu\text{F}} = 146 \text{ krad/s} \\ Z_o &= \sqrt{\frac{L_R}{C_R}} = \sqrt{\frac{100\mu\text{H}}{0.47\mu\text{F}}} = 14.6\Omega \quad Q = \frac{Z_o}{R_c} = \frac{100\mu\text{H}}{0.47\mu\text{F}} / 1\Omega = 14.6 \\ \alpha &= \frac{R}{2L} = \frac{1\Omega}{2 \times 100\mu\text{H}} = 5,000 \\ \omega &= \sqrt{\omega_o^2 - \alpha^2} = \sqrt{(146 \text{ krad/s})^2 - 0.005^2} = 146.1 \text{ krad/s} \end{aligned}$$

i. Three intervals are involved.

Interval I is given by equation (21.29)

$$\begin{aligned} t_I &= L_R \Delta I / V_s \\ &= 100\mu\text{H} \times 10\text{A} / 340\text{V} = 2.94\mu\text{s} \end{aligned}$$

The time for interval II is given by equation (21.50)

$$\begin{aligned} t_{II} &= \left( 2\pi - \sin^{-1} \left( \frac{I_o Z_o}{V_s} \right) \right) / \omega_o \\ &= \left( 2\pi - \sin^{-1} \left( \frac{10\text{A} \times 14.6\Omega}{340\text{V}} \right) \right) / 146 \text{ krad/s} = 40.0\mu\text{s} \end{aligned}$$

The capacitor voltage at the end of interval II is

$$\begin{aligned} V_{C_R t_4} &= V_s (1 - \cos \omega_o t_{II}) \\ &= 340\text{V} \times (1 - \cos (146 \text{ krad/s} \times 40.0\mu\text{s})) = 32.8\text{V} \end{aligned}$$

Interval III

The capacitor voltage must discharge from 32.8V dc to zero volts, providing 10A load current. That is

$$\begin{aligned} t_{IV} &= V_{C_R t_4} \times C_R / I_o \\ &= 32.8\text{V} \times 0.47\mu\text{F} / 10\text{A} = 1.5\mu\text{s} \end{aligned}$$

The minimum commutation cycle time is therefore 2.94 + 40 + 1.5 = 44.44μs. Thus the maximum operating frequency is 22.5kHz.

ii. Circuit Q does not affect the first interval, which from part i. requires 2.94μs.

When a finite Q of 14.6 is used, equations (21.31) and (21.32) are employed for the second interval, the resonant part of the cycle. From equation (21.32)

$$\begin{aligned} i_c(\omega t) &= \frac{V_s}{\omega L} \times e^{-\alpha t} \times \sin \omega t \\ -10\text{A} &= \frac{340\text{V}}{146 \text{ krad/s} \times 100\mu\text{H}} \times e^{-\frac{10}{2 \times 100\mu\text{H}} t} \times \sin(146 \text{ krad/s} \times t) \end{aligned}$$

which yields  $t = 39.27\mu\text{s}$ . The capacitor voltage at this time is given by equation (21.31), that is

$$v_c(\omega \times t) = V_s(1 - e^{-\omega t} \cos \omega t)$$

$$v_c(146\text{krad/s} \times 39.27\mu\text{s}) = 340\text{V} \times (1 - e^{-5.000 \times 39.27\mu\text{s}} \times \cos(146\text{krad/s} \times 39.27\mu\text{s}))$$

$$= 101.8\text{V}$$

The time for interval III is given by equation (21.40), that is

$$t_{III} = \frac{V_{CR} t_{II} C_R}{I_o} = \frac{101.8\text{V} \times 0.47\mu\text{F}}{10\text{A}} = 4.78\mu\text{s}$$

The minimum commutation cycle time is therefore  $2.94 + 39.27 + 4.78 = 47.0\mu\text{s}$ . Thus the maximum operating frequency is  $21.3\text{kHz}$ , which is required for maximum voltage output at  $10\text{A}$ .

The main effect of a finite  $Q$  is to result in a higher voltage being retained on the capacitor to be discharged into the load at a constant rate, during interval III. Never-the-less this voltage is much less than that retained in the half-wave resonant switch case.

#### Example 21.4: Zero-voltage, resonant-switch, step-down dc to dc converter - $\frac{1}{2}$ wave

The zero voltage resonant switch converter in figure 21.16 operates under the following conditions:

$$V_s = 192\text{V} \quad I_o = 25\text{A}$$

$$L_R = 10\mu\text{H} \quad C_R = 0.1\mu\text{F}$$

Determine

- the minimum output current
- the switching frequency  $f_s$  for  $v_o = 48\text{V}$
- switch average current and
- the peak switch/diode/capacitor voltage.

**Solution**

$$\omega_o = \frac{1}{\sqrt{L_R C_R}} = \frac{1}{\sqrt{10\mu\text{H} \times 0.1\mu\text{F}}} = 1 \times 10^6 \text{ rad/s} \quad \text{that is } f_o = 159.2\text{kHz}$$

$$Z_o = \sqrt{\frac{L_R}{C_R}} = \sqrt{\frac{10\mu\text{H}}{0.1\mu\text{F}}} = 10\Omega$$

- i. For proper resonant action the maximum average output current must satisfy,  $I_o > V_s / Z_o$ , that is

$$I_o > \frac{V_s}{Z_o} = \frac{192\text{V}}{10\Omega} = 19.2\text{A}$$

Since the load current,  $25\text{A}$  is larger than the minimum current requirement,  $19.2\text{A}$ , the switch voltage will be reduced zero giving ZVS turn-off.

- ii. The period of interval I is given by equation (21.67), that is

$$t_I = \frac{V_s C_R}{I_o} = \frac{192\text{V} \times 0.1\mu\text{F}}{25\text{A}} = 0.768\mu\text{s}$$

The period of interval II is given by equation (21.73), that is

$$t_{II} = t_3 - t_1 = \left( \pi + \sin^{-1} \frac{V_s}{I_o Z_o} \right) / \omega_o = \left( \pi + \sin^{-1} \frac{192\text{V}}{25\text{A} \times 10\Omega} \right) / 10^6 \text{ rad/s} = 4.017\mu\text{s}$$

The period for the constant current period III is given by equation (21.78)

$$t_{III} = \frac{I_o L_R}{V_s} \times (1 - \cos \omega_o t_{II}) = \frac{25\text{A} \times 10\mu\text{H}}{192\text{V}} \times (1 - \cos(10^6 \times 4.017\mu\text{s})) = 2.136\mu\text{s}$$

After re-arranging equation (21.80), the switching frequency is given by

$$f_s = \frac{\left(1 - \frac{V_o}{V_s}\right)}{t_5 - \frac{1}{2}t_1} = \frac{\left(1 - \frac{48\text{V}}{192\text{V}}\right)}{(0.768\mu\text{s} + 4.017\mu\text{s} + 2.136\mu\text{s} - \frac{1}{2} \times 0.768\mu\text{s})} = 114.7\text{kHz}$$

- iii. The switch current is shown by hatched dots in figure 21.16. The average value is dominated by interval IV, with a small contribution in interval II between  $t_5$  and  $t_6$ .

$$\bar{I}_T = \frac{I_o}{\tau} \times \left( \frac{V_2 \times t_{III}}{1 + |\cos \omega_o t_{II}|} + (\tau - t_6) \right)$$

$$= 25\text{A} \times 114.7\text{kHz} \left( \frac{V_2 \times 2.136\mu\text{s}}{1 + |\cos(10^6 \times 4.017\mu\text{s})|} + \left( \frac{1}{114.7\text{kHz}} - (0.768\mu\text{s} + 4.017\mu\text{s} + 2.136\mu\text{s}) \right) \right)$$

$$= 7.0\text{A}$$

- iv. The peak switch/diode/capacitor voltage is given by equation (21.71), namely

$$V_c = V_s + I_o Z_o$$

$$= 192\text{V} + 25\text{A} \times 10\Omega = 442\text{V}$$

## 21.6 Resonant-switch, dc to dc step-up voltage converters

### 21.6.1 ZCS resonant-switch, dc to dc step-up voltage converters

The zero current resonant ZCS (and ZVS) principle can be applied to the step-up converter (and buck-boost converter), as shown in figure 21.18b. The resonant L-C circuit around the switch does not affect the primary boosting function, but only facilitates resonant switching of switch  $T$ . But now the output voltage is determined by the switch off-time.

When the switch  $T$  is off, the input inductor  $L$  provides near constant current to the output circuit through diode  $D$ . The inductor current  $I_L$  comprises the load current  $I_o$  and the output capacitor current  $I_C$ . The resonant capacitor  $C_R$  is charged to the output voltage  $v_o$ , as is the output capacitor  $C$ .

**Period I:**  $t_{P1}$

When the switch is turned on at  $t_o$ , the input current  $I_i$  is progressively diverted to the resonant inductor  $L_R$  as its current builds up linearly according to

$$i_{LR}(t) = \frac{V_o}{L_R} t \quad (21.81)$$

The current to the output circuit,  $I_D$ , through diode  $D$ , decreases linearly according to

$$i_D(t) = I_i - i_{LR}(t) = I_i - \frac{V_o}{L_R} t \quad (21.82)$$

At time  $t_1$  the resonant inductor consumes all the input current, when

$$t_{P1} = \frac{L_R I_i}{V_o} \quad (21.83)$$

**Period II:**  $t_{P2}$

The resonant capacitor can now resonate through  $L_R$  and the switch  $T$ . The inductor resonant current is superimposed on the constant input current, the constant current not producing any voltage across the inductor since  $di/dt$  is zero for a constant current.

The inductor, hence switch, current is

$$i_{LR}(t) = I_i + \frac{V_o}{Z} \sin \omega t \quad (21.84)$$

$$\text{where } Z = \sqrt{\frac{L_R}{C_R}} \quad \text{and } \omega = \frac{1}{\sqrt{L_R C_R}}$$

while the resonant capacitor current is

$$i_{CR}(t) = -\frac{V_o}{Z} \sin \omega t \quad (21.85)$$

The resonant capacitor and inductor are in parallel hence

$$v_{LR}(t) = v_{CR}(t) = L_R \frac{di_{LR}}{dt} = v_o \sin \omega t \quad (21.86)$$

The maximum switch capacitor and inductor currents occur at  $t_2$ , namely  $\omega t = \frac{1}{2}\pi$ , when

$$\hat{i}_{CR} = -\frac{V_o}{Z} \quad (21.87)$$

$$\hat{i}_T = \hat{i}_{LR} = I_i + \frac{V_o}{Z}$$

The resonant capacitor current is zero when the inductor current falls back to the input current level  $I_i$ , that is, at time  $t_3$  when  $\omega t = \pi$ .

The oscillation continues according to equation (21.84) and the resonant inductor current falls to zero at  $t_4$ , namely time

$$t_{LR-0} = \frac{1}{\omega} \sqrt{\pi + \sin^{-1} \frac{ZI_i}{V_o}} \quad (21.88)$$

when the resonant circuit voltage from equation (21.86) is

$$V_{LR}(t_{LR-0}) = V_{CR}(t_{LR-0}) = -V_o \sqrt{1 - \left(\frac{ZI_i}{V_o}\right)^2} \quad (21.89)$$

and the resonant capacitor current is

$$i_{CR}(t_{LR-0}) = I_i \quad (21.90)$$

The input current now charges the resonant capacitor with a constant current  $I_o$ .

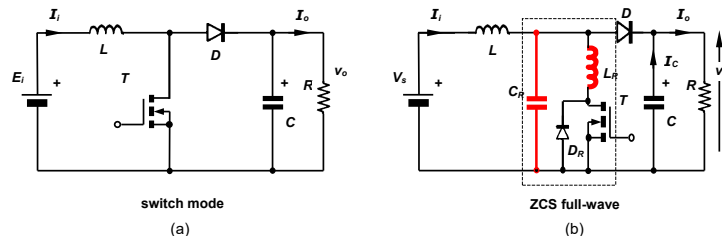

Figure 21.18. Zero current switching, ZCS, full-wave resonant switch dc to dc step-up voltage converter: (a) conventional smps circuit; (b) ZCS resonant circuit; and (c) waveforms.

During period 2, all the load current  $I_o$  is provided by the output capacitor C, and the output diode D is reverse biased.

Due to the resonant capacitor retaining a negative voltage at time  $t_4$ , the resonant oscillation current reverses for a negative half resonant cycle through the switch antiparallel diode  $D_R$ . During this period when the antiparallel diode  $D_R$  conducts, the switch can be turned off under a zero current condition.

The inductor current returns to zero at time  $t_5$

$$t_{p2} = \frac{1}{\omega} \left[ 2\pi - \sin^{-1} \frac{ZI_i}{V_o} \right] \quad (21.91)$$

The capacitor voltage is given by equation (21.86) at the time  $t_{p2}$ , namely

$$V_{LR}(t_{p3}) = V_{CR}(t_{p3}) = V_o \sin \omega t_{p3} = V_o \sqrt{1 - \left(\frac{ZI_i}{V_o}\right)^2} \quad (21.92)$$

**Period III:  $t_{p3}$**

The constant input current  $I_i$  charges the resonant capacitor  $C_R$  linearly to the output voltage level  $v_o$ . At this voltage the output capacitor C ceases to provide load current  $I_o$  since diode D conducts and the input current provides the load current  $I_o$  and replenishes to output capacitor C with the remainder of the input current,  $I_i - I_o$ . The charging time of the resonant capacitor  $C_R$  is load current magnitude  $I_o$  dependent.

$$V_{CR}(t) = V_{CR}(t_{p3}) + \frac{I_i}{C_R} t \quad (21.93)$$

**21.6.2 ZVS resonant-switch, dc to dc step-up voltage converters**

**i. ZVS boost #1**

The alternative boost resonant ZVS converter in figure 21.19a uses a constant current input as in figure 18.10 in chapter 18.7, but the output is half-wave rectified by the diode  $D_{rect}$ .

Initially, before  $t_0$ , the switch is on and the load requirement  $I_o$  is being provided by the output capacitor C. The large input inductance ensures a constant input current  $I_i$ , which is conducted by the switch T. The resonant circuit capacitor voltage is zero, as is the initial resonant inductor current.

The switch T is turned off at  $t_0$  and the resonant circuit waveforms as in figure 21.19 parts b and c occur.

**Period I:  $t_{p1}$**

The resonant capacitor charges with the constant input current which is diverted by the turn-off of switch T. The capacitor and parallel connected switch voltages increases according to

$$V_T(t) = V_{CR}(t) = \frac{I_i}{C_R} t \quad (21.94)$$

The capacitor and switch voltage rise linearly until equal to the output voltage  $v_o$ , when the output rectifying diode becomes forward biased at time  $t_1$ . The time for this first period is

$$t_{p1} = \frac{V_o}{I_i} C_R \quad (21.95)$$

**Period II:  $t_{p2}$**

The output rectifying diode  $D_{rect}$  is able to conduct and allows L-C resonance between  $L_R$  and  $C_R$  where the inductor is clamped to the output voltage  $v_o$  and both  $L_R$  and  $C_R$  are fed from the constant current source  $I_i$ . These two dc conditions do not prevent an ac resonant oscillation from occurring. The voltage across the capacitor increases from  $v_o$  at time  $t_1$  according to

$$V_{CR}(t) = V_o + I_i Z \sin \omega t \quad (21.96)$$

where  $Z = \sqrt{\frac{L_R}{C_R}}$  and  $\omega = \frac{1}{\sqrt{L_R C_R}}$

The inductor voltage hence current are

$$\begin{aligned} V_{LR}(t) &= V_o - V_{CR}(t) = -I_i Z \sin \omega t \\ i_{LR}(t) &= I_i (1 - \cos \omega t) \end{aligned} \quad (21.97)$$

This inductor current replenishes to output capacitor C whilst providing a portion of the load current  $I_o$ . The capacitor current resonantly decreases from  $I_i$  according to

$$i_{CR}(t) = I_i - i_{LR} = I_i \cos \omega t \quad (21.98)$$

This period continues until the capacitor voltage given by equation (21.96) reaches zero at time  $t_4$ . This zero voltage condition is necessary if the switch is to turn-on with zero voltage and from equation (21.96) a zero voltage condition occurs provided  $I_i Z > v_o$ . The capacitor voltage reaches zero and attempts to reverse at time  $t_4$ . The duration of the resonant period is

$$t_{p2} = \frac{\pi + \sin^{-1}\left(\frac{V_o}{I_i Z}\right)}{\omega} \tag{21.99}$$

The inductor current (whence capacitor current) at the instant  $t_4$  is

$$i_{LR}(t_4) = I_i \left(1 + \sqrt{1 - \left(\frac{V_o}{I_i Z}\right)^2}\right) \tag{21.100}$$

$$i_{CR}(t_4) = i_{LR}(t_4) - I_i = I_i \sqrt{1 - \left(\frac{V_o}{I_i Z}\right)^2}$$

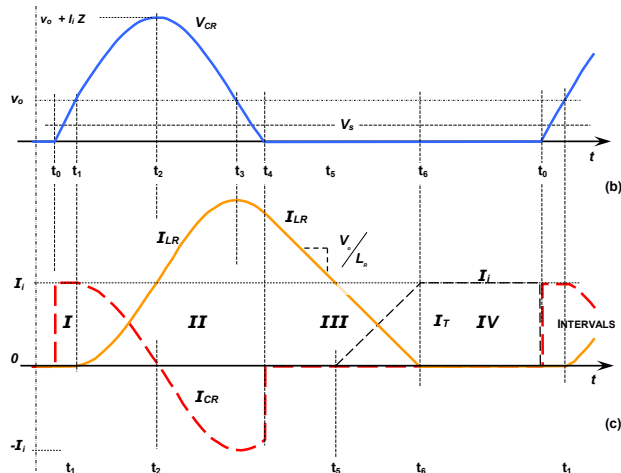
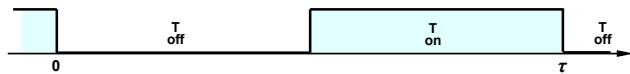
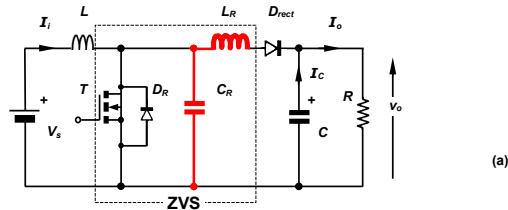

Figure 21.19. Zero voltage switching, ZVS, full-wave resonant switch dc to dc step-up voltage converter: (a) ZVS resonant circuit; (b) resonant capacitor voltage; and (c) current waveforms.

**Period III:  $t_{p3}$**

At time  $t_4$  the diode  $D_R$  conducts, preventing the resonant capacitor from charging negatively. The resonant inductor releases its energy into the load circuit at a constant voltage  $v_o$ , according to

$$i_{LR}(t) = I_i \left(1 + \sqrt{1 - \left(\frac{V_o}{I_i Z}\right)^2}\right) - \frac{V_o}{L_R} t \tag{21.101}$$

The diode  $D_R$  current decreases linearly to zero at time  $t_5$  according to

$$i_{DR}(t) = I_i - i_{LR}(t) = -I_i \sqrt{1 - \left(\frac{V_o}{I_i Z}\right)^2} + \frac{V_o}{L_R} t \tag{21.102}$$

And reaches zero at time  $t_5$  after a period

$$t_{p3a} = \frac{1}{\omega} \frac{I_i Z}{V_o} \sqrt{1 - \left(\frac{V_o}{I_i Z}\right)^2} = L_R \frac{I_i}{V_o} \sqrt{1 - \left(\frac{V_o}{I_i Z}\right)^2} \tag{21.103}$$

At time  $t_5$ , the resonant inductor current is the input current  $I_i$  and the switch is turned on between  $t_4$  and  $t_5$  in order to achieved zero voltage turn-on ZVS. The inductor current continues to fall at the same rate to zero as the switch current linearly increases to  $I_i$

$$i_T(t) = I_i - I_{LR}(t) = \frac{V_o}{L_R} t \tag{21.104}$$

The inductor current reaches zero at time  $t_6$  that is input current  $I_i$  (hence load current  $I_o$ ) dependent. The time for the inductor current to fall from the input current level  $I_i$  at time  $t_5$  to zero at time  $t_6$  is:

$$t_{p3b} = L_R \frac{I_i}{V_o} \tag{21.105}$$

The time for the third period ( $t_3$  to  $t_6$ ) is

$$t_{p3} = T_{p3a} + t_{p3b} = L_R \frac{I_i}{V_o} \left(1 + \sqrt{1 - \left(\frac{V_o}{I_i Z}\right)^2}\right) \tag{21.106}$$

At time  $t_6$  the switch conducts the input current  $I_i$ , and can be turned off so as to control the output voltage  $v_o$ .

**ii. ZVS boost #2**

The ZVS boost converter in 21.6.2i, #1, operates in a half wave mode since the mosfet has an intrinsic internal parasitic diode which prevents negative voltages. The ZVS boost circuit variations in figure 21.20 facilities full-wave as well as half wave operation. Operation can be divided into four sequential periods, as indicated on the circuit waveforms in figure 21.21.

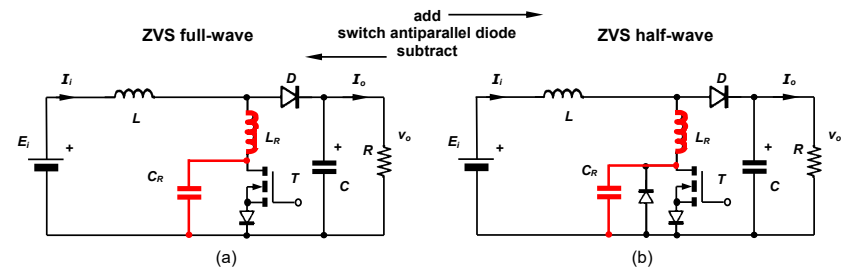

Figure 21.20. Zero voltage switching, ZVS, resonant switch dc to dc step-up voltage converters: (a) ZVS full wave circuit and (b) half wave circuit.

**Period I:** Between time zero and  $t_1$  both the switch T and diode D conduct. The inductor current in  $L_R$  rise until it reaches the input current  $I_i$ , at which instant the diode feeding diode current fall to zero.

**Period II:** With diode D blocking the switch conducts all the input current  $I_i$ , clamping the capacitor  $C_R$  voltage to zero.

**Period III:** When the switch T is turned off, energy in  $L_R$  is diverted to  $C_R$ , increasing its voltage having initially clamped the switch T turn off voltage to zero, ZVS. When the capacitor voltage rises to the output voltage level, the diode D conducts.

**Period IV:** With D conducting, the input current is progressively transferred to the output. Energy in  $L_R$  resonantly transfers to  $C_R$  until the voltage on  $C_R$  resonates back to zero. If used, the half-wave diode clamps the capacitor voltage to zero.

The output voltage transfer function is determined by the switch T on time, periods II and III, that is for a boost converter  $T / T - (t_3 - t_1)$ .

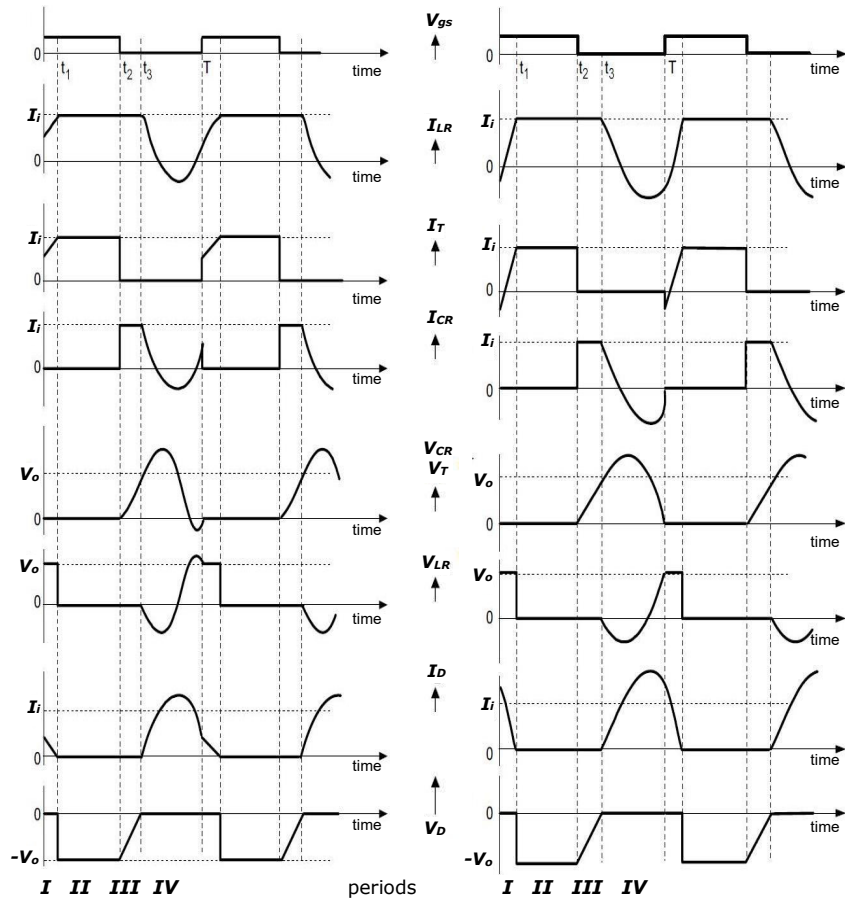

Figure 21.21. ZVS resonant switch dc to dc step-up voltage converter waveforms: (a) ZVS full wave circuit and (b) ZVS half wave circuit.

**Summary and comparison of ZCS and ZVS Converters**

The main characteristics of ZCS and ZVS are:

- Switch turn-on and turn-off occur at zero current or zero voltage, thus reducing switching losses.
- Rapid switch current and voltage changes are avoided in ZCS and ZVS, respectively. The  $di/dt$  and  $dv/dt$  values are small, hence EMI is reduced.
- In the ZCS, the peak current  $I_o + V_{dc}/Z_o$  conducted by the switch is more than twice as high as the maximum of the load current  $I_o$ .
- In the ZVS, the switch must withstand a forward voltage  $V_{dc} + Z_o I_o$ , while  $Z_o I_o$  must exceed  $V_{dc}$ .
- The switching frequency varies the output voltage.
- Switch parasitic capacitances are discharged during turn-on in ZCS, which can produce significant switching loss at high switching frequencies. This does not occur with ZVS.

**Table 21.3: Characteristics of resonant tank circuits**

| characteristic                       | series                                 | parallel                                      | series/parallel                         |
|--------------------------------------|--|---|---|
| Resonant frequency $\omega_o$        | constant                               | Load dependent                                | Load dependent                          |
| Open circuit output                  | OK                                     | Large current near resonance $\omega_o$       | Large current near resonance $\omega_o$ |
| Short circuit output                 | High current near resonance $\omega_o$ | Protected by $L$ at all $\omega$              | High current near resonance $\omega_o$  |
| Output voltage frequency sensitivity | High at no load and light loads        | Good light load regulation but low efficiency | OK but extra resonant component         |
| Equivalent load, $R_{eq}$            | $\frac{8}{\pi^2} R_{load}$             | $\frac{\pi^2}{8} R_{load}$                    | $\frac{\pi^2}{8} R_{load}$              |

**21.7 Appendix: Matrices of resonant switch buck, boost, and buck/boost converters**

A series switch diode may not be necessary when an inverse parallel diode is used, as with full-wave ZCS and half-wave ZVS circuits. In the following circuits, the series diode (preferably in the drain circuit) is used to block the MOSFET internal parasitic diode, which may have poor recovery characteristics.

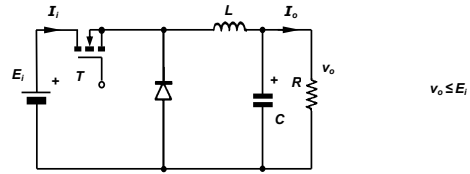

ZCS half-wave

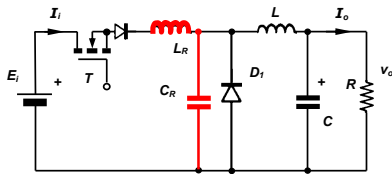

ZCS full-wave

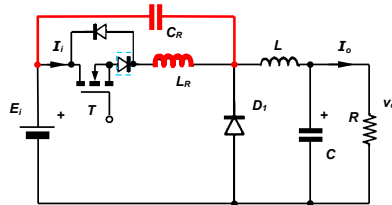
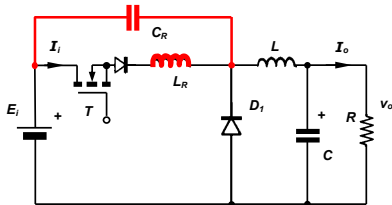
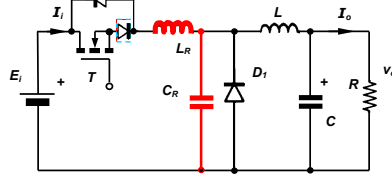

ZVS full-wave

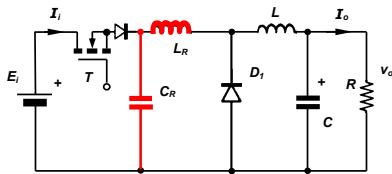

ZVS half-wave

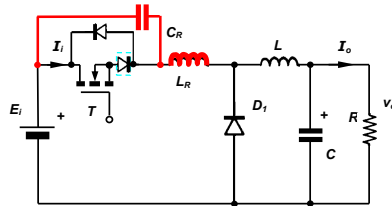
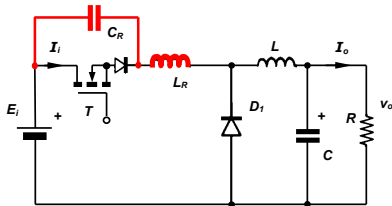
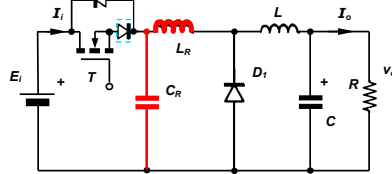
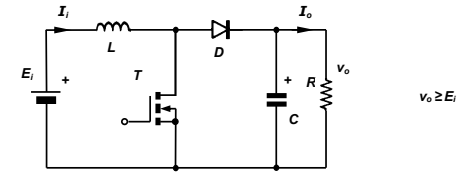
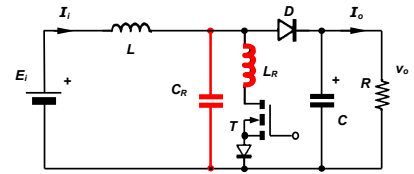

Figure 21.22. Forward (buck) voltage converter resonant switch circuits.



ZCS half-wave



ZCS full-wave

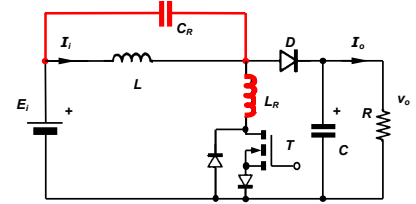
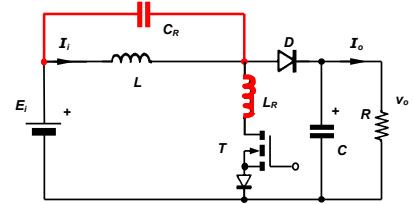
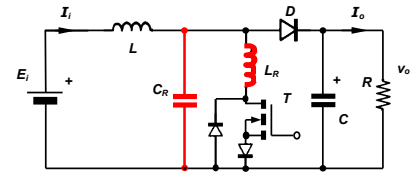

ZVS full-wave

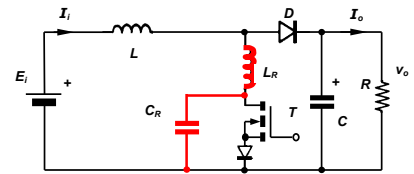

ZVS half-wave

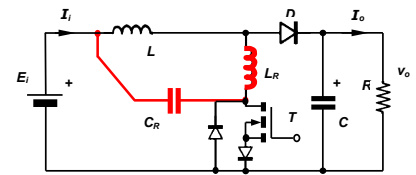
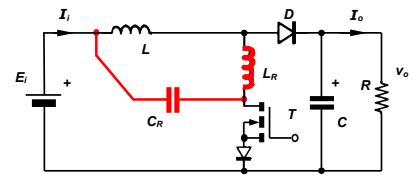
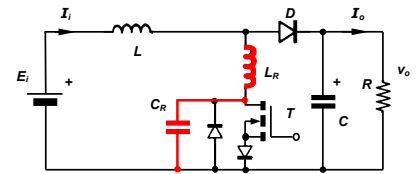
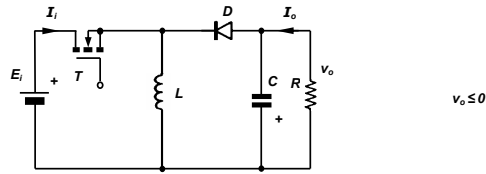
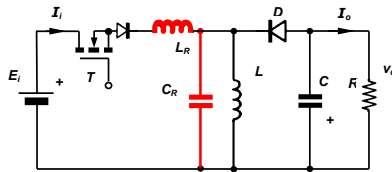

Figure 21.23. Setup (boost) voltage converter resonant switch circuits.



ZCS half-wave



ZCS full-wave

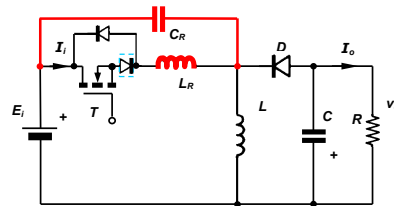
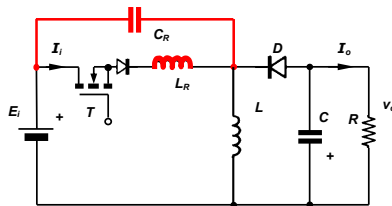
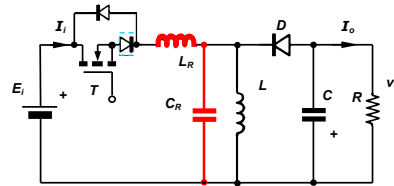

add →  
switch antiparallel diode  
← subtract

ZVS full-wave

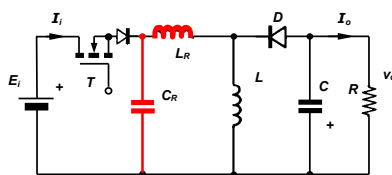

ZVS half-wave

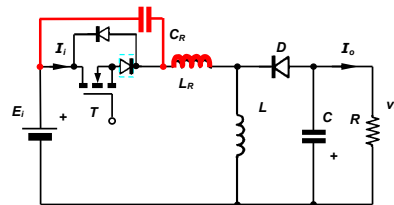
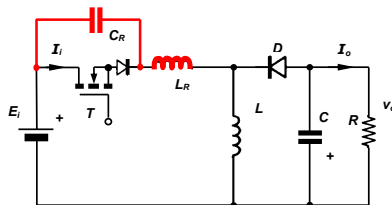
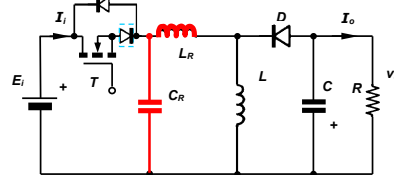

Figure 21.24. Setup/down (buck/boost) voltage converter resonant switch circuits.

Reading list

Hart, D.W., *Introduction to Power Electronics*,  
Prentice-Hall, Inc, 1997.

Mohan, N., et al., *Power Electronics*,  
3<sup>rd</sup> Edition, Wiley International, 2003.

Thorborg, K., *Power Electronics – in theory and practice*,  
Chartwell-Bratt, 1993.

Problems

Series resonant dc to dc converter

- 21.1. The series resonant dc converter in figure 21.1a operates from a 340V dc supply at 100kHz with a 17Ω load. If the series L-C resonant components are 100μH and 47nF, determine the output voltage assuming high resonant circuit Q.
- 21.2 If the operating frequency in problem 21.1 is decreased to 50kHz, determine suitable L-C values if the output voltage to be halved.

Parallel resonant dc to dc converter

- 21.3. The series resonant dc converter in figure 21.5a operates from a 340V dc supply at 100kHz with a 17Ω load. If the parallel L-C resonant components are 10μH and 470nF, determine the output voltage assuming high resonant circuit Q.
- 21.4 If the operating frequency in problem 21.3 is decreased to 50kHz, determine suitable L-C values if the output voltage to be halved.

Zero-current resonant switch converter

- 21.5 The zero current resonant switch converter in figure 21.13a operates with a 20V dc input supply and resonant L-C values of 5μH and 10nF, and a 5A output load requirement. Determine
  - i. the output voltage if the switching frequency is 100kHz
  - ii. the switching frequency if the output voltage is 10V
 In each case determine the maximum capacitor voltage and maximum inductor current.

Zero-voltage resonant switch converter

- 21.6 The zero current resonant switch converter in figure 21.16a operates with a 20V dc input supply and resonant L-C values of 10μH and 100nF, and a 5A output load requirement. Determine
  - i. the output voltage if the switching frequency is 100kHz
  - ii. the switching frequency if the output voltage is 10V
 In each case, determine the maximum capacitor voltage and maximum inductor current.