

CHAPTER 19

DC to DC Converters

- Switched-Mode

A switched-mode power supply (smps) or switching regulator, efficiently converts a dc voltage level to another dc voltage level, via an intermediate magnetic (inductor) storage/transfer stage, such that a continuous, possibly constant, load current flows, usually at power levels below a few kilowatts.

Shunt and series linear regulator power supplies dissipate much of their energy across the regulating transistor, which operates in the linear mode. An smps achieves regulation by varying the on to off time duty cycle of the switching element. This switching minimises losses, irrespective of load conditions.

Figure 19.1 illustrates the basic principle of the ac-fed smps in which the ac mains input is rectified, capacitively smoothed, and supplied to a high-frequency transistor chopper. The chopped dc voltage is transformed, rectified, and smoothed to give the required dc output voltage. A high-frequency transformer is used if an isolated output is required. The output voltage is sensed by a control circuit that adjusts the duty cycle of the switching transistor in order to maintain a constant output voltage with respect to load and input voltage variation. Alternatively, the chopper can be configured and controlled such that, in delivering the required output power $I-V$, the input current tracks a scaled version of the input ac supply voltage, therein producing unity (or controllable) power factor $I-V$ input conditions.

The switching frequency can be made much higher than the 50/60Hz line frequency; then the filtering and transformer elements used can be made small, lightweight, low in cost, and efficient.

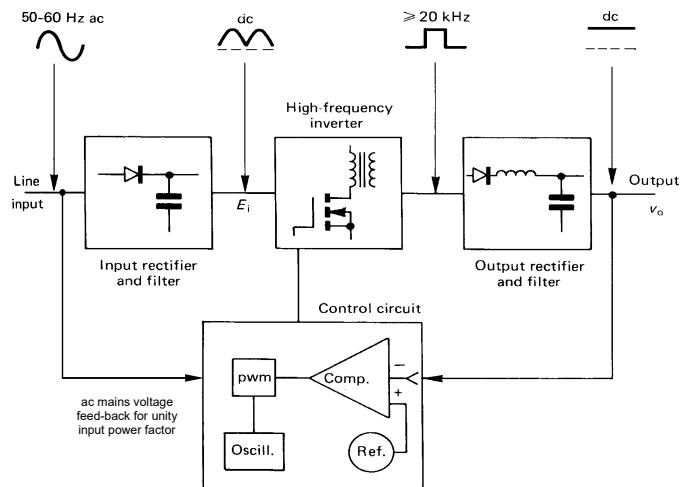

Figure 19.1. Functional block diagram of a switched-mode power supply.

Depending on the requirements of the application, the dc-to-dc converter can be one of four basic converter types, namely

- forward
- flyback
- balanced
- resonant.

19.1 The forward converter

The basic *forward converter*, sometimes called a step-down or *buck converter*, is shown in figure 19.2a. The input voltage E_i is chopped by transistor T. The symbol E is used at the input rather than V , because the input is an emf energy source. When T is on, because the input voltage E_i is greater than the load voltage v_o , energy is transferred from the dc supply E_i to L , C , and the load R . When T is turned off, stored energy in L is transferred via diode D to C and the load R .

If all the stored energy in L is transferred to C and the load before T is turned back on, operation is termed *discontinuous* inductor current, since the inductor current has reached zero. If T is turned on before the current in L reaches zero, that is, if continuous current flows in L , inductor operation is termed *continuous*.

Parts b and c respectively of figure 19.2 illustrate forward converter circuit current and voltage waveforms for continuous (figure 19.1b) and discontinuous (figure 19.1c) current conduction of inductor L .

For analysis it is assumed that components are lossless and the output voltage v_o is maintained constant because of the large magnitude of the capacitor C across the output. The input voltage E_i is also assumed constant, such that $E_i \geq v_o$.

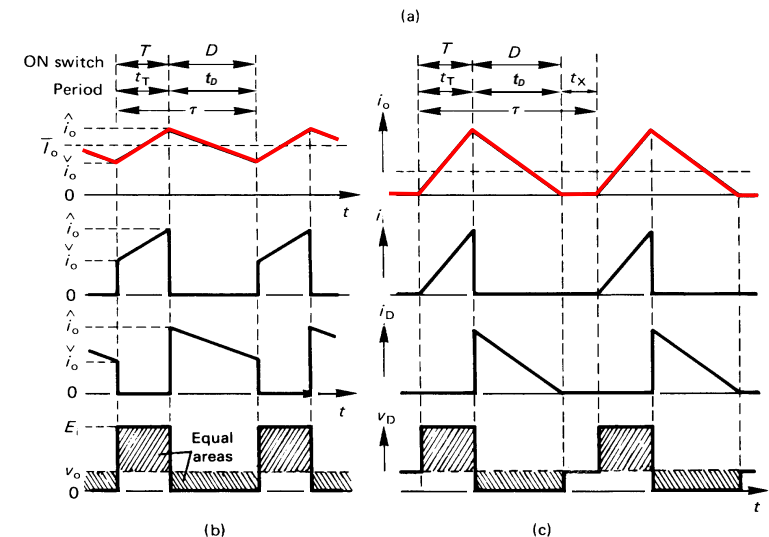
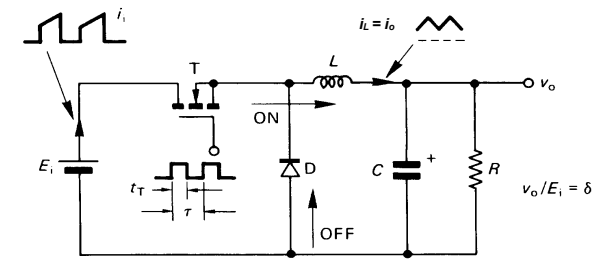

Figure 19.2. Non-isolated forward converter (*buck converter*) where $v_o \leq E_i$; (a) circuit diagram; (b) waveforms for continuous output (inductor) current; and (c) waveforms for discontinuous output (inductor) current.

19.1.1 Continuous inductor current (CCM - continuous conduction mode)

The inductor current is analysed first when the switch is on, then when the switch is off. When transistor T is turned on for period t_T , the difference between the supply voltage E_i and the output voltage v_o is impressed across L . From $V = L di/dt = L \Delta i/\Delta t$, the linear current change through the inductor will be

$$\Delta i_L = \hat{i}_L - \check{i}_L = \frac{E_i - v_o}{L} \times t_T \quad (19.1)$$

When T is switched off for the remainder of the switching period, $t_D = \tau - t_T$, the freewheel diode D conducts and $-v_o$ is impressed across L . Thus, using $V = L \Delta i/\Delta t$, rearranged, assuming continuous conduction (CCM)

$$\Delta i_L = \frac{v_o}{L} \times (\tau - t_T) \quad (19.2)$$

Equating equations (19.1) and (19.2), because the net inductor energy is constant, gives

$$(E_i - v_o) t_T = v_o (\tau - t_T) \quad (19.3)$$

This expression shows that the inductor average voltage is zero, and after rearranging with $v_o \bar{I}_o = E_i \bar{I}_i$:

$$\frac{v_o}{E_i} = \frac{\bar{I}_i}{\bar{I}_o} = \frac{t_T}{\tau} = \delta = t_T f \quad 0 \leq \delta \leq 1 \quad (19.4)$$

This equation also shows that for a given input voltage, the output voltage is determined by the transistor conduction duty cycle δ and the output is always less than the input voltage. This confirms and validates the original analysis assumption that $E_i \geq v_o$. The voltage transfer function is independent of the load R , circuit inductance L and capacitance C .

The inductor rms ripple current (and here capacitor ripple current) from equations (19.1) and (19.2), for continuous inductor current, is given by

$$i_{Lr} = \frac{\Delta i_L}{2\sqrt{3}} = \frac{1}{2\sqrt{3}} \frac{v_o}{L} (1 - \delta) \tau = \frac{1}{2\sqrt{3}} \frac{E_i}{L} (1 - \delta) \delta \tau \quad (19.5)$$

while the inductor total rms current is

$$i_{Lrms} = \sqrt{\bar{I}_L^2 + i_{Lr}^2} = \sqrt{\bar{I}_L^2 + \left(\frac{1/2 \Delta i_L}{\sqrt{3}}\right)^2} = \sqrt{\frac{1}{3} \left(\hat{i}_L^2 + \hat{i}_L \check{i}_L + \check{i}_L^2\right)} \quad (19.6)$$

The switch and diode average and rms currents are given by

$$\begin{aligned} \bar{I}_T &= \bar{I}_i = \delta \bar{I}_o & I_{Trms} &= \sqrt{\delta} i_{Lrms} \\ \bar{I}_D &= \bar{I}_o - \bar{I}_i = (1 - \delta) \bar{I}_o & I_{Drms} &= \sqrt{1 - \delta} i_{Lrms} \end{aligned} \quad (19.7)$$

If the average inductor current, hence output current, is \bar{I}_L , then the maximum and minimum inductor current levels are given by

$$\begin{aligned} \hat{i}_L &= \bar{I}_L + 1/2 \Delta i_L = \bar{I}_o + 1/2 \frac{v_o}{L} (1 - \delta) \tau \\ &= v_o \left[\frac{1}{R} + \frac{(1 - \delta) \tau}{2L} \right] = v_o \left[\frac{1}{R} + \frac{1 - \delta}{2fL} \right] \end{aligned} \quad (19.8)$$

and

$$\begin{aligned} \check{i}_L &= \bar{I}_L - 1/2 \Delta i_L = \bar{I}_o - 1/2 \frac{v_o}{L} (1 - \delta) \tau \\ &= v_o \left[\frac{1}{R} - \frac{(1 - \delta) \tau}{2L} \right] = v_o \left[\frac{1}{R} - \frac{1 - \delta}{2fL} \right] \end{aligned} \quad (19.9)$$

respectively, where Δi_L is given by equation (19.1) or (19.2). The average output current is $\bar{I}_L = 1/2(\hat{i}_L + \check{i}_L) = \bar{I}_o = v_o / R$. The output power is therefore v_o^2 / R , which equals the input power, namely $E_i \bar{I}_i = E_i \bar{I}_T$. Circuit waveforms for continuous inductor current conduction are shown in figure 19.2b.

Switch and converter utilisation ratios

The switch utilisation ratio, SUR , is a measure of how fully a switching device's power handling capabilities are utilised in any switching application. The ratio is defined as

$$SUR = \frac{P_{out}}{p V_T I_T} \quad (19.10)$$

where p is the number of power switches in the circuit; $p=1$ for the forward converter. The switch maximum instantaneous voltage and current are V_T and I_T respectively. As shown in figure 19.2b, the maximum switch voltage supported in the off-state is E_i , while the maximum current is the maximum inductor current \hat{i}_L which is given by equation (19.8). If the inductance L is large such that the ripple

current is small, the peak inductor current is approximated by the average inductor current $I_T \approx \bar{I}_L = \bar{I}_o$, that is

$$SUR = \frac{v_o \bar{I}_o}{1 \times E_i \times \bar{I}_o} = \frac{v_o}{E_i} = \delta \quad (19.11)$$

which assumes continuous inductor current. This result shows that the higher the duty cycle, that is the closer the output voltage v_o is to the input voltage E_i , the better the switch I - V ratings are utilised.

While SUR represents the utilisation of a single switch, the total converter semiconductor utilisation is represented by the factor U_f :

$$U_f = \frac{P_{rated}}{\sum_{i=1}^n V_{max} I_{rms}} = \frac{\delta}{\sqrt{\delta} + \sqrt{\delta'}} \quad (19.12)$$

19.1.2 Discontinuous inductor current (DCM - discontinuous conduction mode)

The onset of discontinuous inductor current operation occurs when the minimum inductor current \check{i}_L , reaches zero. That is, with $\check{i}_L = 0$ in equation (19.9), the last equality

$$\frac{1}{R} - \frac{(1 - \delta)}{2fL} = 0 \quad (19.13)$$

relates circuit component values (R and L) and operating conditions (f and δ) at the verge of discontinuous inductor current. Also, with $\check{i}_L = 0$ in equation (19.9)

$$\bar{I}_L = \bar{I}_o = 1/2 \Delta i_L \quad (19.14)$$

which, after substituting equation (19.1) or equation (19.2), yields

$$\bar{I}_L = \bar{I}_o = \frac{(E_i - v_o)}{2L} \tau \delta \quad \text{or} \quad \frac{E_i}{2L} \tau \delta (1 - \delta) \quad \text{or} \quad \frac{v_o}{2L} \tau (1 - \delta) \quad (19.15)$$

If the transistor on-time t_T is reduced (or the load current is reduced), the discontinuous condition dead time t_x is introduced as indicated in figure 19.2c. From equations (19.1) and (19.2), with $\check{i}_L = 0$, the output voltage transfer function is now derived as follows

$$\hat{i}_L = \frac{(E_i - v_o)}{L} t_T = \frac{v_o}{L} (\tau - t_T - t_x) \quad (19.16)$$

that is

$$\frac{v_o}{E_i} = \frac{\delta}{1 - \frac{t_x}{\tau}} \quad 0 \leq \delta < 1 \quad \text{and} \quad t_x \geq 0 \quad (19.17)$$

This voltage transfer function form may not be particularly useful since the dead time t_x is not expressed in term of circuit parameters. Accordingly, from equation (19.16)

$$\hat{i}_L = \frac{(E_i - v_o)}{L} t_T \quad (19.18)$$

and from the input current waveform in figure 19.2c:

$$\bar{I}_i = 1/2 \hat{i}_L \times \frac{t_T}{\tau} \quad (19.19)$$

Eliminating \hat{i}_L yields

$$\frac{2\bar{I}_i}{\delta} = \left(1 - \frac{v_o}{E_i}\right) \frac{\tau \delta E_i}{L} \quad (19.20)$$

that is

$$\frac{v_o}{E_i} = 1 - \frac{2L\bar{I}_i}{\delta^2 \tau E_i} \quad (19.21)$$

Assuming power-in equals power-out, that is, $E_i \bar{I}_i = v_o \bar{I}_o = v_o \bar{I}_L$, the input average current can be eliminated, and after re-arranging yields:

$$\frac{v_o}{E_i} = \frac{1}{1 + \frac{2L\bar{I}_o}{\delta^2 \tau E_i}} = \frac{1}{1 + \frac{2L\bar{I}_L}{\delta^2 \tau v_o}} \quad (19.22)$$

At a low output current or high input voltage, there is a likelihood of discontinuous inductor conduction. To avoid discontinuous conduction, larger inductance values are needed, which worsen transient response. Alternatively, with extremely low on-state duty cycles, a voltage-matching transformer can be used to increase δ . Once a transformer is used, any smps technique can be used to achieve the desired output voltage. Figures 19.2b and c show that the input current is always discontinuous.

19.1.3 Load conditions for discontinuous inductor current

As the load current decreases, the inductor average current also decreases, but the inductor ripple current magnitude is unchanged. If the load resistance is increased sufficiently, the bottom of the triangular inductor current, \bar{I}_L , eventual reduces to zero. Any further increase in load resistance causes discontinuous inductor current and the linear voltage transfer function given by equation (19.4) is no longer valid and equations (19.17) and (19.21) are applicable. The critical load resistance for continuous inductor current, (19.13), is specified by

$$R_{crit} \leq \frac{V_o}{\bar{I}_o} = \frac{V_o}{\frac{1}{2}\Delta I_L} \quad (19.23)$$

Substitution for v_o from equation (19.2) and using the fact that $\bar{I}_o = \bar{I}_L$, yields

$$R_{crit} \leq \frac{V_o}{\bar{I}_o} = \frac{\Delta I_L L}{\bar{I}_L(\tau - t_T)} \quad (19.24)$$

Eliminating ΔI_L by substituting the limiting condition given by equation (19.14) gives

$$R_{crit} \leq \frac{V_o}{\bar{I}_o} = \frac{\Delta I_L L}{\bar{I}_L(\tau - t_T)} = \frac{2\bar{I}_L L}{\bar{I}_L(\tau - t_T)} = \frac{2L}{(\tau - t_T)} \quad (19.25)$$

Dividing throughout by τ and substituting $\delta = t_T / \tau$ yields

$$R_{crit} \leq \frac{V_o}{\bar{I}_o} = \frac{2L}{(\tau - t_T)} = \frac{2L}{\tau(1 - \delta)} \quad (19.26)$$

The critical resistance can be expressed in a number of forms. By substituting the switching frequency ($f_s = 1/\tau$) or the fundamental inductor reactance ($X_L = 2\pi f_s L$) the following forms result.

$$R_{crit} \leq \frac{V_o}{\bar{I}_o} = \frac{2L}{\tau(1 - \delta)} = \frac{V_o}{E_s} \times \frac{2L}{\tau\delta(1 - \delta)} = \frac{2f_s L}{(1 - \delta)} = \frac{X_L}{\pi(1 - \delta)} \quad (\Omega) \quad (19.27)$$

Rearranged this equation gives L_{min} . Notice that equation (19.27) is in fact equation (19.13), re-arranged. If the load resistance increases beyond R_{crit} , the output voltage can no longer be maintained with duty cycle control according to the voltage transfer function in equation (19.4).

19.1.4 Control methods for discontinuous inductor current

Once the load current has reduced to the critical level as specified by equation (19.27), the input energy is in excess of the load requirement. Open loop load voltage regulation control is lost and the capacitor C tends to overcharge.

Hardware approaches can solve this problem – by producing continuous inductor current

- increase L thereby decreasing the inductor current ripple peak-to-peak magnitude
- step-down transformer impedance matching to effectively reduce the apparent load impedance

Two control approaches to maintain output voltage regulation when $R > R_{crit}$ are

- vary the switching frequency f_s , maintaining the switch on-time t_T constant so that ΔI_L is fixed or
- reduce the switch on-time t_T , but maintain a constant switching frequency f_s , thereby reducing ΔI_L .

If a fixed switching frequency is desired for all modes of operation, then reduced on-time control, using output voltage feedback, is preferred. If a fixed on-time mode of control is used, then the output voltage is control by varying inversely the frequency with output voltage. Alternatively, output voltage feedback can be used.

19.1.4i - fixed on-time t_T , variable switching frequency f_{var}

The operating frequency f_{var} is varied while the switch-on time t_T is maintained constant such that the ripple current remains unchanged. Operation is specified by equating the input energy and the output energy, thus maintaining a constant capacitor charge, hence output voltage. That is, equating energies

$$\frac{1}{2}\Delta I_L E_s t_T = \frac{V_o^2}{R} \frac{1}{f_{var}} \quad (19.28)$$

Isolating the variable switching frequency f_{var} gives

$$\begin{aligned} f_{var} &= \frac{V_o^2}{\frac{1}{2}\Delta I_L E_s t_T} \frac{1}{R} \\ f_{var} &= f_s R_{crit} \times \frac{1}{R} \\ f_{var} &\propto \frac{1}{R} \end{aligned} \quad (19.29)$$

That is, once discontinuous inductor current occurs, if the switching frequency is varied inversely with load resistance and the switch on-state period is maintained constant, output voltage regulation can be maintained.

Load resistance R is not a directly or readily measurable parameter for feedback proposes. Alternatively, since $v_o = \bar{I}_o R$ substitution for R in equation (19.29) gives

$$\begin{aligned} f_{var} &= f_s \frac{R_{crit}}{V_o} \times \bar{I}_o \\ f_{var} &\propto \bar{I}_o \end{aligned} \quad (19.30)$$

That is, for $\bar{I}_o < \frac{1}{2}\Delta I_L$ or $\bar{I}_o < v_o / R_{crit}$, if t_T remains constant and f_{var} is varied proportionally with load current, then the required output voltage v_o will be maintained.

19.1.4ii - fixed switching frequency f_s , variable on-time t_{Tvar}

The operating frequency f_s remains fixed while the switch-on time t_{Tvar} is reduced, resulting in the ripple current being reduced. Operation is specified by equating the input energy and the output energy as in equation (19.28), thus maintaining a constant capacitor charge, hence voltage. That is

$$\frac{1}{2}\Delta I_L E_s t_{Tvar} = \frac{V_o^2}{R} \frac{1}{f_s} \quad (19.31)$$

Isolating the variable on-time t_{Tvar} yields

$$t_{Tvar} = \frac{V_o^2}{\frac{1}{2}\Delta I_L E_s f_s} \frac{1}{R}$$

Substituting ΔI_L from equation (19.2) gives

$$\begin{aligned} t_{Tvar} &= t_T \sqrt{\frac{R_{crit}}{R}} \times \frac{1}{\sqrt{R}} \\ t_{Tvar} &\propto \frac{1}{\sqrt{R}} \end{aligned} \quad (19.32)$$

That is, once discontinuous inductor current commences, if the switch on-time is varied inversely to the square root of the load resistance, maintaining the switching frequency constant, regulation of the output voltage can be maintained.

Again, load resistance R is not a directly or readily measurable parameter for feedback proposes and substitution of v_o / \bar{I}_o for R in equation (19.32) gives

$$\begin{aligned} t_{Tvar} &= t_T \sqrt{\frac{R_{crit}}{v_o}} \times \sqrt{\bar{I}_o} \\ t_{Tvar} &\propto \sqrt{\bar{I}_o} \end{aligned} \quad (19.33)$$

That is, if f_s is fixed and t_T is reduced proportionally to $\sqrt{\bar{I}_o}$, when $\bar{I}_o < \frac{1}{2}\Delta I_L$ or $\bar{I}_o < v_o / R_{crit}$, then the required output voltage magnitude v_o will be maintained.

19.1.5 Output ripple voltage

Three components contribute to the output voltage ripple

- Ripple charging/discharging of the ideal output capacitor, C
- Capacitor equivalent series resistance, ESR
- Capacitor equivalent series inductance, ESL

The capacitor inductance and resistance parasitic series component values decrease as the quality of the capacitor increases. The output ripple voltage is the vectorial summation of the three components that are shown in figure 19.3 for the forward converter.

Ideal Capacitor: The ripple voltage for a capacitor is defined as

$$\Delta v_C = \frac{1}{C} \int i dt = \frac{1}{C} \Delta Q$$

Figures 19.2 and 19.3 show that for continuous inductor current, the inductor current which is the output current, swings by Δi around the average output current, \bar{I}_o , thus

$$\Delta V_C = \frac{1}{C} \int i dt = \frac{1}{2} \frac{\Delta i}{C} \frac{\tau}{2} \quad (19.34)$$

Substituting for Δi_L from equation (19.2)

$$\Delta V_C = \frac{1}{C} \int i dt = \frac{1}{2} \frac{\Delta i}{C} \frac{\tau}{2} = \frac{1}{8} \frac{V_o}{L} \times (\tau - t_r) \tau \quad (19.35)$$

If ESR and ESL are ignored, after rearranging, equation (19.35) gives the percentage voltage ripple (peak to peak) in the output voltage

$$\frac{\Delta V_C}{V_o} = \frac{\Delta V_o}{V_o} = \gamma_8 \frac{1}{LC} \times (1 - \delta) \tau^2 = \frac{1}{2} \pi^2 (1 - \delta) \left(\frac{f_c}{f_s} \right)^2 \quad (19.36)$$

In complying with output voltage ripple requirements, from this equation, the switching frequency $f_s = 1/\tau$ must be much higher than the cut-off frequency given by the forward converter low-pass, second-order LC output filter, $f_c = 1/2\pi\sqrt{LC}$. The voltage switching harmonics before filtering are the dc part δE_i and

$$V_n = \frac{\sqrt{2} E_i}{n\pi} \sqrt{1 - \cos 2\pi n \delta} \quad (19.37)$$

ESR: The equivalent series resistor voltage follows the ripple current, that is, it swings linearly about

$$V_{ESR} = \pm \frac{1}{2} \Delta i \times R_{ESR} \quad (19.38)$$

ESL: The equivalent series inductor voltage is derived from $v = L di / dt$, that is, when the switch is on

$$V_{ESL}^+ = L \Delta i / t_{on} = L \Delta i / \delta \tau \quad (19.39)$$

When the switch is off

$$V_{ESL}^- = -L \Delta i / t_{off} = -L \Delta i / (1 - \delta) \tau \quad (19.40)$$

The total instantaneous ripple voltage is

$$\Delta V_o = \Delta V_C + V_{ESR} + V_{ESL} \quad (19.41)$$

Forming a time domain solution for each component, then differentiating, gives a maximum ripple when

$$t = 2CR_{ESR}(1 - \delta) \quad (19.42)$$

This expression is independent of the equivalent series inductance, which is expected since it is constant during each operational state. If dominant, the inductor will affect the output voltage ripple at the switch turn-on and turn-off instants.

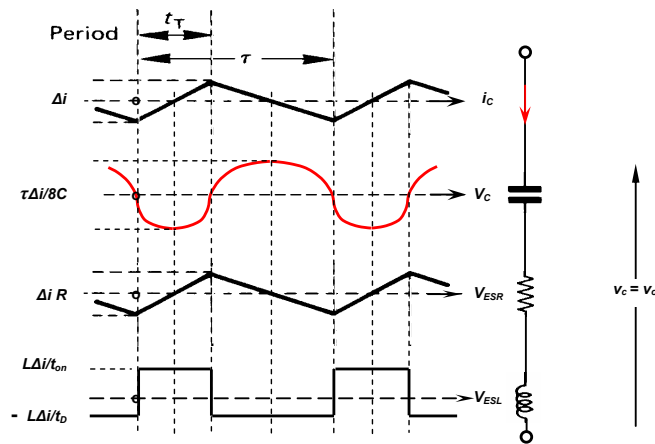

Figure 19.3. Forward converter, three output ripple components, showing: left - voltage components; centre - waveforms; and right - capacitor model.

19.1.6 Apparent load resistance

The apparent or transformed load resistance R_l seen at the input is given by

$$R_l = \frac{E_i}{I_i} = \frac{E_i}{I_i} \times \left(R_o \frac{I_o}{V_o} \right) = \frac{1}{\delta^2} R_o \quad (19.43)$$

That is, the apparent load resistance seen at the input is related to the square of the current transfer function (for all smps operating in a continuous inductor current conduction mode).

Example 19.1: Buck (step-down forward) converter

The step-down converter in figure 19.2a operates at a switching frequency of 10 kHz. The output voltage is to be fixed at 48V dc across a 1Ω resistive load. If the input voltage $E_i = 192V$ and the choke $L = 200\mu H$:

- calculate the switch T on-time duty cycle δ and switch on-time t_r .
- calculate the average load current \bar{I}_o , hence average input current \bar{I}_i .
- draw accurate waveforms for
 - the voltage across, and the current through L ; v_L and i_L
 - the capacitor current, i_C
 - the switch and diode voltage and current; v_T , v_D , i_T , i_D .
 Hence calculate the switch utilisation ratio as defined by equation (19.11).
- calculate the mean and rms current ratings of diode D, switch T and L.
- calculate the capacitor average and rms current, i_{Crms} and output ripple voltage if the capacitor has an internal equivalent series resistance of 20mΩ, assuming $C = \infty$.
- calculate the maximum load resistance R_{crit} before discontinuous inductor current. Calculate the output voltage and inductor non-conduction period, t_x , when the load resistance is triple the critical resistance R_{crit} .
- if the maximum load resistance is 1Ω, calculate
 - the value the inductance L can be reduced, to be on the verge of discontinuous inductor current and for that L
 - the peak-to-peak ripple and rms, inductor and capacitor currents.
- specify two control strategies for controlling the forward converter in a discontinuous inductor current mode.
- output ripple voltage hence percentage output ripple voltage, for $C = 1,000\mu F$ and an equivalent series inductance of ESL = 0.5μH, assuming ESR = 0Ω.
- The apparent load resistance seen at the input, for the duty cycle and load for part i.

Solution

- From equation (19.4), assuming continuous inductor current, the duty cycle δ is

$$\delta = \frac{V_o}{E_i} = \frac{48V}{192V} = \frac{1}{4} = 25\%$$

Also, from equation (19.4), for a 10kHz switching frequency, the switching period τ is 100μs and the transistor on-time t_r is given by

$$\frac{V_o}{E_i} = \frac{t_r}{\tau} = \frac{48V}{192V} = \frac{t_r}{100\mu s}$$

whence the transistor on-time is 25μs and the diode conducts for 75μs.

- The average load current is $\bar{I}_o = \frac{V_o}{R} = \frac{48V}{1\Omega} = 48A = \bar{I}_L$

From power-in equals power-out, the average input current is

$$\bar{I}_i = V_o \bar{I}_o / E_i = 48V \times 48A / 192V = 12A$$

- From equation (19.1) (or equation (19.2)) the inductor peak-to-peak ripple current is

$$\Delta i_L = \frac{E_i - V_o}{L} \times t_r = \frac{192V - 48V}{200\mu H} \times 25\mu s = 18A$$

From part ii, the average inductor current is the average output current, 48A. The inductor current is continuous since $i_L = 39A$. Circuit voltage and current waveforms are shown in the figure to follow.

The circuit waveforms show that the maximum switch voltage and current are 192V and 57A respectively. The switch utilisation ratio is given by equation (19.11), that is

$$SUR = \frac{P_{out}}{E_i \times \hat{i}_o} = \frac{V_o^2 / R}{E_i \times \hat{i}_o} = \frac{48V^2 / 1\Omega}{192V \times 57A} \approx 21\%$$

If the ripple current were assumed small, the resulting SUR value of $\delta = 33\%$ gives a misleading underestimate indication.

iv. Current i_D through diode D is shown on the inductor current waveform. The average diode current is

$$\bar{I}_D = \frac{\tau - t_T}{\tau} \times \bar{I}_L = (1 - \delta) \times \bar{I}_L = (1 - 1/4) \times 48A = 36A$$

The rms diode current is given by

$$i_{D,rms} = \sqrt{\frac{1}{\tau} \int_0^{\tau-t_T} \left(\hat{i}_L - \frac{\Delta i_L}{\tau - t_T} t \right)^2 dt} = \sqrt{\frac{1}{100\mu s} \int_0^{75\mu s} \left(57A - \frac{18A}{75\mu s} t \right)^2 dt} = 41.8A$$

Current i_T through the switch T is shown on the inductor current waveform. The average switch current is

$$\bar{I}_T = \frac{t_T}{\tau} \bar{I}_L = \delta \bar{I}_L = 1/4 \times 48A = 12A$$

Alternatively, from power-in equals power-out

$$\bar{I}_T = \bar{I}_i = V_o \bar{I}_o / E_i = 48V \times 48A / 192V = 12A$$

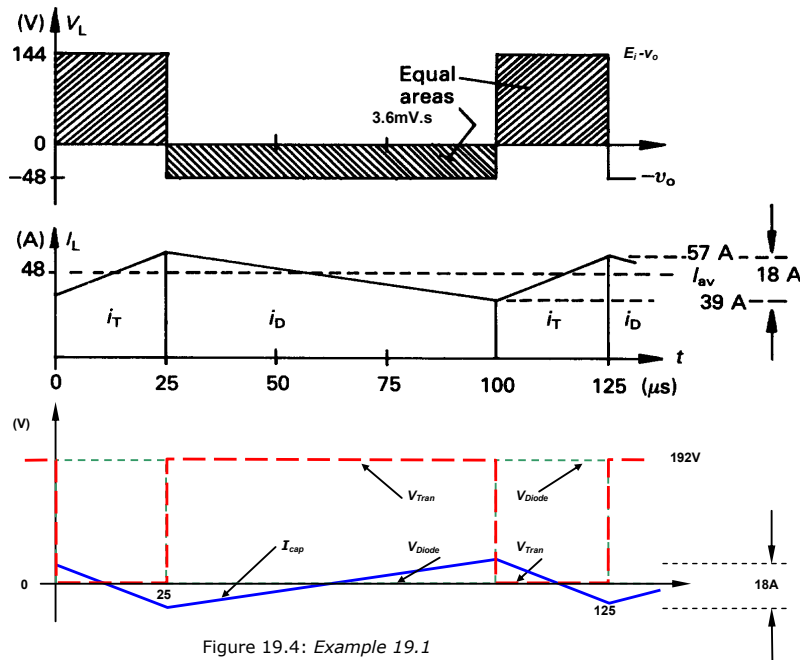

Figure 19.4: Example 19.1

The transistor rms current is given by

$$i_{T,rms} = \sqrt{\frac{1}{\tau} \int_0^{t_T} \left(\hat{i}_L + \frac{\Delta i_L}{t_T} t \right)^2 dt} = \sqrt{\frac{1}{100\mu s} \int_0^{25\mu s} \left(39A + \frac{18A}{25\mu s} t \right)^2 dt} = 24.1A$$

The mean inductor current is the mean output current, $\bar{I}_o = \bar{I}_L = 48A$.

The inductor rms current is given by equation (19.6), that is

$$I_{L,rms} = \sqrt{\bar{I}_L^2 + \left(\frac{1}{2} \frac{\Delta i_L}{\sqrt{3}} \right)^2} = \sqrt{48A^2 + \left(\frac{1}{2} \times \frac{18A}{\sqrt{3}} \right)^2} = 48.3A$$

v. The average capacitor current \bar{I}_C is zero and the rms ripple current is given by

$$i_{C,rms} = \sqrt{\frac{1}{\tau} \left[\int_0^{t_T} \left(-\frac{1}{2} \Delta i_L + \frac{\Delta i_L}{t_T} t \right)^2 dt + \int_0^{\tau-t_T} \left(\frac{1}{2} \Delta i_L - \frac{\Delta i_L}{\tau-t_T} t \right)^2 dt \right]}$$

$$= \sqrt{\frac{1}{100\mu s} \left[\int_0^{25\mu s} \left(-9A + \frac{18A}{25\mu s} t \right)^2 dt + \int_0^{75\mu s} \left(9A - \frac{18A}{75\mu s} t \right)^2 dt \right]}$$

$$= 5.2A \quad (= \Delta i_L / 2\sqrt{3})$$

The capacitor voltage ripple (hence the output voltage ripple), assuming infinite output capacitance, is determined by the capacitor ripple current which is equal to the inductor ripple current, 18A p-p, that is

$$V_{o,ripple} = \Delta i_L \times R_{Cesr} = 18A \times 20m\Omega = 360mV \text{ p-p}$$

and the rms output voltage ripple is

$$V_{o,rms} = i_{C,rms} \times R_{Cesr} = 5.2A \text{ rms} \times 20m\Omega = 104mV \text{ rms}$$

vi. Critical load resistance is given by equation (19.27), namely

$$R_{crit} \leq \frac{V_o}{\bar{I}_o} = \frac{2L}{\tau(1-\delta)}$$

$$= \frac{2 \times 200\mu H}{100\mu s \times (1-1/4)} = 16/3\Omega$$

$$= 5\frac{1}{3}\Omega \text{ when } \bar{I}_o = 9A$$

Alternatively, the critical load current is 9A ($\frac{1}{2} \Delta i_L$), thus from the immediately previous equation, the load resistance must not be greater than $V_o / \bar{I}_o = 48V / 9A = 5\frac{1}{3}\Omega$, if the inductor current is to be continuous. When the load resistance is tripled to 16Ω the output voltage is given by equation (19.21), which is shown normalised in table 19.2. That is

$$V_o = E_i \times 1/4 k \delta^2 \left[-1 + \sqrt{1 + \frac{8}{\delta^2 k}} \right] \text{ where } k = \frac{R\tau}{L} = \frac{16\Omega \times 100\mu s}{200\mu H} = 8 \text{ thus}$$

$$V_o = 192V \times 1/4 \times 8 \times 1/4^2 \times \left[-1 + \sqrt{1 + \frac{8}{1/4^2 \times 8}} \right] = 75V \quad [\hat{i}_L = 14.625A]$$

The inductor current is zero for an interval of the 100μs switching period, and the time is given by the appropriate normalised expression involving t_x for the forward converter in table 19.2 or by equation (19.17), which when re-arranged to isolate t_x becomes

$$t_x = \tau \left(1 - \frac{\delta}{V_o / E_i} \right) = 100\mu s \times \left(1 - \frac{1/4}{75V/50V} \right) = 36\mu s \quad [t_x = 25\mu s \quad t_o = 39\mu s]$$

vii. The critical resistance formula given in equation (19.27) is valid for finding critical inductance when inductance is made the subject of the equation, that is, rearranging equation (19.27) gives

$$L_{crit} = 1/2 \times R \times (1-\delta) \times \tau \quad (H)$$

$$= 1/2 \times 1\Omega \times (1-1/4) \times 100\mu s = 37\frac{1}{2}\mu H$$

This means the inductance can be reduced from 200μH with a 48A mean and 18A p-p ripple current, to 37½μH with the same 48A mean plus a superimposed 96A p-p ($2\bar{I}_L$) ripple current. The rms capacitor current is given by

$$i_{C,rms} = \Delta i_L / 2\sqrt{3} = 96A / 2\sqrt{3} = 27.2A \text{ rms}$$

The inductor rms current requires the following integration

$$i_{L,rms} = \sqrt{\frac{1}{\tau} \left[\int_0^{t_T} \left(\hat{i}_L + \frac{\Delta i_L}{t_T} t \right)^2 dt + \int_0^{\tau-t_T} \left(\hat{i}_L - \frac{\Delta i_L}{\tau-t_T} t \right)^2 dt \right]}$$

$$= \sqrt{\frac{1}{100\mu s} \times \left[\int_0^{25\mu s} \left(0 + \frac{96A}{25\mu s} t \right)^2 dt + \int_0^{75\mu s} \left(96A - \frac{96A}{75\mu s} t \right)^2 dt \right]}$$

$$= 96/\sqrt{3} = 55.4A \text{ rms}$$

or from equation (19.6)

$$i_{L\text{rms}} = \sqrt{\bar{I}_L^2 + I_{L\text{ripple}}^2} = \sqrt{48^2 + (96 / 2\sqrt{3})^2} = 55.4 \text{ A rms}$$

viii. For $R > 16/3\Omega$, or $\bar{I}_o < 9\text{A}$, equations (19.30) or (19.33) can be used to develop a suitable control strategy.

(a) From equation (19.30), using a variable switching frequency of less than 10kHz,

$$f_{\text{var}} = f_s \frac{R_{\text{crit}}}{V_o} \bar{I}_o = 10\text{kHz} \frac{5\frac{1}{3}\Omega}{48\text{V}} \bar{I}_o$$

$$f_{\text{var}} = \frac{10}{9} \times \bar{I}_o \text{ kHz}$$

(b) From equation (19.33), maintaining a fixed switching frequency of 10kHz, the on-time duty cycle is reduced (from 25μs) for $\bar{I}_o < 9\text{A}$ according to

$$t_{r\text{var}} = t_r \sqrt{\frac{R_{\text{crit}}}{V_o}} \sqrt{\bar{I}_o} = 25\mu\text{s} \sqrt{\frac{5\frac{1}{3}\Omega}{48\text{V}}} \sqrt{\bar{I}_o}$$

$$t_{r\text{var}} = \frac{25}{3} \times \sqrt{\bar{I}_o} \mu\text{s}$$

ix. From equation (19.34) the output ripple voltage with an ideal 1,000μF capacitor is given by

$$\Delta V_c = \frac{\Delta i \tau}{8C} = \frac{18\text{A} \times 100\mu\text{s}}{8 \times 1000\mu\text{F}} = 225\text{mV p-p}$$

The voltage produced because of the equivalent series 0.5 μH inductance is

$$V_{\text{ESL}}^+ = L\Delta i / \delta\tau = 0.5\mu\text{H} \times 18\text{A} / 0.25 \times 100\mu\text{s} = 360\text{mV}$$

$$V_{\text{ESL}}^- = -L\Delta i / (1 - \delta)\tau = -0.5\mu\text{H} \times 18\text{A} / (1 - 0.25) \times 100\mu\text{s} = -120\text{mV}$$

Time domain summation of the capacitor and ESL inductor voltages show that the peak to peak output voltage swing is determined by the ESL inductor, giving

$$\Delta V_o = V_{\text{ESL}}^+ - V_{\text{ESL}}^- = 360\text{mV} + 120\text{mV} = 480\text{mV}$$

The percentage ripple in the output voltage is 480mV/48V = 1%.

x. From equation (19.43) the apparent load resistance is

$$R_i = \frac{1}{\delta^2} R_o = \frac{1}{\frac{1}{4}^2} 1\Omega = 16\Omega$$

19.1.6 Underlying operational mechanisms of the forward converter

The inductor current is pivotal to the analysis and understanding of any voltage sourced smps. For analysis, the smps internal and external electrical conditions are in steady-state on a cycle-by-cycle basis and the input power is equal to the output power.

The *first concept* to appreciate is that the net capacitor charge change is zero over each switching cycle. That is, the average capacitor current is zero:

$$\bar{I}_c = \frac{1}{T} \int_t^{t+T} i_c(t) dt = 0$$

In so being, the output capacitor provides any load current deficit and stores any load current (inductor) surplus associated with the inductor current within each complete cycle. Thus, the capacitor is a temporary storage component where the capacitor voltage is fixed on a cycle-by-cycle basis, and because of its large capacitance does not vary significantly within a cycle.

The *second concept* involved is that the average inductor voltage is zero. Based on $v = L di / dt$, the equal area criteria in chapter 13.1.3i,

$$i_{t+\tau} - i_t = \frac{1}{L} \int_t^{t+\tau} v_L(t) dt = 0 \text{ since } i_{t+\tau} = i_t \text{ in steady-state}$$

Thus the average inductor voltage is zero:

$$\bar{V}_L = \frac{1}{T} \int_t^{t+T} v_L(t) dt = 0$$

The most enlightening way to appreciate the converter operating mechanisms is to consider how the inductor current varies with load resistance R and inductance L . The figure 19.5 shows the inductor current associated with the various parts of example 19.1.

For continuous inductor current operation, the two necessary and sufficient equations are $I_o = v_o/R$ and equation (19.2). Since the duty cycle and on-time are fixed for a given output voltage requirement, equation (19.2) can be simplified to show that the ripple current is inversely proportional to inductance, as follows

$$\Delta i_L = \frac{V_o}{L} \times (\tau - t_r) \tag{19.44}$$

$$\Delta i_L \propto \frac{1}{L}$$

Since the average inductor current is equal to the load current, then, at a given output voltage, the average inductor current is inversely proportional to the load resistance, that is

$$\bar{I}_L = \bar{I}_o = v_o / R \tag{19.45}$$

$$\bar{I}_L \propto \frac{1}{R}$$

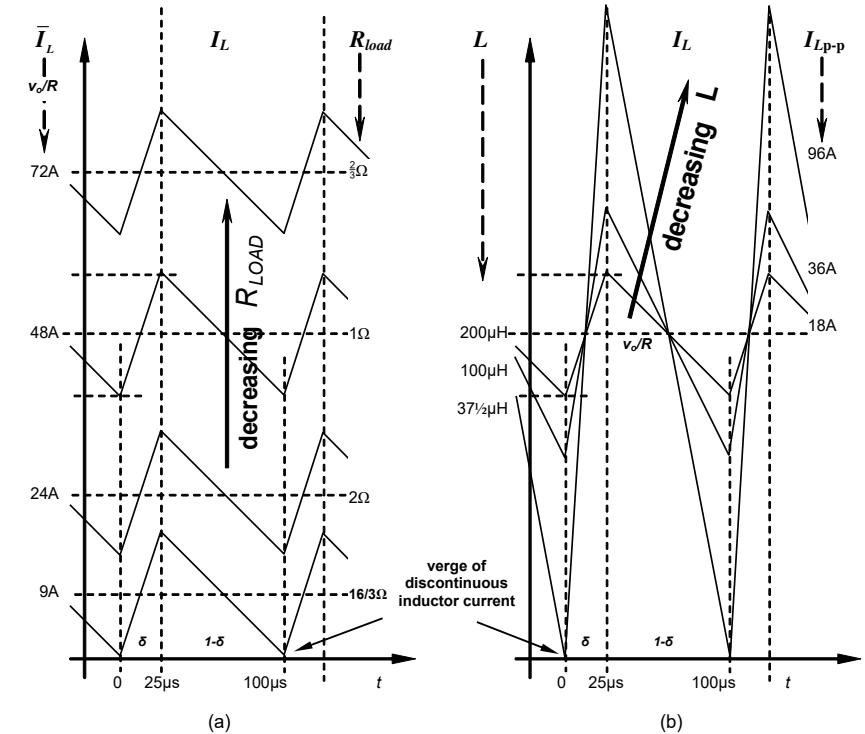

Figure 19.5. Forward converter (buck converter) operational mechanisms showing that: (a) the average inductor current is inversely proportional to load resistance R (fixed L) and (b) the inductor ripple current magnitude is inversely proportional to inductance L (fixed load R).

Equation (19.45) predicts that the average inductor current is inversely proportional to the load resistance, as shown in figure 19.5a. As the load is increased (load resistor decreased), the triangular

inductor current moves vertically up, but importantly, from equation (19.44), the peak-to-peak ripple current is constant, that is the ripple current is independent of the load. As the load current is progressively decreased, by increasing R , the peak-to-peak current is unchanged; the inductor minimum current eventually reduces to zero, and discontinuous inductor current operation occurs.

Equation (19.44) indicates that the inductor ripple current is inversely proportional to inductance, as shown in figure 19.5b. As the inductance is varied the ripple current varies inversely, but importantly, from equation (19.45), the average current is constant, and specifically the average current value is not related to inductance L and is solely determined by the load current, v_o/R . As the inductance decreases the magnitude of the ripple current increases, the average is unchanged, and the minimum inductor current eventually reaches zero and discontinuous inductor current operation results.

19.1.7 Hysteresis voltage feedback control of the forward converter

The main function of a dc-to-dc converter is to provide a regulated output voltage, independent of input voltage or load changes, and it must respond quickly to maintain the output voltage due to any input voltage or load changes. Figure 19.6a shows a hysteresis controller for the buck and forward converters. The comparator compares the output voltage V_o to a reference voltage V_{ref} . If $V_o < V_{ref}$, the switch T_1 is turned off. If $V_o > V_{ref}$, the switch is turned on. This process is repeated continuously such that V_o is maintained at a value close to V_{ref} .

Undesirable high frequency switching action, chattering, is avoided by creating a dead band around V_{ref} . The dead band is created by using an upper boundary V_{upper} and a lower boundary V_{lower} . The region between the two boundaries is the dead band. Resistors R_{fb} and R_{ref} produce the required dead band and their values determine the upper and lower boundaries of the dead band.

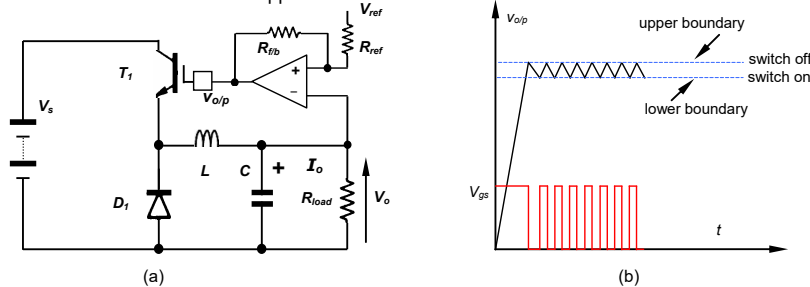

Figure 19.6: The hysteresis controller with a dead band.

The comparator in figure 19.6a is a Schmitt trigger. The input voltage v^+ of the positive op-amp input depends on V_{ref} , $V_{o/p}$, R_{fb} , and R_{ref} . It switches from one boundary of the dead band to the other. During initial start-up of the buck converter, the op-amp negative input v^- is a small positive voltage and is less than v^+ . The amplifier saturates such that $V_{o/p}$ attains the op-amp supply, thus the switch is turned on and v^+ is given by:

$$v^+ = \frac{R_{ref}}{R_{ref} + R_{fb}} V_{o/p} + \frac{R_{fb}}{R_{ref} + R_{fb}} V_{ref} \quad (19.46)$$

Progressively the output voltage V_o increases. The op-amp output voltage, $V_{o/p}$, remains unchanged until V_o is equal to v^+ . The op-amp then enters its linear region and $V_{o/p}$ decreases, as does v^+ . This continues until $V_{o/p}$ reaches zero and the op-amp saturates again. The voltage v^+ is now given by:

$$v^+ = \frac{R_{fb}}{R_{ref} + R_{fb}} V_{ref} \quad (19.47)$$

Equations (19.46) and (19.47) represent the control boundaries of the control circuit where equation (19.46) defines the upper boundary and equation (19.47) gives the lower boundary of the dead band. The dead band is derived by subtracting equations (19.47) and (19.46), and is given by equation (19.48)

$$\Delta D_{band} = \frac{R_{fb}}{R_{ref} + R_{fb}} V_{o/p} \quad (19.48)$$

R_{fb} and R_{ref} are chosen to give the required $\Delta D_{band}/V_{o/p}$.

When the output voltage V_o is inside the dead band, the switch is off. Regardless of where the voltage starts, switching starts as soon as a boundary is traversed. In figure 19.6b the converter start-up process is illustrated. The switch T_1 turns on initially because the output voltage V_o is below the turn-on

boundary, V_{lower} . The output voltage rises from zero to V_{upper} at a rate limited by the inductor L , the capacitor C , and the load. The switch then turns off as the output voltage crosses the upper boundary V_{upper} and remains off until the output voltage falls crosses below the lower boundary V_{lower} where the switch is turned on. Once the voltage is between the boundaries, within the hysteresis bounds, on-off switching action attempts to maintain the current within the boundaries under all conditions.

System operation becomes independent of the input, the load, the inductor, and the capacitor values. The system tracks the desired voltage V_{ref} even if the component values or the load changes drastically. A drawback is that the controller gives rise to an overvoltage during start-up. This problem can be solved by the correct selection of the inductance and capacitance values that allow the output voltage to rise exponentially and settle somewhat close to the desired output voltage, while maintaining the desired ripple voltage. In power electronics terms, the major limitation is possible broadband EMC generation due to a widely varying switching frequency. The closer the hysteresis bounds, the higher the upper frequency, the wider the frequency variation.

Design Procedure

In the steady-state, the converter output voltage depends on the input voltage V_s , the switching frequency f_s , and the on duration of the switching period t_{on} and is given by equation (19.4):

$$V_o = t_{on} f_s V_s = \delta V_s$$

The product $t_{on} \times f_s$ is defined as the duty ratio δ . The output voltage V_o is regulated by changing δ while f_s is kept constant. This pulse width modulation method is widely used in dc-dc converters.

Another approach to regulate V_o is to vary f_s , keeping δ constant. However, this is undesirable because it is difficult to filter the wide bandwidth ripple in the input and output signals of the converter.

Hysteresis control of the buck converter is fixed boundary control. V_o is regulated by the switching action of the switch T_1 as the output V_o crosses the upper or the lower boundary of the hysteresis dead band. In hysteresis control, f_s and δ are not fixed, but change with the converter conditions. For a given set of converter parameters, both f_s and δ are determined by the hysteresis boundaries, thus frequency f_s and the duty ratio δ are not control parameters in the design of hysteresis controllers. No matter what type of control is used, the basic operating principles of the buck converter do not change. The converter output voltage ripple depends on the dead band of the controller. As the dead band increases (or decreases), the output voltage ripple increases (or decreases) in conjunction with the switching frequency decreasing (or increasing). The voltage ripple specification can be ensured by setting the dead band of the controller at 50% of the ripple specifications with a suitable inductance value.

A properly designed hysteresis controller has excellent steady-state and dynamic properties. It responds quickly to step voltage set point changes. Fixed boundary controllers are stable under extreme disturbance conditions and can be chosen to guarantee ripple specifications or other converter operating constraints.

Example 19.2: Hysteresis controlled buck converter

A dc-dc buck converter is to be regulated with voltage-based hysteresis control. The output voltage $V_o = 5V$ and the load varies between 1 and 5Ω. The input voltage V_s also varies between 16V and 24V with a nominal value of 20V. The maximum ripple voltage is to be limited to $\pm 1\%$ and the nominal switching frequency is $f_s = 100kHz$.

Design to necessary controller and specify the converter L and C values.

Solution

The output voltage ripple is

$$\frac{\Delta V_o}{V_o} = 2\%$$

$$\Delta V_o = 0.02 \times 5V = 0.1V$$

To fulfil the required voltage ripple specification, the hysteresis band is chosen to be 50% of the output voltage ripple to account for an increase in the ripple magnitude due to the natural response of the converter RLC circuit, after the switch is turned off. The hysteresis band is

$$\Delta D_{band} = 0.5 \times 0.1V = 0.05V$$

Solving equation (19.48) for R_{fb} :

$$R_{fb} = R_{ref} \left(\frac{V_o}{\Delta D_b} - 1 \right)$$

Let $R_{ref} = 100\Omega$ and $v_o = 10V$. Then R_{fb} is

$$R_{fb} = 100 \left(\frac{10V}{0.05V} - 1 \right) = 19.9k\Omega$$

These resistances produce a hysteresis band that fulfils the output ripple requirement. The maximum and minimum values of the load current are

$$I_o = \frac{V_o}{R_{\min}} = \frac{5V}{1\Omega} = 5A$$

and

$$\check{I}_o = \frac{V_o}{R_{\max}} = \frac{5V}{5\Omega} = 1A$$

Let the inductor current and the capacitor voltage swings be 10%. The inductor must limit the current swing at maximum load. The total current swing is as follows. Since

$$\frac{\Delta I_L}{I_o} = 10\%$$

$$\Delta I_L = 0.1 \times 5A = 0.5A$$

The capacitor voltage swing is

$$\frac{\Delta V_c}{\Delta V_o} = 10\%$$

$$\Delta V_c = 0.1 \times 0.1V = 0.01V$$

Since the waveform of the output ripple voltage is approximately sinusoidal, accounting for the equivalent series resistance, ESR, of the capacitor C, the output ripple voltage is then

$$\Delta V_o = \sqrt{\Delta V_c^2 + \Delta V_{ESR}^2}$$

where ΔV_{ESR} is the voltage ripple across the capacitor resistance R_{ESR} . The ΔV_{ESR} is usually much greater than ΔV_c , thus a close approximation of the peak-to-peak output voltage ripple is:

$$\begin{aligned} \Delta V_o &\cong \Delta V_{ESR} \\ &\cong \Delta I_c R_{ESR} \cong (\Delta I_L - \Delta I_R) R_{ESR} \end{aligned} \quad (19.49)$$

With the result for ΔI_L , the inductor L is

$$L = \frac{V_o(V_s - V_o)}{V_s f_s \Delta I_L} = \frac{5V(20V - 5V)}{20V \times 100kHz \times 0.5A} = 75\mu H$$

The capacitance is

$$C = \frac{\Delta I_L}{8f_s \Delta V_c} = \frac{0.5A}{8 \times 100kHz \times 0.01V} = 62.5\mu F \cong 68\mu F$$

The ESR of the capacitor can be determined from equation (19.49):

$$R_{ESR} = \frac{\Delta V_o}{\Delta I_L - \Delta I_R} = \frac{0.1V}{0.5A - 0.1A} = \frac{1}{4}\Omega$$

Transient overshoot, undershoot, and recovery time to step load and input changes are important performance parameters in buck converters. Since the current in the inductor cannot change instantaneously, the transient response is inherently inferior to that of linear regulators. The recovery time to step changes in the line and the load is controlled by the characteristic of the controller feedback loop. Transient overshoot and undershoot resulting from step load changes can be analyzed and calculated as follows. The ac output impedance is

$$Z_{out} = \frac{V_s - V_o}{\Delta I_{load}}$$

Since

$$V_L = -L \frac{di_L}{dt} \quad \text{and} \quad I_o = C \frac{dv}{dt}$$

thus

$$Z_{out} = \frac{LI_o}{(V_s - V_o)C}$$

As a result, for an increasing load current, from 1A to 5A, the change in the output voltage (transient undershoot) is:

$$\begin{aligned} \Delta \check{V}_o &= \Delta I_o Z_{out} = \frac{L \Delta I_o^2}{(V_s - V_o)C} \\ &= \frac{75\mu H \times (5A - 1A)^2}{(20V - 5V) \times 68\mu F} = 1.231 \end{aligned}$$

and for a decreasing load current, from 5A to 1A, the change in the output voltage (transient overshoot) is

$$\begin{aligned} \Delta V_o &= \frac{LI_o^2}{V_o C} \\ &= \frac{75\mu H \times (5A - 1A)^2}{5V \times 68\mu F} = 3.69V \end{aligned}$$

19.2 Flyback converters

Flyback converters store energy in an inductor, ('choke'), before transferring any energy to the load and output capacitor such that controllable output voltage magnitudes in excess of the input voltage are attainable. The key characteristic is that whilst energy is being transferred to the inductor, load energy is provided by the output capacitor. Such converters are also known as *ringing choke* converters.

Two basic (minimum component count and transformerless) versions of the flyback converter are possible, both are integral to the same underlying fundamental circuit configuration (see section 19.5): both exist concurrently in the one circuit.

- The step-up voltage flyback converter, called the *boost converter*, where the input and output voltage have the same polarity - non-inversion, and $v_o \geq E_i$.
- The step-up/step-down voltage flyback converter, called the *buck-boost converter*, (technically *boost-buck*) where output voltage polarity inversion occurs, that is $|v_o| \geq 0$.

19.3 The boost converter

The *boost converter* transforms a dc voltage input to a dc voltage output that is greater in magnitude but has the same relative polarity as the input. The basic circuit configuration is shown in figure 19.7a. It will be seen that when the transistor is off, the output capacitor is charged to the input voltage E_i . Inherently, the output voltage v_o can never be less than the input voltage level.

When the transistor T is turned on, the supply voltage E_i is applied across the inductor L and the diode D is reverse-biased by the output voltage v_o . Energy is transferred from the supply to L and when the transistor is turned off this energy is transferred to the load and output capacitor through D. While the inductor is transferring its stored energy to C and the load, energy is also provided from the input source.

The output current is always discontinuous, but the input current can be either continuous or discontinuous. For analysis, assume $v_o > E_i$ and a constant input and output voltage. Inductor currents are then linear and vary according to $v = L di/dt$.

19.3.1 Continuous inductor current (CCM - continuous conduction mode)

The circuit voltage and current waveforms for continuous inductor conduction (CCM) are shown in figure 19.7b. The inductor current excursion, from $v = L di/dt$, which is the input current excursion, during the switch on-time t_T and switch off-time $\tau - t_T$, assuming $v_o \geq E_i$, is given by

$$\Delta i_L = \frac{(v_o - E_i)}{L} (\tau - t_T) = \frac{E_i t_T}{L} \quad (19.50)$$

After rearranging, the voltage and current transfer function is given by

$$\frac{v_o}{E_i} = \frac{\check{I}_L}{\check{I}_o} = \frac{1}{1 - \delta} \quad (19.51)$$

where $\delta = t_T/\tau$, t_T is the transistor on-time, and $P_m = P_{out}$, that is, $E_i I_i = v_o I_o$ is assumed.

The maximum inductor current, which is the maximum input current, \hat{i}_L , using equation (19.50) and $v_o = I_o R$, is given by

$$\begin{aligned} \hat{i}_L &= \check{I}_L + \frac{1}{2} \Delta i_L = \check{I}_L + \frac{1}{2} \frac{E_i t_T}{L} \\ &= \frac{\check{I}_o}{1 - \delta} + \frac{1}{2} \frac{v_o}{L} (1 - \delta) \delta \tau = v_o \left[\frac{1}{(1 - \delta) R} + \frac{(1 - \delta) \delta \tau}{2L} \right] \end{aligned} \quad (19.52)$$

while the minimum inductor current, \hat{y}_L is given by

$$\begin{aligned} \hat{y}_L &= \bar{I}_L - \frac{1}{2} \Delta I_L = \bar{I}_L - \frac{1}{2} \frac{E_i t_r}{L} \\ &= \frac{\bar{I}_o}{1-\delta} - \frac{1}{2} \frac{V_o}{L} (1-\delta) \delta \tau = V_o \left[\frac{1}{(1-\delta)R} - \frac{(1-\delta) \delta \tau}{2L} \right] \end{aligned} \quad (19.53)$$

For continuous conduction $\hat{y}_L \geq 0$, that is, from equation (19.53)

$$\bar{I}_L \geq \frac{1}{2} \frac{E_i t_r}{L} = \frac{1}{2} \frac{V_o (1-\delta) \tau}{L} \quad (19.54)$$

The inductor rms ripple current (and input ripple current in this case) is given by

$$i_{Lr} = \frac{\Delta I_L}{2\sqrt{3}} = \frac{1}{2\sqrt{3}} \frac{V_o}{L} (1-\delta) \delta \tau \quad (19.55)$$

The harmonic components in the input current are

$$I_m = \frac{\sqrt{2} E_i \tau \sin n\delta\pi}{2\pi^2 n^2 (1-\delta)L} = \frac{\sqrt{2} V_o \tau \sin n\delta\pi}{2\pi^2 n^2 L} \quad (19.56)$$

while the inductor total rms current is

$$i_{Lrms} = \sqrt{\bar{I}_L^2 + i_{Lr}^2} = \sqrt{\bar{I}_L^2 + \left(\frac{1}{2\sqrt{3}} \frac{V_o \delta \tau}{L} \right)^2} = \sqrt{\frac{1}{2} \left(\hat{I}_L^2 + \hat{I}_L \times \hat{y}_L + \hat{y}_L^2 \right)} \quad (19.57)$$

The switch and diode average and rms currents are given by

$$\begin{aligned} \bar{I}_T &= \bar{I}_L - \bar{I}_o = \delta \bar{I}_L = \delta \bar{I}_L & I_{Trms} &= \sqrt{\delta} i_{Lrms} \\ \bar{I}_D &= (1-\delta) \bar{I}_L = \bar{I}_o & I_{Drms} &= \sqrt{1-\delta} i_{Lrms} \end{aligned} \quad (19.58)$$

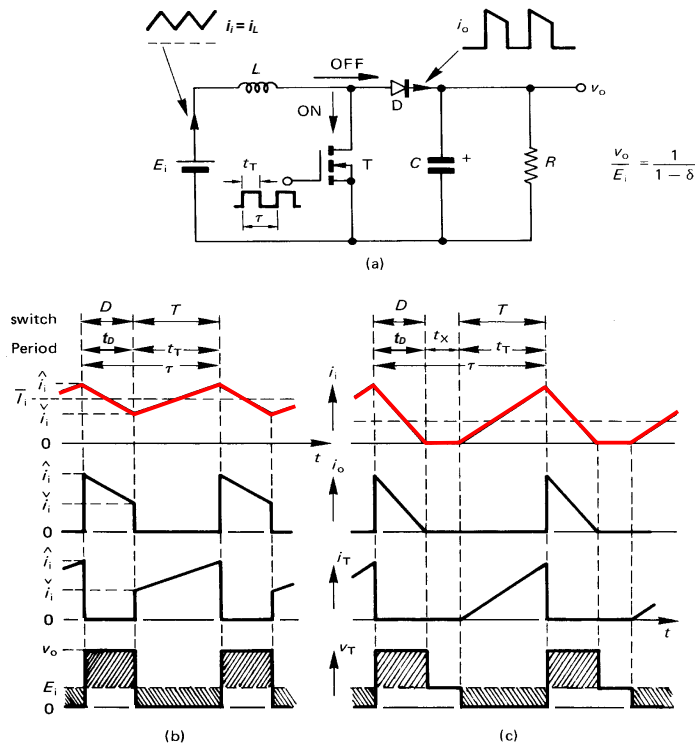

Figure 19.7. Non-isolated, step-up, flyback converter (boost converter) where $v_o \geq E_i$: (a) circuit diagram; (b) continuous input current; and (c) discontinuous input current waveforms.

Switch and converter utilisation ratios

The switch utilisation ratio, SUR, is a measure of how fully a switching device's power handling capabilities are utilised in any switching application. The ratio is defined as

$$SUR = \frac{P_{out}}{p V_T I_T} \quad (19.59)$$

where p is the number of power switches in the circuit; $p=1$ for the boost converter. The switch maximum instantaneous voltage and current are V_T and I_T respectively. As shown in figure 19.7b, the maximum switch voltage supported in the off-state is v_o , while the maximum current is the maximum inductor current \hat{I}_L which is given by equation (19.52). If the inductance L is large such that the ripple current is small, the peak inductor current is approximated by the average inductor current such that $I_T \approx \bar{I}_L = \bar{I}_o / (1-\delta)$, that is

$$SUR = \frac{V_o \bar{I}_o}{V_o \times \bar{I}_o / (1-\delta)} = 1-\delta \quad (19.60)$$

which assumes continuous inductor current. This result shows that the lower the duty cycle, that is the closer the step-up voltage v_o is to the input voltage E_i , the better the switch I - V ratings are utilised. The total converter semiconductor utilisation is represented by the factor U_f :

$$U_f = \frac{P_{rated}}{\sum_{VSI} V_{max} I_{rms}} = \frac{\delta'}{\sqrt{\delta} + \sqrt{\delta'}} \quad (19.61)$$

19.3.2 Discontinuous capacitor charging current in the switch off-state

It is possible that the input current (inductor current) falls below the output (resistor) current during a part of the cycle when the switch is off and the inductor is transferring energy to the output circuit. Under such conditions, towards the end of the off period, part of the load current requirement is provided by the capacitor even though this is the period during which its charge is replenished by inductor energy. The circuit independent transfer function in equation (19.51) remains valid. This C discontinuous charging condition commences when the minimum inductor current \hat{y}_L and the output current I_o are equal. That is

$$\begin{aligned} \hat{y}_L - \bar{I}_o &\leq 0 \\ \bar{I}_L - \frac{1}{2} \Delta I_L - \bar{I}_o &\leq 0 \\ \frac{\bar{I}_o}{1-\delta} - \frac{1}{2} \frac{E_i \delta \tau}{L} - \bar{I}_o &\leq 0 \end{aligned} \quad (19.62)$$

which yields

$$\delta \leq 1 - \sqrt{\frac{2L}{\tau R}} \quad (19.63)$$

19.3.3 Discontinuous inductor current (DCM - discontinuous conduction mode)

If the inequality in equation (19.54) is not satisfied, the input current, which is also the inductor current, reaches zero and discontinuous inductor conduction occurs during the switch off period. Various circuit voltage and current waveforms for discontinuous inductor conduction are shown in figure 19.7c.

The onset of discontinuous inductor operation occurs when the minimum inductor current \hat{y}_L reaches zero. That is, with $\hat{y}_L = 0$ in equation (19.53), the last equality

$$\frac{1}{(1-\delta)R} - \frac{(1-\delta) \delta \tau}{2L} = 0 \quad (19.64)$$

relates circuit component values (R and L) and operating conditions (f and δ) at the verge of discontinuous inductor current.

With $\hat{y}_L = 0$, the output voltage is determined as follows

$$\hat{I}_L = \frac{E_i t_r}{L} = \frac{(V_o - E_i)}{L} (\tau - t_r - t_x) \quad (19.65)$$

yielding

$$\frac{V_o}{E_i} = \frac{1 - \frac{t_x}{\tau}}{1 - \frac{t_x}{\tau} - \delta} \quad (19.66)$$

Alternatively, using

$$\hat{i}_L = \frac{E_i t_T}{L}$$

and

$$\bar{I}_L - \bar{I}_o = \frac{1}{2} \delta \hat{i}_L$$

yields

$$\frac{2}{\delta} (\bar{I}_L - \bar{I}_o) = \frac{E_i t_T}{L}$$

Assuming power-in equals power-out and $\bar{I}_L = \bar{I}_i$

$$\frac{2}{\delta} \bar{I}_o \left(\frac{V_o}{E_i} - 1 \right) = \frac{E_i t_T}{L}$$

that is

$$\frac{V_o}{E_i} = 1 + \frac{E_i \tau \delta^2}{2L \bar{I}_o} = 1 + \frac{V_o \tau \delta^2}{2L \bar{I}_i} \quad (19.67)$$

or

$$\frac{V_o}{E_i} = \frac{1}{1 - \frac{E_i \tau \delta^2}{2L \bar{I}_i}} \quad (19.68)$$

On the verge of discontinuous conduction (when equation (19.51) is valid), these equations can be rearranged to give

$$\bar{I}_o = \frac{E_i}{2L} \tau \delta (1 - \delta) \quad (19.69)$$

At a low output current or low input voltage, there is a likelihood of discontinuous inductor current conduction. (See appendix 20.5.) To avoid discontinuous conduction, larger inductance values are needed, which worsen the transient response. Alternatively, with extremely high on-state duty cycles, (because of a low input voltage E_i) a voltage-matching step-up transformer can be used to decrease δ . Figures 19.7b and c show that the output current is always discontinuous, independent of continuous or discontinuous inductor conduction.

19.3.4 Load conditions for discontinuous inductor current

As the load current decreases, the inductor average current also decreases, but the inductor ripple current magnitude is unchanged. If the load resistance is increased sufficiently, the bottom of the triangular inductor current, \hat{i}_L , eventually reduces to zero. Any further increase in load resistance causes discontinuous inductor current and the voltage transfer function given by equation (19.51) is no longer valid and equations (19.66) and (19.67) are applicable. (Certain circuit parameter values - L , R , and τ - can avoid discontinuous conduction for all δ . See appendix 20.5.) The critical load resistance for continuous inductor current is specified by

$$R_{crit} \leq \frac{V_o}{\bar{I}_o} \quad (19.70)$$

Eliminating the output current by using the fact that power-in equals power-out and $\bar{I}_i = \bar{I}_L$, yields

$$R_{crit} \leq \frac{V_o}{\bar{I}_o} = \frac{V_o^2}{E_i \bar{I}_L} \quad (19.71)$$

Using $\bar{I}_L = \frac{1}{2} \delta \hat{i}_L$ then substituting with the right hand equality of equation (19.50), halved, gives

$$R_{crit} \leq \frac{V_o}{\bar{I}_o} = \frac{V_o^2}{E_i \bar{I}_L} = \frac{V_o^2 2L}{E_i^2 t_T} = \frac{2L}{\tau \delta (1 - \delta)^2} \quad (19.72)$$

The critical resistance can be expressed in a number of forms. By substituting the switching frequency ($f_s = 1 / \tau$) or the fundamental inductor reactance ($X_L = 2\pi f_s L$) the following forms result.

$$R_{crit} \leq \frac{V_o}{\bar{I}_o} = \frac{2L}{\tau \delta (1 - \delta)^2} = \frac{V_o}{E_i} \times \frac{2L}{\tau \delta (1 - \delta)} = \frac{2f_s L}{\delta (1 - \delta)^2} = \frac{X_L}{\pi \delta (1 - \delta)^2} \quad (\Omega) \quad (19.73)$$

Rearranged this equation gives L_{min} . Equation (19.73) is equation (19.64), re-arranged.

If the load resistance increases beyond R_{crit} , generally the output voltage can no longer be maintained with purely duty cycle control according to the voltage transfer function in equation (19.51).

19.3.5 Control methods for discontinuous inductor current

Once the load current has reduced to the critical level as specified by equation (19.73), the input energy is in excess of the load requirement. Open loop load voltage regulation control is lost and the capacitor C tends to overcharge, thereby increasing v_o .

Hardware approaches can be used to solve this problem - by ensuring continuous inductor current

- increase L thereby decreasing the inductor current ripple p-p magnitude
- step-down transformer impedance matching to effectively reduce the apparent load impedance

Two control approaches to maintain output voltage regulation when $R > R_{crit}$ are

- vary the switching frequency f_s , maintaining the switch on-time t_T constant so that Δi_L is fixed or
- reduce the switch on-time t_T , but maintain a constant switching frequency f_s , thereby reducing Δi_L .

If a fixed switching frequency is desired for all modes of operation, then reduced on-time control, using output voltage feedback, is preferred. If a fixed on-time mode of control is used, then the output voltage is control by inversely varying the frequency with output voltage. Alternatively, output voltage feedback can be used.

19.3.5i - fixed on-time t_T , variable switching frequency f_{var}

The operating frequency f_{var} is varied while the switch-on time t_T is maintained constant such that the ripple current remains unchanged. Operation is specified by equating the input energy and the output energy, thus maintaining a constant capacitor charge, hence output voltage. That is, equating energies

$$\frac{1}{2} \Delta i_L E_i \tau = \frac{V_o^2}{R} \frac{1}{f_{var}} \quad (19.74)$$

Isolating the variable switching frequency f_{var} gives

$$f_{var} = \frac{V_o^2}{\frac{1}{2} \Delta i_L E_i \tau} \frac{1}{R} = f_s R_{crit} \times \frac{1}{R} \quad (19.75)$$

$$f_{var} \propto \frac{1}{R}$$

Load resistance R is not a directly or readily measurable parameter for feedback proposes. Alternatively, since $V_o = \bar{I}_o R$, substitution for R in equation (19.75) gives

$$f_{var} = f_s \frac{R_{crit}}{V_o} \times \bar{I}_o \quad (19.76)$$

$$f_{var} \propto \bar{I}_o$$

That is, for discontinuous inductor current, namely $\bar{I}_i < \frac{1}{2} \delta \hat{i}_L$ or $\bar{I}_o < V_o / R_{crit}$, if the switch on-state period t_T remains constant and f_{var} is either varied proportionally with load current or varied inversely with load resistance, then the required output voltage V_o will be maintained.

19.3.5ii - fixed switching frequency f_s , variable on-time t_{Tvar}

The operating frequency f_s remains fixed while the switch-on time t_{Tvar} is reduced such that the ripple current can be reduced. Operation is specified by equating the input energy and the output energy as in equation (19.74), thus maintaining a constant capacitor charge, hence output. That is

$$\frac{1}{2} \Delta i_L E_i t_{Tvar} = \frac{V_o^2}{R} \frac{1}{f_s} \quad (19.77)$$

Isolating the variable on-time t_{Tvar} gives

$$t_{Tvar} = \frac{V_o^2}{\frac{1}{2} \Delta i_L E_i f_s} \frac{1}{R}$$

Substituting Δi_L from equation (19.50) gives

$$t_{Tvar} = t_T \sqrt{R_{crit}} \times \frac{1}{\sqrt{R}} \quad (19.78)$$

$$t_{Tvar} \propto \frac{1}{\sqrt{R}}$$

Again, load resistance R is not a directly or readily measurable parameter for feedback proposes and substitution of V_o / \bar{I}_o for R in equation (19.78) gives

$$t_{T\text{ var}} = t_T \sqrt{\frac{R_{\text{crit}}}{V_o}} \times \sqrt{\bar{I}_o} \quad (19.79)$$

$$t_{T\text{ var}} \propto \sqrt{\bar{I}_o}$$

That is, if the switching frequency f_s is fixed and switch on-time t_T is reduced proportionally to $\sqrt{\bar{I}_o}$ or inversely to \sqrt{R} , when discontinuous inductor current commences, namely $\bar{I}_L < 1/2\Delta I_L$ or $\bar{I}_o < v_o / R_{\text{crit}}$, then the required output voltage magnitude v_o will be maintained.

19.3.6 Output ripple voltage

The output ripple voltage is the capacitor ripple voltage. The ripple voltage for a capacitor is defined as

$$\Delta V_o = \frac{1}{C} \int i dt = \frac{1}{C} \Delta Q$$

Figure 19.7 shows that for continuous inductor current, the constant output current \bar{I}_o is provided solely from the capacitor during the period t_T when the switch is on, thus

$$\Delta V_o = \frac{1}{C} \int i dt = \frac{1}{C} t_T \bar{I}_o$$

Substituting for $\bar{I}_o = v_o / R$ gives

$$\Delta V_o = \frac{1}{C} \int i dt = \frac{1}{C} t_T \bar{I}_o = \frac{1}{C} t_T \frac{v_o}{R}$$

Rearranging gives the percentage voltage ripple (peak to peak) in the output voltage

$$\frac{\Delta V_o}{V_o} = \frac{\delta \tau}{RC} \quad (19.80)$$

The capacitor equivalent series resistance and inductance can be account for, as with the forward converter, 19.1.4. When the switch conducts, the output current is constant and is provided from the capacitor. Thus no ESL voltage effects result during this constant capacitor current portion of the cycle.

Example 19.3: Boost (step-up flyback) converter

The boost converter in figure 19.7 is to operate with a $50\mu\text{s}$ transistor fixed on-time in order to convert the 50 V input up to 75 V at the output. The inductor is $250\mu\text{H}$ and the resistive load is 2.5Ω .

- Calculate the switching frequency, hence transistor off-time, assuming continuous inductor current.
- Calculate the mean input and output current.
- Draw the inductor current, showing the minimum and maximum values.
- Calculate the capacitor rms ripple current.
- Derive general expressions relating the operating frequency to varying load resistance.
- At what load resistance does the instantaneous input current fall below the output current.

Solution

- From equation (19.51), which assumes continuous inductor current

$$\frac{V_o}{E_i} = \frac{1}{1-\delta} \quad \text{where} \quad \delta = \frac{t_T}{\tau}$$

that is

$$\frac{75\text{V}}{50\text{V}} = \frac{1}{1-\delta} \quad \text{where} \quad \delta = \frac{50\mu\text{s}}{\tau} = \frac{1}{3}$$

That is, $\tau = 150\mu\text{s}$ or $f_s = 1/\tau = 6.66\text{ kHz}$, with a $100\mu\text{s}$ switch off-time.

- The mean output current \bar{I}_o is given by

$$\bar{I}_o = v_o / R = 75\text{V}/2.5\Omega = 30\text{A}$$

From power transfer considerations, the average input current is

$$\bar{I}_i = \bar{I}_L = v_o \bar{I}_o / E_i = 75\text{V} \times 30\text{A}/50\text{V} = 45\text{A}$$

- From $v = L di/dt$, the ripple current $\Delta i_L = E_i t_T / L = 50\text{V} \times 50\mu\text{s} / 250\mu\text{H} = 10\text{ A}$

that is

$$\hat{i}_L = \bar{I}_L + 1/2\Delta i_L = 45\text{A} + 1/2 \times 10\text{A} = 50\text{A}$$

$$\check{i}_L = \bar{I}_L - 1/2\Delta i_L = 45\text{A} - 1/2 \times 10\text{A} = 40\text{A}$$

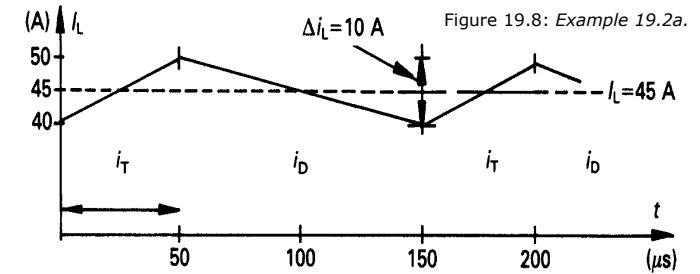

- The capacitor current is derived by using Kirchhoff's current law such that at any instant in time, the diode current, plus the capacitor current, plus the 30A constant load current into R , all sum to zero.

$$i_{\text{cms}} = \sqrt{\frac{1}{\tau} \left[\int_0^{t_T} \bar{I}_o^2 dt + \int_0^{t-T} \left(\frac{\Delta I_L}{\tau - t_T} t - \hat{i}_L + \bar{I}_o \right)^2 dt \right]}$$

$$= \sqrt{\frac{1}{150\mu\text{s}} \left[\int_0^{50\mu\text{s}} 30\text{A}^2 dt + \int_0^{100\mu\text{s}} \left(\frac{10\text{A}}{100\mu\text{s}} t - 20\text{A} \right)^2 dt \right]} = 21.3\text{A}$$

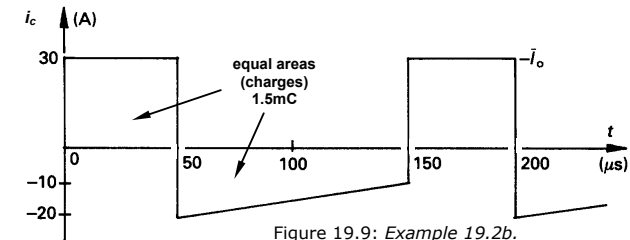

Figure 19.9: Example 19.2b.

- The critical load resistance, R_{crit} , produces an input current with $\Delta i_L = 10\text{ A}$ ripple. Since the energy input equals the energy output

$$1/2\Delta i_L \times E_i \times \tau = v_o \times v_o / R_{\text{crit}} \times \tau$$

that is

$$R_{\text{crit}} = \frac{2v_o^2}{E_i \Delta i_L} = \frac{2 \times 75\text{V}^2}{50\text{V} \times 10\text{A}} = 22\frac{1}{2}\Omega$$

Alternatively, equation (19.73) or equation (19.54) can be rearranged to give R_{crit} .

For a load resistance of less than $22\frac{1}{2}\Omega$, continuous inductor current flows and the operating frequency is fixed at 6.66 kHz with $\delta = 1/3$, that is

$$f_s = 6.66\text{ kHz for all } R \leq 22\frac{1}{2}\Omega$$

For load resistance greater than $22\frac{1}{2}\Omega$, ($< v_o / R_{\text{crit}} = 3\frac{1}{2}\text{A}$), the energy input occurs in $150\mu\text{s}$ burst whence from equation (19.74)

$$1/2\Delta i_L E_i \times 150\mu\text{s} = \frac{v_o^2}{R} \frac{1}{f_{\text{var}}}$$

that is

$$f_{\text{var}} = \frac{R_{\text{crit}}}{\tau} \frac{1}{R} = \frac{22\frac{1}{2}\Omega}{150\mu\text{s}} \frac{1}{R}$$

$$f_{\text{var}} = \frac{150}{R} \text{ kHz for } R \geq 22\frac{1}{2}\Omega$$

- The $\pm 5\text{A}$ inductor ripple current is independent of the load, provided the critical load resistance is not exceeded. When the average inductor current (input current) is less than 5A more than the output current, the capacitor must provide load current not only when the switch is on but also when the switch is off. The transition is given by equation (19.63), that is

$$\delta \leq 1 - \sqrt{\frac{2L}{\tau R}}$$

$$\frac{1}{3} \leq 1 - \sqrt{\frac{2 \times 250 \mu\text{H}}{150 \mu\text{s} \times R}}$$

This yields $R \geq 7\frac{1}{2}\Omega$ and a load current of 10A. The average inductor current is 15A, with a minimum value of 10A, the same as the load current. That is, for $R < 7\frac{1}{2}\Omega$ all the load requirement is provided from the input inductor when the switch is off, with excess energy charging (replenishing) the output capacitor. For $R > 7\frac{1}{2}\Omega$ insufficient energy is available from the inductor to provide the load energy throughout the whole of the period when the switch is off. The capacitor supplements the load requirement towards the end of the off period. When $R > 22\frac{1}{2}\Omega$ (the critical resistance), discontinuous inductor current occurs, and the duty cycle dependent transfer function is no longer valid.

Example 19.4: Alternative boost (step-up flyback) converter

The alternative boost converters (producing a dc supply either above E_i (left) or below 0V (right) – see figure 19.15b) shown in the following figure are to operate under the same conditions as the boost converter in example 19.3, namely, with a $50\mu\text{s}$ transistor fixed on-time in order to convert the 50V input up to 75V at the output. The energy transfer inductor is $250\mu\text{H}$ and the resistive load is 2.5Ω .

- Derive the voltage transfer ratio and critical resistance expression for the alternative boost converter, hence showing the control performance is identical to the boost converter shown in figure 19.7.
- By considering circuit voltage and current waveforms, identify how the two boost converters differ from the conventional boost circuit in figure 19.7. Use example 19.3 for a comparison basis.

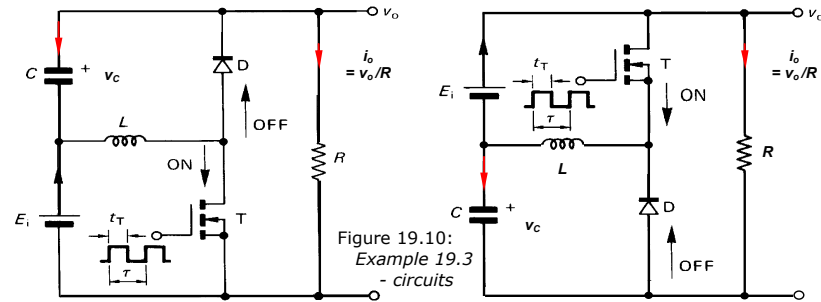

Figure 19.10:
Example 19.3
- circuits

Solution

- Assuming non-zero, continuous inductor current, the inductor current excursion, from $v = Ldi/dt$, which for this boost converter is not the input current excursion, during the switch on-time t_T and switch off-time $\tau - t_T$, is given by

$$L\Delta i_L = E_i t_T = v_c(\tau - t_T)$$

but $v_c = v_o - E_i$, thus substitution for v_c gives

$$E_i t_T = (v_o - E_i)(\tau - t_T)$$

and after rearranging

$$\frac{v_o}{E_i} = \frac{\bar{I}_L}{\bar{I}_o} = \frac{1}{1 - \delta} \quad \left(= 1 + \frac{\delta}{1 - \delta} : \text{that is } v_o \geq E_i \text{ alternately } E_i + \delta v_o = v_o \right)$$

where $\delta = t_T/\tau$ and t_T is the transistor on-time. This is the same voltage transfer function as for the conventional boost converter, equation (19.51). This result would be expected since both converters have the same ac equivalent circuit. Similarly, the critical resistance would be expected to be the same for each boost converter variation.

Examination of the switch on and off states shows that during the switch on-state, energy is transfer to the load from the input supply, independent of switching action. This mechanism is analogous to ac auto-transformer action where the output current is due to both transformer action and the input current being directed to the load.

The critical load resistance for continuous inductor current is specified by $R_{crit} \leq v_o / \bar{I}_o$.

By equating the capacitor net charge flow, the inductor current is related to the output current by $\bar{I}_L = \bar{I}_o / (1 - \delta)$. At minimum inductor current, $\bar{I}_L = \frac{1}{2}\Delta i_L$ and substituting with $\Delta i_L = E_i t_T / L$, gives

$$R_{crit} \leq \frac{v_o}{\bar{I}_o} = \frac{v_o}{(1 - \delta)\bar{I}_L} = \frac{v_o}{(1 - \delta)\frac{1}{2}\Delta i_L} = \frac{v_o}{(1 - \delta)\frac{1}{2}E_i t_T / L} = \frac{2L}{\tau\delta(1 - \delta)^2}$$

Thus for a given energy throughput, some energy is provided from the supply to the load when providing the inductor energy, hence the discontinuous inductor current threshold occurs at the same load level for each boost converter, including the basic converter in figure 19.7.

- Since the boost circuits have the same ac equivalent circuit, the inductor and capacitor, currents and voltages would be expected to be basically the same for each circuit, as shown by the waveforms in example 19.3. Consequently, the switch and diode voltages and currents are also the same for each boost converter. (Technically the switch on and off states are those of the buck-boost converter.) The two principal differences are the supply current and the capacitor voltage rating. The capacitor voltage rating for the alternative boost converter is lower, $v_o - E_i$, as opposed to v_o for the conventional converter. The supply current for the alternative converter is discontinuous (although always non-zero), as shown in the waveforms. This will negate the desirable continuous current feature exploited in boost converters that are controlled so as to produce sinusoidal input current or draw continuous input power. An isolated version, with the input supply isolated from the load, is not possible. But the couple inductor version shown in the example figure can be useful in avoiding very short (or long) switch duty cycles and help control (both avoiding or ensuring) continuous inductor current conduction conditions. Since the throughput energy is based on stored energy, the process is core volume dependant ($E = \frac{1}{2}BH \times \text{Volume}$).

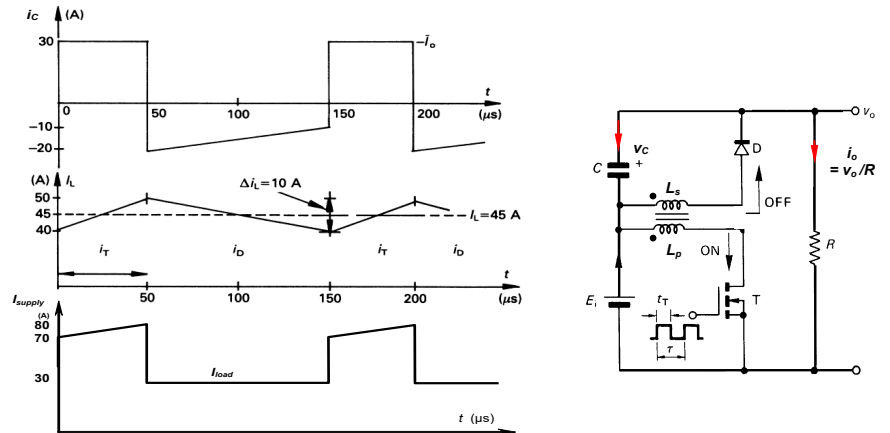

Figure 19.11: Example 19.3 – waveforms and coupled circuit version.

19.4 The buck-boost converter

The basic *buck-boost flyback converter* circuit is shown in figure 19.12a. When transistor T is on, energy is transferred to the inductor and the load current is provided solely from the output capacitor. When the transistor turns off, inductor current is forced through the diode. Energy stored in L is transferred to C and the load R. This transfer action results in an output voltage of opposite polarity to that of the input. Neither the input nor the output current is continuous, although the inductor current may be continuous or discontinuous.

19.4.1 Continuous choke (inductor) current (CCM - continuous conduction mode)

Various circuit voltage and current waveforms for the buck-boost flyback converter operating in a continuous inductor conduction mode (CCM) are shown in figure 19.12b.

Assuming a constant input and output voltage, from $v = Ldi/dt$, the change in inductor current is given by

$$\Delta i_L = \frac{E_i}{L} t_T = \frac{-v_o}{L} (\tau - t_T) \quad (19.81)$$

Thus assuming $P_{in} = P_{out}$, that is $v_o \bar{I}_o = E_i \bar{I}_i$

$$\frac{v_o}{E_i} = \frac{\bar{I}_i}{\bar{I}_o} = -\frac{\delta}{1-\delta} \quad (19.82)$$

where $\delta = t_r/\tau$. For $\delta < 1/2$ the output magnitude is less than the input voltage magnitude, while for $\delta > 1/2$ the output voltage is greater in magnitude (but as for $\delta < 1/2$, opposite in polarity) than the input voltage.

The maximum and minimum inductor current is given by

$$\hat{i}_L = \frac{\bar{I}_o}{1-\delta} + \frac{1}{2} \frac{v_o}{L} (1-\delta) \tau = v_o \left[\frac{1}{(1-\delta)R} + \frac{(1-\delta)\tau}{2L} \right] \quad (19.83)$$

and

$$\check{i}_L = \frac{\bar{I}_o}{1-\delta} - \frac{1}{2} \frac{v_o}{L} (1-\delta) \tau = v_o \left[\frac{1}{(1-\delta)R} - \frac{(1-\delta)\tau}{2L} \right] \quad (19.84)$$

The inductor rms ripple current is given by

$$i_{Lr} = \frac{\Delta i_L}{2\sqrt{3}} = \frac{1}{2\sqrt{3}} \frac{v_o}{L} (1-\delta) \delta \tau \quad (19.85)$$

while the inductor total rms current is

$$I_{Lrms} = \sqrt{\bar{I}_L^2 + i_{Lr}^2} = \sqrt{\bar{I}_L^2 + \left(\frac{1}{2} \frac{v_o}{L} (1-\delta) \delta \tau \right)^2} = \sqrt{\frac{1}{3} \left(\hat{i}_L^2 + \check{i}_L^2 + \bar{I}_L^2 \right)} \quad (19.86)$$

The switch and diode average and rms currents are given by

$$\bar{I}_T = \bar{I}_i = \delta \bar{I}_L \quad \bar{I}_D = (1-\delta) \bar{I}_L = \bar{I}_o \quad I_{Trms} = \sqrt{\delta} I_{Lrms} \quad I_{Drms} = \sqrt{1-\delta} I_{Lrms} \quad (19.87)$$

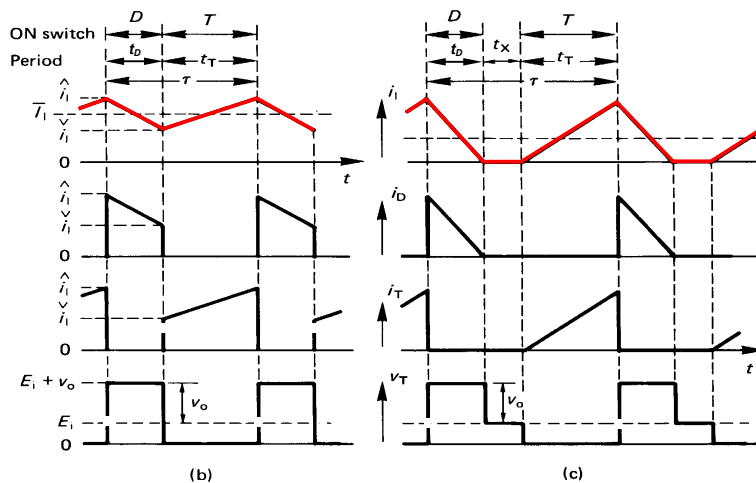
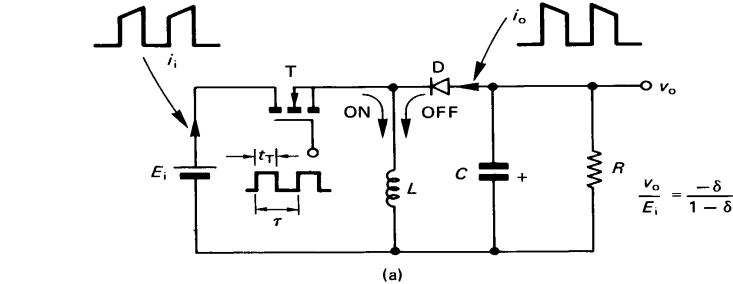

Figure 19.12. Non-isolated, step up/down flyback converter (buck-boost converter) where $v_o \leq 0$: (a) circuit diagram; (b) waveforms for continuous inductor current; and (c) discontinuous inductor current.

Switch and converter utilisation ratios

The switch utilisation ratio, SUR, is a measure of how fully a switching device's power handling capabilities are utilised in any switching application. The ratio is defined as

$$SUR = \frac{P_{out}}{p V_T I_T} \quad (19.88)$$

where p is the number of power switches in the circuit; $p=1$ for the buck-boost converter. The switch maximum instantaneous voltage and current are V_T and I_T , respectively. As shown in figure 19.12b, the maximum switch voltage supported in the off-state is $E_i + v_o$, while the maximum current is the maximum inductor current \hat{i}_L which is given by equation (19.83). If the inductance L is large such that the ripple current is small, the peak inductor current is approximated by the average inductor current which yields $I_T \approx \bar{I}_L = \bar{I}_o / (1-\delta)$, that is

$$SUR = \frac{v_o \bar{I}_o}{(E_i + v_o) \times \bar{I}_o / (1-\delta)} = \delta (1-\delta) \quad (19.89)$$

which assumes continuous inductor current. This result shows that the closer the output voltage v_o is in magnitude to the input voltage E_i , that is $\delta = 1/2$, the better the switch I - V ratings are utilised. The total converter semiconductor utilisation is represented by the factor U_f :

$$U_f = \frac{P_{rated}}{\sum_{VSI} V_{max} I_{rms}} = \frac{\delta \delta'}{\sqrt{\delta} + \sqrt{\delta'}} \quad (19.90)$$

19.4.2 Discontinuous capacitor charging current in the switch off-state

It is possible that the inductor current falls below the output (resistor) current during a part of the cycle when the switch is off and the inductor is transferring (replenishing) energy to the output circuit. Under such conditions, towards the end of the off period, some of the load current requirement is provided by the capacitor even though this is the period during which its charge is replenished by inductor energy. The circuit independent transfer function in equation (19.82) remains valid. This discontinuous capacitor charging condition occurs when the minimum inductor current and the output current are equal. That is

$$\begin{aligned} \check{i}_L - \bar{I}_o &\leq 0 \\ \bar{I}_L - \frac{1}{2} \Delta i_L - \bar{I}_o &\leq 0 \\ \frac{\bar{I}_o}{1-\delta} - \frac{1}{2} \frac{\bar{I}_o R}{L} (1-\delta) \tau - \bar{I}_o &\leq 0 \end{aligned} \quad (19.91)$$

which yields

$$\delta \leq 1 + \frac{L}{\tau R} - \sqrt{\left(1 + \frac{L}{\tau R}\right)^2 - 1} \quad (19.92)$$

19.4.3 Discontinuous choke current (DCM - discontinuous conduction mode)

The onset of discontinuous inductor operation occurs when the minimum inductor current \check{i}_L reaches zero. That is, with $\check{i}_L = 0$ in equation (19.84), the last equality

$$\frac{1}{(1-\delta)R} - \frac{(1-\delta)\tau}{2L} = 0 \quad (19.93)$$

relates circuit component values (R and L) and operating conditions (f and δ) at the verge of discontinuous inductor current.

The change from continuous to discontinuous inductor current conduction occurs when

$$\bar{I}_L = \frac{1}{2} \hat{i}_L = \frac{1}{2} \Delta i_L \quad (19.94)$$

where from equation (19.81) $\hat{i}_L = v_o(\tau - t_r) / L$

The circuit waveforms for discontinuous conduction are shown in figure 19.12c. The output voltage for discontinuous conduction is evaluated from

$$\hat{i}_L = \frac{E_i}{L} t = -\frac{v_o}{L} (\tau - t_r - t_x) \quad (19.95)$$

which yields

$$\frac{v_o}{E_i} = -\frac{\delta}{1-\delta - \frac{t_x}{\tau}} \quad (19.96)$$

Alternatively, using equation (19.95) and

$$\bar{I}_i = \frac{1}{2} \delta \hat{I}_L \quad (19.97)$$

yields

$$\bar{I}_i = \frac{E_i \tau \delta^2}{2L} \quad (19.98)$$

The inductor current is neither the input current nor the output current, but is comprised of separate displaced components (in time) of each of these currents. Examination of figure 19.12b, reveals that these currents are a proportion of the inductor current dependant on the duty cycle, and that on the verge of discontinuous conduction:

$$\bar{I}_i = \frac{1}{2} \delta \hat{I}_L \quad \text{and} \quad \bar{I}_o = \frac{1}{2} \delta_{off} \hat{I}_L = \frac{1}{2} (1 - \delta) \hat{I}_L \quad \text{where} \quad \hat{I}_L = \Delta I_L$$

Thus using power in equals power out, that is $E_i \bar{I}_i = V_o \bar{I}_o$, equation (19.98) becomes

$$\frac{V_o}{E_i} = \frac{E_i \tau \delta^2}{2L \bar{I}_o} = \frac{V_o \tau \delta^2}{2L \bar{I}_i} = \delta \sqrt{\frac{\tau R}{2L}} \quad (19.99)$$

On the verge of discontinuous conduction, these equations can be rearranged to give

$$\bar{I}_o = \frac{E_i}{2L} \tau \delta (1 - \delta) = \frac{V_o}{2L} \tau (1 - \delta)^2 \quad (19.100)$$

At a low output current or low input voltage there is a likelihood of discontinuous conduction. To avoid this condition, a larger inductance value is needed, which degrades the transient response. Alternatively, with extremely low on-state duty cycles, a voltage-matching transformer can be used to increase δ . Once a transformer is employed, any smps technique can be used to achieve the desired output voltage. Figures 19.12b and c show that both the input and output currents are always discontinuous.

19.4.4 Load conditions for discontinuous inductor current

As the load current decreases, the inductor average current also decreases, but the inductor ripple current magnitude is unchanged. If the load resistance is increased sufficiently, the bottom of the triangular inductor current, \hat{I}_L , eventually reduces to zero. Any further increase in load resistance causes discontinuous inductor current and the voltage transfer function given by equation (19.82) is no longer valid and equations (19.95) and (19.99) are applicable. The critical load resistance for continuous inductor current is specified by

$$R_{crit} \leq \frac{V_o}{\bar{I}_o} \quad (19.101)$$

Substituting for, the average input current in terms of \hat{I}_L and V_o in terms of ΔI_L from equation (19.81), yields

$$R_{crit} \leq \frac{V_o}{\bar{I}_o} = \frac{2L}{\tau (1 - \delta)^2} \quad (19.102)$$

By substituting the switching frequency ($f_s = 1 / \tau$) or the fundamental inductor reactance ($X_L = 2\pi f_s L$) the following critical resistance forms result.

$$R_{crit} \leq \frac{V_o}{\bar{I}_o} = \frac{2L}{\tau (1 - \delta)^2} = \frac{V_o}{E_i} \times \frac{2L}{\tau \delta (1 - \delta)} = \frac{2f_s L}{(1 - \delta)^2} = \frac{X_L}{\pi (1 - \delta)^2} \quad (\Omega) \quad (19.103)$$

Rearranged this equation gives L_{min} . Equation (19.103) is equation (19.93), re-arranged.

If the load resistance increases beyond R_{crit} , the output voltage can no longer be maintained with duty cycle control according to the voltage transfer function in equation (19.82).

19.4.5 Control methods for discontinuous inductor current

Once the load current has reduced to the critical level as specified by equation (19.103), the input energy is in excess of the load requirement. Open loop load voltage regulation control is lost and the capacitor C tends to overcharge.

Hardware approaches can solve this problem – by ensuring continuous inductor current

- increase L thereby decreasing the inductor current ripple p-p magnitude
- step-down transformer impedance matching to effectively reduce the apparent load impedance

Two control approaches to maintain output voltage regulation when $R > R_{crit}$ are

- vary the switching frequency f_s , maintaining the switch on-time t_T constant so that ΔI_L is fixed or
- reduce the switch on-time t_T , but maintain a constant switching frequency f_s , thereby reducing ΔI_L .

If a fixed switching frequency is desired for all modes of operation, then reduced on-time control, using output voltage feedback, is preferred. If a fixed on-time mode of control is used, then the output voltage is control by inversely varying the frequency with output voltage. Alternatively, output voltage feedback can be used.

19.4.5i - fixed on-time t_T , variable switching frequency f_{var}

The operating frequency f_{var} is varied while the switch-on time t_T is maintained constant such that the ripple current remains unchanged. Operation is specified by equating the input energy and the output energy, thus maintaining a constant capacitor charge, hence output voltage. That is, equating energies

$$\frac{1}{2} \Delta I_L E_i t_T = \frac{V_o^2}{R} \frac{1}{f_{var}} \quad (19.104)$$

Isolating the variable switching frequency f_{var} gives

$$f_{var} = \frac{V_o^2}{\frac{1}{2} \Delta I_L E_i t_T R} = f_s R_{crit} \times \frac{1}{R} \quad (19.105)$$

Load resistance R is not a directly or readily measurable parameter for feedback proposes. Alternatively, since $V_o = \bar{I}_o R$, substitution for R in equation (19.105) gives

$$f_{var} = f_s \frac{R_{crit}}{V_o} \times \bar{I}_o \quad (19.106)$$

$$f_{var} \propto \bar{I}_o$$

That is, for discontinuous inductor current, namely $\bar{I}_L < \frac{1}{2} \Delta I_L$ or $\bar{I}_o < V_o / R_{crit}$, if the switch on-state period t_T remains constant and f_{var} is either varied proportionally with load current or varied inversely with load resistance, then the required output voltage V_o will be maintained.

19.4.5ii - fixed switching frequency f_s , variable on-time t_{Tvar}

The operating frequency f_s remains fixed while the switch-on time t_{Tvar} is reduced such that the ripple current can be reduced. Operation is specified by equating the input energy and the output energy as in equation (19.104), thus maintaining a constant capacitor charge, hence voltage. That is

$$\frac{1}{2} \Delta I_L E_i t_{Tvar} = \frac{V_o^2}{R} \frac{1}{f_s} \quad (19.107)$$

Isolating the variable on-time t_{Tvar} gives

$$t_{Tvar} = \frac{V_o^2}{\frac{1}{2} \Delta I_L E_i f_s R}$$

Substituting ΔI_L from equation (19.81) gives

$$t_{Tvar} = t_T \sqrt{R_{crit}} \times \frac{1}{\sqrt{R}} \quad (19.108)$$

$$t_{Tvar} \propto \frac{1}{\sqrt{R}}$$

Again, load resistance R is not a directly or readily measurable parameter for feedback proposes and substitution of V_o / \bar{I}_o for R in equation (19.78) gives

$$t_{Tvar} = t_T \sqrt{\frac{R_{crit}}{V_o}} \times \sqrt{\bar{I}_o} \quad (19.109)$$

$$t_{Tvar} \propto \sqrt{\bar{I}_o}$$

That is, if the switching frequency f_s is fixed and switch on-time t_T is reduced proportionally to $\sqrt{\bar{I}_o}$ or inversely to \sqrt{R} , when discontinuous inductor current commences, namely $\bar{I}_L < \frac{1}{2} \Delta I_L$ or $\bar{I}_o < V_o / R_{crit}$, then the required output voltage magnitude V_o will be maintained.

Alternatively the output voltage is related to the duty cycle by $V_o = -\delta E_i \sqrt{R\tau / 2L}$. See table 19.2.

19.4.6 Output ripple voltage

The output ripple voltage is the capacitor ripple voltage. Ripple voltage for a capacitor is defined as

$$\Delta V_o = \frac{1}{C} \int i dt$$

Figure 19.12 shows that the constant output current \bar{I}_o is provided solely from the capacitor during the on period t_T when the switch conducting, thus

$$\Delta v_o = \frac{1}{C} \int i dt = \frac{1}{C} t_T \bar{I}_o$$

Substituting for $\bar{I}_o = v_o / R$ gives

$$\Delta v_o = \frac{1}{C} \int i dt = \frac{1}{C} t_T \bar{I}_o = \frac{1}{C} t_T \frac{v_o}{R}$$

Rearranging gives the percentage peak-to-peak voltage ripple in the output voltage

$$\frac{\Delta v_o}{v_o} = \frac{1}{RC} t_T = \frac{\delta \tau}{RC} \quad (19.110)$$

The capacitor equivalent series resistance and inductance can be account for, as with the forward converter, 19.1.5. When the switch conducts, the output current is constant and is provided solely from the capacitor. Thus no ESL voltage effects result during this constant capacitor current portion of the switching cycle.

19.4.7 Buck-boost, flyback converter design procedure

The output voltage of the buck-boost converter can be regulated by operating at a fixed frequency and varying the transistor on-time t_T . However, the output voltage diminishes while the transistor is on and increases when the transistor is off. This characteristic makes the converter difficult to control on a fixed frequency basis.

A simple approach to control the flyback regulator in the discontinuous mode is to fix the peak inductor current, which specifies a fixed diode conduction time, t_D . Frequency then varies directly with output current and transistor on-time varies inversely with input voltage.

With discontinuous inductor conduction, the worst-case condition exists when the input voltage is low while the output current is at a maximum. Then the frequency is a maximum and the dead time t_x is zero because the transistor turns on as soon as the diode stops conducting.

Given Worst case

$$\begin{array}{ll} E_i = E_{i(\min)} & t_x = 0 \\ V_o & f_{(\max)} \quad \Delta e_o \\ \bar{I}_o = \bar{I}_{o(\max)} & \end{array}$$

Assuming a fixed peak inductor current \hat{i}_l and output voltage v_o , the following equations are valid

$$E_{i(\min)} t_T = v_o t_D = \hat{i}_l \times L \quad (19.111)$$

$$\tau_{(\min)} = 1 / f_{(\max)} \quad (19.112)$$

Equation (19.111) yields

$$t_D = \frac{1}{f_{(\max)} \left(\frac{v_o}{E_{i(\min)}} + 1 \right)} \quad (19.113)$$

Where the diode conduction time t_D is constant since in equation (19.111), v_o , \hat{i}_l , and L are all constants. The average output capacitor current is given by

$$\bar{I}_o = \frac{1}{2} \hat{i}_l (1 - \delta)$$

and substituting equation (19.113) yields

$$\bar{I}_{o(\max)} = \frac{1}{2} \hat{i}_l \times f_{(\max)} \times \frac{1}{f_{(\max)} \left(\frac{v_o}{E_{i(\min)}} + 1 \right)}$$

therefore

$$\hat{i}_l = 2 \times \bar{I}_{o(\max)} \times \left(\frac{v_o}{E_{i(\min)}} + 1 \right)$$

and upon substitution into equation (19.111)

$$L = \frac{t_D v_o}{2 \bar{I}_{o(\max)} \left(\frac{v_o}{E_{i(\min)}} + 1 \right)} \quad (19.114)$$

The minimum capacitance is specified by the maximum allowable ripple voltage, that is

$$C = \frac{\Delta Q}{\Delta e_o} = \frac{\hat{i}_l t_D}{2 \Delta e_o}$$

that is

$$C = \frac{\bar{I}_{o(\max)} t_D}{\Delta e_o \left(\frac{v_o}{E_{i(\min)}} + 1 \right)} \quad (19.115)$$

For large output capacitance, the ripple voltage is dropped across the capacitor equivalent series resistance, which is given by

$$ESR_{(\max)} = \frac{\Delta e_o}{\hat{i}_l} \quad (19.116)$$

The frequency varies as a function of load current. Equation (19.112) gives

$$\frac{\bar{I}_o}{f} = \frac{1}{2} \hat{i}_l t_T = \frac{\bar{I}_{o(\max)}}{f_{(\max)}}$$

therefore

$$f = f_{(\max)} \times \frac{\bar{I}_o}{\bar{I}_{o(\max)}} \quad (19.117)$$

and

$$f_{(\min)} = f_{(\max)} \times \frac{\bar{I}_{o(\min)}}{\bar{I}_{o(\max)}} \quad (19.118)$$

Example 19.5: Buck-boost flyback converter

The 10kHz flyback converter in figure 19.12 is to operate from a 50V input and produces an inverted non-isolated 75V output. The inductor is 300μH and the resistive load is 2.5Ω.

- Calculate the duty cycle, hence transistor off-time, assuming continuous inductor current.
- Calculate the mean input and output current.
- Draw the inductor current, showing the minimum and maximum values.
- Calculate the capacitor rms ripple current and output p-p ripple voltage if $C = 10,000\mu\text{F}$.
- Determine
 - the critical load resistance.
 - the minimum inductance for continuous inductor conduction with 2.5Ω load.
- At what load resistance does the instantaneous inductor current fall below the output current?
- What is the output voltage if the load resistance is increased to four times the critical resistance?

Solution

- From equation (19.96), which assumes continuous inductor current

$$\frac{v_o}{E_i} = -\frac{\delta}{1 - \delta} \quad \text{where } \delta = t_T / \tau$$

that is

$$\frac{75\text{V}}{50\text{V}} = \frac{\delta}{1 - \delta} \quad \text{thus } \delta = \frac{3}{5}$$

That is, $\tau = 1 / f_s = 100 \mu\text{s}$ with a 60μs switch on-time.

- The mean output current \bar{I}_o is given by

$$\bar{I}_o = v_o / R = 75\text{V} / 2.5\Omega = 30\text{A}$$

From power transfer considerations

$$\bar{I}_i = v_o \bar{I}_o / E_i = 75\text{V} \times 30\text{A} / 50\text{V} = 45\text{A}$$

- The average inductor current can be derived from

$$\bar{I}_i = \delta \bar{I}_L \quad \text{or} \quad \bar{I}_o = (1 - \delta) \bar{I}_L$$

That is

$$\begin{aligned} \bar{I}_L &= \bar{I}_i / \delta = \bar{I}_o / (1 - \delta) \\ &= 45\text{A} / \frac{2}{5} = 30\text{A} / \frac{2}{5} = 75\text{A} \end{aligned}$$

From $v = L di/dt$, the ripple current $\Delta i_L = E_i t_T / L = 50\text{V} \times 60\mu\text{s} / 300 \mu\text{H} = 10 \text{A}$, that is

$$\hat{i}_L = \bar{I}_L + \frac{1}{2} \Delta i_L = 75\text{A} + \frac{1}{2} \times 10\text{A} = 80\text{A}$$

$$\check{i}_L = \bar{I}_L - \frac{1}{2} \Delta i_L = 75\text{A} - \frac{1}{2} \times 10\text{A} = 70\text{A}$$

Since $\check{i}_L = 70\text{A} \geq 0\text{A}$, the inductor current is continuous, thus the analysis in parts *i*, *ii*, and *iii*, is valid.

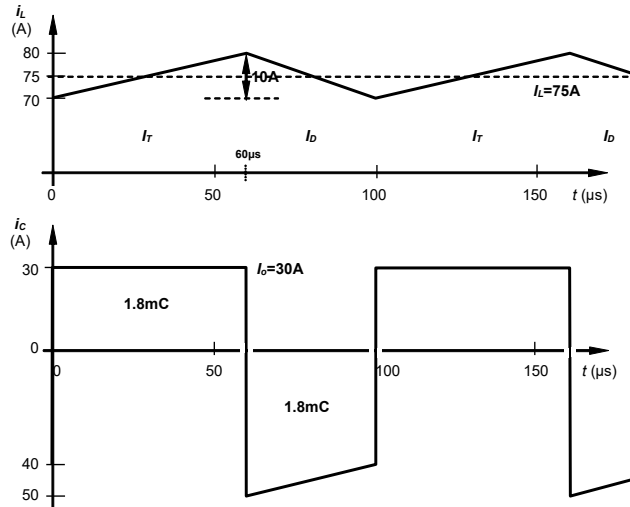

Figure 19.13: Example 19.4.

iv. The capacitor current is derived by using Kirchhoff's current law such that at any instant in time, the diode current, plus the capacitor current, plus the 30A constant load current into R , all sum to zero.

$$i_{C_{rms}} = \sqrt{\frac{1}{T} \left[\int_0^{t_r} \bar{I}_o^2 dt + \int_0^{t_r-t_f} \left(\frac{\Delta i_L}{t_r-t_f} t - \bar{i}_L + \bar{I}_o \right)^2 dt \right]}$$

$$= \sqrt{\frac{1}{100\mu s} \left[\int_0^{60\mu s} 30A^2 dt + \int_0^{40\mu s} \left(\frac{10A}{40\mu s} t - 50A \right)^2 dt \right]} = 36.8A$$

The output ripple voltage is given by equation (19.110), that is

$$\frac{\Delta V_o}{V_o} = \frac{\delta \tau}{CR} = \frac{\frac{3}{5} \times 100\mu s}{10,000\mu F \times 2\frac{1}{2}\Omega} \cong 0.24\%$$

The output ripple voltage is therefore

$$\Delta V_o = 0.24 \times 10^{-2} \times 75V = 180mV$$

v. The critical load resistance, R_{crit} , produces an inductor current with $\Delta i_L = 10A$ ripple. From equation (19.103)

$$R_{crit} = \frac{2L}{\tau(1-\delta)^2} = \frac{2 \times 300\mu H}{100\mu s \times (1-\frac{3}{5})^2} = 37\frac{1}{2}\Omega$$

The minimum inductance for continuous inductor current operation, with a $2\frac{1}{2}\Omega$ load, can be found by rearranging the critical resistance formula, as follows:

$$L_{crit} = \frac{1}{2} \tau R (1-\delta)^2 = \frac{1}{2} \times 2.5\Omega \times 100\mu s \times (1-\frac{3}{5})^2 = 20\mu H$$

vi. The $\pm 5A$ inductor ripple current is independent of the load, provided the critical resistance of $37\frac{1}{2}\Omega$ is not exceeded. When the average inductor current is less than 5A more than the output current, the capacitor must provide load current not only when the switch is on but also for a portion of the time when the switch is off. The transition is given by equation (19.92), that is

$$\delta \leq 1 + \frac{L}{\tau R} - \sqrt{\left(1 + \frac{L}{\tau R}\right)^2 - 1}$$

Alternately, when

$$\bar{I}_L - \bar{I}_o = 5A$$

$$\frac{\bar{I}_o}{1-\delta} - \bar{I}_o = 5A$$

For $\delta = \frac{3}{5}$, $\bar{I}_o = 3\frac{1}{3}A$. whence

$$R = \frac{V_o}{I_o} = \frac{75V}{\frac{10}{3}A} = 22\frac{1}{2}\Omega$$

The average inductor current is $8\frac{1}{3}A$, with a minimum value of $3\frac{1}{3}A$, the same as the load current. That is, for $R < 22\frac{1}{2}\Omega$ all the load requirement is provided from the inductor when the switch is off, with excess energy charging the output capacitor. For $R > 22\frac{1}{2}\Omega$ insufficient energy is available from the inductor to provide the load energy throughout the whole of the period when the switch is off. The capacitor supplements the load requirement towards the end of the off period. When $R > 37\frac{1}{2}\Omega$ (the critical resistance), discontinuous inductor current occurs, and the purely duty cycle dependent transfer function (circuit parameter independent) is no longer valid.

vii. When the load resistance is increased to 150Ω , four times the critical resistance, the output voltage is given by equation (19.99):

$$V_o = E_i \delta \sqrt{\frac{\tau R}{2L}} = 50V \times \frac{3}{5} \times \sqrt{\frac{100\mu s \times 150\Omega}{2 \times 300\mu H}} = 150V$$

19.5 Flyback converters – a conceptual assessment

In section 19.2, the boost and buck-boost converters were both introduced as flyback or ringing choke converters. This is not the traditional approach adopted to the classification of these two converters. This text has classified both as flyback converters since they are in fact the same converter. A converter is considered a two port network – an input E_i and an output v_o – that are related by a transfer function which (assuming continuous inductor current) is expressed in terms of the switch on-state duty cycle δ .

$$\frac{V_o}{E_i} = f(\delta)$$

A second output v_1 exists between the input E_i and the output v_o , as shown in figure 19.14. By Kirchhoff's voltage law, this auxiliary output is

$$v_1 = E_i - v_o$$

$$\frac{V_1}{E_i} = 1 - \frac{V_o}{E_i} = 1 - f(\delta)$$

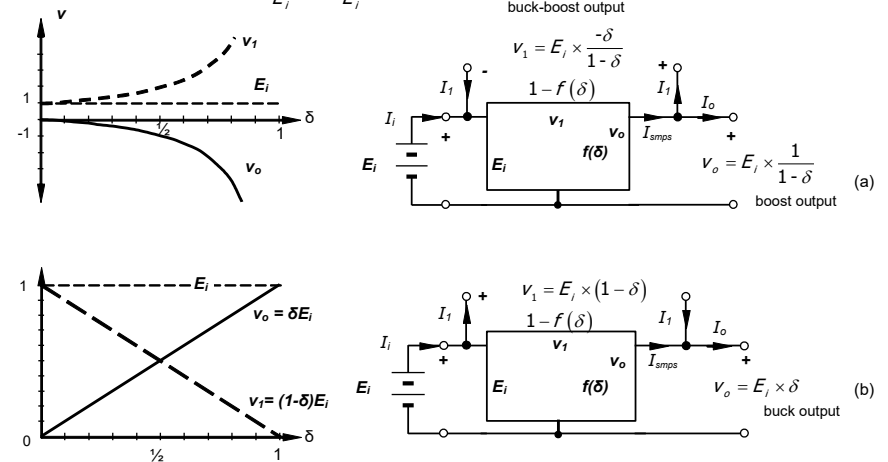

Figure 19.14. Basic converters shown as a three-port block diagrams for: (a) the flyback converter and (b) the forward converter.

The flyback converter – figure 19.14a

If $f(\delta)$ represents a boost converter, with a voltage transfer function $1/1-\delta$, then at the other port $1-f(\delta) = -\delta/1-\delta$, which is the buck-boost converter transfer function (assuming CCM). The converse is also true. Thus if a boost converter output exists, a buck-boost output is inherently available, independent of the connection position of the output capacitor C_o . In terms of dc circuit theory, the output capacitor can be

connected across v_o (as in figure 19.2), v_1 (as in example 19.3), or apportioned between both outputs. This concept is also the mechanism behind the converters in example 19.4. The circuit permutations in figure 19.15 show how the boost converter, using ac and dc circuit theory, can be systematically translated to the buck-boost converter, and vice versa. The schematic of an auto-transformer (variac) is interposed since it too can provide the equivalent two ac output possibilities. Whether a dc converter or an ac variac, power can be drawn from either output separately or from both outputs simultaneously. The output ports of both converters, when an extra switch and diode are added, are bidirectional reversible as considered in section 19.8.2, and operation is always CCM.

The forward converter – figure 19.14b

Just as the boost and buck-boost outputs are complementary, the buck converter has a complementary output possibility. If the output v_o is defined by the buck converter transfer function δ then the supplementary output v_1 is defined by $1 - \delta$. The output $1 - \delta$ cannot exist independently of the output δ (unless the converter is reversible – with an extra diode and switch, as in section 19.8.2). In order to maintain output voltage transfer function integrity according to the duty cycle dependant transfer functions, the current sourced from port v_o (the buck output) must exceed the current sunk by port v_1 . That is, if the outputs v_o and v_1 are resistively loaded, in figure 19.14a

$$I_{smpls} > 0$$

$$I_o \geq I_1$$

$$\frac{V_o}{R_o} \geq \frac{V_1}{R_1}$$

or

$$R_1 \geq R_o \frac{1 - \delta}{\delta}$$

Notice in figure 19.14a, in the flyback converter case, I_{smpls} is always positive. Therefore no load resistance restrictions exist for the two outputs, save the inductor current is continuous.

Thus only two fundamental single-switch, single-inductor converters (flyback and forward) exist, each offering two output voltage transfer function possibilities. One of the four output possibilities, $1 - \delta$, cannot uniquely exist, unless the converter is reversible (which involves two switches and two diodes).

Converter mechanism classification

The three traditional dc to dc converters can be classified according to the operational current paths of the inductor, and whether the input E_i and/or output v_o are involved during each switch state (ON or OFF). With reference to the states of the buck-boost converter in the following table, when the:

- switch is ON, the inductor current loop is as for the **boost** converter
- switch is OFF, the inductor current loop is as for the **buck** converter

converter	Switch State	
	ON current loop	OFF current loop
buck	$E_i - T - L - v_o$	$D - L - v_o$
boost	$E_i - L - T$	$E_i - L - D - v_o$
buck-boost	$E_i - T - L$	$D - L - v_o$

Technically, it is more meaningful if the so called buck-boost converter were termed boost-buck. More global examples of lack of technical correctness are the classification of the so called magnetic pole in the arctic region as the 'north pole' or having celebrated the millennium new-year's eve 1999/2000.

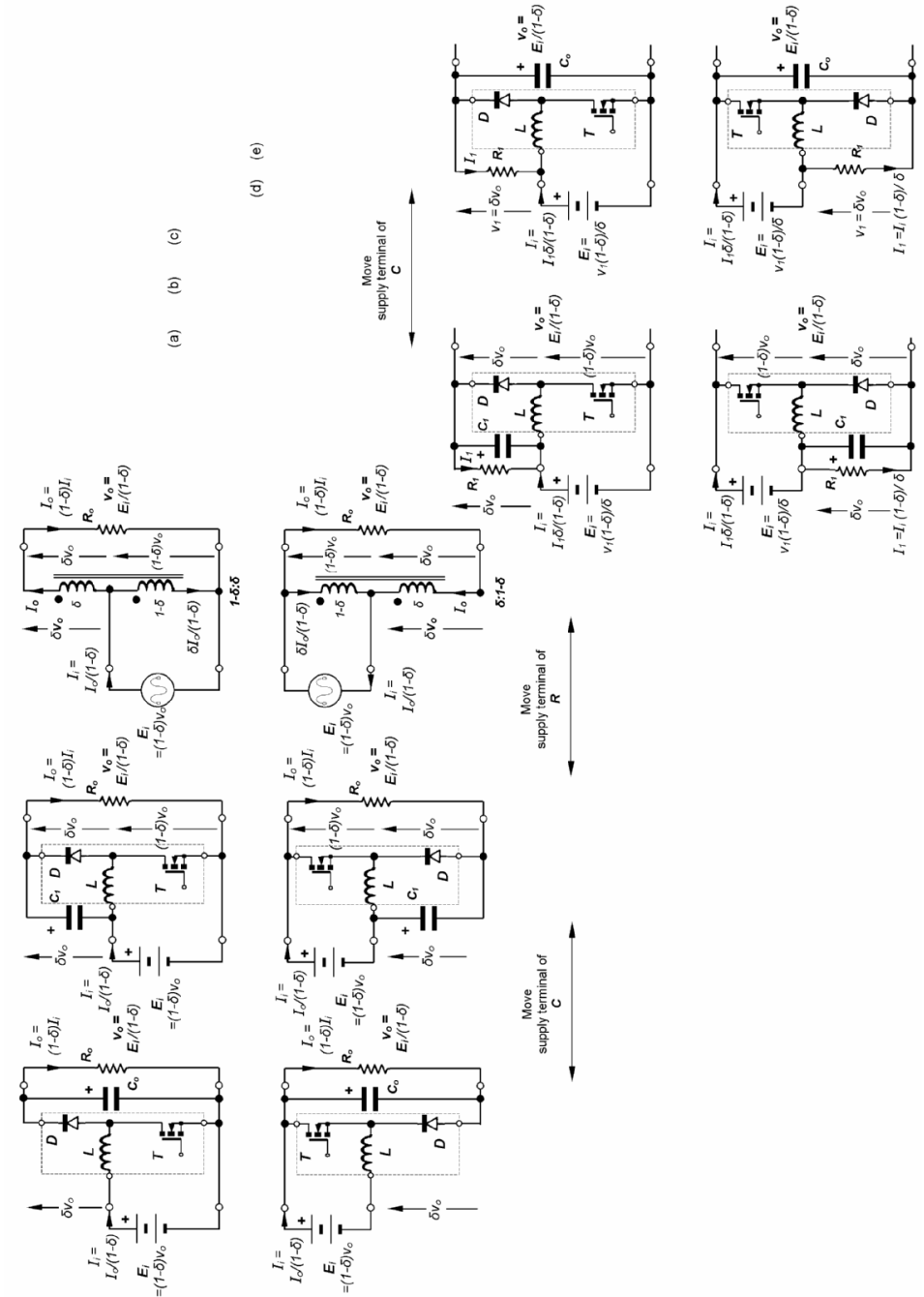

Figure 19.15. Basic: (a) boost to (e) buck-boost converter systematic translations (flipping).

19.6 The output reversible converter

The basic *reversible converter*, sometimes called an *asymmetrical half bridge converter* (see chapter 16.5), shown in figure 19.16a allows two-quadrant output voltage operation. Operation is characterised by both switches operating simultaneously, being either both on or both off.

The input voltage E_i is chopped by switches T_1 and T_2 , and because the input voltage is greater than the load voltage v_o , energy is transferred from the dc supply E_i to L , C , and the load R . When the switches are turned off, energy stored in L is transferred via the diodes D_1 and D_2 to C and the load R but in a path involving energy being returned to the supply, E_i . This connection feature allows energy to be transferred from the load back into E_i when used with an appropriate load and the correct duty cycle.

Parts b and c respectively of figure 19.16 illustrate reversible converter circuit current and voltage waveforms for continuous and discontinuous conduction of L , in a forward converter mode, when $\delta > 1/2$.

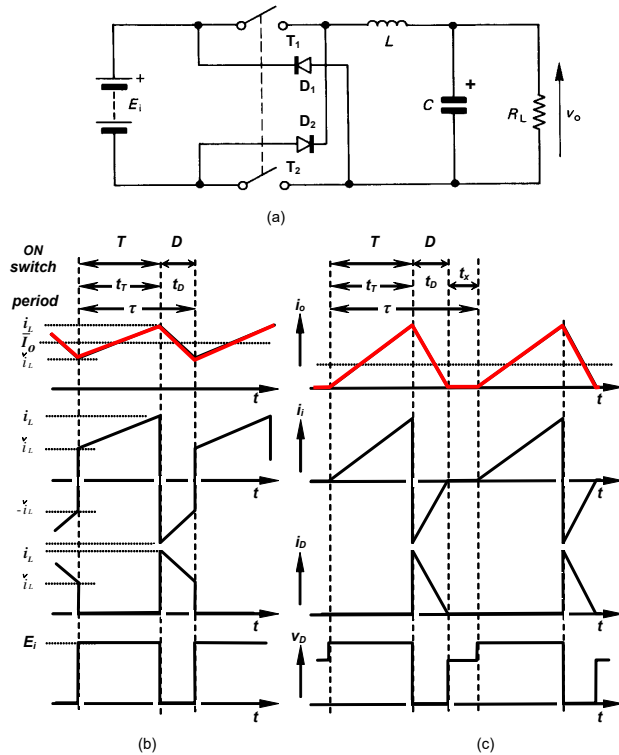

Figure 19.16. Basic reversible converter with $\delta > 1/2$: (a) circuit diagram; (b) waveforms for continuous inductor current; and (c) discontinuous inductor current.

For analysis it is assumed that components are lossless and the output voltage v_o is maintained constant because of the large capacitance magnitude of the capacitor C across the output. The input voltage E_i is also assumed constant, such that $E_i \geq v_o > 0$, as shown in figure 19.16a.

19.6.1 Continuous inductor current (CCM - continuous conduction mode)

When the switches are turned on for period t_r , the difference between the supply voltage E_i and the output voltage v_o is impressed across L . From $V = L di/dt$, the rising current change through the inductor will be

$$\Delta i_L = \hat{i}_L - \check{i}_L = \frac{E_i - v_o}{L} \times t_r \quad (19.119)$$

When the two switches are turned off for the remainder of the switching period, $\tau - t_r$, the two freewheel diodes conduct in series and $E_i + v_o$ is impressed across L . Thus, assuming continuous inductor conduction the inductor current fall is given by

$$\Delta i_L = \frac{E_i + v_o}{L} \times (\tau - t_r) \quad (19.120)$$

Equating equations (19.119) and (19.120) yields

$$\frac{v_o}{E_i} = \frac{\bar{I}_L}{\bar{I}_o} = \frac{2t_r - \tau}{\tau} = 2\delta - 1 \quad 0 \leq \delta \leq 1 \quad (19.121)$$

The voltage transfer function is independent of circuit inductance L and capacitance C .

Equation (19.121) shows that for a given input voltage, the output voltage is determined by the transistor conduction duty cycle δ and the output voltage $|v_o|$ is always less than the input voltage. This confirms and validates the original analysis assumption that $E_i \geq |v_o|$. The linear transfer function varies between -1 and 1 for $0 \leq \delta \leq 1$, that is, the output can be varied between $v_o = -E_i$ and $v_o = E_i$. The significance of the change in transfer function polarity at $\delta = 1/2$ is that

- for $\delta > 1/2$ the converter acts as a forward converter, but
- for $\delta < 1/2$, if the output is a negative source, the converter acts as a boost converter with energy transferred to the supply E_i from the negative output source.

Thus the transfer function can be expressed as follows

$$\frac{v_o}{E_i} = \frac{\bar{I}_L}{\bar{I}_o} = 2\delta - 1 = 2(\delta - 1/2) \quad 1/2 \leq \delta \leq 1 \quad (19.122)$$

and

$$\frac{E_i}{v_o} = \frac{\bar{I}_o}{\bar{I}_L} = \frac{1}{2\delta - 1} = \frac{1}{2(\delta - 1/2)} \quad 0 \leq \delta \leq 1/2 \quad (19.123)$$

where equation (19.123) is in the boost converter transfer function form.

19.6.2 Discontinuous inductor current (DCM - discontinuous conduction mode)

In the forward converter mode, $\delta \geq 1/2$, the onset of discontinuous inductor current operation occurs when the minimum inductor current \check{i}_L reaches zero. That is,

$$\bar{I}_L = 1/2 \Delta i_L = \bar{I}_o \quad (19.124)$$

If the transistor on-time t_r is reduced or the load resistance increases, the discontinuous condition dead time t_x appears as indicated in figure 19.16c. From equations (19.119) and (19.120), with $\check{i}_L = 0$, the following output voltage transfer function can be derived

$$\Delta i_L = \hat{i}_L - 0 = \frac{E_i - v_o}{L} \times t_r = \frac{E_i + v_o}{L} \times (\tau - t_r - t_x) \quad (19.125)$$

which after rearranging yields

$$\frac{v_o}{E_i} = \frac{2\delta - 1 - \frac{t_x}{\tau}}{1 - \frac{t_x}{\tau}} \quad 0 \leq \delta < 1 \quad (19.126)$$

19.6.3 Load conditions for discontinuous inductor current

In the forward converter mode, $\delta \geq 1/2$, as the load current decreases, the inductor average current also decreases, but the inductor ripple current magnitude is unchanged. If the load resistance is increased sufficiently, the trough of the triangular inductor current, \check{i}_L , eventually reduces to zero. Any further increase in load resistance causes discontinuous inductor current and the linear voltage transfer function given by equation (19.121) is no longer valid. Equation (19.126) is applicable. The critical load resistance for continuous inductor current is specified by

$$R_{crit} \leq \frac{V_o}{\bar{I}_o} \quad (19.127)$$

Substituting $\bar{I}_o = \bar{I}_L$ and using equations (19.119) and (19.124), yields

$$R_{crit} \leq \frac{V_o}{\bar{I}_o} = \frac{V_o}{1/2 \Delta i_L} = \frac{2V_o L}{(E_i - v_o)t_r} \quad (19.128)$$

Dividing throughout by E_i and substituting $\delta = t_r / \tau$ yields

$$R_{crit} \leq \frac{V_o}{\bar{I}_o} = \frac{(2\delta - 1)L}{(1 - \delta)\delta\tau} \quad (19.129)$$

By substituting the switching frequency ($f_s = 1/\tau$) or the fundamental inductor reactance ($X_L = 2\pi f_s L$), critical resistance can be expressed in the following forms.

$$R_{crit} \leq \frac{V_o}{\bar{I}_o} = \frac{2(\delta - \frac{1}{2})L}{(1 - \delta)\delta\tau} = \frac{2(\delta - \frac{1}{2})f_s L}{(1 - \delta)\delta} = \frac{(\delta - \frac{1}{2})X_L}{\pi(1 - \delta)\delta} \quad (\Omega) \quad (19.130)$$

If the load resistance increases beyond R_{crit} , the output voltage can no longer be maintained with duty cycle control according to the voltage transfer function in equation (19.121).

19.6.4 Control methods for discontinuous inductor current

Once the load current has reduced to the critical level as specified by equation (19.125) the input energy is in excess of the load requirement. Open loop load voltage regulation control is lost and the capacitor C tends to overcharge.

As with the other converters considered, hardware and control approaches can mitigate this overcharging problem. The specific control solutions for the forward converter in section 19.3.4, are applicable to the reversible converter. The two time domain control approaches offer the following operational modes.

19.6.4i - fixed on-time t_r , variable switching frequency f_{var}

The operating frequency f_{var} is varied while the switch-on time t_r is maintained constant such that the magnitude of the ripple current remains unchanged. Operation is specified by equating the input energy and the output energy, thus maintaining a constant capacitor charge, hence output voltage. That is, equating energies

$$\frac{1}{2}\Delta i_L E_i t_r = \frac{V_o^2}{R} \frac{1}{f_{var}} \quad (19.131)$$

Isolating the variable switching frequency f_{var} and using $V_o = \bar{I}_o R$ to eliminate R yields

$$f_{var} = f_s R_{crit} \times \frac{1}{R} = f_s \frac{R_{crit}}{V_o} \times \bar{I}_o \quad (19.132)$$

$$f_{var} \propto \frac{1}{R} \quad \text{or} \quad f_{var} \propto \bar{I}_o$$

That is, once discontinuous inductor current occurs at $\bar{I}_o < \frac{1}{2}\Delta i_L$ or $\bar{I}_o < V_o / R_{crit}$, a constant output voltage V_o can be maintained if the switch on-state period t_r remains constant and the switching frequency is varied

- proportionally with load current, \bar{I}_o
- inversely with the load resistance, R_{crit}
- inversely with the output voltage, V_o .

19.6.4ii - fixed switching frequency f_s , variable on-time t_{rvar}

The operating frequency f_s remains fixed while the switch-on time t_{rvar} is reduced, resulting in the ripple current magnitude being reduced. Equating input energy and output energy as in equation (19.28), thus maintaining a constant capacitor charge, hence voltage, gives

$$\frac{1}{2}\Delta i_L E_i t_{rvar} = \frac{V_o^2}{R} \frac{1}{f_s} \quad (19.133)$$

Isolating the variable on-time t_{rvar} , substituting for Δi_L , and using $V_o = \bar{I}_o R$ to eliminate R , gives

$$t_{rvar} = t_r \sqrt{\frac{R_{crit}}{R}} \times \frac{1}{\sqrt{R}} = t_r \sqrt{\frac{R_{crit}}{V_o}} \times \sqrt{\bar{I}_o} \quad (19.134)$$

$$t_{rvar} \propto \frac{1}{\sqrt{R}} \quad \text{or} \quad t_{rvar} \propto \sqrt{\bar{I}_o}$$

That is, once discontinuous inductor current commences, if the switching frequency f_s remains constant, regulation of the output voltage V_o can be maintained if the switch on-state period t_r is varied

- proportionally with the square root of the load current, $\sqrt{\bar{I}_o}$
- inversely with the square root of the load resistance, $\sqrt{R_{crit}}$
- inversely with the square root of the output voltage, $\sqrt{V_o}$.

Example 19.6: Reversible output, forward converter

The step-down reversible converter in figure 19.16a operates at a switching frequency of 10 kHz. The output voltage is to be fixed at 48 V dc across a 1 Ω resistive load. If the input voltage $E_i = 192$ V and the choke $L = 200\mu\text{H}$:

- calculate the switch T on-time duty cycle δ and switch on-time t_r
- calculate the average load current \bar{I}_o , hence average input current \bar{I}_i
- draw accurate waveforms for
 - the voltage across, and the current through L ; v_L and i_L
 - the capacitor current, i_c
 - the switch and diode voltage and current; v_T , v_D , i_T , i_D
- calculate
 - the maximum load resistance R_{crit} before discontinuous inductor current with $L=200\mu\text{H}$ and
 - the value to which the inductance L can be reduced before discontinuous inductor current, if the maximum load resistance is 1 Ω .

Solution

- The switch on-state duty cycle δ can be calculate from equation (19.121), that is

$$2\delta - 1 = \frac{V_o}{E_i} = \frac{48\text{V}}{192\text{V}} = \frac{1}{4} \Rightarrow \delta = \frac{5}{8}$$

Also, from equation (19.121), for a 10kHz switching frequency, the switching period τ is 100 μs and the transistor on-time t_r is given by

$$\delta = \frac{t_r}{\tau} = \frac{t_r}{100\mu\text{s}} = \frac{5}{8}$$

whence the transistor on-time is 62 $\frac{1}{2}\mu\text{s}$ and the diodes conduct for 37 $\frac{1}{2}\mu\text{s}$.

- The average load current is $\bar{I}_o = \frac{V_o}{R} = \frac{48\text{V}}{1\Omega} = 48\text{A} = \bar{I}_i$

From power-in equals power-out, the average input current is

$$\bar{I}_i = V_o \bar{I}_o / E_i = 48\text{V} \times 48\text{A} / 192\text{V} = 12\text{A}$$

- The average output current is the average inductor current, 48A. The ripple current is given by equation (19.121), that is

$$\Delta i_L = \hat{i}_L - \check{i}_L = \frac{E_i - V_o}{L} \times t_r$$

$$= \frac{192\text{V} - 48\text{V}}{200\mu\text{H}} \times 62.5\mu\text{s} = 45\text{A p-p}$$

- Critical load resistance is given by equation (19.130), namely

$$R_{crit} \leq \frac{V_o}{\bar{I}_o} = \frac{(2\delta - 1)L}{\tau\delta(1 - \delta)}$$

$$= \frac{(2 \times \frac{5}{8} - 1) \times 200\mu\text{H}}{100\mu\text{s} \times \frac{5}{8} \times (1 - \frac{5}{8})} = 32/15\Omega$$

$$= 2\frac{2}{15}\Omega \quad \text{when} \quad \bar{I}_o = \frac{1}{2}\Delta i_L = 22\frac{1}{2}\text{A}$$

Alternatively, the critical load current is 22 $\frac{1}{2}$ A ($\frac{1}{2}\Delta i_L$), thus the load resistance must not be greater than $V_o / \bar{I}_o = 48\text{V} / 22.5\text{A} = 32/15\Omega$, if the inductor current is to be continuous.

The critical resistance formula given in equation (19.130) is valid for finding critical inductance when inductance is made the subject of the equation, that is, rearranging equation (19.130) gives

$$L_{crit} = R \times (1 - \delta) \times \delta \times \tau / (2\delta - 1) \quad (\text{H})$$

$$= 1\Omega \times (1 - \frac{5}{8}) \times \frac{5}{8} \times 100\mu\text{s} / (2 \times \frac{5}{8} - 1)$$

$$= 93\frac{3}{4}\mu\text{H}$$

That is, the inductance can be decreased from 200 μH to 93 $\frac{3}{4}\mu\text{H}$ when the load is 1 Ω and continuous inductor current will flow.

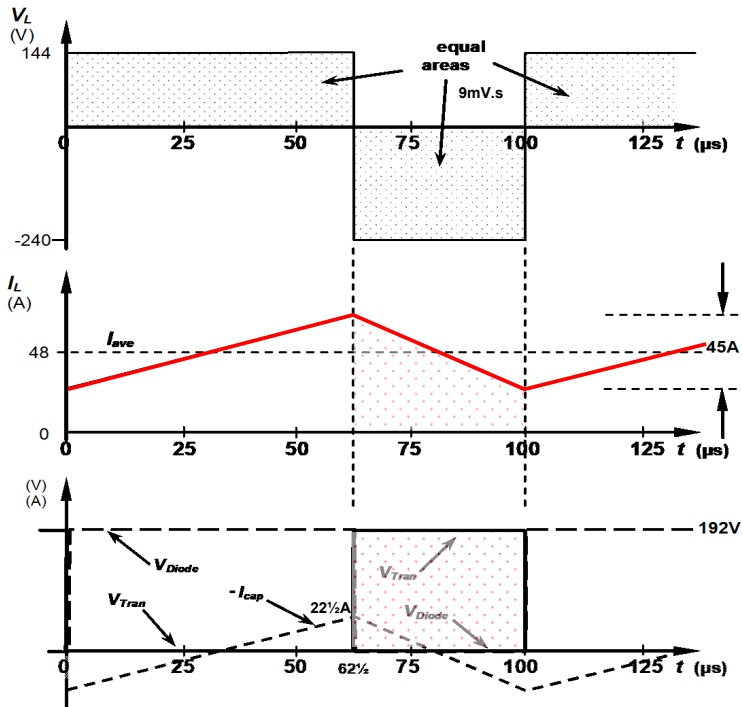

Figure 19.17: Example 19.5.

19.6.5 Comparison of the reversible converter with alternative converters

The reversible converter provides the full functional output range of the forward converter when $\delta > 1/2$ and provides part of the voltage function of the buck-boost converter when $\delta < 1/2$ but with energy transferring in the opposite direction.

Comparison of example 19.1 and 19.5 shows that although the same output voltage range can be achieved, the inductor ripple current is much larger for a given inductance L . A similar result occurs when compared with the buck-boost converter. Thus in each case, the reversible converter has a narrower output resistance range before discontinuous inductor conduction occurs. It is therefore concluded that the reversible converter should only be used if two-quadrant operation is needed.

The ripple current I_r given by equation (19.2) for the forward converter and equation (19.119) for the reversible converter when $v_o > 0$, yield the following current ripple relationship.

$$\bar{I}_r = (2 - 1/\delta_r) \times \bar{I}_r \quad (19.135)$$

where $2\delta_r - 1 = \delta_r$ for $0 \leq \delta_r \leq 1$ and $1/2 \leq \delta_r \leq 1$

This equation shows that the ripple current of the forward converter \bar{I}_r is never greater than the ripple current \bar{I}_r for the reversible converter, for the same output voltage.

In the voltage inverting mode, from equations (19.81) and (19.119), the relationship between the two corresponding ripple currents is given by

$$\bar{I}_{ry} = \frac{2(\delta_r - 1)}{2\delta_r - 1} \times \bar{I}_r \quad (19.136)$$

where $\frac{2(\delta_r - 1)}{2\delta_r - 1} = \delta_{ry}$ for $0 \leq \delta_{ry} \leq 1/2$ and $0 \leq \delta_r \leq 1/2$

Again the reversible converter always has the higher inductor ripple current. Essentially the higher ripple current results in each mode because the inductor energy release phase involving the diodes, occurs back into the supply, which is effectively in cumulative series with the output capacitor voltage.

The reversible converter offers some functional flexibility, since it can operate as a conventional forward converter, when only one of the two switches is turned off. (In fact, in this mode, switch turn-off is alternated between T_1 and T_2 so as to balance switch and diode losses.)

19.7 The boost-buck (Ćuk) converter

The boost-buck or Ćuk converter in figure 19.18 performs an inverting boost converter function with inductance in the input and the output. As a result, both the input and output currents can be continuous. Both the input inductor L_1 and the capacitor C_1 ac couple (transfer) energy from the input to the output. Both reactive elements produce the same buck-boost voltage transfer function. It is difficult to stabilise and L_1 and C_1 tend to resonant. An alternative to the generic origin of this topology is presented in 20.2.

19.7.1 Continuous inductor current (CCM - continuous conduction mode)

When the switch T is on and the diode D is reversed biased

$$i_{C1(on)} = -\bar{I}_{L2} = \bar{I}_o \quad (19.137)$$

When the switch is turned off, inductor currents i_{L1} and i_{L2} are diverted through the diode and

$$i_{C1(off)} = \bar{I}_i \quad (19.138)$$

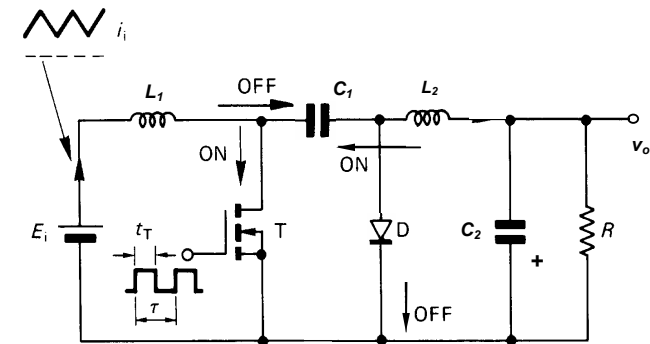

Figure 19.18. Basic Ćuk converter.

Over one steady-state cycle the average capacitor charge is zero, that is

$$i_{C1(on)}\delta\tau + i_{C1(off)}(1 - \delta)\tau = 0 \quad (19.139)$$

which gives

$$\frac{i_{C1(on)}}{i_{C1(off)}} = \frac{\delta}{1 - \delta} = \frac{\bar{I}_i}{\bar{I}_o} \quad (19.140)$$

From power-in equals power-out

$$\frac{v_o}{E_i} = \frac{\bar{I}_i}{\bar{I}_o} = \frac{\bar{I}_{L1}}{\bar{I}_{L2}} \quad (19.141)$$

Thus equation (19.140) becomes

$$\frac{v_o}{E_i} = \frac{\bar{I}_i}{\bar{I}_o} = \frac{\bar{I}_{L1}}{\bar{I}_{L2}} = -\frac{\delta}{1 - \delta} \quad (19.142)$$

19.7.2 Discontinuous inductor current (DCM - discontinuous conduction mode)

The current rise in L_1 occurs when the switch is on, that is

$$\Delta i_{L1} = \frac{\delta\tau E_i}{L_1} \quad (19.143)$$

For continuous current in the input inductor L_1 ,

$$\bar{I}_i = \bar{I}_{L1} \geq 1/2 \Delta i_{L1} \quad (19.144)$$

which yields a maximum allowable load resistance, for continuous inductor current, of

$$R_{crit} \leq \frac{v_o}{\bar{I}_o} = \frac{2\delta L_1}{\tau(1 - \delta)^2} = \frac{2f_s L_1 \delta}{(1 - \delta)^2} = \frac{\delta X_{L1}}{\pi(1 - \delta)^2} \quad (19.145)$$

This is the same expression as that obtained for the boost converter, equation (19.73), which can be re-arranged to give the minimum inductance for continuous input inductor current, namely

$$\check{L}_1 = \frac{(1-\delta)^2 R\tau}{2\delta} \quad (19.146)$$

The current rise in L_2 occurs when the switch is on and the inductor voltage is E_i , that is

$$\Delta i_{L2} = \frac{\delta\tau E_i}{L_2} \quad (19.147)$$

For continuous current in the output inductor L_2 ,

$$\bar{I}_o = \bar{I}_{L2} \geq \frac{1}{2}\Delta i_{L2} \quad (19.148)$$

which yields

$$R_{crit} \leq \frac{V_o}{\bar{I}_o} = \frac{2L_2}{\tau(1-\delta)} = \frac{2f_s L_2}{1-\delta} = \frac{X_{L2}}{\pi(1-\delta)} \quad (19.149)$$

This is the same expression as that obtained for the forward converter, equation (19.27) which can be re-arranged to give the minimum inductance for continuous output inductor current, namely

$$\check{L}_2 = \frac{1}{2}(1-\delta)R\tau \quad (19.150)$$

19.7.3 Optimal inductance relationship

Optimal inductor conditions are that both inductors should both simultaneously reach the verge of discontinuous conduction. The relationship between inductance and ripple current is given by equations (19.143) and (19.147).

$$\Delta i_{L1} = \frac{\delta\tau E_i}{L_1} \quad \text{and} \quad \Delta i_{L2} = \frac{\delta\tau E_i}{L_2}$$

After dividing these two equations

$$\frac{L_2}{L_1} = \frac{\Delta i_{L1}}{\Delta i_{L2}} \quad (19.151)$$

Critical inductance is given by equations (19.146) and (19.150), that is

$$\check{L}_2 = \frac{1}{2}(1-\delta)R\tau \quad \text{and} \quad \check{L}_1 = \frac{(1-\delta)^2 R\tau}{2\delta}$$

After dividing

$$\frac{\check{L}_2}{\check{L}_1} = \frac{\delta}{1-\delta} \quad (19.152)$$

At the verge of simultaneous discontinuous inductor conduction

$$\frac{\check{L}_2}{\check{L}_1} = \frac{\delta}{1-\delta} = \frac{\Delta i_{L1}}{\Delta i_{L2}} = \left| \frac{V_o}{E_i} \right| \quad (19.153)$$

That is, the voltage transfer ratio uniquely specifies the ratio of the minimum inductances and their ripple current.

19.7.4 Output voltage ripple

The output stage (L_2 , C_2 , and R) is the forward converter output stage; hence the per unit output voltage ripple on C_2 is given by equation (19.36), that is

$$\frac{\Delta V_{C2}}{V_o} = \frac{\Delta V_o}{V_o} = \frac{1}{8} \times \frac{(1-\delta)\tau^2}{L_2 C_2} \quad (19.154)$$

If the ripple current in L_1 is assumed constant, the per unit voltage ripple on the ac coupling capacitor C_1 is approximated by

$$\frac{\Delta V_{C1}}{V_o} = \frac{\delta\tau}{RC_1} \quad (19.155)$$

The capacitor C_1 should be large, such that it does not discharge during the switch on period.

The total converter semiconductor utilisation is represented by the factor U_f :

Converter utilisation ratio

The total converter semiconductor utilisation (for all buck-boost converters) is the factor U_f :

$$U_f = \frac{P_{rated}}{\sum_{VSI} V_{max} I_{rms}} = \frac{\delta'}{\sqrt{\delta} + \sqrt{\delta'}} \quad (19.156)$$

Example 19.7: Ćuk converter

The Ćuk converter in figure 19.18 is to operate at 10kHz from a 50V battery input and produces an inverted non-isolated 75V output. The load power is 1.8kW.

- Calculate the duty cycle hence switch on and off times, assuming continuous current in both inductors.
- Calculate the mean input and output, hence inductor, currents.
- At the 1.8kW load level, calculate the inductances L_1 and L_2 such that the ripple current is 1A p-p in each.
- Specify the capacitance for C_1 and C_2 if the ripple voltage is to be a maximum of 1% of the output voltage.
- Determine the critical load resistance for which the purely duty cycle dependant voltage transfer function becomes invalid.
- At the critical load resistance value, determine the inductance value to which the non-critically operating inductor can be reduced.
- Determine the necessary conditions to ensure that both inductors operate simultaneously on the verge of discontinuous conduction, and the relative ripple currents for that condition.

Solution

- The voltage transfer function is given by equation (19.142), that is

$$\frac{V_o}{E_i} = -\frac{\delta}{(1-\delta)} = -\frac{75V}{50V} = -1\frac{1}{2}$$

from which $\delta = \frac{3}{5}$. For a 10kHz switching frequency the period is 100 μ s, thus the switch on-time is 60 μ s and the off-time is 40 μ s.

- The mean output current is determined by the load and the mean input current is related to the output current by assuming 100% efficiency, that is

$$\bar{I}_o = \bar{I}_{L2} = P_o / V_o = 1800W / 75V = 24A$$

$$\bar{I}_i = \bar{I}_{L1} = P_o / E_i = 1800W / 50V = 36A$$

The load resistance is therefore $R = V_o / I_o = 75V / 24A = 3\frac{1}{8}\Omega$.

- The inductor ripple current for each inductor is given by the same expression, that is equations (19.143) and (19.147). Thus for the same ripple current of 1A pp

$$\Delta i_{L1} = \frac{\delta\tau E_i}{L_1} = \Delta i_{L2} = \frac{\delta\tau E_i}{L_2}$$

which gives

$$L_1 = L_2 = \frac{\delta\tau E_i}{\Delta i} = \frac{\frac{3}{5} \times 100\mu s \times 50V}{1A} = 3mH$$

- The capacitor ripple voltages are given by equations (19.155) and (19.154), which after re-arranging gives

$$C_1 = \frac{V_o}{\Delta V_{C1}} \times \frac{\delta\tau}{R} = \frac{100}{1} \times \frac{\frac{3}{5} \times 100\mu s}{2\frac{5}{8}\Omega} = 1.92mF$$

$$C_2 = \frac{V_o}{\Delta V_{C2}} \times \frac{1}{8} \times \frac{(1-\delta)\tau^2}{L_2} = \frac{100}{1} \times \frac{1}{8} \times \frac{(1-\frac{3}{5}) \times 100\mu s^2}{3mH} = 16.6\mu F$$

- The critical load resistance for each inductor is given by equations (19.145) and (19.149). When both inductors are 3mH:

$$R_{crit} \leq \frac{2\delta L_1}{\tau(1-\delta)^2} = \frac{2 \times \frac{3}{5} \times 3\text{mH}}{100\mu\text{s} \times (1 - \frac{3}{5})^2} = 225\Omega$$

$$R_{crit} \leq \frac{2L_2}{\tau(1-\delta)} = \frac{2 \times 3\text{mH}}{100\mu\text{s} \times (1 - \frac{3}{5})} = 150\Omega$$

The limiting critical load resistance is 150Ω or for $I_o = v_o/R = 75\text{V}/150\Omega = \frac{1}{2}\text{A}$, when a lower output current results in the current in L_2 becoming discontinuous although the current in L_1 is still continuous.

vi. From equation (19.145), rearranged

$$L_{1crit} \geq \frac{\tau R(1-\delta)^2}{2\delta} = \frac{100\mu\text{s} \times 100\Omega \times (1 - \frac{3}{5})^2}{2 \times \frac{3}{5}} = 2\text{mH}$$

That is, if L_1 is reduced from 3mH to 2mH, then both L_1 and L_2 enter discontinuous conduction at the same load condition, 75V, ½A, and 150Ω.

vii. For both converter inductors to be simultaneously on the verge of discontinuous conduction, equation (19.153) gives

$$\frac{L_2}{L_1} = \frac{\delta}{1-\delta} = \frac{\Delta I_{L1}}{\Delta I_{L2}} = \left| \frac{v_o}{E_i} \right|$$

$$\frac{3\text{mH}}{2\text{mH}} = \frac{\frac{3}{5}}{1 - \frac{3}{5}} = \frac{1\text{A}}{\frac{2}{5}\text{A}} = \left| \frac{75\text{V}}{50\text{V}} \right| = \frac{3}{2}$$

19.8 Comparison of basic converters

The converters considered employ an inductor to transfer energy from one dc voltage level to another dc voltage level. The basic converters comprise a switch, diode, inductor, and a capacitor. The reversible converter is a two-quadrant converter with two switches and two diodes, while the Ćuk converter uses two inductors and two capacitors.

Table 19.1 summarises the main electrical features and characteristics of each basic converter. Figure 19.19 shows a plot of the voltage transformation ratios and the switch utilisation ratios of the converters considered. With reference to figure 19.19, it should be noted that the flyback step-up/step-down converter and the Ćuk converter both invert the input polarity. Every converter can operate in any one of three inductor current modes:

- discontinuous
- continuous
- both continuous and discontinuous

The main converter operational features of continuous conduction compared with discontinuous inductor conduction are

- The voltage transformation ratio (transfer function) is independent of the load.
- Larger inductance but lower core hysteresis losses and saturation less likely.
- Higher converter costs with increased volume and weight.
- Worse transient response (L/R).
- Power delivered is inversely proportional to load resistance, $P = V_o^2 / R$. In the discontinuous conduction mode, power delivery is inversely dependent on inductance.

19.8.1 Critical load current (CCM – DCM boundary)

Examination of Table 19.1 shows no obvious commonality between the various converters and their performance factors and parameters. One common feature is the relationship between critical average output current \bar{I}_o and the input voltage E_i at the boundary of continuous and discontinuous conduction. Equations (19.15), (19.69), and (19.100) are identical, (for all smps), that is

$$\bar{I}_{o,critical} = \frac{E_i \tau}{2L} \delta(1-\delta) \tag{A} \tag{19.157}$$

Expressing the input voltage in terms of the output voltage and transfer function, leads to the critical load resistance, $V_o / \bar{I}_{o,critical}$. This quadratic expression in δ shows that the critical mean output current reduces to zero as the on-state duty cycle δ tends to zero or unity. The maximum critical load current condition, for a given input voltage E_i , is when $\delta = \frac{1}{2}$ and

$$\hat{I}_{o,c} = E_i \tau / 8L \tag{19.158}$$

Since power-in equals power-out, then from equation (19.157) the input average current and output voltage at the boundary of continuous conduction for all smps are related by

$$\bar{I}_{i,critical} = \frac{V_o \tau}{2L} \delta(1-\delta) \tag{A} \tag{19.159}$$

The maximum output current at the boundary (at $\delta = \frac{1}{2}$), for a given output voltage, v_o , is

$$\hat{I}_{i,c} = v_o \tau / 8L \tag{19.160}$$

The smps commonality factor reduces to $R_{crit} = \frac{V_o}{E_i} \times \frac{2L}{\tau \delta(1-\delta)}$.

The reversible converter, using the critical resistance equation (19.130) derived in section 19.6.3, yields twice the critical average output current given by equation (19.157). This is because its duty cycle range is restricted to half that of the other converters considered. Converter normalised equations for discontinuous conduction are shown in table 19.2. A detailed analysis summary of discontinuous inductor current operation is given in Appendix 20.5.

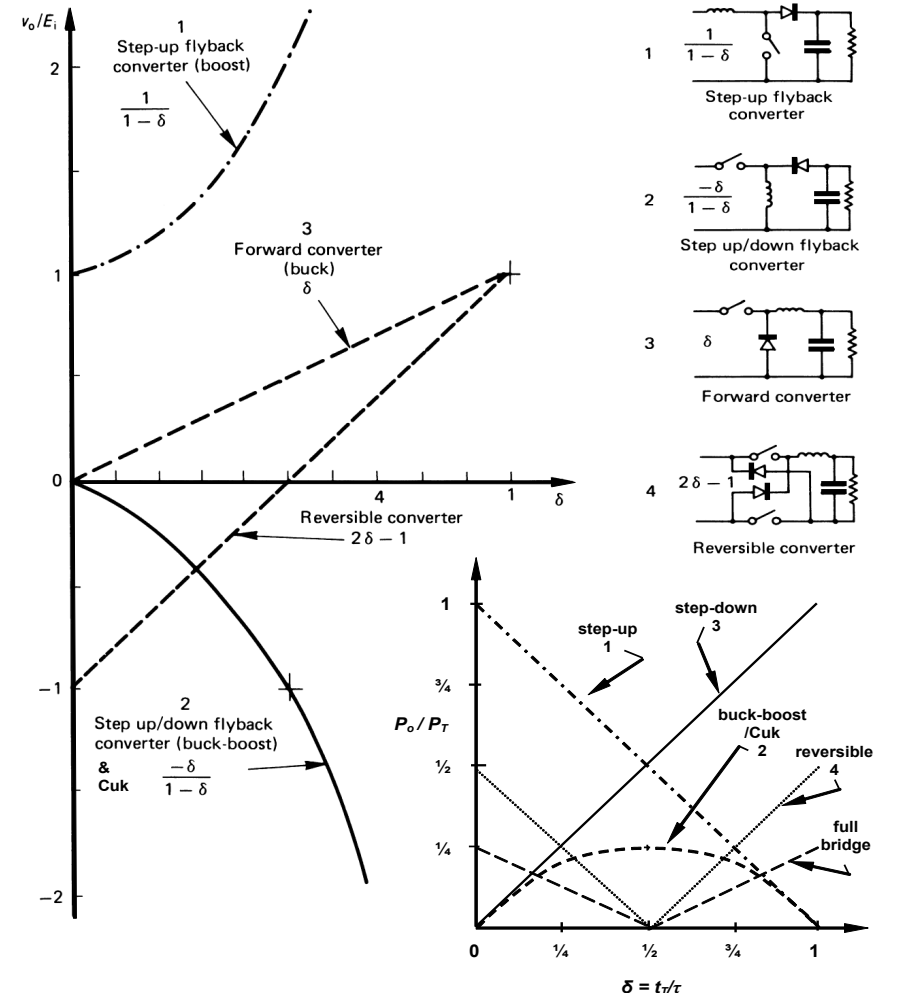

Figure 19.19. Transformation voltage ratios and switch utilisation ratios for five converters when operated in the continuous inductor conduction mode.

Table 19.1: Converter characteristics comparison with continuous inductor current

		converter			
		Forward Step-down	Flyback Step-up	Flyback Step-up/down	Reversible
Output voltage continuous I	v_o/E_i	δ	$\frac{1}{1-\delta}$	$-\frac{\delta}{1-\delta}$	$2\delta-1$
Output voltage discontinuous I	v_o/E_i	$1-\frac{2L\bar{I}_i}{E_i\delta^2\tau}$	$1+\frac{E_i\delta^2\bar{I}_i}{2L\bar{I}_o}$	$\frac{E_i\delta^2\tau}{2L\bar{I}_o}$	
Output polarity with respect to input		Non-inverted	Non-inverted	inverted	any
Current sampled from the supply		discontinuous	continuous	discontinuous	bi-directional
Load current		continuous	discontinuous	discontinuous	continuous
Maximum transistor voltage	V	E_i	v_o	E_i+v_o	E_i
Maximum diode voltage	V	E_i	v_o	E_i+v_o	E_i
Ripple current	Δi	$E_i\delta\tau(1-\delta)/L$	$E_i\delta\tau/L$	$E_i\delta\tau/L$	$2E_i\delta\tau(1-\delta)/L$
Maximum transistor current	\hat{I}_T	$\bar{I}_o + \frac{v_o\tau(1-\delta)}{2L}$	$\bar{I}_i + \frac{E_i\tau\delta}{2L}$	$\bar{I}_i + \frac{E_i\tau\delta}{2L}$	$\bar{I}_o + \frac{(E_i-v_o)\tau\delta}{2L}$
switch utilisation ratio	SUR	δ	$1-\delta$	$\delta(1-\delta)$	$\frac{1}{2}\delta$
Transistor rms current		low	high	high	low
Critical load resistance	R_{crit}	$\frac{2L}{\tau(1-\delta)}$	$\frac{2L}{\tau\delta(1-\delta)^2}$	$\frac{2L}{\tau(1-\delta)^2}$	$\frac{2(\delta-\frac{1}{2})L}{\tau\delta(1-\delta)}$
Critical inductance	L_{crit}	$\frac{1}{2}R\tau(1-\delta)$	$\frac{1}{2}R\tau\delta(1-\delta)^2$	$\frac{1}{2}R\tau(1-\delta)^2$	$\frac{1}{2}R\tau(1-\delta)\delta\tau(\delta-\frac{1}{2})$
o/p ripple voltage p-p	Δv_o	$\frac{\tau^2(1-\delta)}{8LC}v_o$	$\frac{\tau\delta}{RC}v_o$	$\frac{\tau\delta}{RC}v_o$	$\frac{\tau\delta}{RC}v_o$
Apparent load resistance	R_i	$R_o\frac{1}{\delta^2}$	$R_o(1-\delta)^2$	$R_o\left(\frac{1-\delta}{\delta}\right)^2$	$R_o\frac{1}{(2\delta-1)^2}$
Power P_{cont} $P_{discont}$	$P_{in}=P_{out}$	$V_oI_o - \frac{V_o^2}{R_{crit}}$ $\frac{t_r+t_D}{\tau}V_o^2\frac{\tau}{2L}$	$E_iI_i + \frac{V_o^2}{R_{crit}}$ $\frac{t_r+t_D}{\tau}E_i^2\frac{\tau}{2L}$	$\delta E_iI_i + \frac{V_o^2}{R_{crit}}$ $E_i^2\left(\frac{t_r}{\tau}\right)^2\frac{\tau}{2L}$	

Table 19.2: Comparison of characteristics when the inductor current is discontinuous, $\delta < \delta_{critical}$

$k = \frac{R\tau}{L}; \delta = \frac{t_r}{\tau}$	converter		
	Forward step-down	Flyback step-up	Flyback step-up/down
$\delta_{critical}(k) =$	$\delta \leq 1 - \frac{2}{k}$	$k > \frac{27}{2}$ then $\delta(1-\delta)^2 \leq \frac{2}{k}$	$\delta \leq 1 - \sqrt{\frac{2}{k}}$
$\frac{v_o}{E_i}(k, \delta) = \frac{\bar{I}_o R}{E_i}$	$\frac{1}{4}k\delta^2 \left[-1 + \sqrt{1 + \frac{8}{k\delta^2}} \right]$	$\frac{1}{2} \left[1 + \sqrt{1 + 2k\delta^2} \right]$	$-\delta\sqrt{\frac{2}{k}}$
$\delta_D = \frac{t_D}{\tau}(k, \delta)$	$\delta \times \left(1 - \frac{v_o}{E_i} \right) / \frac{v_o}{E_i}$	$\delta / \left(\frac{v_o}{E_i} - 1 \right)$	$\delta / \left \frac{v_o}{E_i} \right $
$\delta_x = \frac{t_x}{\tau}(k, \delta)$ $= 1 - \delta - \delta_D$	$1 - \delta / \frac{v_o}{E_i}$	$1 - \delta \times \frac{v_o}{E_i} / \frac{v_o}{E_i} - 1$	$1 - \delta \left(1 + \left \frac{v_o}{E_i} \right \right) / \left \frac{v_o}{E_i} \right $
$\hat{I}_L \times \frac{R}{E_i}(k, \delta)$	$k\delta \times \left[1 - \frac{v_o}{E_i} \right]$	$k\delta$	$k\delta$

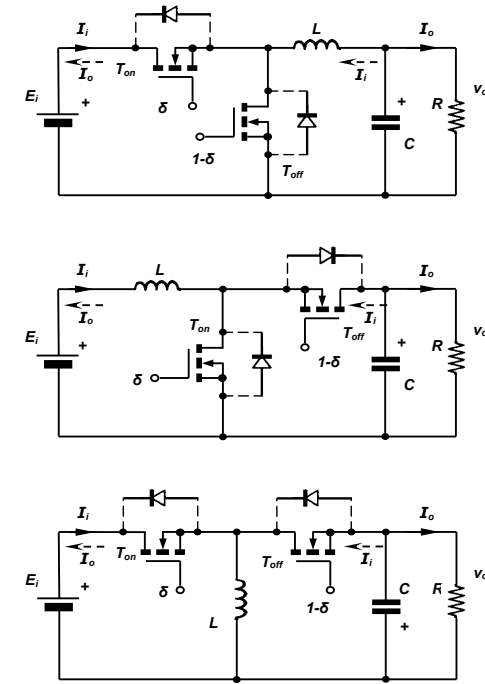

Figure 19.20. The three basic bidirectional current converter configurations: (a) the forward converter; (b) step-up flyback converter; and (c) step up/down flyback converter.

19.8.2 Bidirectional converters

Discontinuous inductor current, DCM, can be avoided if the smps diode is parallel connected with a shunt switch as shown in figure 19.20. If each switch has bipolar conduction properties, as with the MOSFET, then three functions can be performed

- **Synchronised rectification:** If the shunting switch conducts when the diode conducts, during period δ_D , then the diode is bypassed and losses are reduced to those of the MOSFET, which can be less than those of a Schottky diode. Reverse recovery can be circumvented.
- **Guaranteed continuous inductor current conduction:** If the shunting switch conducts for the period $1-\delta_D$ (complement to the main smps switch) then if the inductor current falls to zero, that current can reverse with energy taken from the output capacitor. Seamless, continuous inductor current results and importantly, the voltage transfer function is then that for continuous inductor current, independent of the load resistance.
- **Bidirectional energy transfer:** If the output diode has a shunting switch and an inverse parallel diode is added across the converter main switch (or both switches have bidirectional conduction properties, as with the MOSFET) then power can be efficiently and seamlessly transferred in either direction, between E_i and v_o . The voltage polarities are unchanged – it is the current direction that reverses. The buck and boost converters interchange transfer functions when operating in the reverse direction, while the buck/boost converter has the same transfer function in both current directions of operation.

19.8.3 Isolation

In each converter, the output is not electrically isolated from the input and a transformer can be used to provide isolation. Figure 19.21 shows isolated versions of the three basic converters. The transformer turns ratio provides electrical isolation as well as matching to obtain the required output voltage range.

- Figure 19.21a illustrates an isolated version of the forward converter shown in figure 19.2. When the transistor is turned on, diode D_1 conducts and L in the transformer secondary stores energy. When the transistor turns off, the diode D_3 provides a current path for the release of the energy stored in L . However when the transistor turns off and D_1 ceases to conduct, the stored transformer magnetising energy must be released. The winding incorporating D_2 provides a path to reset the core flux. A maximum possible duty cycle exists, depending on the turns ratio of the primary winding and freewheel winding. If a 1:1 ratio (as shown) is employed, a 50 per cent duty cycle limit will ensure the required volts-second for core reset.
- The step-up flyback isolated converter in part b of figure 19.21 is little used. The two transistors must be driven by complementary signals. Core leakage and reset functions (and no-load operation) are facilitated by a third winding and blocking diode D_2 .

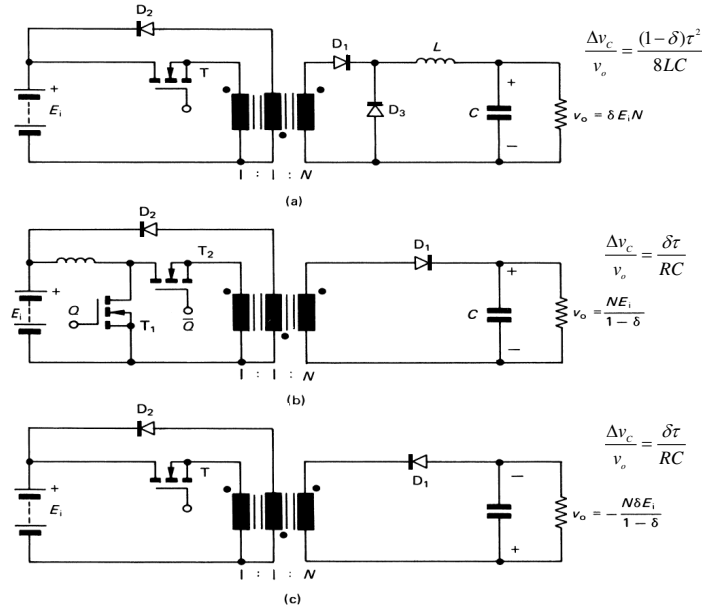

Figure 19.21. Isolated output versions of the three basic converter configurations: (a) the forward converter; (b) step-up flyback converter; and (c) step up/down flyback converter.

- The magnetic core in the buck-boost converter of part c of figure 19.21 performs a bifilar inductor function. When the transistor is turned on, energy is stored in the core. When the transistor is turned off, the core energy is released via the secondary winding into the capacitor. A core air gap is necessary to prevent magnetic saturation and an optional clamping winding can be employed, which operates at zero load.

The converters in parts a and c of figure 19.21 provide an opportunity to compare the main features and attributes of forward and flyback isolated converters. In the comparison it is assumed that the transformer turns ratio is 1:1:1.

19.8.3i - The isolated output, forward converter – figure 19.21a:

- $v_o = n_r E_i \delta$ or $I_i = n_r I_o \delta$
- The magnetic element acts as a transformer, that is, because of the relative voltage polarities of the windings, energy is transferred from the input to the output, and not stored in the core, when the switch is on. A small amount of magnetising energy, due to the magnetising current to flux the core, is built up in the core.
- The magnetising flux is reset by the current through the catch (feedback) winding and D_3 , when the switch is off. The magnetising energy is recovered and returned to the supply E_i .
- The necessary transformer $V\mu s$ balance requirement (core energy-in equals core energy-out) means the maximum duty cycle is limited to $0 \leq \delta \leq 1 / (1 + n_{fb}) < 1$ for $1:n_{fb}:n_{sec}$ turns ratio. For example, the duty cycle is limited to 50%, $0 \leq \delta \leq 1/2$, with a 1:1:1 turns ratio.

- Because of the demagnetising winding, the off-state switch supporting voltage is $E_i + v_o$.
- The blocking voltage requirement of diode D_3 is E_i , v_o for D_1 , and $2E_i$ for D_2 .
- The critical load resistance for continuous inductor current is independent of the transformer:

$$R_{crit} \leq \frac{4L}{\tau(1-2\delta)} \quad (19.161)$$

19.8.3ii - The isolated output, flyback converter – figure 19.21c:

- $v_o = n_r E_i \delta / (1 - \delta)$ or $I_i = n_r I_o \delta / (1 - \delta)$
- The magnetic element acts as a magnetic energy storage inductor. Because of the relative voltage polarities of the windings (dot convention), when the switch is on, energy is stored in the core and no current flows in the secondary.
- The stored energy, which is due to the core magnetising flux is released (reset) as current into the load and capacitor C when the switch is off. (Unlike the forward converter, where magnetising energy is returned to E_i , not the output, v_o .) Therefore there is no flyback converter duty cycle restriction, $0 \leq \delta \leq 1$.
- The third winding turns ratio is configured such that energy is only returned to the supply E_i under no load conditions.
- The switch supporting off-state voltage is $E_i + v_o$.
- The diode blocking voltage requirements are $E_i + v_o$ for D_1 and $2E_i$ for D_2 .
- The critical load resistance for continuous inductor current is independent of the transformer turns ratio when the magnetising inductance is referenced to the secondary:

$$R_{crit} \leq \frac{4L_{msec}}{\tau(1-2\delta)^2} = \frac{4n_r^2 L_{mprim}}{\tau(1-2\delta)^2} \quad (19.162)$$

The operational characteristics of each converter change considerably when the flexibility offered by tailoring the turns ratio is exploited. A multi-winding magnetic element design procedure is outlined in section 10.1.1, where the transformer turns ratio ($n_p:n_s$) is not necessarily 1:1:1.

The basic approach to any transformer (coupled circuit) problem is to transfer, or refer, all components and variables to either the transformer primary or secondary circuit, whilst maintaining power and time invariance. Thus, maintaining power-in equals power-out, and assuming a secondary to primary turns ratio of n_r is to one ($n_r:1$), gives

$$\frac{v_s}{v_p} = \frac{n_s}{n_p} = n_r, \quad \frac{i_p}{i_s} = \frac{n_s}{n_p} = n_r, \quad \frac{Z_s}{Z_p} = \left(\frac{n_s}{n_p}\right)^2 = n_r^2 \quad (19.163)$$

Time, that is switching frequency, power, and per unit values (δ , $\Delta v_o/v_o$), are invariant. The circuit is then analysed without a transformer. Subsequently, the appropriate parameters are referred back to their original side of the magnetically coupled circuit.

If the coupled circuit is used as a transformer, magnetising current (flux) builds, which must be reset to zero each cycle. Consider the transformer coupled forward converter in figure 19.21a. From Faraday's equation, $v = N d\phi / dt$, and for maximum on-time duty cycle δ the conduction $V\mu s$ of the primary must equal the conduction $V\mu s$ of the feedback winding which is returning the magnetising energy to the supply E_i .

$$E_i t_{on} = \frac{E_i}{n_{fb}} t_{off} \quad \text{and} \quad t_{on} + t_{off} = \tau \quad (19.164)$$

That is

$$E_i \hat{\delta} = \frac{E_i}{n_{fb}} (1 - \hat{\delta})$$

$$\hat{\delta} = \frac{1}{1 + n_{fb}} \quad (19.165)$$

$$0 \leq \delta \leq \frac{1}{1 + n_{fb}}$$

From Faraday's Law, the magnetizing current starts from zero and increases linearly to

$$\hat{I}_M = E_i t_{on} / L_M \quad (19.166)$$

where L_M is the magnetizing inductance referred to the primary. During the switch off period, this current falls linearly, as energy is returned to E_i . The current must reach zero before the switch is turned on again, whence the energy taken from E_i and stored as magnetic fluxing energy in the core, has been returned to the supply.

Two examples illustrate the features of magnetically coupled circuit converters. Example 19.8 illustrates how the coupled circuit in the flyback converter acts as an inductor, storing energy from the primary source, and subsequently releasing that energy in the secondary circuit. In example 19.9, the forward converter coupled circuit acts as a transformer where energy is transferred through the core under transformer action, but in so doing, self-inductance (magnetising) energy is built up in the core, which must be periodically released if saturation is to be avoided. Relative orientation of the windings, according to the flux dot convention shown in figure 19.21, is thus important, not only the primary relative to the secondary, but also relative to the feedback winding.

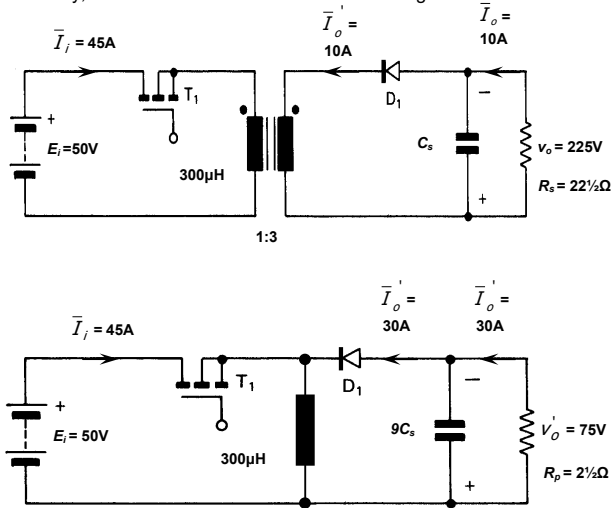

Figure 19.22. Isolated output step up/down flyback converter and its equivalent circuit when the secondary output is referred to the primary.

Example 19.8: Transformer coupled flyback converter

The 10kHz flyback converter in figure 19.21c operates from a 50V input and produces a 225V dc output from a 1:1.3 ($1:n_p/n_{sec}$) step-up transformer loaded with a $22\frac{1}{2}\Omega$ resistor. The transformer magnetising inductance is $300\mu\text{H}$, referred to the primary (or $300\mu\text{H}\times 3^2 = 2.7\text{mH}$ referred to the secondary):

- i. Calculate the switch duty cycle, hence transistor off-time, assuming continuous inductor current.
- ii. Calculate the mean input and output current.
- iii. Draw the transformer currents, showing the minimum and maximum values.
- iv. Calculate the capacitor rms ripple current and p-p voltage ripple if $C = 1100\mu\text{F}$.
- v. Determine
 - the critical load resistance
 - the minimum inductance for continuous inductor conduction for a $22\frac{1}{2}\Omega$ load.

Solution

The feedback winding does not conduct during normal continuous inductor current operation. This winding can therefore be ignored for analysis during normal operation.

Figure 19.22 shows secondary parameters referred to the primary, specifically

$$v_o = 225\text{V} \quad v_o' = v_o / n_T = 225\text{V}/3 = 75\text{V}$$

$$R_s = 22.5\Omega \quad R_p = R_s / n_T^2 = 22.5\Omega / 3^2 = 2.25\Omega$$

Note that the output capacitance is transferred by a factor of nine, n_T^2 , since capacitive reactance is inversely proportion to capacitance ($X = 1/\omega C$).

It will be noticed that the equivalent circuit parameter values to be analysed, when referred to the primary, are the same as in example 19.5. The circuit is analysed as in example 19.5 and the essential results from example 19.5 are summarised in Table 19.3 and transferred to the secondary where appropriate. The waveform answers to part iii are shown in figure 19.23.

Table 19.3: Transformer coupled flyback converter analysis

parameter		value for primary analysis	transfer factor $n_T = 3 \rightarrow$	value for secondary analysis
E_i	V	50	3	150
V_o	V	75	3	225
R_L	Ω	$2\frac{1}{2}$	3^2	$22\frac{1}{2}$
C_o	μF	10,000	3^{-2}	1100
L_M	μH	300	3^{-2}	2700
$I_{o(ave)}$	A	30	$\frac{1}{3}$	10
P_o	W	2250	invariant	2250
$I_{i(ave)}$	A	45	$\frac{1}{3}$	15
δ	p.u.	$3/5$	invariant	$3/5$
τ	μs	100	invariant	100
t_{on}	μs	60	invariant	60
t_D	μs	40	invariant	40
f_s	kHz	10	invariant	10
Δi_L	A	10	$\frac{1}{3}$	$10/3$
\bar{I}_L	A	75	$\frac{1}{3}$	25
\hat{I}_L	A	80	$\frac{1}{3}$	$80/3$
\bar{I}'_L	A	70	$\frac{1}{3}$	$70/3$
i_{Crms}	A rms	36.8	$\frac{1}{3}$	13.3
R_{crit}	Ω	$37\frac{1}{2}$	3^2	$337\frac{1}{2}$
L_{crit}	μH	20	3^2	180
V_{Dr}	V	125	3	375
Δv_o	mV	180	3	540
$\Delta v_o / V_o$	p.u.	0.24%	invariant	0.24%

Note the invariance of power, P_o ; normalised parameters δ , and $\Delta v_o / V_o$; and time t_{on} , t_D , τ , and $1/f$.

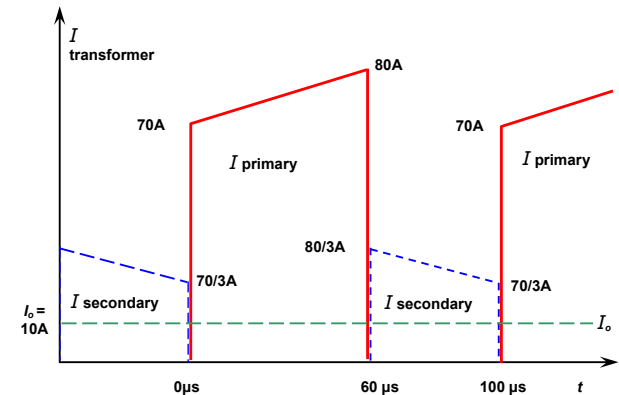

Figure 19.23. Currents for the transformer windings in example 19.8.

Example 19.9: Transformer coupled forward converter

The 10kHz forward converter in figure 19.21a operates from a 192V dc input and a 1:3:2 (1:n_{fb}:n_{sec}) step-up transformer loaded with a 4Ω resistor. The transformer magnetising inductance is 1.2mH, referred to the primary. The secondary smps inductance is 800μH.

- i. Calculate the maximum switch duty cycle, hence transistor off-time, assuming continuous inductor current.
- At the maximum duty cycle:
- ii. Calculate the mean input and output current.
- iii. Draw the transformer currents, showing the minimum and maximum values.
- iv. Determine
 - the critical load resistance
 - the minimum inductance for continuous inductor conduction for a 4 Ω load

Solution

i. The maximum duty cycle is determined solely by the transformer turns ratio between the primary and the feedback winding which resets the core flux. From equation (19.165)

$$\hat{\delta} = \frac{1}{1 + n_{f/b}} = \frac{1}{1 + 3} = 1/4$$

The maximum conduction time is 25% of the 100μs period, namely 25μs. The secondary output voltage is therefore

$$V_{sec} = \delta n_T E_i = 1/4 \times 2 \times 192 = 96V$$

The load current is therefore 96V/4Ω = 24A, as shown in figure 19.24a.

Figure 19.24b shows secondary parameters referred to the primary, specifically

$$R_s = 4\Omega \quad R_p = R_s / n_T^2 = 4\Omega / 2^2 = 1\Omega$$

$$V_o = 96V \quad V_o' = V_o / n_T = 96V/2 = 48V$$

$$L_o = 800\mu H \quad L_o' = L_o / n_T^2 = 800\mu H/2^2 = 200\mu H$$

Note that the output capacitance is transferred by a factor of four, n_T², since capacitive reactance is inversely proportion to capacitance, X = 1/ωC.

Inspection of example 19.1 will show that the equivalent circuit in figure 19.24b is the same as the circuit in example 19.1, except that a magnetising branch has been added. The various operating conditions and values in example 19.1 are valid for example 19.9.

ii. The mean output current is the same for both circuits (example 19.1), 48A, or 24 A when referred to the secondary circuit. The mean input current from E_i remains 12A, but the switch mean current is not 12A. Magnetising current is provided from the supply E_i through the switch, but returned to the supply E_i through diode D₂, which bypasses the switch. The net magnetising energy flow is zero. The magnetising current maximum value is given by equation (19.166)

$$\hat{I}_M = E_i t_{on} / L_M = 192V \times 25\mu s / 1.2mH = 4A$$

This current increases the switch mean current from 12A to

$$\bar{I}_T = 12A + 1/2 \times \delta \times 4A = 12 1/2 A$$

Figure 19.24c show the equivalent circuit when the switch is off. The output circuit functions independently of the input circuit, which is returning stored core energy to the supply E_i via the feedback winding and diode D₂. Parameters have been referred to the feedback winding which has three times the turns of the primary, n_{fb}=3. The 192V input voltage remains the circuit reference. Equation (19.166), Faraday's law, referred to the feedback winding, must be satisfied during the switch off period, that is

$$\frac{\hat{I}_M}{n_{f/b}} = \frac{E_i t_{off}}{n_{f/b}^2 L_M} \Rightarrow \frac{4}{3} = \frac{192V \times 75\mu s}{3^2 \times 1.2mH}$$

The diode D₂ voltage rating is (n_{fb}+1)×E_i, 768V and its mean current is

$$\bar{I}_{D2} = 1/2(1 - \delta) \frac{I_M}{n_{f/b}} = 1/2 \times (1 - 0.25) \times \frac{4A}{3} = 1/2 A$$

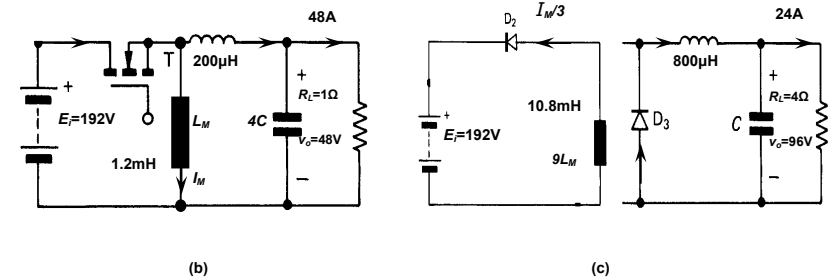
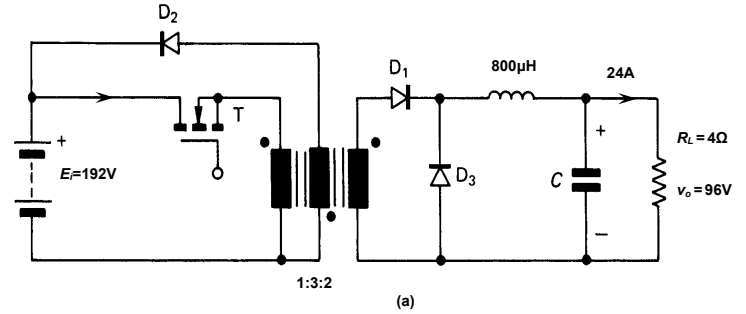

Figure 19.24. Isolated output forward converter and its equivalent circuits when the output is referred to the primary.

iii. The three winding currents for the transformer are shown in figure 19.25.

iv. The critical resistance and inductance, referred to the primary, from example 19.1 are 5 1/3Ω and 37 1/2μH. Transforming into secondary quantities, by multiplying by 2², give critical values of R_L = 21 1/3Ω and L = 150μH.

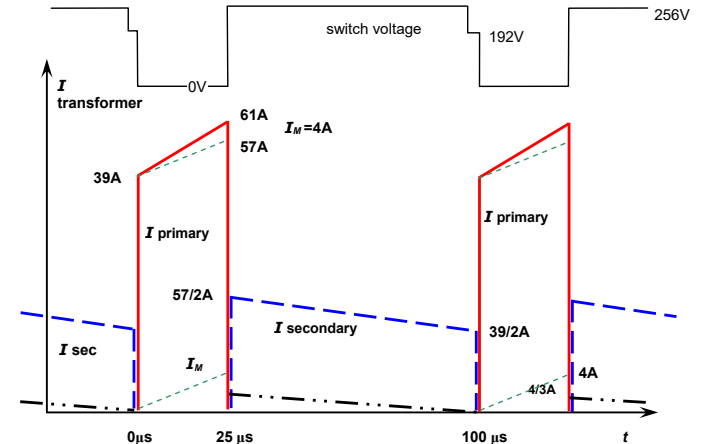

Figure 19.25. Currents for the three transformer windings in example 19.9.

19.9 Multiple-switch, balanced, isolated converters

The basic single-switch converters considered have the limitation of using their magnetic components (whether as an inductor or transformer) only in a unipolar flux mode. Since only one quadrant of the B - H characteristic is employed, these converters are generally restricted to lower powers because of the limited flux swing, which is reduced by the core remanence flux.

The high-power forward converter circuits shown in figure 19.26 operate the magnetic transformer component in the bipolar or push-pull flux mode and require two or four switches. Because the transformers are fully utilised magnetically, they tend to be almost half the size of the equivalent single transistor isolated converter at power levels above 100 W. Also core saturation due to the magnetising current (flux) not being fully reset to zero each cycle, is not a major issue, since with balanced bidirectional fluxing, the average magnetising current (flux) is zero. In each case, the transformer can be simplified to an auto-transformer, if isolation is not a requirement.

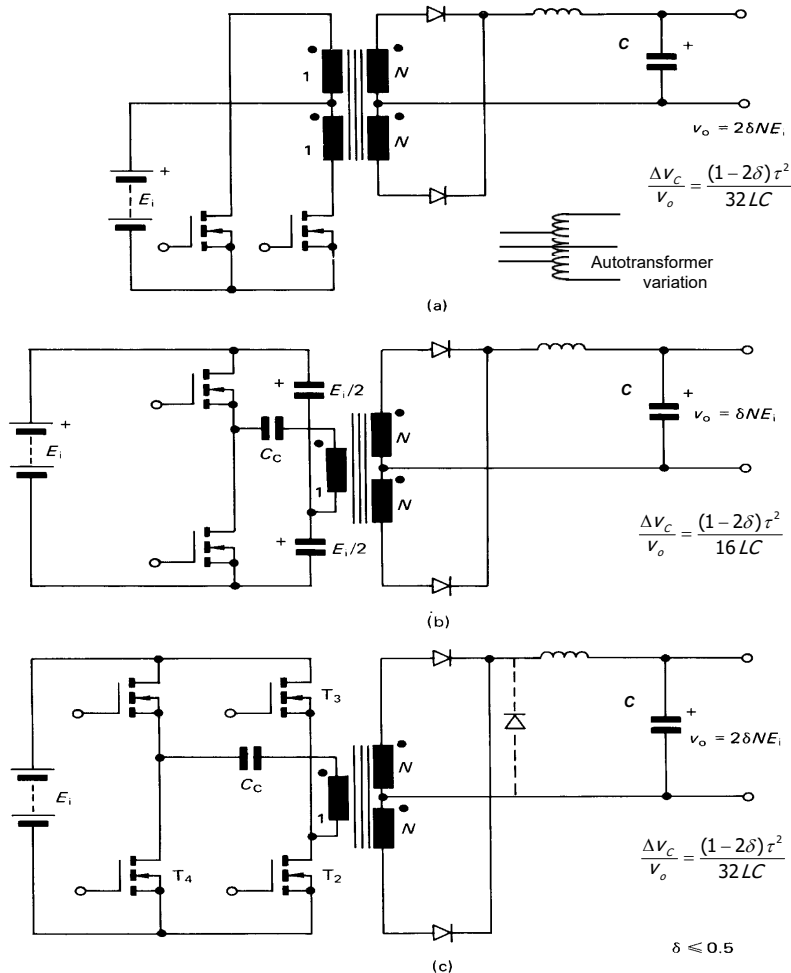

Figure 19.26. Multiple-switch, isolated output, pulse-width modulated converters: (a) push-pull plus autotransformer option; (b) half-bridge; and (c) full-bridge.

19.9.1 The push-pull converter

Figure 19.26a illustrates a push-pull forward converter circuit which employs two switches and a centre-tapped transformer. Each switch must have the same duty cycle in order to prevent unidirectional core saturation. Because of transformer coupling action, the off switch supports twice the input voltage, $2E_i$, plus any voltage associated with leakage inductance stored energy. Advantageously, no floating gate drives are required and importantly, no switch shoot through (simultaneous conduction) can occur.

The voltage transfer function, for continuous inductor current conduction, is based on the equivalent secondary output circuit shown in figure 19.27. Because of transformer action, the input voltage is $N \times E_i$, where N is the transformer turns ratio. When a primary switch is on, current flows in the outer loop shown in figure 19.27. That is

$$\Delta I_L = \hat{I}_L - \check{I}_L = \frac{N \times E_i - V_o}{L} \times t_r \quad (19.167)$$

When the primary switches are off, the secondary voltage falls to zero and current continues to flow through the secondary winding due to the energy stored in L . Efficiency is increased if the diode D_i is used to bypass the transformer winding, as shown in figure 19.27. The secondary winding $i^2 R$ losses are decreased and minimal voltage is coupled from the secondary back into the primary circuit. The current in the inner off loop shown in figure 19.27 is given by

$$\Delta I_L = \frac{V_o}{L} \times (\tau - t_r) \quad (19.168)$$

Equating equations (19.167) and (19.168) gives the following voltage and current transfer function

$$\frac{V_o}{E_i} = \frac{\bar{I}_L}{I_o} = 2N \frac{t_r}{\tau} = 2N\delta \quad 0 \leq \delta \leq \frac{1}{2} \quad (19.169)$$

The output voltage ripple is similar to that of the forward converter

$$\frac{\Delta V_c}{V_o} = \frac{\Delta V_o}{V_o} = \frac{(1-2\delta)\tau^2}{32LC} \quad (19.170)$$

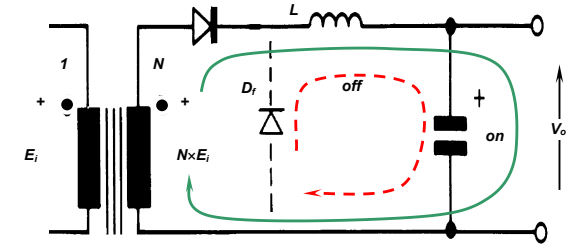

Figure 19.27. Equivalent circuit for transformer bridge converters based on a forward converter in the secondary.

Converter semiconductor utilisation ratio

The total converter semiconductor utilisation is represented by the factor U_f :

$$U_f = \frac{P_{rated}}{\sum_{VSI} V_{max} I_{rms}} = \frac{\delta}{2\sqrt{\delta} + \sqrt{1-2\delta}} \quad (19.171)$$

19.9.2 Bridge converters

Figures 19.26b and c show half and full-bridge isolated forward converters respectively.

i. Half-bridge

In the half-bridge the transistors are switched alternately and must have the same conduction period. This ensures the core volts-second balance requirement to prevent saturation due to bias in one flux direction.

Using similar analysis as for the push-pull converter in 19.9.1, the voltage transfer function of the half bridge with a forward converter output stage, for continuous inductor conduction, is given by

$$\frac{V_o}{E_i} = \frac{\bar{I}_L}{I_o} = N \frac{t_r}{\tau} = N\delta \quad 0 \leq \delta \leq \frac{1}{2} \quad (19.172)$$

A floating base drive is required. Although the maximum winding voltage is $\frac{1}{2}E_i$, the switches must support E_i in the off-state, when the complementary switch conducts.

The output ripple voltage is given by

$$\frac{\Delta V_c}{V_o} = \frac{\Delta V_o}{V_o} = \frac{(1-2\delta)\tau^2}{16LC} \quad (19.173)$$

Converter semiconductor utilisation ratio

The total converter semiconductor utilisation is represented by the factor U_f :

$$U_f = \frac{P_{rated}}{\sum_{V_{max}} I_{rms}} = \frac{\delta \delta'}{\sqrt{\delta} + \sqrt{\delta'}} \quad (19.174)$$

ii. Full-bridge

The full bridge in figure 19.26c replaces the capacitor supplies of the half-bridge converter with switching devices. In the off-state each switch must support the rail voltage E_i and two floating gate drive circuits are required. This bridge converter is usually reserved for high-power applications.

Using similar analysis as for the push-pull converter in 19.9.1, the voltage transfer function of the full bridge with a forward converter output stage, with continuous inductor conduction is given by

$$\frac{V_o}{E_i} = \frac{\bar{I}_i}{I_o} = 2N \frac{t_r}{\tau} = 2N\delta \quad 0 \leq \delta \leq \frac{1}{2} \quad (19.175)$$

Any volts-second imbalance (magnetising flux build-up) can be minimised by using dc blocking capacitance C_o , as shown in figures 19.26b and c.

The output ripple voltage is given by

$$\frac{\Delta V_c}{V_o} = \frac{\Delta V_o}{V_o} = \frac{(1-2\delta)\tau^2}{32LC} \quad (19.176)$$

Converter semiconductor utilisation ratio

The total converter semiconductor utilisation is represented by the factor U_f :

$$U_f = \frac{P_{rated}}{\sum_{V_{max}} I_{rms}} = \frac{2\delta}{2(\sqrt{2} + \sqrt{\delta} + \sqrt{\delta'}) + \sqrt{2}} \quad (19.177)$$

Output stage variations

In each forward converter in figure 19.26, a single secondary transformer winding and full-wave rectifier can be used. Better copper utilisation results. If the output diode shown dashed in figure 19.26c is used, the off state loop voltage is decreased from two diode voltage drops to one. The core magnetising current conducts through the secondary winding into the load circuit.

The three converters in figure 19.26 all employ the same forward converter output stage, so the critical load resistance for continuous inductor current is the same for each case, viz.,

$$R_{crit} = \frac{4L}{\tau(1-2\delta)} \quad (19.178)$$

Re-arrangement of this equation gives an expression for minimum inductance in terms of the load resistance.

If the output inductor is not used, conventional unregulated transformer square-wave voltage ratio action occurs for each transformer based smps, where, independent of δ :

$$\frac{V_o}{E_i} = \frac{\bar{I}_i}{\bar{I}_o} = \frac{n_s}{n_o} = N \quad (19.179)$$

Zero voltage switching (ZVS) of the H-bridge semiconductors

The H-bridge load circuit in figure 19.26 parts b and c, is a transformer, and all transformers have leakage inductance. This leakage inductance can be utilised as a turn-on snubber, producing H-bridge zero voltage switching ZVS conditions, which eliminate both switch turn-on losses and diode reverse recovery current injection problems. A consequence of ZVS is purely capacitive snubbers (no snubber diode or reset resistor) also become lossless.

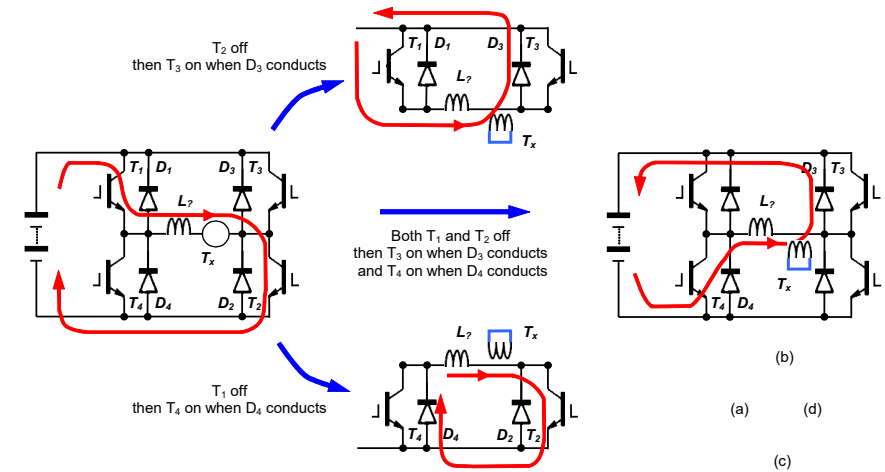

Figure 19.28. H-bridge current conduction paths: (a) switches T_1 and T_2 conducting; (b) switch T_2 off and then T_3 on; (c) switch T_1 off and then T_4 on; and (d) switches T_1 and T_2 off, then T_3 and T_4 on.

The sequence of circuit diagrams in figure 19.28 illustrate how the transformer leakage inductance is used to achieve ZVS.

When any switch that is conducting current is turned off, current associated with the leakage inductance diverts to a diode, as shown in the off-loops in figures 19.28 parts b, c, and d. The switch in anti-parallel with that conducting diode in figure 19.28 can be turned on, while the diode conducts, without any switch turn-on losses, ZVS. The magnetising current circulates in a zero volt loop created in the secondary, as shown in figure 19.28. The zero volt loops, figures 19.28 b and c, are alternated on a cycle-by-cycle basis. At a maximum duty cycle, the negative voltage sequence in figure 19.28d is used, where the leakage inductance current falls rapidly to zero.

An inherent consequence of ZVS is that lossless capacitive turn-off snubbers can be employed across the bridge switches, as highlighted in chapter 21.1.1ii and figure 18.6a. The snubber capacitance can be optimally designed if the converter is operated in a constant current mode.

Effect of transformer leakage inductance on H bridge performance

Consideration of transformer leakage inductance means the dc output inductor can be dispensed with, provided the modified transfer characteristics are acceptable, as shown in figure 19.29. The incentive for eliminating the dc output inductor is related to the output diode bridge adverse reverse voltage recovery performance. With a dc output inductor, transformer leakage energy produces a high reverse recovery voltage across the rectifier when the diodes commutate. Without the dc inductor, the output diodes are clamped by the output capacitor C_{out} in figure 19.29.

When accounting for leakage inductance, the voltage transfer ratio is given by

$$\frac{V_o}{E_i} = (4\delta - 1)N \quad \delta < \frac{1}{2} \quad (19.180)$$

The input and output current ripple are

$$\Delta V_{in} C_{in} = I_{in} \delta \delta'^2 \tau \quad (19.181)$$

$$\Delta V_{out} C_{out} = \frac{1}{8} \frac{\Delta I_{L1} I_{out} \delta \tau}{1 - 2\delta}$$

The converter semiconductor utilisation ratio is, for $N=1$:

$$U_f = \frac{\sqrt{2}\sqrt{3}(4\delta - 1)}{8(2\sqrt{2}\sqrt{\delta} - 4\delta + 1)} \quad (19.182)$$

Section 10.9 considers diode bridge voltage clamping when an output dc inductor is employed in transformer coupled circuits.

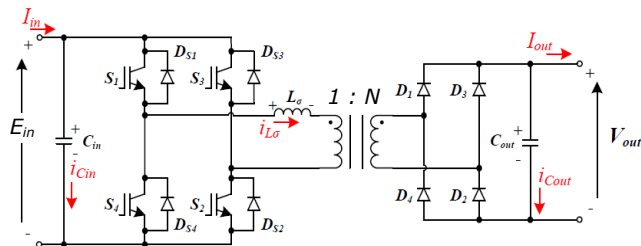

Figure 19.29. H-bridge with transformer leakage but without a dc output inductor.

Reading list

- Fisher, M. J., *Power Electronics*, PWS-Kent Publishing, 1991.
- Hart, D.W., *Introduction to Power Electronics*, Prentice-Hall, Inc, 1994.
- Hnatek, E. R., *Design of Switch Mode Power Supplies*, Van Nostrand Reinhold, 1981.
- Mohan, N., *Power Electronics*, 3rd Edition, Wiley International, 2003.
- Thorborg, K., *Power Electronics – in theory and practice*, Chartwell-Bratt, 1993.

<http://www.ipes.ethz.ch/>

Problems

- 19.1. An smps is used to provide a 5V rail at 2.5A. If 100 mV p-p output ripple is allowed and the input voltage is 12V with 25 per cent tolerance, design a flyback buck-boost converter which has a maximum switching frequency of 50 kHz.
- 19.2. Derive the following design equations for a flyback boost converter, which operates in the discontinuous mode.
- $$\hat{i}_i = 2 \times \bar{I}_o(\max) \times \frac{V_o}{E_i(\min)} = \text{constant}$$
- $$t_D = \frac{1}{f_{(\max)} \frac{V_o}{E_i(\min)}}$$
- $$L = t_{r(\min)} \frac{V_o - E_i(\min)}{\hat{i}_i}$$
- $$f = \frac{1}{\tau} = f_{(\max)} \frac{\bar{I}_o}{\bar{I}_o(\max)} \times \frac{V_o - E_i}{V_o - E_i(\min)}$$
- $$C = \frac{\Delta Q}{\Delta e_o} = \frac{\hat{i}_i t_{r(\min)}}{2\Delta e_o}$$
- $$ESR_{(\max)} = \frac{\Delta e_o}{\hat{i}_i}$$
- 19.3. Derive design equations for the forward non-isolated converter, operating in the continuous conduction mode.
- 19.4. Prove that the output rms ripple current for the forward converter in figure 19.2 is given by $\Delta i_o / 2\sqrt{3}$.

- 19.5. If the smps inductor has series resistance r , show that the voltage transfer function of the boost converter, with continuous inductor current, is given by

$$\frac{V_o}{E_i} = \frac{1}{1-\delta} \times \frac{1}{1 + \frac{r}{R(1-\delta)^2}}$$

where R is the load resistance. Hence show that the power transfer efficiency is

$$\eta = \frac{1}{1 + \frac{r}{R(1-\delta)^2}}$$

- 19.6. Show that the output voltage of a forward converter is decreased by $\delta v_{sw} + (1-\delta)v_D$ when the switch voltage drop is v_{sw} and the diode forward voltage drop is v_D .
- 19.7. In the forward converter example 19.1, the load resistance is varied between 1Ω and 16Ω, over which range the inductor current becomes discontinuous. With the aid of table 19.2, plot the output voltage as a function of load resistance over the range 1Ω to 16Ω.
- 19.8. In the step-up converter example 19.3, the load resistance is varied between 2½Ω and 22½Ω, and the inductor current becomes discontinuous at 22½Ω. With the aid of table 19.2, plot the output voltage as a function of load resistance over the range 2.5Ω to 45Ω.
- 19.9. In the step-up converter example 19.4, the load resistance is varied between 2½Ω and 37½Ω, and the inductor current becomes discontinuous at 37½Ω. With the aid of table 19.2, plot the output voltage as a function of load resistance over the range 2½Ω to 75Ω.
- 19.10. The forward converter in example 19.1 dissipates 9.216kW. Specify the necessary inductance change so that the minimum inductor current is 25% of the average inductor current.
- 19.11. A boost converter has a 12V input voltage and dissipates into a load 960W when the output is 48V. If the inductor ripple current is 50% of the average inductor current, determine the duty cycle and inductance when the switching frequency is 20kHz. If the output voltage ripple is restricted to a maximum of 1%, determine the minimum output capacitance.
- 19.12. A buck-boost converter has a 12V input voltage and dissipates into a load 960W when the output is -48V. If the inductor ripple current is 50% of the average inductor current, determine the duty cycle and inductance when the switching frequency is 20kHz. If the output voltage ripple is restricted to a maximum of 1%, determine the minimum output capacitance.
- 19.13. The isolated flyback converter in figure 19.21c has an input voltage of 50V, an output of 25V, an on-state duty cycle ratio of 0.4, and a 20kHz switching frequency. If the load is a 5Ω resistor, determine
- the transformer turns ratio
 - the core self-inductance such that the ripple current is half its average current.
- 19.14. The isolated forward converter in figure 19.21a has the following specification: $E_i = 96V$, $N_1:N_2:N_3 = 1$ with 4mH self-inductance, filter inductance 250μH, load resistance 24Ω, onstate duty cycle = 0.4 and a 40kHz switching frequency. Determine
- the output voltage and output ripple voltage if $C=220\mu F$
 - average and p-p current in the 250μH output inductor
 - the peak magnetising current in the model self inductance
 - peak switching current.
- 19.15. The push-pull converter in figure 19.7a has the following specification: $E_i=96V$, $N_p:N_s=1:1:2$ with 500μH of output inductance with respect to the primary, 12Ω load resistance, and a 25kHz switching frequency. For an on-state duty cycle of ½ determine
- the output voltage
 - the average and p-p output-inductance current
 - the output voltage ripple across a 470μF output capacitor.
- Sketch the switch, diode, source, and capacitors currents, using the inductor current as reference.

- 19.16. Repeat problem 19.15 if the core magnetising inductance (self-inductance) is 2.5mH with respect to the primaries. Having determined the peak magnetising current, add the magnetising inductance current waveform to the other sketched waveforms.
- 19.17 A forward converter operates at 50kHz with a 60% duty cycle from a 15V dc supply and delivers 27W into a resistive load. Determine the output voltage and inductor rms current. Sketch the capacitor and inductor current and voltage waveforms. What output capacitance will result in 1% output voltage ripple? What inductance will ensure continuous conduction at 3W output?

blank