

CHAPTER 18

DC to AC Inverters – *Resonant Mode*

Inversion (in this chapter) is the conversion of dc power to ac power at a desired output voltage or current and frequency. A static semiconductor inverter circuit performs this electrical energy inverting transformation. The terms voltage-source and current-source are used in connection with the output from inverter circuits.

A *voltage-source inverter (VSI)* is one in which the dc input voltage is essentially constant and independent of the load current drawn. The inverter specifies the load voltage while the drawn current shape, near sinusoidal, is dictated by the series resonant load, in this case.

A *current-source inverter (CSI)* is one in which the source, hence the load current is predetermined and the load impedance, a parallel resonant circuit in this case, determines the near sinusoidal output voltage. The supply current cannot change quickly. This current is controlled by series dc supply inductance which prevents sudden changes in current. Being a current source, the inverter can survive an output short circuit thereby offering fault ride-through properties.

Inverter switching losses (either turn-on or turn-off) can be significantly reduced if zero current or voltage switching can be utilised. This switching loss reduction allows higher operating frequencies hence smaller L and C components (in size, weight, and value). Radiated switching noise is significantly reduced.

Two main techniques can be used to achieve near zero switching losses

- a resonant load that provides natural voltage or current zero instances for switching or
- a resonant circuit across the switch which feeds energy to the load as well as introducing zero current or voltage instances for switching.

The inverter and its output are single-phase and the output is controlled around the load resonant frequency. Zero current, ZCS, and zero voltage, ZVS, switching occurs when the inverter switches are operated either side of resonance, while both ZCS and ZVS coincide at resonance.

18.1 Resonant dc-ac inverters

The voltage source inverters considered in 17.1 involve inductive loads and the use of switches that are hard switched. That is, the switches experience simultaneous maximum voltage and current during turn-on and turn-off with an inductive load. The current source inverters considered in 17.2 required capacitive circuits to commutate the bridge switches. When self-commutable devices are used in current source inverters, hard switching occurs. In resonant inverters, the load enables commutation of the bridge switches with near zero voltage or current switch conditions, resulting in low switching losses.

A characteristic of L - C - R resonant circuits is that at regular, definable instants

- for a step load voltage, the series L - C - R load current sinusoidally reverses or
- for a step load current, the parallel L - C - R load voltage sinusoidally reverses.

If the load can be resonated, as considered in chapter 7.2.3, then switching stresses can be significantly reduced for a given power through put, provided switching is synchronised to the V or I zero crossing.

Three types of resonant converters utilise zero voltage or zero current switching.

- load-resonant converters
- resonant-switch dc-to-dc converters
- resonant dc link and forced commutated converters

The single-phase load-resonant converter, which is extensively used in induction heating applications, is presented and analysed in this chapter. Such resonant load converters use an L - C load which oscillates, thereby providing load zero current or voltage intervals at which the converter switches can be commutated with minimal electrical stress. Resonant switch dc-to-dc converters are presented in chapter 21.

Two basic resonant-load single-phase inverters are used, depending on the L - C load arrangement:

- current source inverter with a parallel L - C resonant (tank) load circuit:
 - switch turn-off at zero load voltage instants and turn-on with zero voltage
 - switch overlap is essential (a continuous source current path is required)
- voltage source inverter with a series connected L - C resonant load:
 - switch turn-off at zero load current instants and turn-on with zero current
 - switch under lap is essential (to avoid dc voltage source short circuiting)

Each load circuit type can be fed from a single leg (or arm) circuit or H-bridge circuit depending on the load Q factor, as shown in the parts of figure 18.2. This classification is divided according to

- symmetrical full bridge for low Q load circuits (class D – figure 18.2b, d)
- single bridge leg circuit for a high Q load circuit (class E – figure 18.2a, c)

High Q circuits can also use a full bridge inverter configuration, if desired, for higher through-put power. In induction heating applications, the resistive part of the resonant load, called the work-piece, is the active load to be heated - melted, where the heating load is usually transformer coupled. Energy transfer control complication is usually associated with the fact that the resistance of the load work-piece changes as it heats up and melts, since resistivity is temperature dependant. However, control is essentially independent of the voltage and current levels and is related to the resonant frequency which is L and C dependant. Inverter bridge operation is near the load resonant frequency so that the output waveform is essentially sinusoidal. By ensuring operation is below the resonant frequency, such that the load is capacitive, the resultant leading current can be used to self commutate thyristor converters which may be used in high power series resonant circuits. This same capacitive load commutation effect is obtained for parallel resonant circuits with thyristor current source inverters operating just above resonance. The output power is controlled by controlling the converter output frequency, with maximum power being transferred at the resonant frequency.

18.2 L-C resonant circuits

L - C - R resonant circuits, whether parallel or series connected are characterised by the load impedance being capacitive at low frequency and inductive at high frequency for the series circuit, and vice versa for the parallel case. The transition frequency between being capacitive and inductive is the resonant frequency, ω_o , at which frequency the L - C - R load circuit appears purely resistive and maximum power is transferred to the load, R . L - C - R circuits are classified according to circuit quality factor Q , resonant frequency, ω_o , and bandwidth, BW , for both parallel and series circuits. The characteristics for the parallel and series resonant circuits are related since every practical series L - C - R circuit has a parallel equivalent, and vice versa. The parallel circuit can be series R - L in parallel with the capacitor C .

As shown in figure 18.1 each resonant half cycle is characterised by

- the series resonant circuit current is zero at maximum capacitor stored energy
- the parallel resonant circuit voltage is zero at maximum inductor stored energy

The series resonant circuit must have an external path through which to release its stored energy. While at shut down, the parallel resonant circuit can release its stored energy within its parallel circuit, without an external circuit. The stored energy can internally resonate, transferring energy back and forth between the L and C , gradually dissipating energy in the circuit R , as heat.

18.2.1 - Series resonant L - C - R circuit

The series L - C - R circuit current for a step input voltage V_s , with initial capacitor voltage v_o and series inductor current i_o is given by

$$i(\omega t) = \frac{V_s - v_o}{\omega L} \times e^{-\alpha t} \times \sin \omega t + i_o \times e^{-\alpha t} \times \frac{\omega_o}{\omega} \times \cos(\omega t + \phi) \quad (18.1)$$

where

$$\omega^2 = \omega_o^2 (1 - \xi^2) = \omega_o^2 - \alpha^2 \quad \omega_o = \frac{1}{\sqrt{LC}} \quad \alpha = \frac{R}{2L} \quad \frac{1}{2Q_s} = \xi = \frac{R}{2\omega_o L} \quad \text{and} \quad \tan \phi = \frac{\alpha}{\omega}$$

ξ is the damping factor. The capacitor voltage is important because it specifies the energy retained in the L - C - R circuit at the end of each half cycle.

$$v_c(\omega t) = V_s - (V_s - v_o) \frac{\omega_o}{\omega} e^{-\alpha t} \cos(\omega t - \phi) + \frac{i_o}{\omega C} e^{-\alpha t} \sin \omega t \quad (18.2)$$

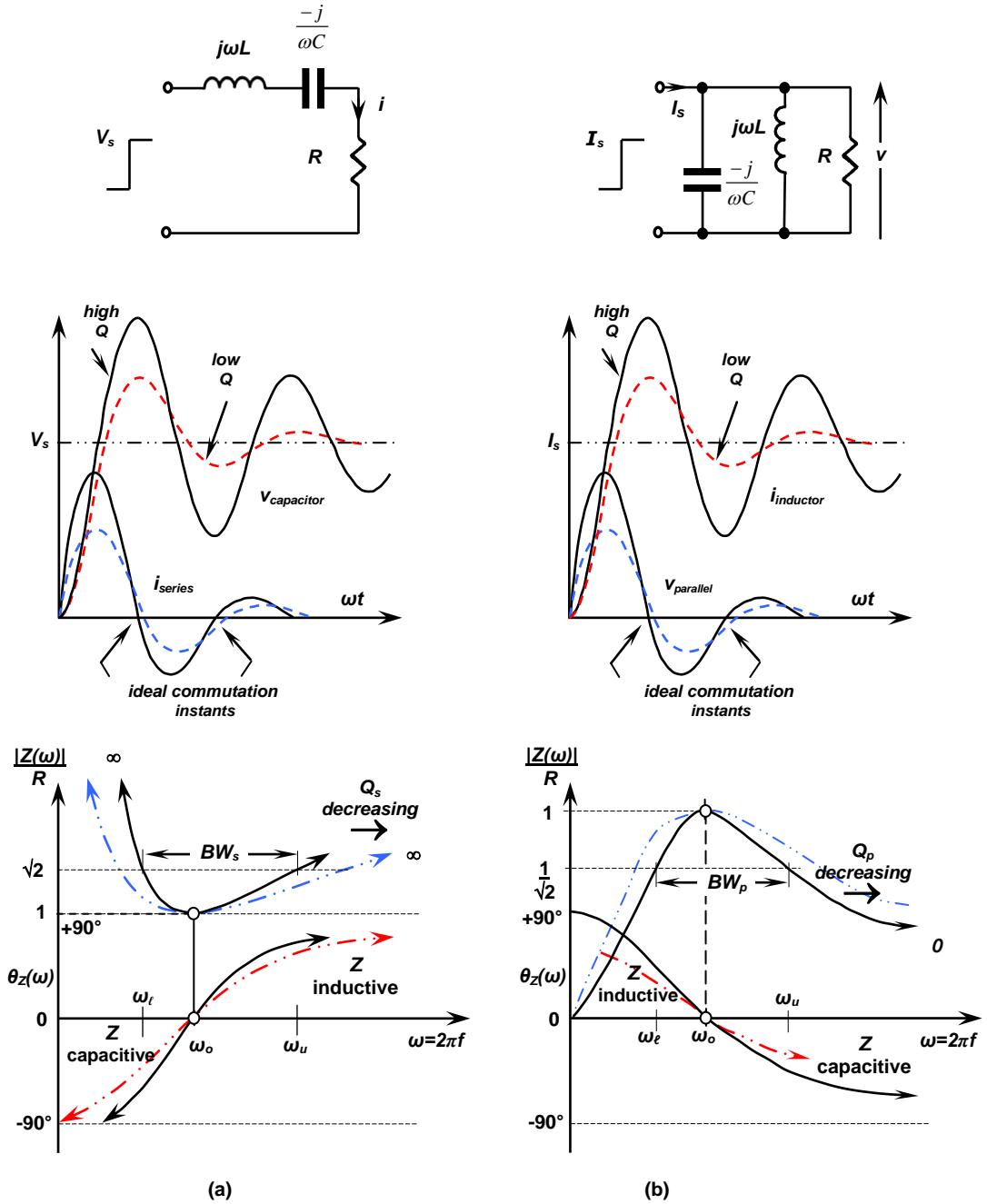

Figure 18.1. Resonant circuits, step response, and frequency characteristics: (a) series L-C-R circuit and (b) parallel L-C-R circuit.

At the series circuit resonance frequency ω_o , the lowest possible circuit impedance results, $Z = R$ as shown in figure 18.1a, hence it can be termed, *low-impedance resonance*. The series circuit *quality factor* or figure of merit, Q_s , is defined by

$$\begin{aligned}
 Q_s &= \frac{\text{reactive power}}{\text{average power}} = \frac{2\pi \times \text{maximum (peak) stored energy}}{\text{energy dissipated per cycle}} \\
 &= \frac{2\pi \cdot \frac{1}{2} Li^2}{\frac{1}{2} Ri^2 / f_o} = \frac{\omega_o L}{R} = \frac{1}{2\xi} = \frac{Z_o}{R}
 \end{aligned}
 \tag{18.3}$$

where the characteristic impedance is

$$Z_o = \sqrt{\frac{L}{C}} \quad (\Omega)$$

The series circuit half-power bandwidth BW_s is given by

$$BW_s = \frac{\omega_o}{Q_s} = \frac{2\pi f_o}{Q_s}
 \tag{18.4}$$

and upper and lower half-power frequencies are related by $\omega_o = \sqrt{\omega_l \omega_u}$.

$$\omega_c^u = \omega_o \pm \alpha = \omega_o \pm \frac{R}{2L}$$

$$f_c^u = f_o \pm \frac{R}{4\pi L}$$
(18.5)

Figure 18.1a shows the time-domain step-response of the series L - C - R circuit for a high Q load and a lower Q case. In the lower Q case, to maintain and transfer sufficient energy to the load R , the circuit requires re-enforcement every half sine cycle, while with a high circuit Q , re-enforcement is only necessary once per sinusoidal cycle. Thus for a high circuit Q , full bridge excitation is not essential, yielding a simpler power circuit as shown in figure 18.2a and b.

Table 18.1: Characteristics and parameters of parallel and series resonant circuits

characteristic		series	parallel
Resonant period/time constant	s	$\tau = \sqrt{LC}$	
Resonant angular frequency	rad/s	$\omega_o = 2\pi f_o = \frac{1}{\tau} = \frac{1}{\sqrt{LC}}$	
Damping factor	pu	$\xi_s = \frac{1}{2} \frac{R}{\omega_o L} = \frac{1}{2} \omega_o C R$	$\xi_p = \frac{1}{2} \frac{\omega_o L}{R} = \frac{1}{2} \frac{1}{\omega_o C R}$
Damping constant	/s	$\alpha_s = \frac{R}{2L}$	$\alpha_p = \frac{1}{2CR}$
Characteristic impedance	Ω	$Z_o = \sqrt{\frac{L}{C}} = \omega_o L = \frac{1}{\omega_o C}$	
Damped resonant angular frequency $\omega = \omega_o \sqrt{1 - \xi^2} = \sqrt{\omega_o^2 - \alpha^2}$	rad/s	$\omega = \omega_o \sqrt{1 - \xi_s^2}$	$\omega = \omega_o \sqrt{1 - \xi_p^2}$
Quality factor $Q_s = \frac{1}{Q_p}$	pu	$Q_s = \frac{1}{2\xi_s} = \frac{Z_o}{R} = \frac{\sqrt{L/C}}{R} = \frac{\omega_o L}{R}$ $= \frac{1}{\omega_o C R} = \frac{2\pi(\frac{1}{2} L I_p^2)}{(\frac{1}{2} R I_p^2) \tau}$	$Q_p = \frac{1}{2\xi_p} = \frac{R}{Z_o} = \frac{R}{\sqrt{L/C}} = \omega_o C R$ $= \frac{R}{\omega_o L} = \frac{2\pi(\frac{1}{2} C V_p^2)}{(\frac{1}{2} V_p^2 / R) \tau}$
Bandwidth	rad/s	$BW_s = \frac{\omega_o}{Q_s}$	$BW_p = \frac{\omega_o}{Q_p}$
At resonance $\omega = \omega_o$	pu	$\frac{V_c}{V_s} = -jQ_s$	$\frac{i_c}{I_s} = jQ_p$
At resonance $\omega = \omega_o$	pu	$\frac{V_L}{V_s} = jQ_s$	$\frac{i_L}{I_s} = -jQ_p$

The energy transferred to the load resistance R , per half cycle $1/2f_r$, is

$$W_{\frac{1}{2}} = \int_0^{\pi} i(\omega t)^2 R d\omega t$$
(18.6)

The active power transferred to the load depends on the repetition rate of the excitation, f_r .

$$P = W_{\frac{1}{2}} \times f_r \quad (\text{W})$$
(18.7)

18.2.2 - Parallel resonant L - C - R circuit

The load for the parallel case is a parallel L - C circuit, where the active load is represented by series resistance in the inductive path. For analysis, the series L - R circuit is converted into its parallel R - L equivalent circuit, thus forming the equivalent parallel L - C - R circuit shown in figure 18.1b. A parallel resonant circuit is used in conjunction with a current source inverter, thus the parallel circuit is excited with a step input current. The voltage across a parallel L - C - R circuit for a step input current I_s , with initial capacitor voltage v_o and initial inductor current i_o is given by

18.3 Series-load, series resonant voltage-source inverters

Series resonant circuits use a voltage source inverter (class D series) as considered in 18.1.1 and shown in figure 18.3a and b. If the load Q is high, then the resonance of energy from the energy source, V_s , need only be re-enforced every second half-cycle, thereby simplifying converter and control requirements. A high Q circuit is characterised by successive half-cycle capacitor voltage peak magnitudes being of similar magnitude, that is the decay rate is

$$\frac{V_{c_n}}{V_{c_{n+1}}} = e^{\frac{\pi}{2Q}} \approx 1 \quad \text{for } Q \gg 1 \quad (18.14)$$

Thus there is sufficient energy stored in C to be transferred to the load R , without need to involve the supply V_s . The circuit in figure 18.3a is simpler and control is easier.

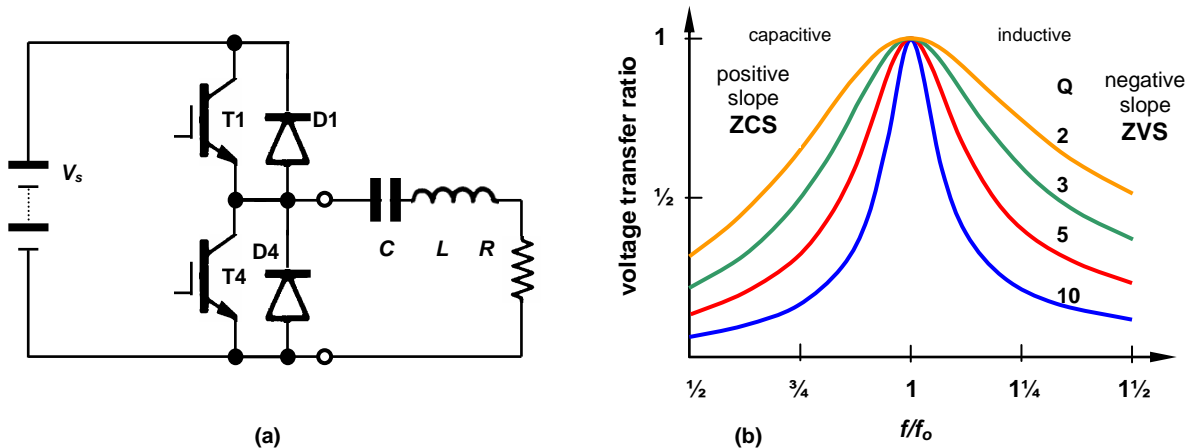

Figure 18.3. Series resonant voltage source converter: (a) circuit and (b) voltage transfer function.

Also, for any Q , each converter can be used with or without the shown freewheel diodes. Without freewheel diodes, the switches have to block high reverse voltages due to the energy stored by the capacitor. MOSFET and IGBTs require series diodes to achieve the reverse voltage blocking requirements. In high power resonant applications, the reverse blocking abilities of the GTO and GCT make them ideal converter switches. Better load resonant control is obtained if freewheel diodes are not used.

18.3.1 – Series-resonant voltage-source inverter – single inverter leg

Operation of the series load single leg circuit in figure 18.3a depends on the timing of the switches.

1 - Lagging operation (advancing the switch turn-off angle, $f > f_0$)

If the converter is operated at a frequency above resonance (effected by commutating the switches before the end of an oscillation cycle), the inductor reactance dominates and the load appears inductive. The load current lags the voltage as shown in figure 18.4. This figure shows the conducting devices and that a switch is turned on when its parallel connected diode is conducting. Turn-on therefore occurs at a low voltage (hence low switch turn-on loss and no need for fast recovery diodes), while turn-off (pre-mature) is as with a hard switched inductive load (associated with switch high turn-off loss and turn-off Miller capacitance effects). The turn-off switching loss can be eliminated by adding a shunt capacitor across one of the leg switches and using a dead time between the gate drive voltages.

Operation and switch timing are as follows:

Switch T1 is turned on while its anti-parallel diode D1 is conducting and the current in the diode reaches zero and the current transfers to, and begins to oscillate through the switch T1. The capacitor charges to a maximum voltage and before the current reverses, the switch T1 is hard turned off. The current is diverted through diode D4. T4 is turned on which allows the oscillation to reverse. Before the current in T4 reaches zero, it is turned off and current is diverted to diode D1, which returns energy to the supply. The resonant cycle is repeated when T1 is turned on before the current in diode D1 reaches zero and the process continues.

2 - Leading operation (delaying the switch turn-on angle, $f < f_0$)

By operating the converter at a frequency below resonance (effectively by delaying switch turn-on until after the end of an oscillation cycle), the capacitor reactance dominates and the load appears capacitive. The load current leads the voltage as shown in figure 18.5. This figure shows the conducting devices and that a switch is turned off when its parallel diode is conducting. Turn-off therefore occurs at a low current, while turn-on (diode reverse recovery) is as with a hard switched inductive load. Fast recovery diodes are therefore essential. Switch output capacitance charging and discharge ($\frac{1}{2}CV^2$) and the Miller effect at turn-on (requiring increased gate power) are factors to be accounted for.

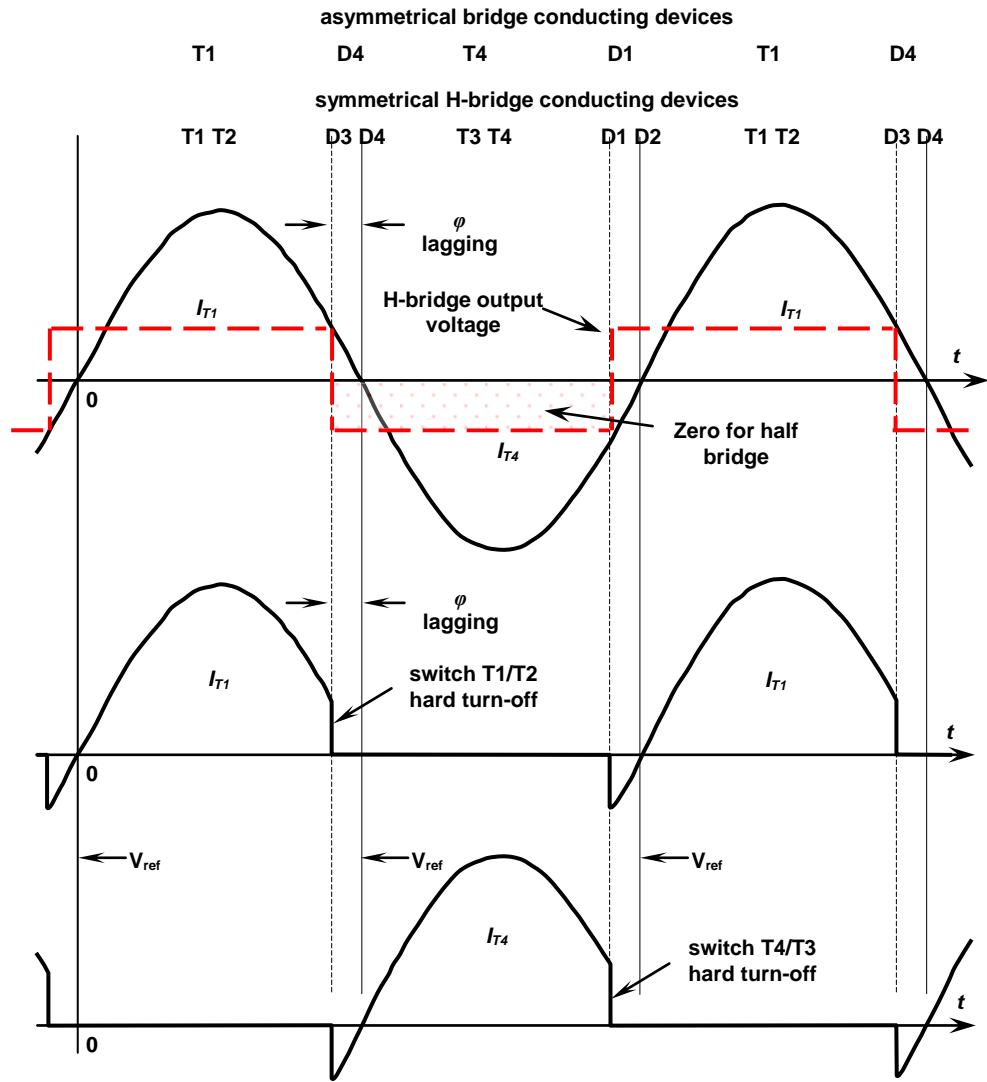

Figure 18.4. Series L-C-R high Q resonance using the converter circuit in figure 18.2a and b, with $f > f_{or}$, a lagging power factor ϕ .

Operation and switch timing are as follows:

Diode D4 is conducting when switch T1 is turned on, which provides a step input voltage V_s to the series L-C-R load circuit, and the current continues to oscillate. The capacitor charges to a maximum voltage and the current reverses through D1, feeding energy back into the supply. T1 is then turned off with zero current.

The switch T4 is turned on, commutating D1, and the current oscillates through the zero volt loop created through T4 and the load. The oscillation current reverses through diode D4, when T4 is turned off with zero current.

T1 is turned on and the process continues.

Without the freewheel diodes the half oscillation cycles are controlled completely by the switches. On the other hand, with freewheel diodes, the timing of switch turn-on and turn-off is determined by the load current zeros, if maximum energy transfer to the load is to be gained.

Analysis – single inverter leg – figure 18.3a

For a square wave input voltage, 0 to V_s , of frequency $\omega \approx \omega_o$, the input voltage fundament of magnitude $2V_s / \pi$ produces the dominant load current component, since higher frequency components are attenuated by second order L-C filtering action. That is, the resonant circuit excitation voltage is $|V_i| = 2V_s / \pi$. Key characteristic equations are $\omega_o = 1/\sqrt{LC}$, $Z_o = \sqrt{L/C}$, and $Q = Z_o/R$.

The series circuit steady-state current at resonance for the single-leg half-bridge can be approximated by assuming $\omega_o \approx \omega$, such that in equation (18.1) $i_o = 0$:

$$i(\omega t) = \frac{1}{1 - e^{-\frac{\alpha\pi}{\omega}}} \times \frac{V_s}{\omega L} \times e^{-\alpha t} \times \sin \omega t \quad 0 \leq \omega t \leq \pi \quad (18.15)$$

which is valid for the + V_s loop (through T1) and zero voltage loop (through T4) modes of cycle operation at resonance, provided the time reference is moved to the beginning of each half-cycle.

In steady-state the successive capacitor voltage absolute maxima are

$$\hat{V}_c = V_s \frac{1}{1 - e^{-\alpha\pi/\omega}} \quad \text{and} \quad \check{V}_c = -V_s \frac{e^{-\alpha\pi/\omega}}{1 - e^{-\alpha\pi/\omega}} \quad (18.16)$$

The peak-to-peak capacitor voltage is therefore

$$V_{c_{p-p}} = \frac{1 + e^{-\alpha\pi/\omega}}{1 - e^{-\alpha\pi/\omega}} \times V_s = V_s \times \coth(\alpha\pi / 2\omega) \approx \frac{2\omega}{\alpha\pi} \times V_s \quad (18.17)$$

The energy transferred to the load R , per half sine cycle (per current pulse) is

$$\begin{aligned} W &= \int_0^{\pi/\omega} i^2 R dt = \int_0^{\pi/\omega} \left(\frac{1}{1 - e^{-\alpha\pi/\omega}} \times \frac{V_s}{\omega L} \times e^{-\alpha t} \times \sin \omega t \right)^2 R dt \\ &= \frac{1}{2} C V_s^2 \coth^2(\alpha\pi / 2\omega) \end{aligned} \quad (18.18)$$

The input impedance of the series circuit is

$$Z_s = Z e^{j\varphi} = R + j \left(\omega L - \frac{1}{\omega C} \right) = R \left(1 + j Q_s \left(\frac{\omega}{\omega_o} - \frac{\omega_o}{\omega} \right) \right) = R (1 + j Q_s V) \quad (18.19)$$

where $\varphi = \tan^{-1} \left[Q_s \left(\frac{\omega}{\omega_o} - \frac{\omega_o}{\omega} \right) \right] = \tan^{-1} [Q_s V]$

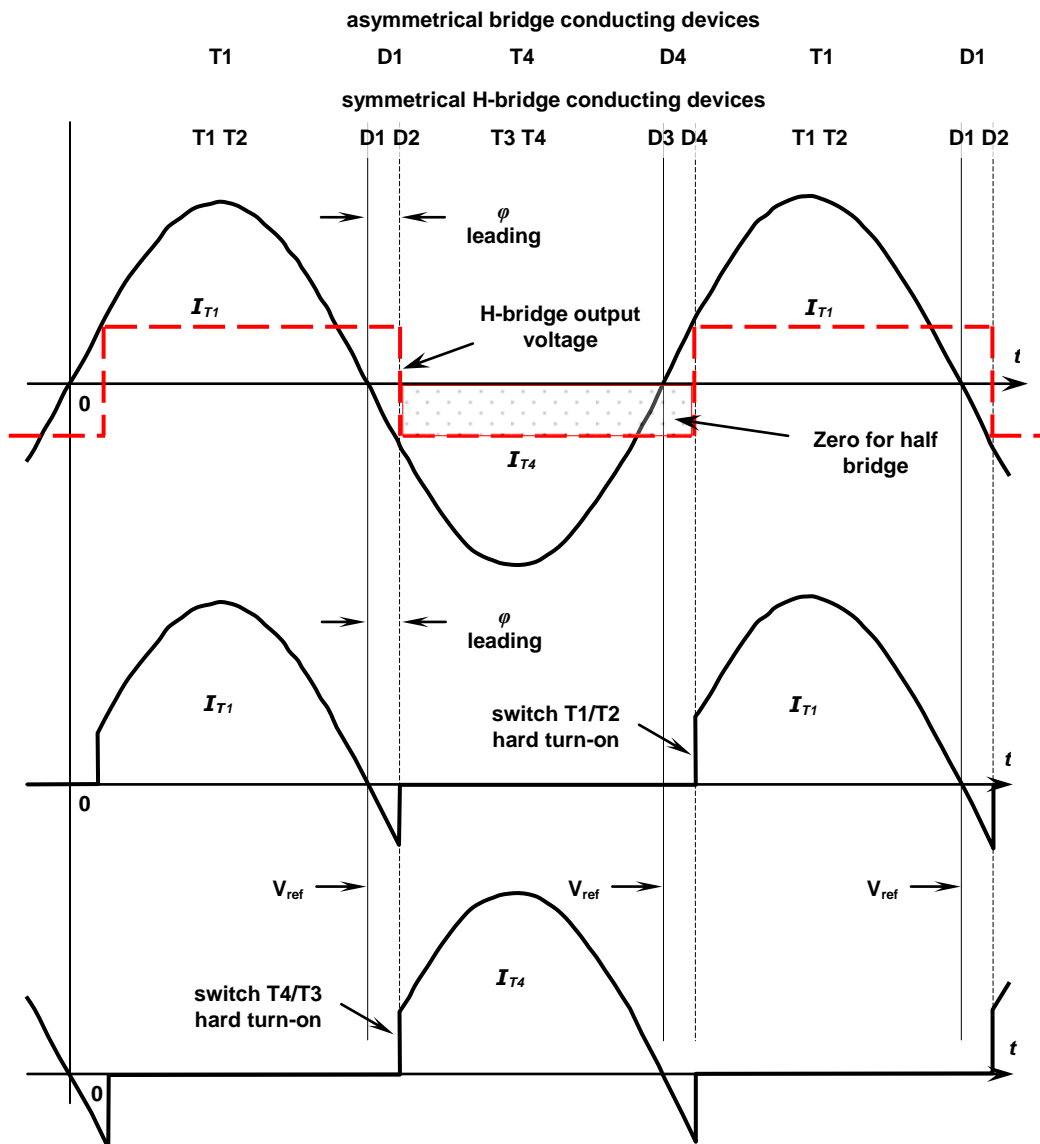

Figure 18.5. Series L-C-R high Q resonance using the converter circuit in figure 18.2a and b, with $f < f_{or}$, a leading power factor φ .

The frequency ratio terms in the equation for the input phase angle ϕ show that the resonant circuit is inductive ($\phi > 0$, lagging current) when $\omega > \omega_o$ and capacitive ($\phi < 0$, leading current) when $\omega < \omega_o$. From the series ac circuit, the voltage across the resistor, v_R , at a given frequency, ω , is given by

$$v_R(\omega) = V_i \frac{R}{R + j\left(\omega L - \frac{1}{\omega C}\right)} = V_i \frac{1}{1 + jQV} \quad (18.20)$$

The magnitude of the resistor voltage is therefore

$$\begin{aligned} v_R(\omega) &= V_i \frac{R}{\sqrt{R^2 + \left(\omega L - \frac{1}{\omega C}\right)^2}} = V_i \frac{1}{\sqrt{1 + \left(\frac{\omega L}{R} - \frac{1}{\omega RC}\right)^2}} \\ &= V_i \frac{1}{\sqrt{1 + Q^2 \left(\frac{\omega}{\omega_o} - \frac{\omega_o}{\omega}\right)^2}} = V_i \frac{1}{\sqrt{1 + Q^2 V^2}} \end{aligned} \quad (18.21)$$

18.3.2 – Series-resonant voltage-source inverter – H-bridge voltage-source inverter – figure 18.2b

When the load Q is not high, the capacitor voltage between successive absolute peaks decays significantly, leaving insufficient energy to maintain high efficiency energy transfer to the load R . In such cases the resonant circuit is re-enforced with energy from the dc source V_s every half-resonant cycle, by using a full H-bridge as shown in figure 18.2b.

Operation is characterised by turning on switches T1 and T2 to provide energy from the source during one half of the cycle, then having turned T1 and T2 off, T3 and T4 are turned on for the second resonant half cycle. Energy is again drawn from the supply V_s , and when the current reaches zero, T3 and T4 are turned off.

Without bridge freewheel diodes, the switches support high reverse bias voltages, but the switches control the start of each oscillation half cycle. With freewheel diodes the oscillations can continue independent of the switch states. The diodes return energy to the supply, hence reducing the energy transferred to the load. Correct timing of the switches minimises currents in the freewheel diodes, hence minimises the energy needlessly being returned to the supply. Net energy to the load is maximised. As with the single-leg half-bridge, the switches can be used to control the effective load power factor. By advancing turn-off to before the switch current reaches zero, the load can be made to appear inductive, while delaying switch turn-on produces a capacitive load effect. The timing sequencing of the conducting devices, for load power factor control, are shown in figures 18.4 and 18.5.

The series circuit steady-state current at resonance for the symmetrical H-bridge can be approximated by assuming $\omega_o \approx \omega$, such that in equation (18.1) $i_o = 0$:

$$i(\omega t) = \frac{2}{1 - e^{-\frac{\alpha\pi}{\omega}}} \times \frac{V_s}{\omega L} \times e^{-\alpha t} \times \sin \omega t \quad 0 \leq \omega t \leq \pi \quad (18.22)$$

which is valid for the $\pm V_s$ voltage loops of cycle operation at resonance, provided the time reference is moved to the beginning of each half-cycle.

In steady-state the capacitor voltage absolute maxima are

$$\hat{V}_c = V_s \frac{1 + e^{-\alpha\pi/\omega}}{1 - e^{-\alpha\pi/\omega}} = V_s \times \coth(\alpha\pi / 2\omega) = -\check{V}_c \quad (18.23)$$

The peak-to-peak capacitor voltage is therefore

$$V_{c_{p-p}} = 2 \times \frac{1 + e^{-\alpha\pi/\omega}}{1 - e^{-\alpha\pi/\omega}} V_s = 2V_s \coth(\alpha\pi / 2\omega) \approx \frac{4\omega}{\alpha\pi} \times V_s \quad (18.24)$$

The energy transferred to the load R , per half sine cycle (per current pulse) is

$$W = \int_0^{\pi/\omega} i^2 R dt = \int_0^{\pi/\omega} \left(\frac{2}{1 - e^{-\frac{\alpha\pi}{\omega}}} \times \frac{V_s}{\omega L} \times e^{-\alpha t} \times \sin \omega t \right)^2 R dt = 2CV_s^2 \coth^2\left(\frac{\alpha\pi}{2\omega}\right) \quad (18.25)$$

Notice the voltage swing is twice that with the single-leg half-bridge, hence importantly, the power delivered to the load is increased by a factor of four.

From the series ac circuit, the voltage across the resistor, v_R , at a given frequency, ω , is given by

$$v_R(\omega) = V_i \frac{R}{R + j\left(\omega L - \frac{1}{\omega C}\right)} \quad (18.26)$$

The magnitude of the resistor voltage is therefore

$$\begin{aligned}
 v_R(\omega) &= V_i \frac{R}{\sqrt{R^2 + \left(\omega L - \frac{1}{\omega C}\right)^2}} = V_i \frac{1}{\sqrt{1 + \left(\frac{\omega L}{R} - \frac{1}{\omega RC}\right)^2}} \\
 &= V_i \frac{1}{\sqrt{1 + Q^2 \left(\frac{\omega}{\omega_o} - \frac{\omega_o}{\omega}\right)^2}}
 \end{aligned}
 \tag{18.27}$$

The frequency ratio terms in the equation for the input phase angle φ show that the resonant circuit is inductive ($\varphi > 0$, lagging current) when $\omega > \omega_o$ and capacitive ($\varphi < 0$, leading current) when $\omega < \omega_o$. These resonant circuit resistor expressions are the same as for the half bridge case except the input voltage V_i for the full bridge is twice that of the half bridge case, for the same supply voltage V_s .

If the input voltage V_i is expressed as a Fourier series then the resistor current can be derived in terms of the summation of all the harmonic components according to

$$\sum_{n=1}^{\infty} i_R(n\omega) = \sum_{n=1}^{\infty} v_R(n\omega) / R
 \tag{18.28}$$

For a square wave input voltage, $\pm V_s$, of frequency $\omega \approx \omega_o$, the input voltage fundamental of magnitude $4V_s/\pi$ produces the dominant load current component, since higher frequency components are attenuated by second order L - C filtering action. That is, $|V_i| = 4V_s/\pi$.

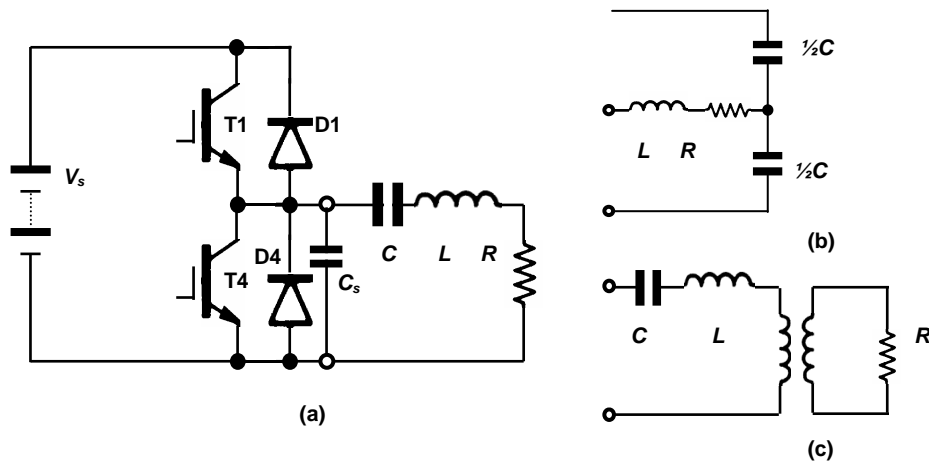

Figure 18.6. Different resonant load arrangements: (a) switch turn-off snubber capacitor C_s ; (b) split capacitor; and (c) series coupled circuit for induction heating.

18.3.3 - Series circuit variations

Figure 18.6a shows a single-leg half-bridge with a turn-off snubber C_s , where $C_s \ll C$, hence resonant circuit properties are not affected. The capacitive turn-off snubber is only effective if switch turn-off is advanced such that switch hard turn-off would normally result, that is, the resonant circuit appears capacitive. The snubber acts on both switches since small signal wise (short dc sources), switches T1 and T4 are in parallel.

Figure 18.6b shows a series resonant load used with split resonant capacitance which is in parallel, ac circuit wise. Resonance re-enforcement occurs every half cycle as with the full H-bridge topology, but only two switches are used.

Figure 18.6c shows a transformer-coupled series circuit, which allows the effective gain to exceed unity. Under light loads, the transformer magnetising current influences operation, whilst the transformer leakage inductance adds to the series inductance. Transformer coupling should only be used in full bridge configuration in order to avoid core bias – saturation - due to asymmetrical voltage waveforms.

18.4 Parallel-load, series-resonant voltage-source inverter - single inverter leg

The load resistance R in this inverter is connected in parallel with the resonant capacitor (or inductor), as shown in figure 18.7a. As a result, if the load resistance is much higher than the reactance of the resonant capacitor, the current through the resonant inductor and the switches is virtually independent of the load. As the load resistance increases, the voltage across the resonant capacitor and the load increases, causing the output power to increase. Parallel in the voltage source case means that the load R is in parallel with one of the L - C resonant circuit components: not that L - C - R are all in parallel.

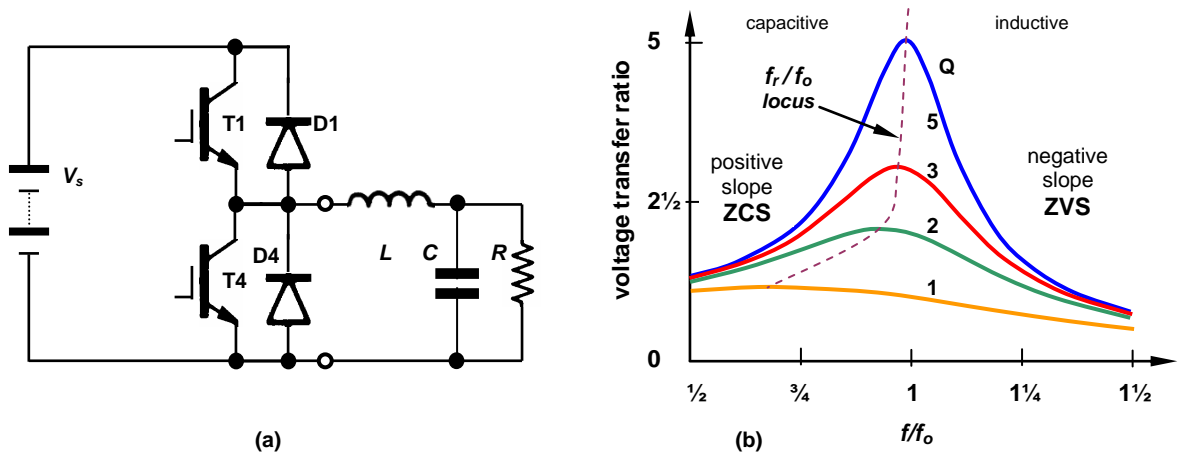

Figure 18.7. Parallel resonant voltage source converter: (a) circuit and (b) voltage transfer function.

The resonant circuit input impedance is

$$Z = Ze^{j\psi} = j\omega L + \frac{R \frac{1}{j\omega C}}{R + \frac{1}{j\omega C}} = \frac{R \left[1 - \left(\frac{\omega}{\omega_o} \right)^2 + j \frac{1}{Q} \frac{\omega}{\omega_o} \right]}{1 + jQ \frac{\omega}{\omega_o}} \quad \text{where } \psi = \tan^{-1} \left\{ Q \frac{\omega}{\omega_o} \left[\left(\frac{\omega}{\omega_o} \right)^2 + \frac{1}{Q^2} - 1 \right] \right\} \quad (18.29)$$

where $\omega_o = 1/\sqrt{LC} = f_o/2\pi$, $Z_o = \sqrt{L/C}$, and $Q = R/Z_o > 1$.

At resonance, with a large Q

$$Z(\omega_o) = \frac{Z_o}{\sqrt{Q^2 + 1}} \approx \frac{Z_o}{R} \quad (18.30)$$

The circuit resonant frequency, f_r , where the current phase shift is zero, is load R dependant (as opposed to the natural resonant frequency, f_o , which is defined by $\omega_o = 1/\sqrt{LC} = 2\pi f_o$), where

$$\frac{f_r}{f_o} = \sqrt{1 - \frac{1}{Q^2}} \quad \text{for } Q \geq 1 \quad (18.31)$$

When the bridge voltage excitation frequency is less than the circuit resonant frequency, $f < f_r$, the resonant circuit appears capacitive, and inductive if $f > f_r$.

The voltage gain magnitude (phase angle) transfer function, shown in figure 18.7b, is

$$v_R(\omega) = V_i \frac{R}{R + j\omega L(1 + j\omega CR)} \Rightarrow V_i \frac{1}{\sqrt{\left[1 - \left(\frac{\omega}{\omega_o} \right)^2 \right]^2 + \frac{1}{Q^2} \left(\frac{\omega}{\omega_o} \right)^2}}, \quad \phi = -\tan^{-1} \frac{1}{Q} \frac{\omega}{\omega_o} \left[1 - \left(\frac{\omega}{\omega_o} \right)^2 \right] \quad (18.32)$$

which for a large Q tends to

$$v_R(\omega) = V_i \frac{1}{1 - \left(\frac{\omega}{\omega_o} \right)^2} \quad \text{as } Q \rightarrow \infty \quad (18.33)$$

The output voltage can be in excess of the input voltage magnitude, with a maximum of $2Q^2/\sqrt{4Q^2 - 1}$.

18.5 Series-parallel-resonant voltage-source inverter – single inverter leg

The topology of this inverter is similar to that of the parallel resonant inverter except for an additional capacitor in series with the resonant inductor, or the same as that of the series resonant inverter except for an additional capacitor in parallel with the load, as shown in figure 18.8a. As a result, the LCC inverter exhibits third-order characteristics that are intermediate between those of the series and parallel resonant inverters. In particular, it has a high light-load efficiency.

The resonant circuit input impedance magnitude is

$$Z = Z_o Q \sqrt{\frac{(1+A)^2 \left[1 - \left(\frac{\omega}{\omega_o} \right)^2 \right]^2 + \frac{1}{Q^2} \left(\frac{\omega}{\omega_o} - \frac{\omega_o}{\omega} \frac{A}{1+A} \right)^2}{1 + \left[Q \frac{\omega}{\omega_o} (1+A) \right]^2}} \quad (18.34)$$

where $A = C_2/C_1$ and $C = C_1 C_2 / (C_1 + C_2)$ such that $\omega_o = 1/\sqrt{LC} = f_o/2\pi$, $Z_o = \sqrt{L/C}$, and $Q = R/Z_o > 1$.

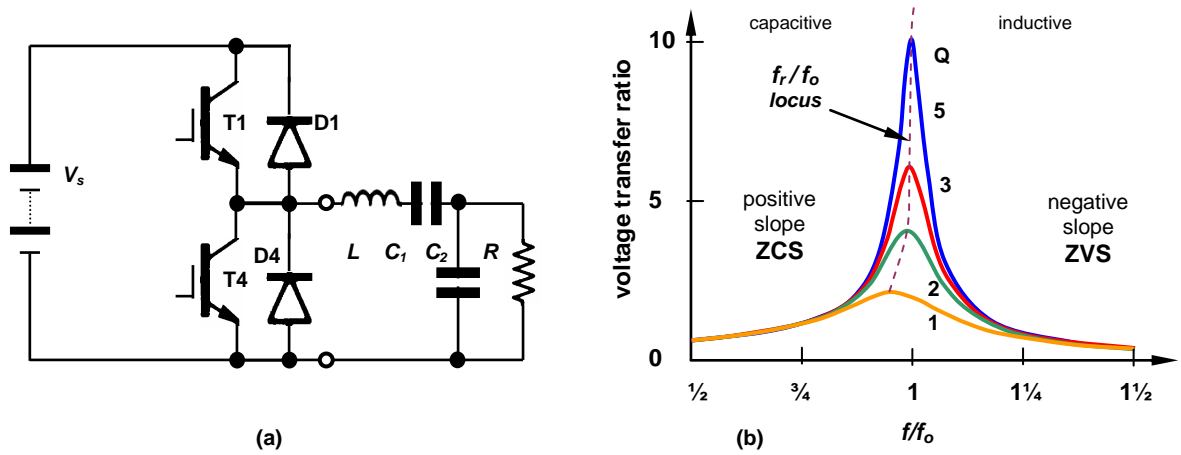

Figure 18.8. Series-parallel resonant voltage source converter: (a) circuit and (b) voltage transfer function, when $C_1=C_2$, that is, $A=C_2/C_1=1$

At resonance, with a large Q

$$Z(\omega_o) = \frac{Z_o}{(1+A)\sqrt{1+Q^2(1+A)^2}} \approx \frac{Z_o^2}{R(1+A)^2} \text{ for } Q(1+A)^2 \gg 1 \quad (18.35)$$

As with the parallel resonant inverter case, series-parallel resonance is load resistance R dependant:

$$\frac{f_r}{f_o} = \sqrt{\frac{Q^2(1+A)^2 - 1 + \sqrt{[Q^2(1+A)^2 - 1]^2 + 4Q^2A(1+A)}}{2Q^2(1+A)^2}} \quad (18.36)$$

When the bridge voltage excitation frequency is less than the circuit resonant frequency, $f < f_r$, the resonant circuit appears capacitive, and inductive if $f > f_r$.

The voltage gain magnitude transfer function, shown in figure 18.8b, is

$$v_R(\omega) = V_R e^{j\phi} = V_i \frac{1}{\sqrt{(1+A)^2 \left[1 - \left(\frac{\omega}{\omega_o}\right)^2\right]^2 + \frac{1}{Q^2} \left(\frac{\omega}{\omega_o} - \frac{\omega_o}{\omega} \frac{A}{1+A}\right)^2}}, \quad \phi = -\tan^{-1} \frac{1}{Q} \frac{\left(\frac{\omega}{\omega_o} - \frac{\omega_o}{\omega} \frac{A}{1+A}\right)}{\left[1 - \left(\frac{\omega}{\omega_o}\right)^2\right]} \quad (18.37)$$

The output voltage can be in excess of the input voltage magnitude.

The inverter is not safe under short-circuit and the open-circuit conditions. At $R = 0$, the capacitor C_2 is shorted-circuited and the resonant circuit consists of L and C_1 . If the switching frequency f is equal to the resonant frequency of this circuit $f_{r1} = 1/2\pi\sqrt{LC_1}$, the magnitude of the current through the switches and the L - C_1 resonant circuit is limited only by low switch resistance and the reactive components. This current may become excessive and destroy the circuit. If f is remote from f_{r1} , the current amplitude is limited by the reactance of the resonant circuit. Because $f_{r1} < f_o$, the inverter is safe for switching frequencies above f_o . At $R = \infty$, the resonant circuit consists of L and the series combination of C_1 and C_2 . Consequently, its resonant frequency is equal to f_o and the inverter is not safe at or close to this frequency, as with the series resonant inverter under light loads.

Summary of voltage source resonant inverters

The maximum voltage across the switches in voltage-source inverters (both half-bridge and full-bridge), when freewheel diodes are incorporated, is equal to the dc input voltage V_s .

- Inverter operation above the resonant frequency f_r is preferred. Such operation results in an inductive load seen by the bridge switches. The switches turn on at zero voltage, thereby reducing the turn-on switching loss, Miller's effect is absent, the switch input capacitance is low, the switch drive-power requirement is low, and turn-on speed is fast. However, switch turn-off is hard switched. The anti-parallel diodes turn off with a low di/dt and without diode recovery voltage snap.
- During operation below resonance, the anti-parallel fast recovery diodes turn off with a high di/dt and generate reverse recovery current spikes. These spikes are present in the switch current at both turn-on and turn-off and stress the switches. For operation below resonance, the switches are turned on at the supply voltage V_s and the switch output capacitance is discharged into a low switch on-resistance, producing a high turn-on switching loss.

The resonant frequency $f_r = f_o$ is constant in the series resonant inverter but f_r depends on the load R in the parallel and series-parallel resonant inverters.

The series resonant inverter can operate safely with an open circuit output, although the output voltage cannot be regulated. It is, however, exposed to excessive currents, $>V_s / Z_o$, which builds up with successive operational cycles, if the output is short-circuited at the operating frequency f close to the resonant frequency $f = f_o$. Any output short circuit protection can exploit the time (number of cycles) it takes for the current build up. The parallel resonant inverter output is protected by the impedance of the inductor from a short circuit output at any switching frequency. Large output currents occur when the output is open-circuited at a switching frequency close to the corner frequency f_o . A short circuit output series circuit behaves the same as an open circuit in the parallel circuit case. Series-parallel resonant inverter operation is not safe with an open-circuited output at frequencies close to the corner frequency f_o and with a short-circuited output at frequencies close to the resonant frequency f_r .

The output voltage of resonant inverters is regulated by changing the switching frequency. However, the required frequency changes in the series resonant inverter are large for no-load or light-load conditions. The series resonant inverter output voltage can be controlled by varying the duty cycle of the square-wave excitation, whilst operating at the resonance frequency. The parallel resonant inverter exhibits good light-load regulation, by operating above resonance. The output voltage at resonance is a function of load, thus can rise to high voltages at no load, if the operating frequency is not increased. It has, however, a low light-load efficiency due to a relatively constant current through the resonant circuit. The series-parallel resonant inverter combines the advantages, and eliminates the weaknesses, of the series and parallel resonant inverter topologies at the expense of an additional resonant capacitor. Alleviated are the poor light load regulation of the series resonant converter and the circulating current independent of load of the parallel resonant inverter.

In the series resonant converter, the series capacitor tends to act as a dc blocking capacitor, facilitating H-bridge operation, prevent core saturation when the load is magnetically coupled. Also the current in the semiconductors decreases as the load decreases, which helps maintain the efficiency at light loads. The input voltage of the resonant circuit in the switched mode full-bridge inverters is a square wave with the voltage levels $\pm V_s$. The peak-to-peak voltage across the resonant circuit in the full-bridge inverter is twice that in the half-bridge inverter. Therefore, the output voltage of the full-bridge inverter is also twice as high and the output power is four times higher than that from the half-bridge inverter at the same operating conditions (load, input voltage, and switching frequency).

18.6 Parallel-resonant current-source inverters

Parallel resonant circuits use a current source inverter (class D, parallel) as considered in 18.2.1 and shown in figure 18.2 parts c and d. If the load Q is high, then resonance need only be re-enforced every second half-cycle, thereby simplifying converter and control requirements. A common feature of parallel resonant circuits fed from a current source, is that commutation of the switches involves overlap where the output of the current source can be briefly shorted.

18.6.1 – Parallel-resonant current-source inverter – single inverter leg – figure 18.2c

Figure 18.2c shows a single-leg half-bridge converter for high Q parallel load circuits. Energy is provided from the constant current source every second half cycle by turning on switch T1. When T1 is turned on (and T3 is subsequently turned off) the voltage across the L - C - R circuit resonates from zero to a maximum and back to zero volts. The energy in the inductor reaches a maximum at each zero voltage instant. T3 is turned on (at zero volts) to divert current from T1, which is then turned off with zero terminal voltage. The energy in the load inductor resonates within the load circuit, with the load in an open circuit state, since T1 is off. The sequence continues when the load voltage resonates back to zero as shown in figure 18.1b.

The parallel circuit steady-state voltage at resonance for the single-leg half-bridge can be approximated by assuming $\omega_o \approx \omega$, such that in equation (18.8) $v_o = 0$:

$$v(\omega t) = \frac{1}{1 - e^{-\frac{\alpha\pi}{\omega}}} \times \frac{I_s}{\omega C} \times e^{-\alpha t} \times \sin \omega t \quad 0 \leq \omega t \leq \pi \quad (18.38)$$

which is valid for both the $+I_s$ loop and open circuit load modes of cycle operation, provided the time reference is moved to the beginning of each half-cycle.

In steady-state the successive inductor current absolute maxima are

$$\hat{I}_L = I_s \frac{1}{1 - e^{-\alpha\pi/\omega}} \quad \text{and} \quad \check{I}_L = I_s \frac{-e^{-\alpha\pi/\omega}}{1 - e^{-\alpha\pi/\omega}} \quad (18.39)$$

The energy transferred to the load R , per half sine cycle (per voltage pulse) is

$$W = \int_0^{\pi/\omega} v^2/R dt = \int_0^{\pi/\omega} \left(\frac{1}{1 - e^{-\frac{\alpha\pi}{\omega}}} \times \frac{I_s}{\omega C} \times e^{-\alpha t} \times \sin \omega t \right)^2 / R dt \quad (18.40)$$

$$= 1/2 L I_s^2 \coth \left(\frac{\alpha\pi}{2\omega} \right)$$

To drive a parallel circuit from a voltage source inverter leg the resonant circuit inductance is series connected to the parallel R - C circuit. The input impedance of the series plus parallel circuit is

$$Z_p = Z e^{j\varphi} = R \left(\frac{1 - \left(\frac{\omega}{\omega_o} \right)^2 + j \frac{1}{Q_p} \frac{\omega}{\omega_o}}{1 + j Q_p \frac{\omega}{\omega_o}} \right) \quad (18.41)$$

$$\text{where } \varphi = \tan^{-1} \left[Q_p \frac{\omega}{\omega_o} \left(\left(\frac{\omega}{\omega_o} \right)^2 - \frac{1}{Q_p^2} - 1 \right) \right]$$

For a voltage source inverter leg, from the series plus parallel ac circuit, the voltage across the resistor, v_R , at a given frequency, ω , is given by

$$v_R(\omega) = V e^{j\varphi} = V_i \frac{\frac{R}{j\omega C}}{R + \frac{1}{j\omega C}} = V_i \frac{1}{j\omega L + \frac{j\omega C}{R + \frac{1}{j\omega C}}} = V_i \frac{1}{1 - \left(\frac{\omega}{\omega_o} \right)^2 + j \frac{1}{Q_p} \frac{\omega}{\omega_o}} \quad (18.42)$$

The magnitude of the resistor voltage is therefore

$$v_R(\omega) = V_i \frac{1}{\sqrt{\left[1 - \left(\frac{\omega}{\omega_o} \right)^2 \right]^2 + \frac{1}{Q_p^2} \left(\frac{\omega}{\omega_o} \right)^2}} \quad (18.43)$$

$$\text{where } \varphi = -\tan^{-1} \frac{\frac{1}{Q_p} \frac{\omega}{\omega_o}}{1 - \left(\frac{\omega}{\omega_o} \right)^2}$$

The maximum resistor voltage is $Q_p / \sqrt{1 - 1/4Q_p^2}$ at $f = f_o \sqrt{1 - 1/2Q_p^2}$. The effective input voltage V_i is $2V_s/\pi$.

18.6.2 – Parallel-resonant current-source inverter – H-bridge current-source inverter–figure 18.2d

If the load Q is low, or maximum energy transfer to the load is required, the full bridge converter shown in figure 18.1d is used.

Operation involves T1 and T2 directing the constant source current to the load and when the load voltage falls to zero, T3 and T4 are turned on (and T1 and T2 are then turned off). Overlapping the switching sequence ensures a path always exists for the source current. At the next half sinusoidal cycle voltage zero, T1 and T2 are turned on and shortly after, T3 and T4 are turned off.

The parallel circuit steady-state voltage for the symmetrical H-bridge can be approximated by assuming $\omega_o \approx \omega$, such that in equation (18.8) $v_o = 0$:

$$v(\omega t) = \frac{2}{1 - e^{-\frac{\alpha\pi}{\omega}}} \times \frac{I_s}{\omega C} \times e^{-\alpha t} \times \sin \omega t \quad 0 \leq \omega t \leq \pi \quad (18.44)$$

which is valid for both the $+ I_s$ loops of cycle operation, provided the time reference is moved to the beginning of each half-cycle.

In steady-state the successive inductor current absolute maxima are

$$\hat{I}_L = I_s \frac{1 + e^{-\alpha\pi/\omega}}{1 - e^{-\alpha\pi/\omega}} = I_s \times \coth(\alpha\pi/2\omega) = -\hat{I}_L \quad (18.45)$$

The energy transferred to the load R , per half sine cycle (per voltage pulse) is

$$W = \int_0^{\pi/\omega} V^2/R \, dt = \int_0^{\pi/\omega} \left(\frac{2}{1 - e^{-\frac{\alpha\pi}{\omega}}} \times \frac{I_s}{\omega C} \times e^{-\alpha t} \times \sin \omega t \right)^2 / R \, dt$$

$$= 2LI_s^2 \coth\left(\frac{\alpha\pi}{2\omega}\right)$$

As with a series resonant circuit, the full bridge delivers four times more power to the load than the single-leg half-bridge circuit. Similarly, the load power and power factor can be controlled by operating above or below the resonant frequency, by delaying or advancing the appropriate switching instances. In the case of a voltage source, the expressions for the voltage across the load resistor are the same as equations (18.41) to (18.43), except the input voltage V_i is doubled, from $2V_s/\pi$ to $4V_s/\pi$.

Example 18.1: Single-leg half-bridge with a series L-C-R load

A single-leg half-bridge inverter as shown in the figure 18.2a, with the dc rail L-C decoupling shown in figure 18.9, supplies a 1Ω resistance load with series inductance $100\mu\text{H}$ from a 340V dc source. If the bridge is to operating at a resonant frequency of 10kHz , determine:

- the necessary series C for resonance at 10kHz and the resultant Q
- the peak load current, its steady-state time domain solution, and peak capacitor voltages
- the bridge rms voltage and fundamental voltage across the series L-C-R load
- the power delivered to the load and the frequency when half power is delivered to the load. What is the switching advance/delay time?
- the peak blocking voltage of each semiconductor type (and for the case when the freewheel diodes are not employed)
- the average, rms, and peak current in the switches and diodes
- the resonant capacitor specification
- the dc supply current and the dc link capacitor rms current
- summarise conditions if the load is supplied from an H-bridge and also calculate the load power supplied at the third harmonic frequency, $3\omega_o$.

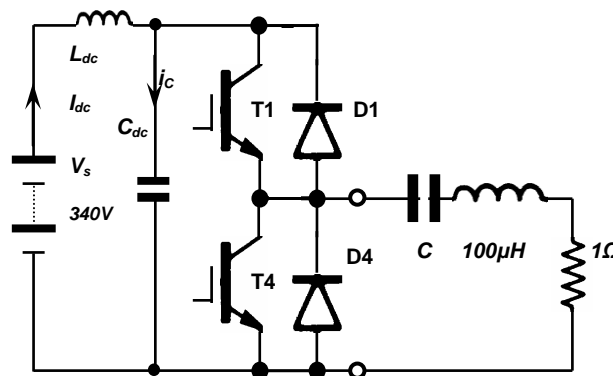

Figure 18.9. Single-leg half-bridge series-resonance circuit.

Solution

- From $\omega_o = 2\pi f_o = 1/\sqrt{LC}$ the necessary capacitance for resonance at 10kHz with $100\mu\text{H}$ is

$$C = \frac{1}{(2 \times \pi \times 10\text{kHz})^2 \times 100\mu\text{H}} = 2.5\mu\text{F}$$

The circuit quality factor Q is given by

$$Q = \frac{Z_o}{R} = \sqrt{\frac{L}{C}} / R = \sqrt{\frac{100\mu\text{H}}{2.5\mu\text{F}}} / 1\Omega = 6.3$$

Therefore

$$\alpha = 5 \times 10^3 \, \Omega/\text{H} \quad \omega = 62.6 \, \text{krad/s} \, (9.968 \, \text{kHz}) \quad Z_o = 6.3 \, \Omega$$

$$\xi = 0.079 \quad BW_s = 9.97 \, \text{krad/s} \, (1.587\text{kHz})$$

- ii. The steady-state current is given by equation (18.15)

$$i(\omega t) = \frac{1}{1 - e^{-\frac{\alpha\pi}{\omega}}} \times \frac{V_s}{\omega L} \times e^{-\alpha t} \times \sin \omega t$$

$$= 245.5 \times e^{-5000t} \times \sin(2\pi 10\text{kHz} \times t)$$

Since the Q is high (6.3), a reasonably accurate estimate of the peak current results if the current expression is evaluated at $\sin(\frac{1}{2}\pi)$, that is $t = 25\mu\text{s}$, which yields $\hat{i} = 216.7\text{A}$. The rms load current is $216.7\text{A}/\sqrt{2} = 153.2\text{A}$ rms.

From equation (18.16) the maximum capacitor voltage extremes are

$$\hat{V}_c = V_s \frac{1}{1 - e^{-\alpha\pi/\omega}} \quad \text{and} \quad \check{V}_c = V_s \frac{-e^{-\alpha\pi/\omega}}{1 - e^{-\alpha\pi/\omega}}$$

$$= \frac{340\text{V}}{1 - e^{-0.25}} \quad = -\frac{340\text{V}e^{-0.25}}{1 - e^{-0.25}}$$

$$= 1537\text{V} \quad = -1197\text{V}$$

- iii. The bridge output voltage is a square wave of magnitude 340V and 0V, with a 50% duty cycle. The rms output voltage is therefore $340/\sqrt{2} = 240.4\text{V}$.

Since the load is at resonance, the current is in phase with the fundamental of the bridge output voltage.

The fundamental voltage magnitude is given by

$$b_1 = \frac{1}{\pi} \int_0^\pi V_s \sin \omega t = \frac{2V_s}{\pi} = 216.5\text{V peak}$$

$$\equiv \frac{\sqrt{2}V_s}{\pi} = 153\text{V rms}$$

The rms load current results because of the fundamental voltage, that is, the peak sine current is $216.5\text{V}/1\Omega = 216.5\text{A}$ peak or $153\text{V}/1\Omega = 153\text{A}$ rms. This agrees with the current values calculated in part b.

- iv. The power delivered to the load is given by

$$P = I_{rms}^2 R = I_{b1}^2 R$$

$$= 153\text{A}^2 \times 1\Omega = 23.41\text{kW}$$

Substitution into equation (18.18) gives 23.15kW at a pulse rate of $2 \times 10\text{kHz}$. Alternately

$$P = V_s \times \bar{I} = V_s \times 0.45 \times I_{rms}$$

$$= 340\text{V} \times 0.45 \times 153\text{A} = 23.42\text{kW}$$

The half-power frequencies are when the reactive voltage magnitude equals the resistive voltage magnitude.

$$f_c^u = f_o \pm \frac{R}{4\pi L}$$

$$= 10\text{kHz} \pm 796\text{Hz}$$

Thus at 9204 Hz and 10796 Hz the voltage across the resistive part of the load is reduced to $1/\sqrt{2}$ of the inverter output voltage, since the voltage vectors are perpendicular. The power (proportional to voltage squared) is therefore halved (11.71kW) at the half-power frequencies.

Operating above resonance, $f > f_o$ produces an inductive load and this is achieved by turning T1 and T4 off prematurely. Zero current turn-on occurs, but hard switching results at turn-off. To operate at the 10796Hz (92.6 μs) upper half-power frequency the period has to be reduced from 100 μs (10kHz) to 92.6 μs . The period of each half cycle has to be reduced by $\frac{1}{2} \times (100\mu\text{s} - 92.6\mu\text{s}) = 3.7\mu\text{s}$

Operating below resonance, $f < f_o$ produces a capacitive load and this is achieved by turning T1 and T4 on late. Zero current turn-off occurs, but hard switching results at turn-on. By delaying turn-on of each switch by $\frac{1}{2} \times (109\mu\text{s} - 100\mu\text{s})$, 4.5 μs , the effective oscillation frequency will be decreased to the lower half-power frequency, 9204Hz.

- v. The bridge diodes, which do not conduct at resonance, clamp switch and diode maximum supporting voltages to the rail voltage, 340V dc.

Note that if clamping diodes were not employed the device maximum off-state voltages would occur during switch change over, when one switch has just been turned off, and just before the on-going switch is turned on. The load current is zero, so the load terminal voltage is the capacitor voltage.

Switch T1 would need to support

a forward voltage of $V_s - \hat{v} = 340V + 1197V = 1537V = \hat{v}$ and
 a reverse voltage of $\hat{v} - V_s = 1537V - 340V = 1197V = -\hat{v}$, while

Switch T4 supports

a forward voltage of $\hat{v} = 1537V$ and
 a reverse voltage of $-\hat{v} = 1197V$.

Thyristor family devices must be used, or devices with a series connected diode, which will increase the converter on-state losses.

vi. At resonance the two freewheel diodes do not conduct.

The rms load current is 153.2 A at 10 kHz, where switch T1 conducts half the cycle and T4 conducts the other half which is the opposite polarity of the cycle. Each switch therefore has an rms current rating of $153.2/\sqrt{2} = 108.3A$ rms.

Since both switches conduct the same current shape, each has an average current rating of a half-wave rectified sine of magnitude 216.5A, that is

$$\begin{aligned}\bar{I}_{T1} &= \frac{1}{2\pi} \int_0^\pi 216.5 \sin \omega t \, dt = \frac{1}{\pi} \times 216.5A \\ &= 0.45 \times 216.5 / \sqrt{2} = 68.9A\end{aligned}$$

By Kirchhoff's current law, this current value for T1 is also equal to the average dc input current from the supply V_s .

vii. The 2.5 μ F capacitor has a bipolar voltage and current requirement of $\pm 1537V$ and ± 216.7 A. The rms ratings are therefore $\approx 1087V$ rms and 153A rms. A metallised polypropylene capacitor capable of 10kHz ac operation, with a maximum dv/dt rating of approximately $\frac{1}{2} \times (1537 + 1197) \times \omega$, that is 85.6V/ μ s, is required.

viii. The dc supply current is the average value of the half-wave rectified sinusoidal load current, which is the average current in T1. That is

$$\begin{aligned}I_{dc} &= 0.45 \times 153.1A \text{ rms} \\ &= 68.9A \text{ dc}\end{aligned}$$

The rms current in the dc link capacitor C_{dc} is related to the dc input current and switch T1 rms current (as found in part vi.), by

$$\begin{aligned}I_c &= \sqrt{I_{rms}^2 - I_{dc}^2} \\ &= \sqrt{108.3^2 - 68.9^2} = 83.6A \text{ rms}\end{aligned}$$

ix. For the full H-bridge, the load dependant parameters C , ω_o , ω , α , Q , BW , ξ , and half power points remain unchanged, being independent of bridge type and switching frequency.

From equation (18.22) the steady-state current is double that for the asymmetrical bridge,

$$\begin{aligned}i(\omega t) &= \frac{2}{1 - e^{-\alpha\pi/\omega}} \times \frac{V_s}{\omega L} \times e^{-\alpha t} \times \sin \omega t \\ &= 491 \times e^{-5000t} \times \sin(2\pi 10\text{kHz} \times t)\end{aligned}$$

The peak current is $\hat{i} = 433.4A$.

The rms load current is $433.4A/\sqrt{2} = 306.4A$ rms

From equation (18.23) both the maximum capacitor voltages are

$$\begin{aligned}\hat{V}_c &= V_s \frac{1 + e^{-\alpha\pi/\omega}}{1 - e^{-\alpha\pi/\omega}} = -\hat{V}_c \\ &= 340V \frac{1 + e^{-0.25}}{1 - e^{-0.25}} = 2734V\end{aligned}$$

The power delivered to the load is four times the single-leg half-bridge case and is

$$P = I_{rms}^2 R = 306.4A^2 \times 1\Omega = 93.88kW$$

The average switch current is 194.8A, but the average supply current is four times the single-leg half-bridge case and is 275.5.6A.

For a square wave, the third harmonic voltage is a third the magnitude of the fundamental. From equation (18.27), for operation at the lower half power frequency 9204Hz, (which would result in the largest harmonic component magnitude after L - C filtering attenuation) $f_3 = 27.6\text{kHz}$.

$$\begin{aligned}
 V_R(\omega_3^-) &= \frac{1}{3} \times \frac{4V_s}{\pi} \times \frac{1}{\sqrt{1 + Q^2 \left(\frac{3\omega_3^-}{\omega_o} - \frac{\omega_o}{3\omega_3^-} \right)^2}} \\
 &= \frac{1}{3} \times \frac{4 \times 340V}{\pi} \times \frac{1}{\sqrt{1 + 6.3^2 \left(\frac{3 \times 2\pi 9.204\text{kHz}}{2\pi 10\text{kHz}} - \frac{2\pi 10\text{kHz}}{3 \times 2\pi 9.204\text{kHz}} \right)^2}} \\
 &= \frac{1}{3} \times \frac{4 \times 340V}{\pi} \times \frac{1}{\sqrt{1 + 6.3^2 \left(\frac{3 \times 9.204}{10} - \frac{10}{3 \times 9.204} \right)^2}} \\
 &= 144.3V \times 0.066 = 9.53V
 \end{aligned}$$

The magnitude of the third harmonic current is therefore $9.5V/1\Omega = 9.5A$ or $6.7A$ rms. The load power at this frequency is $6.7V^2/1\Omega = 45.1W$. This is clearly insignificant compared to the fundamental power of $93.88kW$ being delivered to the 1Ω load.

♣

18.7 Single-switch, current source, series resonant inverter

The single switch inverter in figure 18.10 is applicable to high Q load circuits such that the output is essentially sinusoidal, with zero average current. Based on the operating mechanisms, a sinusoidal current implies the switch has a 50% duty cycle. The switch turns on and off at zero volts so switch losses are low, thus the operating frequency can be high. The input inductor L_{large} in conjunction with the input voltage source, during steady state operation, act as a current source input, I_s , for the resonant circuit, such that $V_s I_s$ is equal to the power delivered to the load R .

When the switch T1 is turned on, with zero terminal voltage, it conducts both the constant current I_s and the current i_o resonating in the output circuit, as shown in the circuit waveforms in figure 18.10. The resonating load current builds up. The switch T1, which is in parallel with C_s , is turned off. Current from the switch is diverted to C_s which charges from an initial voltage of zero. C_s thus forms a turn-off snubber in parallel with T1. The charge on C_s eventually resonates back to zero at which instant the switch is turned on, again, with zero turn-on loss.

The resonant frequency is $\omega_o = 1/\sqrt{L_o C_o}$ and because of the high Q , a small change in the switching frequency significantly decreases the output current, hence output voltage.

As with any current source inverter, the peak switch voltage is in excess of V_s . Since the current is sinusoidal, the average load voltage and inductor voltage are zero. Therefore the average voltage across C_o and C_s is the supply voltage V_s . The peak switch voltage can be estimated to be in excess of $V_s/0.45$ which is based on a half-wave rectified average sinusoidal voltage.

If the load conditions change and the switch duty cycle is varied from $\delta = \frac{1}{2}$, circuit voltages increase and capacitor C_s voltage discharges before the circuit current reaches zero. The capacitor and switch are bypassed with current flowing through the diode D1. This diode prevents the switch from experiencing a negative voltage and the capacitor C_s from charging negatively.

Although such resonant converters offer features such as low switching losses and low radiated EMI, optimal control and performance are difficult to maintain and high circuit voltages occur at low duty cycles.

In contrast to the single-switch resonant converter in figure 18.10, the resonant current sourced converter in figure 18.2c employs two switches, which have series diodes for reverse voltage blocking. The benefit of two switches (which are complementary in switching action), is better output control.

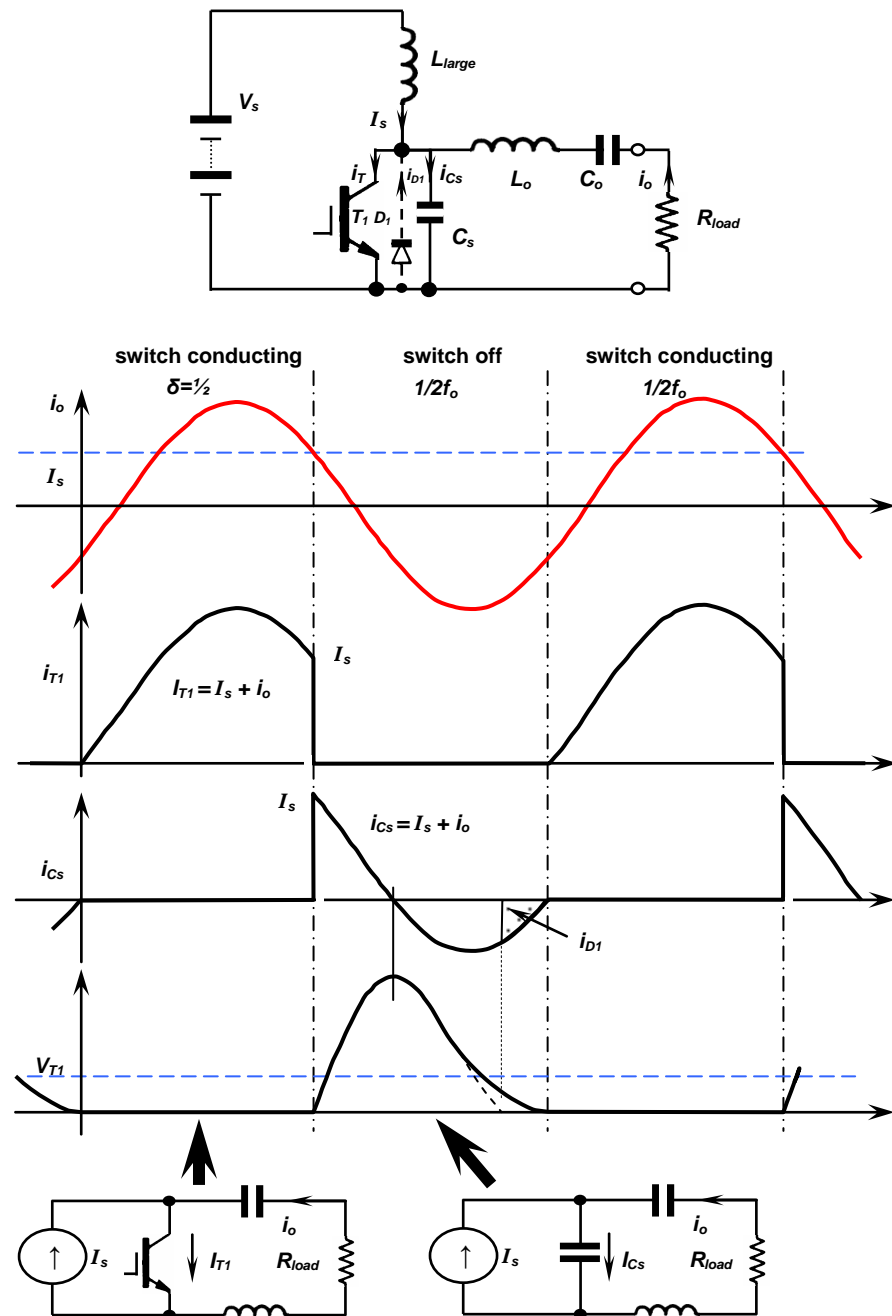

Figure 18.10. Single-switch, current-source series resonant converter circuit and waveforms.

Reading list

Hart, D.W., *Introduction to Power Electronics*,
Prentice-Hall, Inc, 1994.

Mohan, N., *Power Electronics*, 3rd Edition,
Wiley International, 2003.

Problems

Blank