

CHAPTER 16

DC Choppers

A *dc chopper* is a dc-to-dc voltage converter. It is a static switching electrical appliance that in one electrical conversion, changes an input fixed (normally) dc voltage to an adjustable dc output voltage without inductive or capacitive intermediate energy storage. The name *chopper* is connected with the fact that the output voltage is a 'chopped up' quasi-rectangular version of the input dc voltage.

In chapters 13 and 14, thyristor devices were used in conjunction with an ac supply that forces thyristor turn-off at ac supply current reversal. This form of thyristor natural commutation, which is illustrated in figure 16.1a, is termed *line commutation* or *source commutation*.

When a dc source is used with a switching circuit, energy source facilitated switch commutation is clearly not possible. If the load is an *R-C* or *L-C* circuit as illustrated in figure 16.1b, the load current falls to zero whence the switch in series with the dc supply turns off. Such a natural turn-off process is termed *load commutation*.

If the supply is dc and the load current has no natural zero current periods, such as with the *R-L* load, dc chopper circuit shown in figure 16.1c, the load current can only be commutated using a self-commutating switch, such as a GTO thyristor, GCT, IGBT or MOSFET. An SCR is not suitable since once the device is latched on in this dc supply application, it remains on.

The dc chopper in figure 16.1c is the simplest of the five dc choppers to be considered in this chapter. This single-ended, grounded-load, dc chopper will be extensively analysed. See example 16.3.

16.1 DC chopper variations

There are five types of dc choppers, of which four are a subset of the fifth - the flexible but basic, four-quadrant H-bridge chopper shown in the centre of figure 16.2. Notice that the circuits in figure 16.2 are highlighted so that the derivation of each dc chopper from the fundamental H-bridge four-quadrant, dc chopper can be seen. Each chopper can be categorized depending on which output I_o - V_o quadrant or quadrants it can operate in, as shown in figure 16.2. The five different choppers in figure 16.2 are classified according to their output I_o - V_o capabilities as follows:

| | | | |
|-----------------------|--------------------|---------------------|---|
| (a) First quadrant - | I | $+V_o$ $+I_o$ | using switch/diode T_1 D_1 |
| (b) Second quadrant - | II | $+V_o$ $-I_o$ | using switch/diode T_2 D_2 |
| (c) Two quadrant - | I and II | $+V_o$ $\pm I_o$ | using switches/diodes T_1 D_1 T_2 D_2 |
| (d) Two quadrant - | I and IV | $\pm V_o$ $+I_o$ | using switches/diodes T_1 D_1 T_4 D_4 |
| (e) Four quadrant - | I, II, III, and IV | $\pm V_o$ $\pm I_o$ | using switches/diodes T_{1-4} D_{1-4} |

In the five choppers in figure 16.2, the numerical subscript of the active switches and diodes specify in which quadrants operation is possible. For example, the chopper in figure 16.2d uses switches T_1 and T_3 , (plus diodes D_1 and D_3) so can only operate in the first ($+I_o, +V_o$) and third ($-I_o, -V_o$) quadrants.

The **first-quadrant chopper, I**, ($+I_o, +V_o$), in figure 16.2a (and figure 16.1c) can only produce a positive voltage across the load since the freewheel diode D_1 prevents a negative output voltage. Also, the chopper can only deliver current from the dc source to the load through the unidirectional switch T_1 . It is therefore a single quadrant chopper and only operates in the first quadrant ($+I_o, +V_o$), where $V_o \leq V_s$.

The **second-quadrant chopper, II**, ($-I_o, +V_o$), in figure 16.2b is a voltage boost circuit and current flows from the load to the supply, V_s . The switch T_2 is turned on to build-up the inductive load current. Then when the switch is turned off current is forced to flow through diode D_2 into the dc supply. The two current paths (when the switch is on and when it is off) are shown in figure 16.2b.

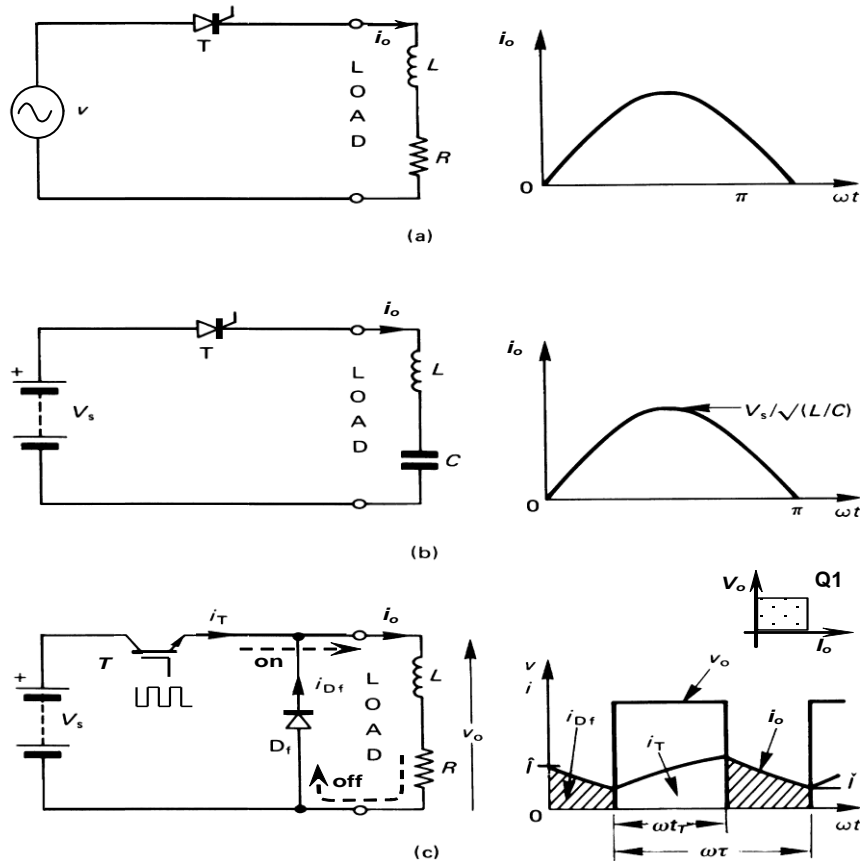

Figure 16.1. Three basic types of switch commutation techniques: (a) source commutation; (b) load commutation; and (c) switch commutation.

In the two-quadrant chopper, **quadrants I and II chopper**, $(\pm I_o, +V_o)$, figure 16.2c, the load voltage is clamped to between 0V and V_s , because of the freewheel diodes D_1 and D_2 . Because this chopper is a combination of the first-quadrant chopper in figure 16.2a and the second-quadrant chopper in figure 16.2b, it combines the characteristics of both. Bidirectional load current is possible but the average output voltage is always positive. Energy can be regenerated into the dc supply V_s due to the load inductive stored energy which maintains current flow from the back emf source ($<V_s$) in the load.

The two-quadrant chopper, **quadrants I and IV chopper**, $(+I_o, \pm V_o)$, figure 16.2d, can produce a positive voltage, negative voltage or zero volts across the load, depending on the duty cycle of the switches and the switching sequence. When both switches are switched simultaneously, an on-state duty cycle of less than 50% ($\delta < 1/2$) results in a negative average load voltage V_o , while $\delta > 1/2$ produces a positive average load voltage. Since V_o is reversible, the power flow direction is reversible, for the shown current i_o . Zero voltage loops are created when one of the two switches is turned off.

The **four-quadrant chopper** in the centre of figure 16.2 combines all the properties of the four subclass choppers. It uses four switches and is capable of producing positive or negative voltages across the load, whilst delivering current to the load in either direction, $(\pm I_o, \pm V_o)$.

The step-up chopper, or boost converter, presented in Chapter 19.4, may be considered a dc chopper variation, which has second quadrant characteristics, while the step-down converter presented in Chapter 19.1 can be considered a first quadrant dc chopper.

16.2 First-quadrant dc chopper, QI

The basic first-quadrant dc chopper circuit reproduced in figure 16.3a can be used to control a dc load such as a dc motor. As such, the dc load has a back-emf component, $E = k\phi\omega$, the magnitude and polarity of which are dependant on the flux ϕ , (field current i_f) and its direction, and the speed ω and its direction. If the R - L load (with time constant $\tau = L/R$) incorporates an opposing back emf, E , then when the switch T_1 is off and the diode D_1 is conducting, the load current can be forced towards zero by the opposing back emf. Therefore two output load current modes (continuous and discontinuous load current) can occur depending on the relative magnitude of the back emf, load time constant, and the switch on-state duty cycle. Continuous load current waveforms are shown in figure 16.3b, while waveforms for discontinuous load current, with periods of zero current, are shown in figure 16.3c.

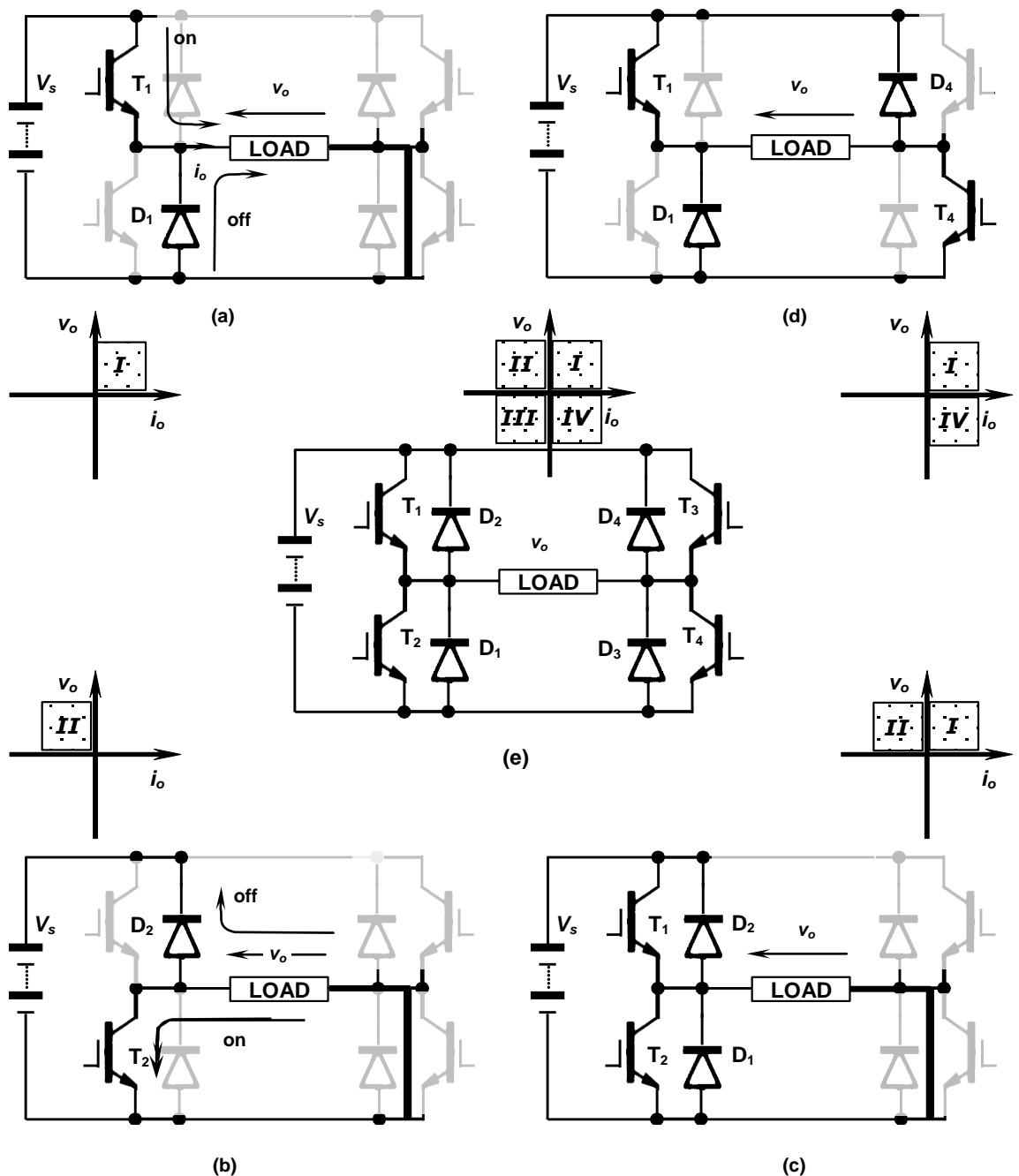

Figure 16.2. *Fundamental four-quadrant chopper (centre) showing derivation of four subclass dc choppers: (a) first-quadrant chopper - I; (b) second-quadrant chopper - II; (c) first and second quadrants chopper - I and II; (d) first and fourth quadrants chopper - I and IV; and (e) four-quadrant chopper.*

In both conduction cases, the average voltage across the load can be controlled by varying the on-to-off time duty cycle of the switch, T_1 . The on-state duty cycle, δ , is normally controlled by using pulse-width modulation, frequency modulation, or a combination of both. When the switch is turned off the inductive load current continues and flows through the load freewheel diode, D_1 , shown in figure 16.3a

The analysis to follow for all the dc choppers, assumes:

- no source impedance
- constant switch duty cycle
- steady state conditions have been reached
- ideal semiconductors and
- no load impedance temperature effects.

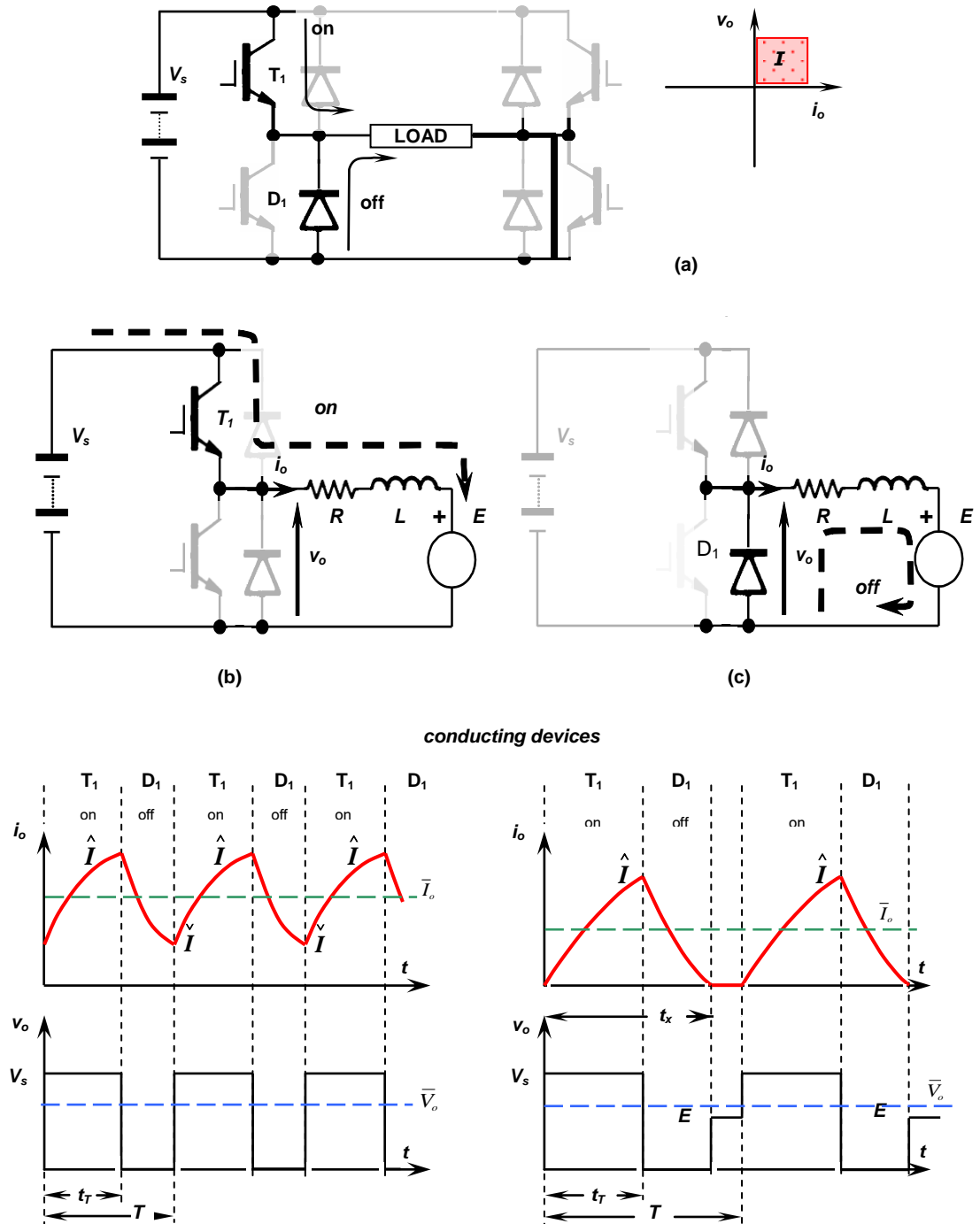

Figure 16.3. First-quadrant dc chopper and two basic modes of chopper output current operation: (a) basic circuit and current paths; (b) continuous load current; and (c) discontinuous load current after $t = t_x$.

16.2.1 Continuous load current

Load waveforms for continuous load current conduction are shown in figure 16.3b.

The output voltage v_o , or load voltage is defined by

$$v_o(t) = \begin{cases} V_s & \text{for } 0 \leq t \leq t_r \\ 0 & \text{for } t_r \leq t \leq T \end{cases} \tag{16.1}$$

The mean load voltage (hence mean load current) is

$$\begin{aligned} \bar{V}_o &= \frac{1}{T} \int_0^{t_r} v_o(t) dt = \frac{1}{T} \int_0^{t_r} V_s dt \\ &= \frac{t_r}{T} V_s = \delta V_s \quad \text{whence} \quad \bar{I}_o = \frac{V_o - E}{R} \end{aligned} \tag{16.2}$$

where the switch on-state duty cycle $\delta = t_r/T$ is defined in figure 16.3b.

The rms load voltage is

$$\begin{aligned} V_{rms} &= \left[\frac{1}{T} \int_0^{t_r} v_o^2(t) dt \right]^{1/2} = \left[\frac{1}{T} \int_0^{t_r} V_s^2 dt \right]^{1/2} \\ &= \sqrt{\frac{t_r}{T}} V_s = \sqrt{\delta} V_s \end{aligned} \quad (16.3)$$

The output ac ripple voltage is

$$\begin{aligned} V_r &= \sqrt{V_{rms}^2 - V_o^2} \\ &= \sqrt{(\sqrt{\delta} V_s)^2 - (\delta V_s)^2} = V_s \sqrt{\delta(1-\delta)} \end{aligned} \quad (16.4)$$

The maximum rms ripple voltage in the output occurs when $\delta = 1/2$ giving an rms ripple voltage of $1/2 V_s$. The output voltage ripple factor is

$$\begin{aligned} RF &= \frac{V_r}{V_o} = \sqrt{\left(\frac{V_{rms}}{V_o} \right)^2 - 1} = \sqrt{FF^2 - 1} \\ &= \sqrt{\left(\frac{\sqrt{\delta} V_s}{\delta V_s} \right)^2 - 1} = \sqrt{\frac{1}{\delta} - 1} = \sqrt{\frac{1-\delta}{\delta}} \end{aligned} \quad (16.5)$$

Thus as the duty cycle $\delta \rightarrow 1$, the ripple factor tends to zero, consistent with the output being dc, that is $V_r = 0$.

Steady-state time domain analysis of first-quadrant chopper - with load back emf and continuous output current

The time domain load current can be derived in a number of ways.

- First, from the Fourier coefficients of the output voltage, the current can be found by dividing by the load impedance at each harmonic frequency.
- Alternatively, the various circuit currents can be found from the time domain load current equations.

i. **Fourier coefficients:** The Fourier coefficients of the load voltage are independent of the circuit and load parameters and are given by

$$\begin{aligned} a_n &= \frac{V_s}{n\pi} \sin 2\pi n\delta \\ b_n &= \frac{V_s}{n\pi} (1 - \cos 2\pi n\delta) \quad \text{for } n \geq 1 \end{aligned} \quad (16.6)$$

Thus the peak magnitude and phase of the n^{th} harmonic are given by

$$\begin{aligned} c_n &= \sqrt{a_n^2 + b_n^2} \\ \phi_n &= \tan^{-1} a_n / b_n \end{aligned}$$

Substituting expressions from equation (16.6) yields

$$\begin{aligned} c_n &= \frac{2V_s}{n\pi} \sin \pi n\delta \\ \phi_n &= \tan^{-1} \frac{\sin 2\pi n\delta}{1 - \cos 2\pi n\delta} = \tan^{-1} \cot \pi n\delta = 1/2\pi - \pi n\delta \end{aligned} \quad (16.7)$$

where

$$v_n = c_n \sin(n\omega t + \phi_n) \quad (16.8)$$

such that

$$\begin{aligned} v_o(t) &= V_o + \sum_{n=1}^{\infty} c_n \sin(n\omega t + \phi_n) \\ &= \delta V_s + \sum_{n=1}^{\infty} \frac{2V_s}{n\pi} \sin \pi n\delta \cos(n(\omega t - \pi\delta)) \end{aligned} \quad (16.9)$$

The load current is given by

$$i_o(t) = \sum_{n=0}^{\infty} i_n = \frac{\bar{V}_o}{R} + \sum_{n=1}^{\infty} \frac{v_n}{Z_n} = \frac{\bar{V}_o}{R} + \sum_{n=1}^{\infty} \frac{c_n \sin(n\omega t - \phi_n)}{Z_n} \quad (16.10)$$

where the load impedance at each harmonic frequency is given by

$$Z_n = \sqrt{R^2 + (n\omega L)^2}$$

ii. **Time domain differential equations:** By solving the appropriate time domain differential equations, the continuous load current shown in figure 16.3b is defined by

During the **switch on-period**, when $v_o(t) = V_s$

$$L \frac{di_o}{dt} + R i_o + E = V_s$$

which yields

$$i_o(t) = \frac{V_s - E}{R} \left(1 - e^{-\frac{t}{\tau}} \right) + \hat{I} e^{-\frac{t}{\tau}} \quad \text{for } 0 \leq t \leq t_T \quad (16.11)$$

During the **switch off-period**, when $v_o(t) = 0$

$$L \frac{di_o}{dt} + R i_o + E = 0$$

which, after shifting the zero time reference to t_T , in figure 16.3a, gives

$$i_o(t) = -\frac{E}{R} \left(1 - e^{-\frac{t}{\tau}} \right) + \hat{I} e^{-\frac{t}{\tau}} \quad \text{for } 0 \leq t \leq T - t_T \quad (16.12)$$

$$\text{where } \hat{I} = \frac{V_s}{R} \frac{1 - e^{-\frac{t_T}{\tau}}}{1 - e^{-\frac{T}{\tau}}} - \frac{E}{R} \quad (A)$$

$$(16.13)$$

$$\text{and } \check{I} = \frac{V_s}{R} \frac{e^{-\frac{t_T}{\tau}} - 1}{e^{-\frac{T}{\tau}} - 1} - \frac{E}{R} \quad (A)$$

The output ripple current, for continuous conduction, is independent of the back emf E and is given by

$$I_{p-p} = \Delta i_o = \hat{I} - \check{I} = \frac{V_s}{R} \frac{(1 - e^{-\frac{t_T}{\tau}})(1 - e^{-\frac{T-t_T}{\tau}})}{1 - e^{-\frac{T}{\tau}}} \quad (16.14)$$

which in terms of the on-state duty cycle, $\delta = t_T/T$, becomes

$$I_{p-p} = \frac{V_s}{R} \frac{(1 - e^{-\delta T})(1 - e^{-(1-\delta)T})}{1 - e^{-T}} \quad (16.15)$$

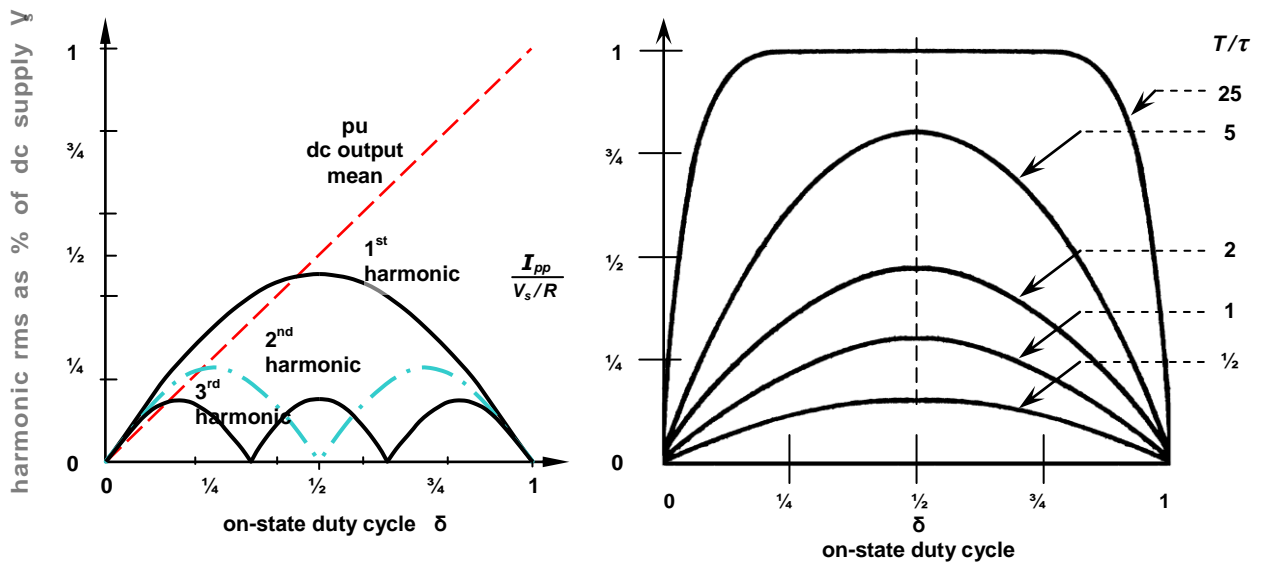

Figure 16.4. Harmonics in the output voltage and ripple current as a function of duty cycle $\delta = t_T/T$ and ratio of cycle period T (switching frequency, $f_s = 1/T$) to load time constant $\tau = L/R$. Valid only for continuous load current conduction.

The peak-to-peak ripple current can be extracted from figure 16.4, which shows a family of curves for equation (16.15), normalised with respect to V_s/R . For a given load time constant $\tau = L/R$, switching frequency $f_s = 1/T$, and switch on-state duty cycle δ , the ripple current can be extracted. This figure shows a number of important features of the ripple current.

- The ripple current I_{pp} reduces to zero at the extremes, as $\delta \rightarrow 0$ and $\delta \rightarrow 1$.
- Differentiation of equation (16.15) reveals that the maximum ripple current \hat{I}_{p-p} occurs at $\delta = 1/2$.
- The longer the load L/R time constant, τ , the lower the output ripple current I_{p-p} .
- The higher the switching frequency, $1/T$, the lower the output ripple.

If the switch conducts continuously ($\delta = 1$), then substitution of $t_T = T$ into equations (16.11) to (16.13) gives a load voltage V_s and a dc load current is

$$i_o = \hat{I} = \check{I} = \frac{V_s - E}{R} \quad \left(= \frac{V_o - E}{R} = \bar{I}_o \right) \quad (\text{A}) \quad (16.16)$$

The mean output current with continuous load current is found by integrating the load current over two consecutive periods, the switch conduction given by equation (16.11) and diode conduction given by equation (16.12), which yields

$$\begin{aligned} \bar{I}_o &= \frac{1}{T} \int_0^T i_o(t) dt = \frac{(\bar{V}_o - E)}{R} \\ &= \frac{(\delta V_s - E)}{R} \end{aligned} \quad (\text{A}) \quad (16.17)$$

The input and output powers are related such that

$$\begin{aligned} P_{in} &= P_{out} \\ P_{in} &= V_s \bar{I}_i = V_s \left(\frac{\delta(V_s - E)}{R} - \frac{\tau}{T} (\hat{I} - \check{I}) \right) \\ P_{out} &= \frac{1}{T} \int_0^T v_o(t) i_o(t) dt \\ &= I_{o,rms}^2 R + E \bar{I}_o = I_{o,rms}^2 R + E \left(\frac{\delta V_s - E}{R} \right) \end{aligned} \quad (16.18)$$

from which the average input current can be evaluated.

Alternatively, the average input current, which is the average switch current, \bar{I}_{switch} , can be derived by integrating the switch current which is given by equation (16.11), that is

$$\begin{aligned} \bar{I}_i &= \bar{I}_{switch} = \frac{1}{T} \int_0^{t_T} i_o(t) dt \\ &= \frac{1}{T} \int_0^{t_T} \left(\frac{V_s - E}{R} \left(1 - e^{-\frac{t}{\tau}} \right) + \check{I} e^{-\frac{t}{\tau}} \right) dt \\ &= \frac{\delta(V_s - E)}{R} - \frac{\tau}{T} (\hat{I} - \check{I}) \end{aligned} \quad (16.19)$$

The term $\hat{I} - \check{I} = I_{p-p}$ is the peak-to-peak ripple current, which is given by equation (16.15). By Kirchhoff's current law, the average diode current \bar{I}_{diode} is the difference between the average output current \bar{I}_o and the average input current, \bar{I}_i , that is

$$\begin{aligned} \bar{I}_{diode} &= \bar{I}_o - \bar{I}_i \\ &= \frac{(\delta V_s - E)}{R} - \frac{\delta(V_s - E)}{R} + \frac{\tau}{T} (\hat{I} - \check{I}) \\ &= \frac{\tau}{T} (\hat{I} - \check{I}) - \frac{E(1 - \delta)}{R} \end{aligned} \quad (16.20)$$

Alternatively, the average diode current can be found by integrating the diode current given in equation (16.12), as follows

$$\begin{aligned} \bar{I}_{diode} &= \frac{1}{T} \int_0^{T-t_T} \left(-\frac{E}{R} \left(1 - e^{-\frac{t}{\tau}} \right) + \hat{I} e^{-\frac{t}{\tau}} \right) dt \\ &= \frac{\tau}{T} (\hat{I} - \check{I}) - \frac{E(1 - \delta)}{R} \end{aligned} \quad (16.21)$$

If E represents motor back emf, then the electromagnetic energy conversion efficiency is given by

$$\eta = \frac{E \bar{I}_o}{P_{in}} = \frac{E \bar{I}_o}{V_s \bar{I}_i} \quad (16.22)$$

The chopper effective (dc) input impedance at the dc source is given by

$$Z_{in} = \frac{V_s}{\bar{I}_i} \quad (16.23)$$

For an R - L load without a back emf, set $E=0$ in the foregoing equations. The discontinuous load current analysis to follow is not valid for an R - L , with $E=0$ load, since the load current never reaches zero, but at best asymptotes towards zero during the off-period of the switch.

16.2.2 Discontinuous load current

With an opposing emf E in the load, the load current can reach zero during the off-time, at a time t_x shown in figure 16.3c. The time t_x can be found by

- deriving an expression for \hat{I} from equation (16.11), setting $t = t_T$,
- this equation is substituted into equation (16.12) which is equated to zero, having substituted for $t = t_x$: yielding

$$t_x = t_T + \tau \ln \left(1 + \frac{V_s - E}{E} \left(1 - e^{-\frac{t_T}{\tau}} \right) \right) \quad (s) \quad (16.24)$$

This equation shows that $t_x > t_T$.

Alternatively, for a given frequency, $1/T$, discontinuous current will occur as the duty cycle is decreased. Rearranging equation (16.13), after setting $\dot{I} = 0$ and extracting the duty cycle $\delta = t_T / T$ yields

$$\delta = \frac{t_T}{T} \leq \frac{\tau}{T} \ln \left[1 + \frac{E}{V_s} \left(e^{\frac{T}{\tau}} - 1 \right) \right] \quad (16.25)$$

Conversely, discontinuous conduction will occur as the frequency decreases for a given switch on-time, according to

$$T = \frac{1}{f} \geq \tau \ln \left[1 + \frac{V_s}{E} \left(e^{\frac{t_T}{\tau}} - 1 \right) \right] \quad (16.26)$$

Figure 16.5 can be used to determine if a particular set of operating conditions involves discontinuous load current.

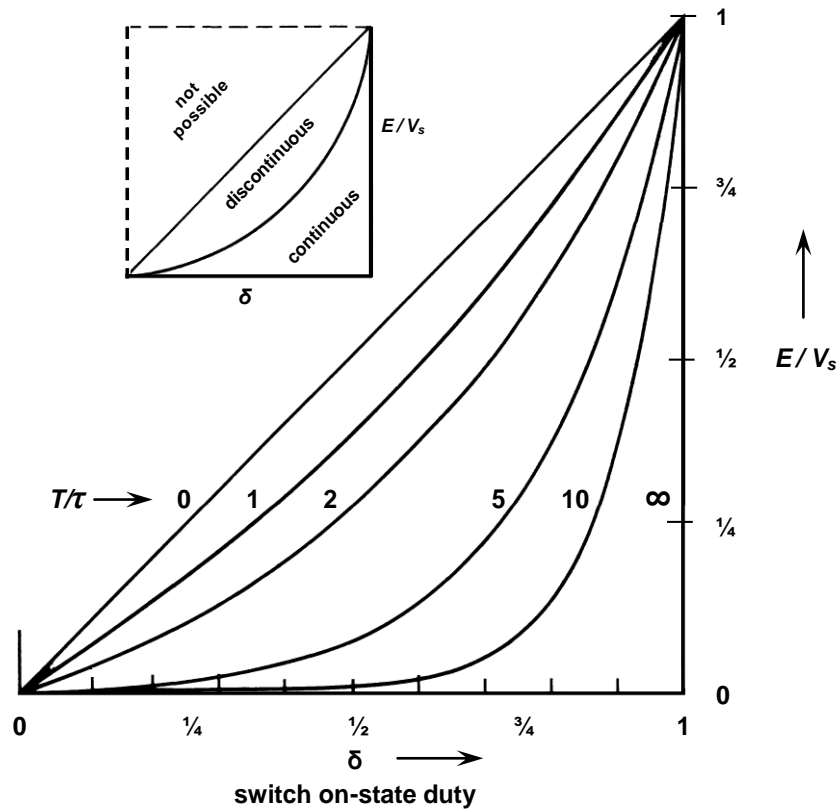

Figure 16.5. Bounds of discontinuous load current with $E > 0$.

The load voltage waveform for discontinuous load current conduction shown in figure 16.3c is defined by

$$v_o(t) = \begin{cases} V_s & \text{for } 0 \leq t \leq t_T \\ 0 & \text{for } t_T \leq t \leq t_x \\ E & \text{for } t_x \leq t \leq T \end{cases} \quad (16.27)$$

If discontinuous load current exists for a period $T - t_x$, from t_x until T , then the mean output voltage is

$$\begin{aligned} \bar{V}_o &= \frac{1}{T} \left(\int_0^{t_T} V_s dt + \int_{t_T}^{t_x} 0 dt + \int_{t_x}^T E dt \right) \quad \left(\text{thence } \bar{I}_o = \bar{V}_o - E/R \right) \\ \bar{V}_o &= \delta V_s + \frac{T - t_x}{T} E \quad (V) \quad \text{for } t_x \geq t_T \end{aligned} \quad (16.28)$$

The rms output voltage with discontinuous load current conduction is given by

$$V_{rms} = \left[\frac{1}{T} \left(\int_0^{t_r} V_s^2 dt + \int_{t_r}^{t_x} 0^2 dt + \int_{t_x}^T E^2 dt \right) \right]^{1/2} \quad (16.29)$$

$$= \sqrt{\delta V_s^2 + \frac{T-t_x}{T} E^2} \quad (\text{V})$$

The ac ripple voltage and ripple factor can be found by substituting equations (16.28) and (16.29) into

$$V_r = \sqrt{V_{rms}^2 - V_o^2} \quad (16.30)$$

and

$$RF = \frac{V_r}{V_o} = \sqrt{\left(\frac{V_{rms}}{V_o} \right)^2 - 1} = \sqrt{FF^2 - 1} \quad (16.31)$$

**Steady-state time domain analysis of first-quadrant chopper
- with load back emf and discontinuous output current**

i. **Fourier coefficients:** The load current can be derived indirectly by using the output voltage Fourier series. The Fourier coefficients of the load voltage are

$$a_n = \frac{V_s}{n\pi} \sin 2\pi n \delta - \frac{E}{n\pi} \sin 2\pi n \frac{t_x}{T} \quad (16.32)$$

$$b_n = \frac{V_s}{n\pi} (1 - \cos 2\pi n \delta) - \frac{E}{n\pi} (1 - \cos 2\pi n \frac{t_x}{T}) \quad n \geq 1$$

which using

$$c_n = \sqrt{a_n^2 + b_n^2}$$

$$\phi_n = \tan^{-1} a_n / b_n$$

give

$$v_o(t) = \bar{V}_o + \sum_{n=1}^{\infty} c_n \sin(n\omega t + \phi_n) \quad (16.33)$$

The appropriate division by $Z_n = \sqrt{R^2 + (n\omega L)^2}$ yields the output current.

ii. **Time domain differential equations:** For discontinuous load current, $\dot{I} = 0$. Substituting this condition into the time domain equations (16.11) to (16.14) yields equations for discontinuous load current, specifically:

During the **switch on-period**, when $v_o(t) = V_s$,

$$i_o(t) = \frac{V_s - E}{R} \left(1 - e^{-\frac{t}{\tau}} \right) \quad \text{for } 0 \leq t \leq t_r \quad (16.34)$$

During the **switch off-period**, when $v_o(t) = 0$, after shifting the zero time reference to t_r ,

$$i_o(t) = -\frac{E}{R} \left(1 - e^{-\frac{t}{\tau}} \right) + \hat{I} e^{-\frac{t}{\tau}} \quad \text{for } 0 \leq t \leq t_x - t_r \quad (16.35)$$

where from equation (16.34), with $t = t_r$,

$$\hat{I} = \frac{V_s - E}{R} \left(1 - e^{-\frac{t_r}{\tau}} \right) \quad (\text{A}) \quad (16.36)$$

After t_x , $v_o(t) = E$ and the load current is zero, that is

$$i_o(t) = 0 \quad \text{for } t_x \leq t \leq T \quad (16.37)$$

The output ripple current, for discontinuous conduction, is dependent of the back emf E and is given by equation (16.36), that is

$$I_{p-p} = \hat{I} = \frac{V_s - E}{R} \left(1 - e^{-\frac{t_r}{\tau}} \right) \quad (16.38)$$

Since $\dot{I} = 0$, the mean output current for discontinuous conduction, is

$$\bar{I}_o = \frac{1}{T} \int_0^{t_x} i_o(t) dt = \frac{1}{T} \left[\int_0^{t_r} \frac{V_s - E}{R} \left(1 - e^{-\frac{t}{\tau}} \right) dt + \int_0^{t_x - t_r} \frac{-E}{R} \left(1 - e^{-\frac{t}{\tau}} \right) + \hat{I} e^{-\frac{t}{\tau}} dt \right]$$

$$= \frac{(\bar{V}_o - E)}{R}$$

$$\bar{I}_o = \frac{\delta V_s + \left(1 - \frac{t_x}{T}\right) E}{R} - \frac{E}{R} = \left(\delta V_s - \frac{t_x}{T} E \right) / R \quad (\text{A}) \quad (16.39)$$

The input and output powers are related such that

$$P_{in} = V_s \bar{I}_i \quad P_{out} = I_{o\text{rms}}^2 R + E \bar{I}_o \quad P_{in} = P_{out} \quad (16.40)$$

from which the average input current can be evaluated.

Alternatively the average input current, which is the switch average current, is given by

$$\begin{aligned} \bar{I}_i = \bar{I}_{switch} &= \frac{1}{T} \int_0^{t_r} i_o(t) dt \\ &= \frac{1}{T} \int_0^{t_r} \frac{V_s - E}{R} \left(1 - e^{-\frac{t}{\tau}}\right) dt \\ &= \frac{V_s - E}{R} \left(\delta - \frac{\tau}{T} \left(1 - e^{-\frac{t_r}{\tau}}\right) \right) = \frac{V_s - E}{R} \delta - \frac{\tau}{T} \hat{I} \end{aligned} \quad (16.41)$$

The average diode current \bar{I}_{diode} is the difference between the average output current \bar{I}_o and the average input current, \bar{I}_i , that is

$$\begin{aligned} \bar{I}_{diode} &= \bar{I}_o - \bar{I}_i \\ &= \frac{\tau}{T} \hat{I} - \frac{E \left(\frac{t_x}{T} - \delta \right)}{R} \end{aligned} \quad (16.42)$$

Alternatively, the average diode current can be found by integrating the diode current given in equation (16.35), as follows

$$\begin{aligned} \bar{I}_{diode} &= \frac{1}{T} \int_0^{t_x - t_r} \left(-\frac{E}{R} \left(1 - e^{-\frac{t}{\tau}}\right) + \hat{I} e^{-\frac{t}{\tau}} \right) dt \\ &= \frac{\tau}{T} \hat{I} - \frac{E \left(\frac{t_x}{T} - \delta \right)}{R} \end{aligned} \quad (16.43)$$

If E represents motor back emf, then electromagnetic energy conversion efficiency is given by

$$\eta = \frac{E \bar{I}_o}{P_{in}} = \frac{E \bar{I}_o}{V_s \bar{I}_i} \quad (16.44)$$

The chopper effective input impedance is given by

$$Z_{in} = \frac{V_s}{\bar{I}_i} \quad (16.45)$$

Example 16.1: DC chopper (first quadrant) with load back emf

A first-quadrant dc-to-dc chopper feeds an inductive load of 10Ω resistance, 50mH inductance, and back emf of 55V dc, from a 340V dc source. If the chopper is operated at 200Hz with a 25% on-state duty cycle, determine, with and without (rotor standstill, $E = 0$) the back emf:

- i. the load average and rms voltages;
- ii. the rms ripple voltage, hence ripple factor;
- iii. the maximum and minimum output current, hence the peak-to-peak output ripple in the current;
- iv. the current in the time domain;
- v. the average load output current, average switch current, and average diode current;
- vi. the input power, hence output power and rms output current;
- vii. effective input impedance, (and electromagnetic efficiency for $E > 0$); and
- viii. sketch the output current and voltage waveforms.

Solution

The main circuit and operating parameters are

- on-state duty cycle $\delta = \frac{1}{4}$
- period $T = 1/f_s = 1/200\text{Hz} = 5\text{ms}$
- on-period of the switch $t_T = 1.25\text{ms}$
- load time constant $\tau = L/R = 0.05\text{mH}/10\Omega = 5\text{ms}$

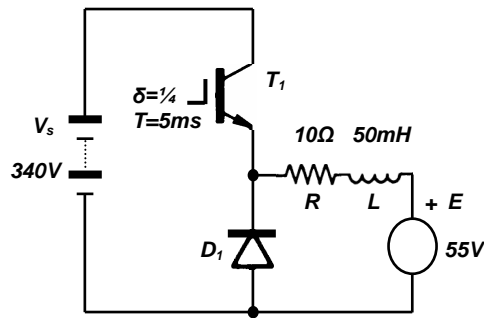

Figure 16.6. Example 16.1.
Circuit diagram.

- i. From equations (16.2) and (16.3), assuming continuous load current, the average and rms output voltages are both independent of the back emf, namely

$$\begin{aligned}\bar{V}_o &= \frac{t_T}{T} V_s = \delta V_s \\ &= \frac{1}{4} \times 340\text{V} = 85\text{V} \\ V_r &= \sqrt{\frac{t_T}{T}} V_s = \sqrt{\delta} V_s \\ &= \sqrt{\frac{1}{4}} \times 340\text{V} = 170\text{V rms}\end{aligned}$$

- ii. The rms ripple voltage hence ripple factor are given by equations (16.4) and (16.5), that is

$$\begin{aligned}V_r &= \sqrt{V_{rms}^2 - V_o^2} = V_s \sqrt{\delta(1-\delta)} \\ &= 340\text{V} \sqrt{\frac{1}{4} \times (1 - \frac{1}{4})} = 147.2\text{V ac}\end{aligned}$$

and

$$\begin{aligned}RF &= \frac{V_r}{V_o} = \sqrt{\frac{1}{\delta} - 1} = \sqrt{FF^2 - 1} \\ &= \sqrt{\frac{1}{\frac{1}{4}} - 1} = \sqrt{3} = 1.732 \quad FF = 2\end{aligned}$$

No back emf, $E = 0$

- iii. From equation (16.13), with $E = 0$, the maximum and minimum currents are

$$\begin{aligned}\hat{I} &= \frac{V_s}{R} \frac{1 - e^{-\frac{t_T}{\tau}}}{1 - e^{-\frac{T}{\tau}}} = \frac{340\text{V}}{10\Omega} \times \frac{1 - e^{-\frac{1.25\text{ms}}{5\text{ms}}}}{1 - e^{-\frac{5\text{ms}}{5\text{ms}}}} = 11.90\text{A} \\ \check{I} &= \frac{V_s}{R} \frac{e^{\frac{t_T}{\tau}} - 1}{e^{\frac{T}{\tau}} - 1} = \frac{340\text{V}}{10\Omega} \times \frac{e^{\frac{1}{4}} - 1}{e^1 - 1} = 5.62\text{A}\end{aligned}$$

The peak-to-peak ripple in the output current is therefore

$$\begin{aligned}I_{p-p} &= \hat{I} - \check{I} \\ &= 11.90\text{A} - 5.62\text{A} = 6.28\text{A}\end{aligned}$$

Alternatively the ripple can be extracted from figure 16.4 using $T/\tau=1$ and $\delta = \frac{1}{4}$.

- iv. From equations (16.11) and (16.12), with $E = 0$, the time domain load current equations are

$$\begin{aligned}i_o &= \frac{V_s}{R} \left(1 - e^{-\frac{t}{\tau}}\right) + \check{I} e^{-\frac{t}{\tau}} \\ i_o(t) &= 34 \times \left(1 - e^{-\frac{t}{5\text{ms}}}\right) + 5.62 \times e^{-\frac{t}{5\text{ms}}} \\ &= 34 - 28.38 \times e^{-\frac{t}{5\text{ms}}} \quad (\text{A}) \quad \text{for } 0 \leq t \leq 1.25\text{ms} \\ i_o &= \hat{I} e^{-\frac{t}{\tau}} \\ i_o(t) &= 11.90 \times e^{-\frac{t}{5\text{ms}}} \quad (\text{A}) \quad \text{for } 0 \leq t \leq 3.75\text{ms}\end{aligned}$$

- v. The average load current from equation (16.17), with $E = 0$, is

$$\bar{I}_o = \bar{V}_o / R = 85\text{V} / 10\Omega = 8.5\text{A}$$

The average switch current, which is the average supply current, is

$$\begin{aligned}\bar{I}_i = \bar{I}_{switch} &= \frac{\delta(V_s - E)}{R} - \frac{\tau}{T}(\hat{I} - \check{I}) \\ &= \frac{1/4 \times (340\text{V} - 0)}{10\Omega} - \frac{5\text{ms}}{5\text{ms}} \times (11.90\text{A} - 5.62\text{A}) = 2.22\text{A}\end{aligned}$$

The average diode current is the difference between the average load current and the average input current, that is

$$\begin{aligned}\bar{I}_{diode} &= \bar{I}_o - \bar{I}_i \\ &= 8.50\text{A} - 2.22\text{A} = 6.28\text{A}\end{aligned}$$

vi. The input power is the dc supply voltage multiplied by the average input current, that is

$$P_{in} = V_s \bar{I}_i = 340\text{V} \times 2.22\text{A} = 754.8\text{W}$$

$$P_{out} = P_{in} = 754.8\text{W}$$

From equation (16.18) the rms load current is given by

$$\begin{aligned}\bar{I}_{o\text{ rms}} &= \sqrt{\frac{P_{out}}{R}} \\ &= \sqrt{\frac{754.8\text{W}}{10\Omega}} = 8.7\text{A rms}\end{aligned}$$

vii. The chopper effective input impedance is

$$\begin{aligned}Z_{in} &= \frac{V_s}{\bar{I}_i} \\ &= \frac{340\text{V}}{2.22\text{A}} = 153.2\ \Omega\end{aligned}$$

Load back emf, $E = 55\text{V}$

i. and ii. The average output voltage (85V), rms output voltage (120V rms), ac ripple voltage (147.2V ac), and ripple factor (1.732) are independent of back emf, provided the load current is continuous. The earlier answers for $E = 0$ are applicable.

iii. From equation (16.13), the maximum and minimum load currents are

$$\begin{aligned}\hat{I} &= \frac{V_s}{R} \frac{1 - e^{-\frac{t}{\tau}}}{1 - e^{-\frac{T}{\tau}}} - \frac{E}{R} = \frac{340\text{V}}{10\Omega} \times \frac{1 - e^{-\frac{1.25\text{ms}}{5\text{ms}}}}{1 - e^{-\frac{5\text{ms}}{5\text{ms}}}} - \frac{55\text{V}}{10\Omega} = 6.40\text{A} \\ \check{I} &= \frac{V_s}{R} \frac{e^{\frac{t}{\tau}} - 1}{e^{\frac{T}{\tau}} - 1} - \frac{E}{R} = \frac{340\text{V}}{10\Omega} \times \frac{e^{1/4} - 1}{e^1 - 1} - \frac{55\text{V}}{10\Omega} = 0.12\text{A}\end{aligned}$$

The peak-to-peak ripple in the output current is therefore

$$\begin{aligned}I_{p-p} &= \hat{I} - \check{I} \\ &= 6.4\text{A} - 0.12\text{A} = 6.28\text{A}\end{aligned}$$

The ripple value is the same as the $E = 0$ case, which is as expected since ripple current is independent of back emf with continuous output current.

Alternatively the ripple can be extracted from figure 16.4 using $T/\tau = 1$ and $\delta = 1/4$.

iv. The time domain load current is defined by

$$\begin{aligned}i_o &= \frac{V_s - E}{R} \left(1 - e^{-\frac{t}{\tau}}\right) + \check{I} e^{-\frac{t}{\tau}} \\ i_o(t) &= 28.5 \times \left(1 - e^{-\frac{t}{5\text{ms}}}\right) + 0.12e^{-\frac{t}{5\text{ms}}} \\ &= 28.5 - 28.38e^{-\frac{t}{5\text{ms}}} \quad (\text{A}) \quad \text{for } 0 \leq t \leq 1.25\text{ms} \\ i_o &= -\frac{E}{R} \left(1 - e^{-\frac{t}{\tau}}\right) + \hat{I} e^{-\frac{t}{\tau}} \\ i_o(t) &= -5.5 \times \left(1 - e^{-\frac{t}{5\text{ms}}}\right) + 6.4e^{-\frac{t}{5\text{ms}}} \\ &= -5.5 + 11.9e^{-\frac{t}{5\text{ms}}} \quad (\text{A}) \quad \text{for } 0 \leq t \leq 3.75\text{ms}\end{aligned}$$

v. The average load current from equation (16.39) is

$$\begin{aligned} \bar{I}_o &= \frac{V_o - E}{R} \\ &= \frac{85V - 55V}{10\Omega} = 3A \end{aligned}$$

The average switch current is the average supply current,

$$\begin{aligned} \bar{I}_i = \bar{I}_{switch} &= \frac{\delta(V_s - E)}{R} - \frac{\tau}{T}(\hat{I} - \check{I}) \\ &= \frac{1/4 \times (340V - 55V)}{10\Omega} - \frac{5ms}{5ms} \times (6.40A - 0.12A) = 0.845A \end{aligned}$$

The average diode current is the difference between the average load current and the average input current, that is

$$\begin{aligned} \bar{I}_{diode} &= \bar{I}_o - \bar{I}_i \\ &= 3A - 0.845A = 2.155A \end{aligned}$$

vi. The input power is the dc supply voltage multiplied by the average input current, that is

$$\begin{aligned} P_{in} &= V_s \bar{I}_i = 340V \times 0.845A = 287.3W \\ P_{out} &= P_{in} = 287.3W \end{aligned}$$

From equation (16.18) the rms load current is given by

$$\begin{aligned} \bar{I}_{rms} &= \sqrt{\frac{P_{out} - E\bar{I}_o}{R}} \\ &= \sqrt{\frac{287.3W - 55V \times 3A}{10\Omega}} = 3.5A \text{ rms} \end{aligned}$$

vii. The chopper effective input impedance is

$$\begin{aligned} Z_{in} &= \frac{V_s}{\bar{I}_i} \\ &= \frac{340V}{0.845A} = 402.4 \Omega \end{aligned}$$

The electromagnetic efficiency is given by equation (16.22), that is

$$\begin{aligned} \eta &= \frac{E\bar{I}_o}{P_{in}} \\ &= \frac{55V \times 3A}{287.3W} = 57.4\% \end{aligned}$$

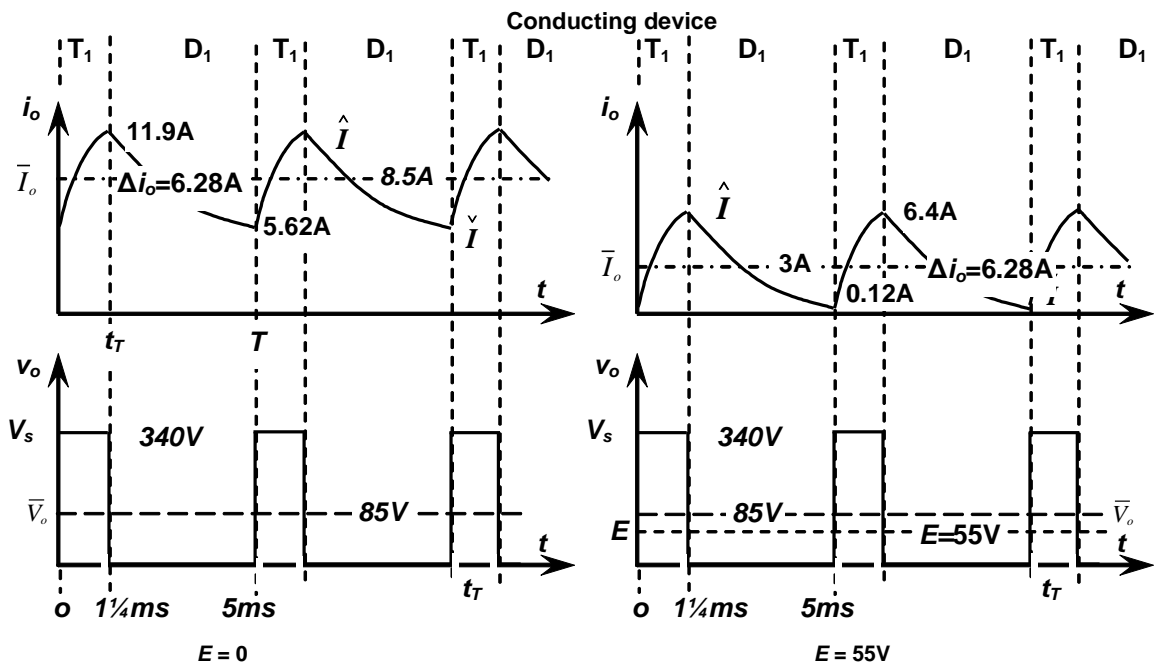

Figure 16.7. Example 16.1. Circuit waveforms.

viii. The output voltage and current waveforms for the first-quadrant chopper, with and without back emf, are shown in figure 16.7.



Example 16.2: *DC chopper with load back emf - verge of discontinuous conduction*

A first-quadrant dc-to-dc chopper feeds an inductive load of 10 Ω resistance, 50mH inductance, and back emf of 55V dc, from a 340V dc voltage source. If the chopper is operated at 200Hz with a 25% on-state duty cycle, determine:

- i. the maximum back emf before discontinuous load current conduction commences with $\delta=1/4$;
- ii. with 55V back emf, what is the minimum duty cycle before discontinuous load current conduction; and
- iii. minimum switching frequency at $E=55V$ and $t_T = 1.25ms$ before discontinuous conduction.

Solution

The main circuit and operating parameters are

- on-state duty cycle $\delta = 1/4$
- period $T = 1/f_s = 1/200\text{Hz} = 5\text{ms}$
- on-period of the switch $t_T = 1.25\text{ms}$
- load time constant $\tau = L/R = 0.05\text{mH}/10\Omega = 5\text{ms}$

First it is necessary to establish whether the given conditions represent continuous or discontinuous load current. The current extinction time t_x for discontinuous conduction is given by equation (16.24), and yields

$$\begin{aligned} t_x &= t_T + \tau \ln \left(1 + \frac{V_s - E}{E} \left(1 - e^{-\frac{t_T}{\tau}} \right) \right) \\ &= 1.25\text{ms} + 5\text{ms} \times \ln \left(1 + \frac{340\text{V} - 55\text{V}}{55\text{V}} \times \left(1 - e^{-\frac{1.25\text{ms}}{5\text{ms}}} \right) \right) = 5.07\text{ms} \end{aligned}$$

Since the cycle period is 5ms, which is less than the necessary time for the current to fall to zero (5.07ms), the load current is continuous. From example 16.1 part iv, with $E = 55V$ the load current falls from 6.4A to near zero (0.12A) at the end of the off-time, thus the chopper is operating near the verge of discontinuous conduction. A small increase in E , decrease in the duty cycle δ , or increase in switching period T , would be expected to result in discontinuous load current.

i. \hat{E}

The necessary back emf can be determined graphically or analytically.

Graphically:

The bounds of continuous and discontinuous load current for a given duty cycle, switching period, and load time constant can be determined from figure 16.5.

Using $\delta = 1/4$, $T/\tau = 1$ with $\tau = 5\text{ms}$, and $T = 5\text{ms}$, figure 16.5 gives $E/V_s = 0.165$. That is, $E = 0.165 \times V_s = 0.165 \times 340\text{V} = 56.2\text{V}$

Analytically:

The chopper is operating too close to the boundary between continuous and discontinuous load current conduction for accurate readings to be obtained from the graphical approach, using figure 16.5. Examination of the expression for minimum current, equation (16.13), gives

$$\hat{I} = \frac{V_s}{R} \frac{e^{\frac{t_T}{\tau}} - 1}{e^{\frac{T}{\tau}} - 1} - \frac{E}{R} = 0$$

Rearranging to give the back emf, E , produces

$$\begin{aligned} E &= V_s \frac{e^{\frac{t_T}{\tau}} - 1}{e^{\frac{T}{\tau}} - 1} \\ &= 340\text{V} \times \frac{e^{\frac{1.25\text{ms}}{5\text{ms}}} - 1}{e^{\frac{5\text{ms}}{5\text{ms}}} - 1} = 56.2\text{V} \end{aligned}$$

That is, if the back emf increases from 55V to 56.2V then at and above that voltage, discontinuous load current commences.

ii. δ

Again, if equation (16.13) is solved for $\dot{I} = 0$ then

$$\dot{I} = \frac{V_s}{R} \frac{e^{\frac{t_T}{\tau}} - 1}{e^{\frac{T}{\tau}} - 1} - \frac{E}{R} = 0$$

Rearranging to isolate t_T gives

$$\begin{aligned} t_T &= \tau \ln \left(1 + \frac{E}{V_s} \left(e^{\frac{T}{\tau}} - 1 \right) \right) \\ &= 5\text{ms} \times \ln \left(1 + \frac{55\text{V}}{340\text{V}} \left(e^{\frac{5\text{ms}}{5\text{ms}}} - 1 \right) \right) \\ &= 1.226\text{ms} \end{aligned}$$

If the switch on-state period is reduced by 0.024ms, from 1.250ms to 1.226ms ($\delta = 24.52\%$), operation is then on the verge of discontinuous conduction.

iii. T

If the switching frequency is decreased such that $T = t_x$, then the minimum period for discontinuous load current is given by equation (16.24). That is,

$$\begin{aligned} t_x = T &= t_T + \tau \ln \left(1 + \frac{V_s - E}{E} \left(1 - e^{-\frac{t_T}{\tau}} \right) \right) \\ T &= 1.25\text{ms} + 5\text{ms} \times \ln \left(1 + \frac{340\text{V} - 55\text{V}}{55\text{V}} \times \left(1 - e^{-\frac{1.25\text{ms}}{5\text{ms}}} \right) \right) = 5.07\text{ms} \end{aligned}$$

Discontinuous conduction operation occurs if the period is increased by more than 0.07ms.

In conclusion, for the given load, for continuous conduction to cease, the following operating conditions can be changed

- increase the back emf E from 55V to 56.2V
- decrease the duty cycle δ from 25% to 24.52% (t_T decreased from 1.25ms to 1.226ms)
- increase the switching period T by 0.07ms, from 5ms to 5.07ms (from 200Hz to 197.2Hz), with the switch on-time, t_T , unchanged from 1.25ms.

Appropriate simultaneous smaller changes in more than one parameter would suffice.



Example 16.3: DC chopper with load back emf – discontinuous conduction

A first-quadrant dc-to-dc chopper feeds an inductive load of 10 Ω resistance, 50mH inductance, and an opposing back emf of 100V dc, from a 340V dc source. If the chopper is operated at 200Hz with a 25% on-state duty cycle, determine:

- i. the load average and rms voltages;
- ii. the rms ripple voltage, hence ripple and form factors;
- iii. the maximum and minimum output current, hence the peak-to-peak output ripple in the current;
- iv. the current in the time domain;
- v. the load average current, average switch current and average diode current;
- vi. the input power, hence output power and rms output current;
- vii. effective input impedance, and electromagnetic efficiency; and
- viii. sketch the circuit, load, and output voltage and current waveforms.

Solution

The main circuit and operating parameters are

- on-state duty cycle $\delta = \frac{1}{4}$
- period $T = 1/f_s = 1/200\text{Hz} = 5\text{ms}$
- on-period of the switch $t_T = 1.25\text{ms}$
- load time constant $\tau = L/R = 0.05\text{mH}/10\Omega = 5\text{ms}$

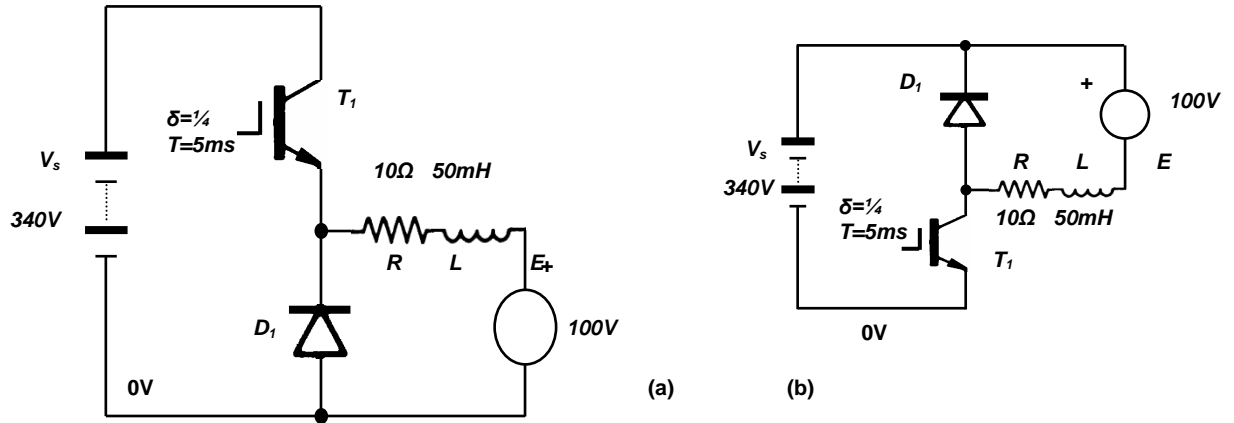

Figure 16.8. Example 16.3. Circuit diagram: (a) with load connected to ground and (b) load connected so that machine flash-over to ground (0V), by-passes the switch T_1 .

Confirmation of discontinuous load current can be obtained by evaluating the minimum current given by equation (16.13), that is

$$\hat{I} = \frac{V_s}{R} \frac{e^{\frac{t_r}{\tau}} - 1}{e^{\frac{T}{\tau}} - 1} - \frac{E}{R}$$

$$\hat{I} = \frac{340V}{10\Omega} \times \frac{e^{\frac{1.25ms}{5ms}} - 1}{e^{\frac{5ms}{5ms}} - 1} - \frac{100V}{10\Omega} = 5.62A - 10A = -4.38A$$

The minimum practical current is zero, so clearly discontinuous current periods exist in the load current. The equations applicable to discontinuous load current need to be employed. The current extinction time is given by equation (16.24), that is

$$t_x = t_r + \tau \ln \left(1 + \frac{V_s - E}{E} \left(1 - e^{-\frac{t_r}{\tau}} \right) \right)$$

$$= 1.25ms + 5ms \times \ln \left(1 + \frac{340V - 100V}{100V} \times \left(1 - e^{-\frac{1.25ms}{5ms}} \right) \right)$$

$$= 1.25ms + 2.13ms = 3.38ms$$

i. From equations (16.28) and (16.29) the load average and rms voltages are

$$\bar{V}_o = \delta V_s + \frac{T - t_x}{T} E$$

$$= \frac{1}{4} \times 340V + \frac{5ms - 3.38ms}{5ms} \times 100V = 117.4V$$

$$V_{rms} = \sqrt{\delta V_s^2 + \frac{T - t_x}{T} E^2}$$

$$= \sqrt{\frac{1}{4} \times 340^2 + \frac{5ms - 3.38ms}{5ms} \times 100^2} = 179.3V \text{ rms}$$

ii. From equations (16.30) and (16.31) the rms ripple voltage, hence voltage ripple factor, are

$$V_r = \sqrt{V_{rms}^2 - \bar{V}_o^2}$$

$$= \sqrt{179.3^2 - 117.4^2} = 135.5V \text{ ac}$$

$$RF = \frac{V_r}{\bar{V}_o} = \frac{135.5V}{117.4V} = 1.15 \quad FF = \sqrt{RF^2 + 1} = \sqrt{1.15^2 + 1} = 1.52$$

iii. From equation (16.38), the maximum and minimum output current, hence the peak-to-peak output ripple in the current, are

$$\hat{I} = \frac{V_s - E}{R} \left(1 - e^{-\frac{t_r}{\tau}} \right)$$

$$= \frac{340V - 100V}{10\Omega} \times \left(1 - e^{-\frac{1.25ms}{5ms}} \right) = 5.31A$$

The minimum current is zero so the peak-to-peak ripple current is $\Delta i_o = 5.31\text{A}$.

iv. From equations (16.34) and (16.35), the current in the time domain is

$$\begin{aligned} i_o(t) &= \frac{V_s - E}{R} \left(1 - e^{-\frac{t}{\tau}} \right) \\ &= \frac{340\text{V} - 100\text{V}}{10\Omega} \times \left(1 - e^{-\frac{t}{5\text{ms}}} \right) \\ &= 24 \times \left(1 - e^{-\frac{t}{5\text{ms}}} \right) \quad (\text{A}) \quad \text{for } 0 \leq t \leq 1.25\text{ms} \\ i_o(t) &= -\frac{E}{R} \left(1 - e^{-\frac{t}{\tau}} \right) + \hat{I} e^{-\frac{t}{\tau}} \\ &= -\frac{100\text{V}}{10\Omega} \times \left(1 - e^{-\frac{t}{5\text{ms}}} \right) + 5.31 e^{-\frac{t}{5\text{ms}}} \\ &= 15.31 \times e^{-\frac{t}{5\text{ms}}} - 10 \quad (\text{A}) \quad \text{for } 0 \leq t \leq 2.13\text{ms} \\ i_o(t) &= 0 \quad \text{for } 3.38\text{ms} \leq t \leq 5\text{ms} \end{aligned}$$

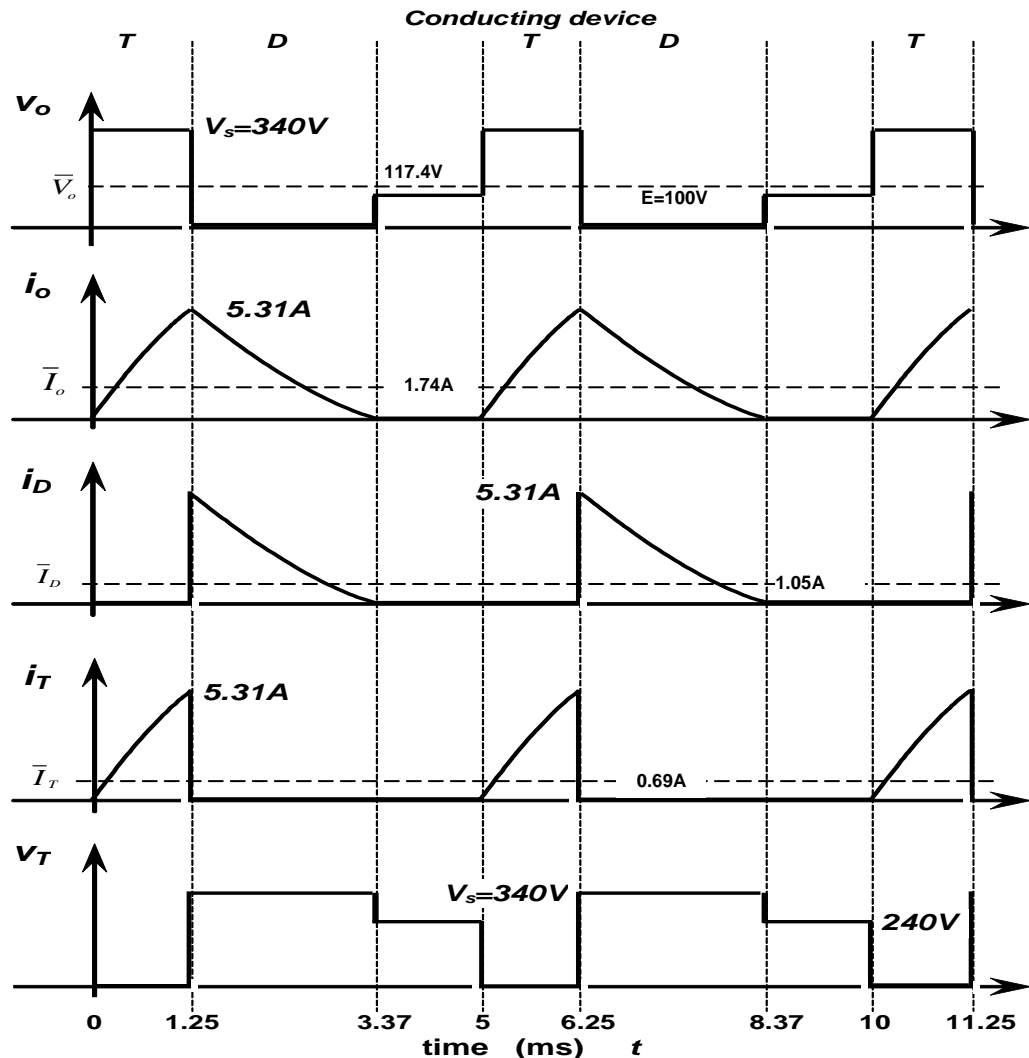

Figure 16.9. Example 16.3. Chopper circuit waveforms.

v. From equations (16.39) to (16.42), the average load current, average switch current, and average diode current are

$$\begin{aligned} \bar{I}_o &= \bar{V}_o - E/R \\ &= 117.4\text{V} - 100\text{V}/10\Omega = 1.74\text{A} \end{aligned}$$

$$\begin{aligned}\bar{I}_{diode} &= \frac{\tau}{T} \hat{I} - \frac{E \left(\frac{t_x}{T} - \delta \right)}{R} \\ &= \frac{5\text{ms}}{5\text{ms}} \times 5.31\text{A} - \frac{100\text{V} \times \left(\frac{3.38\text{ms}}{5\text{ms}} - 0.25 \right)}{10\Omega} = 1.05\text{A} \\ \bar{I}_i &= \bar{I}_o - \bar{I}_{diode} = 1.74\text{A} - 1.05\text{A} = 0.69\text{A}\end{aligned}$$

vi. From equation (16.40), the input power, hence output power and rms output current are

$$P_{in} = V_s \bar{I}_i = 340\text{V} \times 0.69\text{A} = 234.6\text{W}$$

$$P_{in} = P_{out} = I_{o\text{rms}}^2 R + E \bar{I}_o$$

Rearranging gives

$$\begin{aligned}I_{o\text{rms}} &= \sqrt{(P_{in} - E \bar{I}_o) / R} \\ &= \sqrt{234.6\text{W} - 100\text{V} \times 0.69\text{A} / 10\Omega} = 1.29\text{A}\end{aligned}$$

vii. From equations (16.44) and (16.45), the effective input impedance and electromagnetic efficiency, for $E > 0$ are

$$\begin{aligned}Z_{in} &= \frac{V_s}{\bar{I}_i} = \frac{340\text{V}}{0.69\text{A}} = 493\Omega \\ \eta &= \frac{E \bar{I}_o}{P_{in}} = \frac{E \bar{I}_o}{V_s \bar{I}_i} = \frac{100\text{V} \times 1.74\text{A}}{340\text{V} \times 0.69\text{A}} = 74.2\%\end{aligned}$$

viii. The circuit, load, and output voltage and current waveforms are plotted in figure 16.9.



16.3 Second-quadrant dc chopper, QII

The second-quadrant dc-to-dc chopper shown in figure 16.2b transfers energy from the load, back to the dc energy source V_s , a process called *regeneration*. Its operating principles are the same as those for the boost switch mode power supply analysed in chapter 19.4. The two energy transfer stages are shown in figure 16.10. Controlled energy transfer from the back emf E to the supply V_s , is achieved by varying the switch T_2 on-state duty cycle. Two modes of transfer can occur, as with the first-quadrant chopper already considered. The current in the load inductor can be either continuous or discontinuous, depending on the specific circuit parameters and operating conditions.

In this analysis, and all the choppers analysed, it is assumed that:

- No source impedance;
- Constant switch duty cycle;
- Steady-state conditions have been reached;
- Ideal semiconductors; and
- No load impedance temperature effects.

16.3.1 Continuous load inductor current

Load waveforms for continuous load current conduction are shown in figure 16.11a.

The output voltage v_o , load voltage, or switch voltage, is defined by

$$v_o(t) = \begin{cases} 0 & \text{for } 0 \leq t \leq t_T \\ V_s & \text{for } t_T \leq t \leq T \end{cases} \quad (16.46)$$

The mean load voltage is

$$\begin{aligned}\bar{V}_o &= \frac{1}{T} \int_0^T v_o(t) dt = \frac{1}{T} \int_{t_T}^T V_s dt \\ &= \frac{T - t_T}{T} V_s = (1 - \delta) V_s\end{aligned} \quad (16.47)$$

where the switch on-state duty cycle $\delta = t_T/T$ is defined in figure 16.11a.

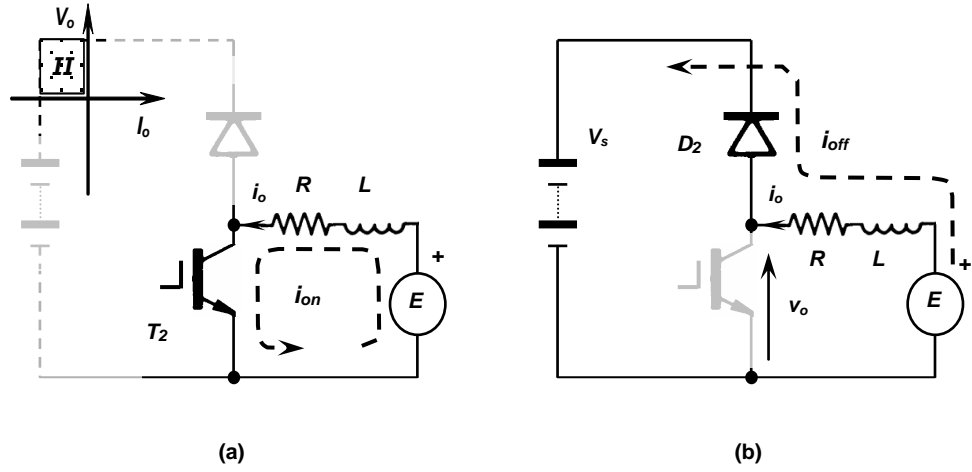

Figure 16.10. Stages of operation for the second-quadrant chopper: (a) switch-on, boosting current and (b) switch-off, energy into V_s .

Alternatively the voltage across the dc source V_s is

$$V_s = \frac{1}{1-\delta} \bar{V}_o \quad (16.48)$$

Since $0 \leq \delta \leq 1$, the step-up voltage ratio, to regenerate into V_s , is continuously adjustable from unity to infinity.

The average output current is

$$\bar{I}_o = \frac{E - \bar{V}_o}{R} = \frac{E - V_s(1-\delta)}{R} \quad (16.49)$$

The average output current can also be found by integration of the time domain output current i_o . By solving the appropriate time domain differential equations, the continuous load current i_o shown in figure 16.11a is defined by

During the **switch on-period**, when $v_o = 0$

$$L \frac{di_o}{dt} + R i_o = E$$

which yields

$$i_o(t) = \frac{E}{R} \left(1 - e^{-\frac{t}{\tau}} \right) + \hat{I} e^{-\frac{t}{\tau}} \quad \text{for } 0 \leq t \leq t_T \quad (16.50)$$

During the **switch off-period**, when $v_o = V_s$

$$L \frac{di_o}{dt} + R i_o + V_s = E$$

which, after shifting the zero time reference to t_T , gives

$$i_o(t) = \frac{E - V_s}{R} \left(1 - e^{-\frac{t}{\tau}} \right) + \hat{I} e^{-\frac{t}{\tau}} \quad \text{for } 0 \leq t \leq T - t_T \quad (16.51)$$

$$\text{where } \hat{I} = \frac{E}{R} - \frac{V_s}{R} \frac{e^{-\frac{t_T}{\tau}} - e^{-\frac{T}{\tau}}}{1 - e^{-\frac{T}{\tau}}} \quad (\text{A}) \quad (16.52)$$

$$\text{and } \check{I} = \frac{E}{R} - \frac{V_s}{R} \frac{1 - e^{-\frac{T-t_T}{\tau}}}{1 - e^{-\frac{T}{\tau}}} \quad (\text{A})$$

The output ripple current, for continuous conduction, is *independent* of the back emf E and is given by

$$I_{p-p} = \hat{I} - \check{I} = \frac{V_s}{R} \frac{(1 + e^{-\frac{T}{\tau}}) - (e^{-\frac{t_T}{\tau}} + e^{-\frac{T-t_T}{\tau}})}{1 - e^{-\frac{T}{\tau}}} \quad (16.53)$$

which in terms of the on-state duty cycle, $\delta = t_T/T$, becomes

$$I_{p-p} = \frac{V_s}{R} \frac{(1 - e^{-\frac{\delta T}{\tau}})(1 + e^{-\frac{T}{\tau}})}{1 - e^{-\frac{T}{\tau}}} \quad (16.54)$$

This is the same expression derived in 16.2.1 for the first-quadrant chopper. The normalised ripple current design curves in figure 16.3 are valid for the second-quadrant chopper.

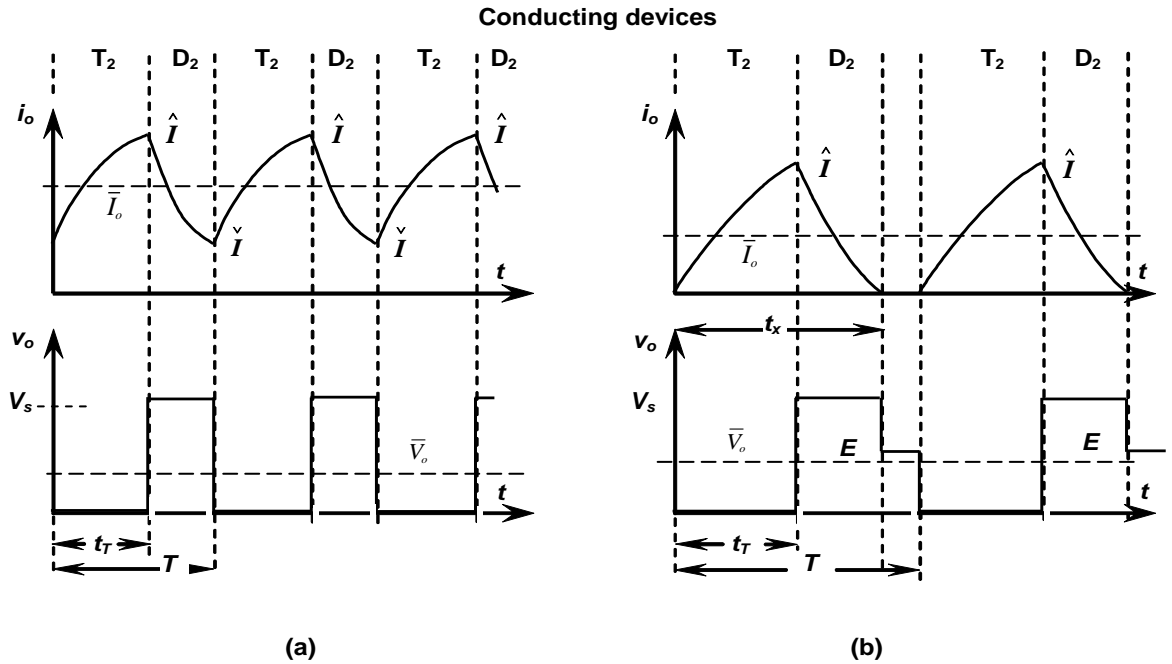

Figure 16.11. Second-quadrant chopper output modes of current operation: (a) continuous inductor current and (b) discontinuous inductor current.

The average switch current, \bar{I}_{switch} , can be derived by integrating the switch current given by equation (16.50), that is

$$\begin{aligned} \bar{I}_{switch} &= \frac{1}{T} \int_0^{t_r} i_o(t) dt \\ &= \frac{1}{T} \int_0^{t_r} \left(\frac{E}{R} \left(1 - e^{-\frac{t}{\tau}} \right) + \check{I} e^{-\frac{t}{\tau}} \right) dt \\ &= \frac{\delta E}{R} - \frac{\tau}{T} \left(\hat{I} - \check{I} \right) \end{aligned} \tag{16.55}$$

The term $\hat{I} - \check{I} = I_{p-p}$ is the peak-to-peak ripple current, which is given by equation (16.53). By Kirchoff's current law, the average diode current \bar{I}_{diode} is the difference between the average output current \bar{I}_o and the average switch current, \bar{I}_{switch} , that is

$$\begin{aligned} \bar{I}_{diode} &= \bar{I}_o - \bar{I}_{switch} \\ &= \frac{E - V_s(1 - \delta)}{R} - \frac{\delta E}{R} + \frac{\tau}{T} \left(\hat{I} - \check{I} \right) \\ &= \frac{\tau}{T} \left(\hat{I} - \check{I} \right) - \frac{(V_s - E)(1 - \delta)}{R} \end{aligned} \tag{16.56}$$

The average diode current can also be found by integrating the diode current given in equation (16.51), as follows

$$\begin{aligned} \bar{I}_{diode} &= \frac{1}{T} \int_0^{T-t_r} \left(\frac{E - V_s}{R} \left(1 - e^{-\frac{t}{\tau}} \right) + \hat{I} e^{-\frac{t}{\tau}} \right) dt \\ &= \frac{\tau}{T} \left(\hat{I} - \check{I} \right) - \frac{(V_s - E)(1 - \delta)}{R} \end{aligned} \tag{16.57}$$

The power produced (provide) by the back emf source E is

$$P_E = E \bar{I}_o = E \left(\frac{E - V_s(1 - \delta)}{R} \right) \tag{16.58}$$

The power delivered to the dc source V_s is

$$P_{V_s} = V_s \bar{I}_{diode} = V_s \left(\frac{\tau}{T} \left(\hat{I} - \check{I} \right) - \frac{(V_s - E)(1 - \delta)}{R} \right) \tag{16.59}$$

The difference between the two powers is the power lost in the load resistor, R , that is

$$P_E = P_{V_s} + I_{o,rms}^2 R$$

$$I_{o,rms} = \sqrt{\frac{E\bar{I}_o - V_s\bar{I}_{diode}}{R}} \quad (16.60)$$

The efficiency of energy transfer between the back emf E and the dc source V_s is

$$\eta = \frac{P_{V_s}}{P_E} = \frac{V_s\bar{I}_{diode}}{E\bar{I}_o} \quad (16.61)$$

16.3.2 Discontinuous load inductor current

With low duty cycles, δ , low inductance, L , or a relatively high dc source voltage, V_s , the minimum output current may reach zero at t_x , before the period T is complete ($t_x < T$), as shown in figure 16.11b. Equation (16.52) gives a boundary identity that must be satisfied for zero current,

$$\hat{I} = \frac{E}{R} - \frac{V_s}{R} \frac{1 - e^{-\frac{T-t_f}{\tau}}}{1 - e^{-\frac{T}{\tau}}} = 0 \quad (16.62)$$

That is

$$\frac{E}{V_s} = \frac{1 - e^{-\frac{-T+t_f}{\tau}}}{1 - e^{-\frac{-T}{\tau}}} \quad (16.63)$$

Alternatively, the time domain equations (16.50) and (16.51) can be used, such that $\hat{I} = 0$. An expression for the extinction time t_x can be found by substituting $t = t_f$ into equation (16.50). The resulting expression for \hat{I} is then substituted into equation (16.51) which is set to zero. Isolating the time variable, which becomes t_x , yields

$$\hat{I} = \frac{E}{R} \left(1 - e^{-\frac{t_f}{\tau}} \right)$$

$$0 = \frac{E - V_s}{R} \left(1 - e^{-\frac{t_x}{\tau}} \right) + \frac{E}{R} \left(1 - e^{-\frac{t_f}{\tau}} \right) e^{-\frac{t_x}{\tau}}$$

which yields

$$t_x = t_f + \tau \ln \left(1 + \frac{E}{V_s - E} \left(1 - e^{-\frac{t_f}{\tau}} \right) \right) \quad (16.64)$$

This equation shows that $t_x \geq t_f$. Load waveforms for discontinuous load current conduction are shown in figure 16.11b.

The output voltage v_o , load voltage, or switch voltage, is defined by

$$v_o(t) = \begin{cases} 0 & \text{for } 0 \leq t \leq t_f \\ V_s & \text{for } t_f \leq t \leq t_x \\ E & \text{for } t_x \leq t \leq T \end{cases} \quad (16.65)$$

The mean load voltage is

$$\bar{V}_o = \frac{1}{T} \int_0^T v_o(t) dt = \frac{1}{T} \left(\int_{t_f}^{t_x} V_s dt + \int_{t_x}^T E dt \right)$$

$$= \frac{t_x - t_f}{T} V_s + \frac{T - t_x}{T} E = \left(\frac{t_x}{T} - \delta \right) V_s + \left(1 - \frac{t_x}{T} \right) E$$

$$\bar{V}_o = E - \delta V_s + \frac{t_x}{T} (V_s - E) \quad (16.66)$$

where the switch on-state duty cycle $\delta = t_f/T$ is defined in figure 16.11b.

The average output current is

$$\bar{I}_o = \frac{E - \bar{V}_o}{R} = \frac{\delta V_s - \frac{t_x}{T} (V_s - E)}{R} \quad (16.67)$$

The average output current can also be found by integration of the time domain output current i_o . By solving the appropriate time domain differential equations, the continuous load current i_o shown in figure 16.11a is defined by

During the **switch on-period**, when $v_o = 0$

$$L \frac{di_o}{dt} + R i_o = E$$

which yields

$$i_o(t) = \frac{E}{R} \left(1 - e^{-\frac{t}{\tau}}\right) \quad \text{for } 0 \leq t \leq t_r \quad (16.68)$$

During the **switch off-period**, when $v_o = V_s$

$$L \frac{di_o}{dt} + R i_o + V_s = E$$

which, after shifting the zero time reference to t_r , gives

$$i_o(t) = \frac{E - V_s}{R} \left(1 - e^{-\frac{t}{\tau}}\right) + \hat{I} e^{-\frac{t}{\tau}} \quad \text{for } 0 \leq t \leq t_x - t_r \quad (16.69)$$

$$\text{where } \hat{I} = \frac{E}{R} \left(1 - e^{-\frac{t_r}{\tau}}\right) \quad (A) \quad (16.70)$$

$$\text{and } \hat{I} = 0 \quad (A)$$

After t_x , $v_o(t) = E$ and the load current is zero, that is

$$i_o(t) = 0 \quad \text{for } t_x \leq t \leq T \quad (16.71)$$

The output ripple current, for discontinuous conduction, is dependent of the back emf E and is given by equation (16.70),

$$I_{p-p} = \hat{I} = \frac{E}{R} \left(1 - e^{-\frac{t_r}{\tau}}\right) \quad (16.72)$$

The average switch current, \bar{I}_{switch} , can be derived by integrating the switch current given by equation (16.68), that is

$$\begin{aligned} \bar{I}_{switch} &= \frac{1}{T} \int_0^{t_r} i_o(t) dt \\ &= \frac{1}{T} \int_0^{t_r} \left(\frac{E}{R} \left(1 - e^{-\frac{t}{\tau}}\right) \right) dt \\ &= \frac{\delta E}{R} - \frac{\tau}{T} \hat{I} \end{aligned} \quad (16.73)$$

The term $\hat{I} = I_{p-p}$ is the peak-to-peak ripple current, which is given by equation (16.72). By Kirchoff's current law, the average diode current \bar{I}_{diode} is the difference between the average output current \bar{I}_o and the average switch current, \bar{I}_{switch} , that is

$$\begin{aligned} \bar{I}_{diode} &= \bar{I}_o - \bar{I}_{switch} \\ &= \frac{\delta V_s - \frac{t_x}{T} (V_s - E)}{R} - \frac{\delta E}{R} + \frac{\tau}{T} \hat{I} \\ &= \frac{\tau}{T} \hat{I} - \frac{\left(\frac{t_x}{T} - \delta\right) (V_s - E)}{R} \end{aligned} \quad (16.74)$$

The average diode current can also be found by integrating the diode current given in equation (16.69), as follows

$$\begin{aligned} \bar{I}_{diode} &= \frac{1}{T} \int_0^{t_x - t_r} \left(\frac{E - V_s}{R} \left(1 - e^{-\frac{t}{\tau}}\right) + \hat{I} e^{-\frac{t}{\tau}} \right) dt \\ &= \frac{\tau}{T} \hat{I} - \frac{\left(\frac{t_x}{T} - \delta\right) (V_s - E)}{R} \end{aligned} \quad (16.75)$$

The power produced by the back emf source E is

$$P_E = E \bar{I}_o \quad (16.76)$$

The power delivered to the dc source V_s is

$$P_{V_s} = V_s \bar{I}_{diode} \quad (16.77)$$

Alternatively, the difference between the two powers is the power lost in the load resistor, R , that is

$$P_E = P_{V_s} + I_{o,rms}^2 R$$

$$I_{o,rms} = \sqrt{\frac{E \bar{I}_o - V_s \bar{I}_{diode}}{R}} \quad (16.78)$$

The efficiency of energy transfer between the back emf and the dc source is

$$\eta = \frac{P_{V_s}}{P_E} = \frac{V_s \bar{I}_{diode}}{E \bar{I}_o} \quad (16.79)$$

Example 16.4: Second-quadrant DC chopper – continuous inductor current

A dc-to-dc chopper capable of second-quadrant operation is used in a 200V dc battery electric vehicle. The machine armature has 1Ω resistance in series with 1mH inductance.

- The machine is used for regenerative braking. At a constant speed downhill, the back emf is 150V, which results in a 10A braking current. What is the switch on-state duty cycle if the machine is delivering continuous output current? What is the minimum chopping frequency for these conditions?
- At this speed, (that is, $E = 150V$), determine the minimum duty cycle for continuous inductor current, if the switching frequency is 1kHz. What is the average braking current at the critical duty cycle? What is the regenerating efficiency and the rms machine output current?
- If the chopping frequency is increased to 5kHz, at the same speed, (that is, $E = 150V$), what is the critical duty cycle and the corresponding average dc machine current?

Solution

The main circuit operating parameters are

- $V_s = 200V$
- $E = 150V$
- load time constant $\tau = L/R = 1mH/1\Omega = 1ms$

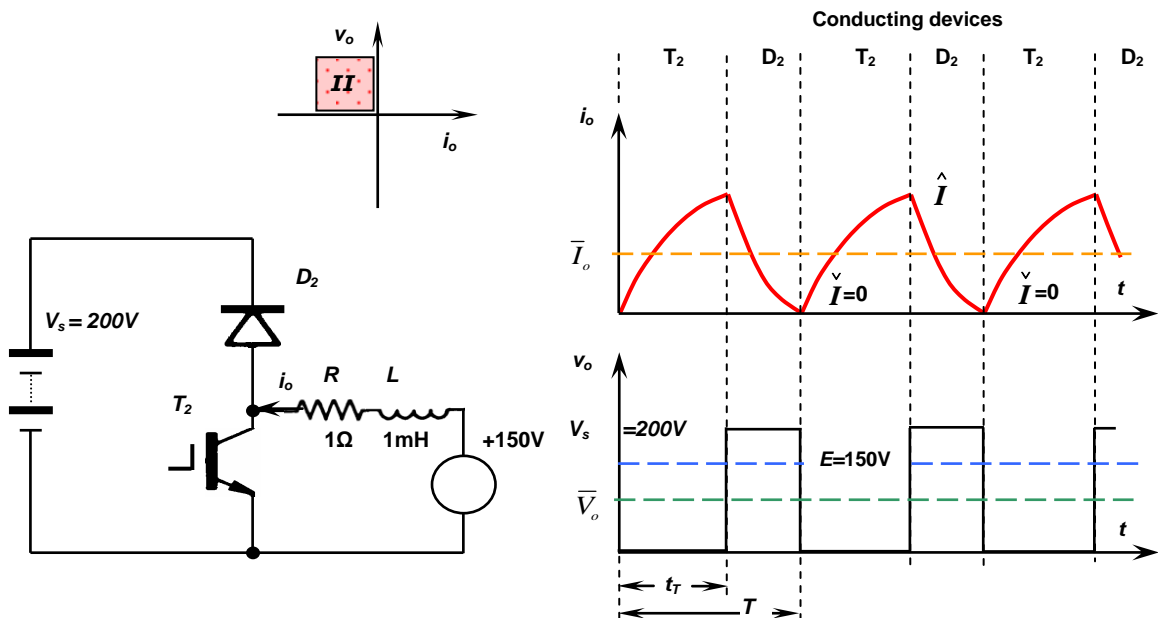

Figure 16.12. Example 16.4. Circuit diagram and waveforms.

- The relationship between the dc supply V_s and the dc machine back emf E is given by equation (16.49), that is

$$\bar{I}_o = \frac{E - \bar{V}_o}{R} = \frac{E - V_s(1 - \delta)}{R}$$

$$10A = \frac{150V - 200V \times (1 - \delta)}{1\Omega}$$

that is

$$\delta = 0.3 \equiv 30\% \quad \text{and} \quad \bar{V}_o = 140V$$

The expression for the average dc machine output current is based on continuous armature inductance current. Therefore the switching period must be shorter than the time t_x predicted by equation (16.64) for the current to reach zero, before the next switch on-period. That is, for $t_x = T$ and $\delta = 0.3$

$$t_x = t_r + \tau \ln \left(1 + \frac{E}{V_s - E} \left(1 - e^{-\frac{t_r}{\tau}} \right) \right)$$

This simplifies to

$$1 = 0.3 + \frac{1\text{ms}}{T} \ln \left(1 + \frac{150\text{V}}{200\text{V} - 150\text{V}} \left(1 - e^{-\frac{0.3T}{1\text{ms}}} \right) \right)$$

$$e^{0.7T} = 4 - 3e^{-0.3T}$$

Iteratively solving this transcendental equation gives $T = 0.4945\text{ms}$. That is the switching frequency must be greater than $f_s = 1/T = 2.022\text{kHz}$, else machine output current discontinuities occur, and equation (16.49) is invalid. The switching frequency can be reduced if the on-state duty cycle is increased as in the next part of this example.

ii. The operational boundary condition giving by equation (16.63), using $T = 1/f_s = 1/1\text{kHz} = 1\text{ms}$, yields

$$\frac{E}{V_s} = \frac{1 - e^{-\frac{T+t_r}{\tau}}}{1 - e^{-\frac{T}{\tau}}}$$

$$\frac{150\text{V}}{200\text{V}} = \frac{1 - e^{-\frac{(\delta-1) \times 1\text{ms}}{1\text{ms}}}}{1 - e^{-\frac{1\text{ms}}{1\text{ms}}}}$$

Solving gives $\delta = 0.357$. That is, the on-state duty cycle must be at least 35.7% for continuous machine output current at a switching frequency of 1kHz.

For continuous inductor current, the average output current is given by equation (16.49), that is

$$\bar{I}_o = \frac{E - \bar{V}_o}{R} = \frac{E - V_s(1 - \delta)}{R}$$

$$= \frac{150\text{V} - \bar{V}_o}{1\Omega} = \frac{150\text{V} - 200\text{V} \times (1 - 0.357)}{1\Omega} = 21.4\text{A}$$

$$\bar{V}_o = 150\text{V} - 21.4\text{A} \times 1\Omega = 128.6\text{V}$$

The average machine output current of 21.4A is split between the switch and the diode (which is in series with V_s).

The diode current is given by equation (16.56)

$$\bar{I}_{diode} = \bar{I}_o - \bar{I}_{switch}$$

$$= \frac{\tau}{T} \left(\hat{I} - \check{I} \right) - \frac{(V_s - E)(1 - \delta)}{R}$$

The minimum output current is zero while the maximum is given by equation (16.70).

$$\hat{I} = \frac{E}{R} \left(1 - e^{-\frac{t_r}{\tau}} \right) = \frac{150\text{V}}{1\Omega} \times \left(1 - e^{-\frac{0.357 \times 1\text{ms}}{1\text{ms}}} \right) = 45.0\text{A}$$

Substituting into the equation for the average diode current gives

$$\bar{I}_{diode} = \frac{1\text{ms}}{1\text{ms}} \times (45.0\text{A} - 0\text{A}) - \frac{(200\text{V} - 150\text{V}) \times (1 - 0.357)}{1\Omega} = 12.85\text{A}$$

The power delivered by the dc machine back emf E is

$$P_E = E \bar{I}_o = 150\text{V} \times 21.4\text{A} = 3210\text{W}$$

while the power delivered to the 200V battery source V_s is

$$P_{V_s} = V_s \bar{I}_{diode} = 200\text{V} \times 12.85\text{A} = 2570\text{W}$$

The regeneration transfer efficiency is

$$\eta = \frac{P_{V_s}}{P_E} = \frac{2570\text{W}}{3210\text{W}} = 80.1\%$$

The energy generated deficit, 640W (3210W - 2570W), is lost in the armature resistance, as I^2R heat dissipation. The output rms current is

$$I_{o,rms} = \sqrt{\frac{P}{R}} = \sqrt{\frac{640\text{W}}{1\Omega}} = 25.3\text{A rms}$$

iii. At an increased switching frequency of 5kHz, the duty cycle would be expected to be much lower than the 35.7% as at 1kHz. The operational boundary between continuous and discontinuous armature inductor current is given by equation (16.63), that is

$$\frac{E}{V_s} = \frac{1 - e^{\frac{-T+t_f}{\tau}}}{1 - e^{\frac{-T}{\tau}}}$$

$$\frac{150V}{200V} = \frac{1 - e^{\frac{(-1+\delta) \times 0.2ms}{1ms}}}{1 - e^{\frac{-0.2ms}{1ms}}}$$

which yields $\delta = 26.9\%$.

The machine average output current is given by equation (16.49)

$$\bar{I}_o = \frac{E - \bar{V}_o}{R} = \frac{E - V_s(1 - \delta)}{R}$$

$$= \frac{150V - \bar{V}_o}{1\Omega} = \frac{150V - 200V \times (1 - 0.269)}{1\Omega} = 3.8A$$

such that the average output voltage \bar{V}_o is 146.2V.

♣

16.4 Two-quadrant dc chopper - Q I and Q II

Figure 16.13 shows the basic two-quadrant dc chopper, which is a reproduction of the circuit in figure 16.2c. Depending on the load and operating conditions, the chopper can seamlessly change between and act in two modes

- Devices T_1 and D_1 form the first-quadrant chopper shown in figure 16.2a, and is analysed in section 16.2. Energy is delivered from the dc source V_s to the R - L - E load.
- Devices T_2 and D_2 form the second-quadrant chopper shown in figure 16.2b, which is analysed in section 16.3. Energy is delivered from the generating load dc source E , to the dc source V_s .

The two independent choppers can be readily combined as shown in figure 16.13a.

The average output voltage \bar{V}_o and the instantaneous output voltage v_o are never negative, whilst the average source current of V_s can be positive (Quadrant I) or negative (Quadrant II). If the two choppers are controlled to operate independently, with the constraint that T_1 and T_2 do not conduct simultaneously, then the analysis in sections 16.2 and 16.3 are valid. Alternately, it is not uncommon to unify the operation of the two choppers, as follows.

If the chopper is operated such that the switches T_1 and T_2 act in a complementary manner, that is either T_1 or T_2 is on, then some of the independent flexibility offered by each chopper is lost. Essentially the consequence of complementary switch operation is that no extended zero current periods exist in the output, as shown in figures 16.13a and b. Thus the equations describing the features of the first-quadrant chopper in section 16.2.1, for continuous load current, are applicable to this chopper, with slight modification to account for the fact that both the minimum and maximum currents can be negative.

The analysis for continuous inductor current in section 16.2 is valid, but the minimum current is not restricted to zero. Consequently four possible output modes can occur, depending on the relative polarity of the maximum and minimum currents shown in figure 16.13b and c.

- $\hat{V} > 0$, $\hat{I} > 0$ and $\bar{I}_o > 0$
When the minimum current (hence average output current) is greater than zero, the chopper is active in the first-quadrant. Typical output voltage and current waveforms are shown in figure 16.3a. The switch T_2 and diode D_2 do not conduct during any portion of the operating period.
- $\hat{V} < 0$, $\hat{I} > 0$ and $\bar{I}_o > 0$
When the minimum current is negative but the maximum positive current is larger in absolute magnitude, then for a highly inductive load, the average output current is greater than zero, and the chopper operates in the first-quadrant. If the load is not highly inductive the boundary is determined by the average output current $\bar{I}_o > 0$. The various circuit waveforms are shown in figure 16.13b.
- $\hat{V} < 0$, $\hat{I} > 0$ and $\bar{I}_o < 0$
For a highly inductive load, if the magnitude of the negative peak is greater than the positive maximum, the average is less than zero and the chopper is operating in the regenerative mode, quadrant II. If the load is not highly inductive the boundary is determined by the average output current $\bar{I}_o < 0$.
- $\hat{V} < 0$, $\hat{I} < 0$ and $\bar{I}_o < 0$
When the maximum current and the average current are both negative, the chopper is operational in the second-quadrant. Since the load current never goes positive, switch T_1 and diode D_1 never conduct, as shown in figure 16.13c.

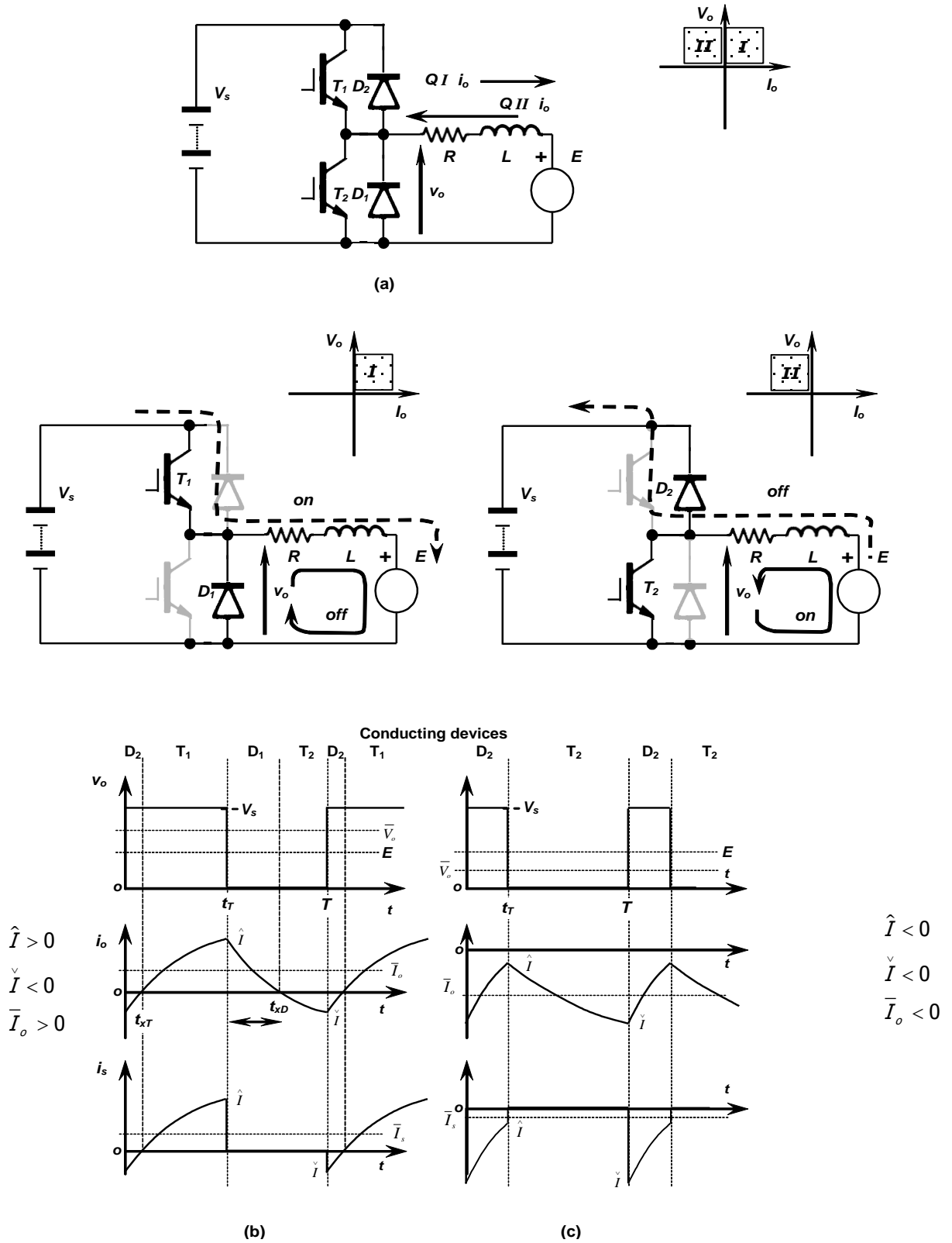

Figure 16.13. Two-quadrant (*I* and *II*) dc chopper circuit where $v_o > 0$:
 (a) basic two-quadrant dc chopper; (b) operation and waveforms for quadrant *I*; and (c) operation and waveforms for quadrant *II*, regeneration into V_s .

In all cases the average output voltage is solely determined by the switch T_1 on-time duty cycle, since when this switch is turned on the supply V_s is impressed across the load, independent of the direction of the load current. When $i_o > 0$, switch T_1 conducts while if $i_o < 0$, the diode in parallel to switch T_1 , namely D_1 conducts, clamping the load to V_s .

The output voltage, which is independent of the load, is described by

$$v_o(t) = \begin{cases} V_s & \text{for } 0 \leq t \leq t_T \\ 0 & \text{for } t_T \leq t \leq T \end{cases} \quad (16.80)$$

Thus

$$\bar{V}_o = \frac{1}{T} \int_0^{t_T} V_s dt = \frac{t_T}{T} V_s = \delta V_s \quad (16.81)$$

The rms output voltage is also determined solely by the duty cycle,

$$\begin{aligned} V_{rms} &= \left[\frac{1}{T} \int_0^{t_T} V_s^2 dt \right]^{1/2} \\ &= \sqrt{\delta} V_s \end{aligned} \quad (16.82)$$

The output ac ripple voltage, hence voltage ripple factor are given by equations (16.3) and (16.5), and are independent of the load:

$$V_r = \sqrt{V_{rms}^2 - V_o^2} = V_s \sqrt{\delta(1-\delta)} \quad (16.83)$$

and

$$RF = \frac{V_r}{\bar{V}_o} = \sqrt{\frac{1}{\delta} - 1} = \sqrt{\frac{1-\delta}{\delta}} \quad FF = \frac{1}{\sqrt{\delta}} \quad (16.84)$$

The Fourier series for the load voltage can be used to determine the load current at each harmonic frequency as described by equations (16.6) to (16.10).

The time domain differential equations from section 16.2.1 are also valid, where there is no zero restriction on the minimum load current value.

In a **positive voltage loop**, when $v_o(t) = V_s$ and V_s is impressed across the load, the load circuit condition is described by

$$i_o(t) = \frac{V_s - E}{R} \left(1 - e^{-\frac{t}{\tau}} \right) + \hat{I} e^{-\frac{t}{\tau}} \quad \text{for } 0 \leq t \leq t_T \quad (16.85)$$

During the **switch off-period**, when $v_o = 0$, forming a zero voltage loop

$$i_o(t) = -\frac{E}{R} \left(1 - e^{-\frac{t}{\tau}} \right) + \hat{I} e^{-\frac{t}{\tau}} \quad \text{for } 0 \leq t \leq T - t_T \quad (16.86)$$

where

$$\text{where } \hat{I} = \frac{V_s}{R} \frac{1 - e^{-\frac{t_T}{\tau}}}{1 - e^{-\frac{T}{\tau}}} - \frac{E}{R} \quad (A) \quad (16.87)$$

$$\text{and } \check{I} = \frac{V_s}{R} \frac{e^{-\frac{t_T}{\tau}} - 1}{e^{-\frac{T}{\tau}} - 1} - \frac{E}{R} \quad (A)$$

The peak-to-peak ripple current is independent of E ,

$$I_{p-p} = \frac{V_s}{R} \frac{(1 - e^{-\frac{\delta T}{\tau}})(1 - e^{-\frac{(1-\delta)T}{\tau}})}{1 - e^{-\frac{T}{\tau}}} \quad (16.88)$$

The average output current, \bar{I}_o , may be positive or negative and is given by

$$\begin{aligned} \bar{I}_o &= \frac{1}{T} \int_0^T i_o(t) dt = \frac{(\bar{V}_o - E)}{R} \\ &= \frac{(\delta V_s - E)}{R} \quad (A) \end{aligned} \quad (16.89)$$

The direction of the net power flow between E and V_s determines the chopper operating quadrant. If $\bar{V}_o > E$ then average power flow is to the load, as shown in figure 16.13b, while if $\bar{V}_o < E$, the average power flow is back into the source V_s , as shown in figure 16.13c.

$$V_s \bar{I}_s = \pm I_{o,rms}^2 R + E \bar{I}_o \quad (16.90)$$

Thus the sign of \bar{I}_o determines the direction of net power flow, hence quadrant of operation.

Calculation of individual device average currents in the time domain is complicated by the fact that the energy may flow between the dc source V_s and the load via the switch T_1 (energy to the load) or diode D_2 (energy from the load). It is therefore necessary to ascertain the zero current crossover time, when \hat{I} and \check{I} have opposite signs, which will then specify the necessary bounds of integration.

Equations (16.85) and (16.86) are equated to zero and solved for the time at zero crossover, t_{xT} and t_{xD} , respectively, shown in figure 16.13b.

$$t_{xT} = \tau \ln \left(1 - \frac{\check{I}R}{V_s - E} \right) \quad \text{with respect to } t = 0$$

$$t_{xD} = \tau \ln \left(1 + \frac{\hat{I}R}{E} \right) \quad \text{with respect to } t = t_T$$
(16.91)

The necessary integration for each device can then be determined with the aid of the device conduction information in the parts of figure 16.13 and Table 16.1.

Table 16.1: Device average current ratings

| Device and integration bounds, a to b | $\hat{I} > 0, \check{I} > 0$ | $\hat{I} > 0, \check{I} < 0$ | $\hat{I} < 0, \check{I} < 0$ |
|---|------------------------------|------------------------------|------------------------------|
| $\bar{I}_{T1} = \frac{1}{T} \int_a^b \frac{V_s - E}{R} \left(1 - e^{-\frac{t}{\tau}} \right) + \check{I} e^{-\frac{t}{\tau}} dt$ | 0 to t_T | t_{xT} to t_T | 0 to 0 |
| $\bar{I}_{D1} = \frac{1}{T} \int_0^b \frac{V_s - E}{R} \left(1 - e^{-\frac{t}{\tau}} \right) + \check{I} e^{-\frac{t}{\tau}} dt$ | 0 to 0 | 0 to t_{xT} | 0 to t_T |
| $\bar{I}_{T2} = \frac{1}{T} \int_a^b -\frac{E}{R} \left(1 - e^{-\frac{t}{\tau}} \right) + \hat{I} e^{-\frac{t}{\tau}} dt$ | 0 to 0 | t_{xD} to $T - t_T$ | 0 to $T - t_T$ |
| $\bar{I}_{D2} = \frac{1}{T} \int_0^b -\frac{E}{R} \left(1 - e^{-\frac{t}{\tau}} \right) + \hat{I} e^{-\frac{t}{\tau}} dt$ | 0 to $T - t_T$ | 0 to t_{xD} | 0 to 0 |

The electromagnetic energy transfer efficiency is determined from

$$\eta = \frac{E \bar{I}_o}{V_s \bar{I}_i} \quad \text{for } \bar{I}_o > 0$$

$$\eta = \frac{V_s \bar{I}_i}{E \bar{I}_o} \quad \text{for } \bar{I}_o < 0$$
(16.92)

Example 16.5: Two-quadrant DC chopper with load back emf

The two-quadrant dc-to-dc chopper in figure 16.13a feeds an inductive load of 10 Ω resistance, 50mH inductance, and back emf of 100V dc, from a 340V dc source. If the chopper is operated at 200Hz with a 25% on-state duty cycle, determine:

- i. the load average and rms voltages;
- ii. the rms ripple voltage, hence ripple and form factors;
- iii. the maximum and minimum output current, hence peak-to-peak output ripple in the current;
- iv. the current in the time domain;
- v. the current crossover times, if applicable;
- vi. the load average current, average switch current and average diode current for all devices;
- vii. the input power, hence output power and rms output current;
- viii. effective input impedance and electromagnetic efficiency; and
- ix. sketch the circuit, load, and output voltage and current waveforms.

Subsequently determine the necessary change in

- x. duty cycle δ to result in zero average output current and
- xi. back emf E to result in zero average load current.

Solution

The main circuit and operating parameters are

- on-state duty cycle $\delta = \frac{1}{4}$
- period $T = 1/f_s = 1/200\text{Hz} = 5\text{ms}$
- on-period of the switch $t_T = 1.25\text{ms}$
- load time constant $\tau = L/R = 0.05\text{mH}/10\Omega = 5\text{ms}$

i. From equations (16.81) and (16.82) the load average and rms voltages are

$$V_o = \frac{t_T}{T} V_s = \frac{1.25\text{ms}}{5\text{ms}} \times 340\text{V} = \frac{1}{4} \times 340\text{V} = 85\text{V}$$

$$V_{rms} = \sqrt{\delta} V_s = \sqrt{\frac{1}{4}} \times 340\text{V} = 170\text{V rms}$$

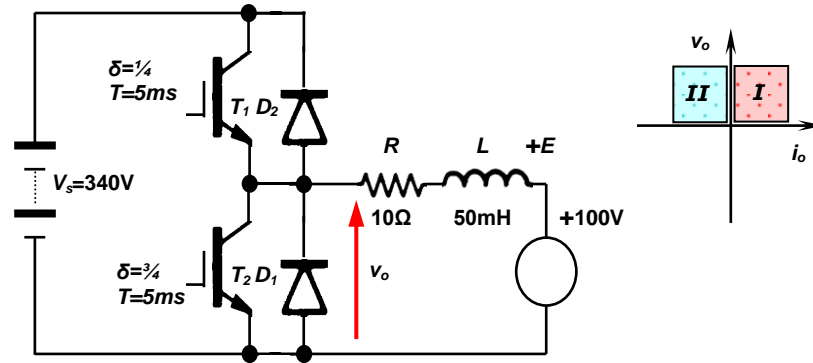

Figure 16.14. Example 16.5. Circuit diagram.

- ii. The rms ripple voltage, hence voltage ripple factor, from equations (16.83) and (16.84) are

$$V_r = \sqrt{V_{rms}^2 - V_o^2} = V_s \sqrt{\delta(1-\delta)}$$

$$= \sqrt{170^2 - 85^2} = 340V \sqrt{1/4 \times (1 - 1/4)} = 147.2V$$

$$RF = \frac{V_r}{V_o} = \sqrt{\frac{1}{\delta}} - 1 = \sqrt{\frac{1}{1/4}} - 1 = 1.732 \quad FF = \frac{1}{\sqrt{\delta}} = \frac{1}{\sqrt{1/4}} = 2$$

- iii. From equations (16.87) and (16.88), the maximum and minimum output current, hence the peak-to-peak output ripple in the load current are given by

$$\hat{I} = \frac{V_s}{R} \frac{1 - e^{-\frac{t_T}{\tau}}}{1 - e^{-\frac{T}{\tau}}} - \frac{E}{R} = \frac{340V}{10\Omega} \times \frac{1 - e^{-\frac{1.25ms}{5ms}}}{1 - e^{-\frac{5ms}{5ms}}} - \frac{100V}{10\Omega} = 1.90A$$

$$\check{I} = \frac{V_s}{R} \frac{e^{\frac{t_T}{\tau}} - 1}{e^{\frac{T}{\tau}} - 1} - \frac{E}{R} = \frac{340V}{10\Omega} \times \frac{e^{\frac{1.25ms}{5ms}} - 1}{e^{\frac{5ms}{5ms}} - 1} - \frac{100V}{10\Omega} = -4.38A$$

The peak-to-peak ripple current is therefore $\Delta i_o = 1.90A - (-4.38A) = 6.28A$ p-p.

- iv. The current in the time domain is given by equations (16.85) and (16.86)

$$i_o(t) = \frac{V_s - E}{R} \left(1 - e^{-\frac{t}{\tau}}\right) + \check{I} e^{-\frac{t}{\tau}}$$

$$= \frac{340V - 100V}{10\Omega} \times \left(1 - e^{-\frac{t}{5ms}}\right) - 4.38 \times e^{-\frac{t}{5ms}}$$

$$= 24 \times \left(1 - e^{-\frac{t}{5ms}}\right) - 4.38 \times e^{-\frac{t}{5ms}}$$

$$= 24 - 28.38 \times e^{-\frac{t}{5ms}} \quad \text{for } 0 \leq t \leq 1.25ms$$

$$i_o(t) = -\frac{E}{R} \left(1 - e^{-\frac{t}{\tau}}\right) + \hat{I} e^{-\frac{t}{\tau}}$$

$$= -\frac{100V}{10\Omega} \times \left(1 - e^{-\frac{t}{5ms}}\right) + 1.90 \times e^{-\frac{t}{5ms}}$$

$$= -10 \times \left(1 - e^{-\frac{t}{5ms}}\right) + 1.90 \times e^{-\frac{t}{5ms}}$$

$$= -10 + 11.90 \times e^{-\frac{t}{5ms}} \quad \text{for } 0 \leq t \leq 3.75ms$$

- v. Since the maximum current is greater than zero (1.9A) and the minimum is less than zero (-4.38A), the current crosses zero during the switch on-time and off-time. The time domain equations for the load current are solved for zero to give the cross over times t_{xT} and t_{xD} , as given by equation (16.91), or solved from the time domain output current equations as follows.

During the switch on-time

$$i_o(t) = 24 - 28.38 \times e^{\frac{-t}{5\text{ms}}} = 0 \quad \text{where } 0 \leq t = t_{xT} \leq 1.25\text{ms}$$

$$t_{xT} = 5\text{ms} \times \ln \frac{28.38}{24} = 0.838\text{ms}$$

During the switch off-time

$$i_o(t) = -10 + 11.90 \times e^{\frac{-t}{5\text{ms}}} = 0 \quad \text{where } 0 \leq t = t_{xD} \leq 3.75\text{ms}$$

$$t_{xD} = 5\text{ms} \times \ln \frac{11.90}{10} = 0.870\text{ms}$$

$$(1.250\text{ms} + 0.870\text{ms} = 2.12\text{ms with respect to switch } T_1 \text{ turn - on})$$

vi. The load average current, average switch current, and average diode current for all devices;

$$\bar{I}_o = \frac{(\bar{V}_o - E)}{R} = \frac{(\delta V_s - E)}{R}$$

$$\frac{(85\text{V} - 100\text{V})}{10\Omega} = -1.5\text{A}$$

When the output current crosses zero current, the conducting device changes. Table 16.1 gives the necessary current equations and integration bounds for the condition $\hat{I} > 0, \check{I} < 0$. Table 16.1 shows that all four semiconductors are involved in the output current cycle.

$$\bar{I}_{T1} = \frac{1}{T} \int_{t_{xT}}^{t_T} \frac{V_s - E}{R} \left(1 - e^{\frac{-t}{\tau}}\right) + \check{I} e^{\frac{-t}{\tau}} dt$$

$$= \frac{1}{5\text{ms}} \int_{0.838\text{ms}}^{1.25\text{ms}} 24 - 28.38 \times e^{\frac{-t}{5\text{ms}}} dt = 0.081\text{A}$$

$$\bar{I}_{D1} = \frac{1}{T} \int_0^{t_{xT}} \frac{V_s - E}{R} \left(1 - e^{\frac{-t}{\tau}}\right) + \check{I} e^{\frac{-t}{\tau}} dt$$

$$= \frac{1}{5\text{ms}} \int_0^{0.84\text{ms}} 24 - 28.38 \times e^{\frac{-t}{5\text{ms}}} dt = -0.357\text{A}$$

$$\bar{I}_{T2} = \frac{1}{T} \int_{t_{xD}}^{T-t_T} -\frac{E}{R} \left(1 - e^{\frac{-t}{\tau}}\right) + \hat{I} e^{\frac{-t}{\tau}} dt$$

$$= \frac{1}{5\text{ms}} \int_{0.870\text{ms}}^{3.75\text{ms}} -10 + 11.90 \times e^{\frac{-t}{5\text{ms}}} dt = -1.382\text{A}$$

$$\bar{I}_{D2} = \frac{1}{T} \int_0^{t_{xD}} -\frac{E}{R} \left(1 - e^{\frac{-t}{\tau}}\right) + \hat{I} e^{\frac{-t}{\tau}} dt$$

$$= \frac{1}{5\text{ms}} \int_0^{0.870\text{ms}} -10 + 11.90 \times e^{\frac{-t}{5\text{ms}}} dt = 0.160\text{A}$$

$$\text{Check } \bar{I}_o + \bar{I}_{T1} + \bar{I}_{D1} + \bar{I}_{T2} + \bar{I}_{D2} = -1.5\text{A} + 0.080\text{A} - 0.357\text{A} - 1.382\text{A} + 0.160\text{A} = 0$$

vii. The input power, hence output power and rms output current;

$$P_{in} = P_{V_s} = V_s \bar{I}_i = V_s (\bar{I}_{T1} + \bar{I}_{D1})$$

$$= 340\text{V} \times (0.080\text{A} - 0.357\text{A}) = -95.2\text{W}, \text{ (charging } V_s)$$

$$P_{out} = P_E = E \bar{I}_o = 100\text{V} \times (-1.5\text{A}) = -150\text{W}, \text{ that is generating } 150\text{W}$$

From

$$V_s I_s = I_{o,rms}^2 R + E \bar{I}_o$$

$$I_{o,rms} = \sqrt{\frac{P_{out} - P_{in}}{R}} = \sqrt{\frac{150\text{W} - 92.5\text{W}}{10\Omega}} = 2.34\text{A rms}$$

viii. Since the average output current is negative, energy is being transferred from the back emf E to the dc voltage source V_s , the electromagnetic efficiency of conversion is given by

$$\eta = \frac{V_s \bar{I}_i}{E \bar{I}_o} \quad \text{for } \bar{I}_o < 0$$

$$= \frac{95.2\text{W}}{150\text{W}} = 63.5\%$$

The effective input impedance is

$$Z_{in} = \frac{V_s}{\bar{I}_i} = \frac{V_s}{\bar{I}_{T1} + \bar{I}_{D1}} = \frac{340V}{0.080A - 0.357A} = -1214\Omega$$

ix. The circuit, load, and output voltage and current waveforms are sketched in the figure 16.15.

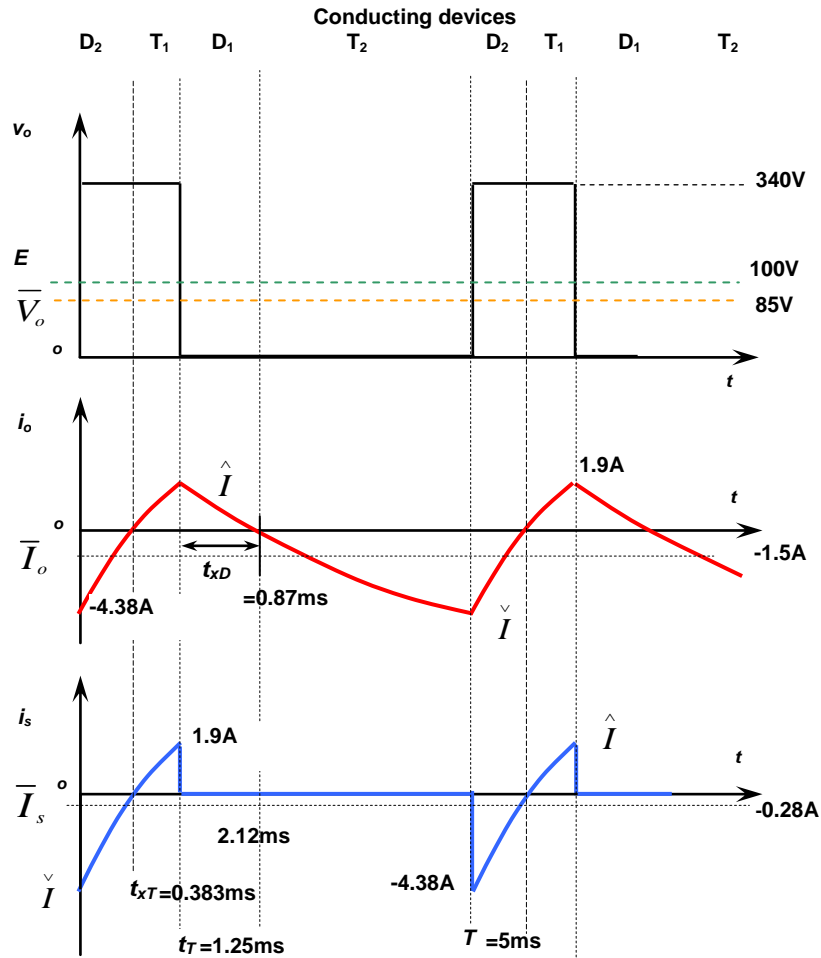

Figure 16.15. Example 16.5. *Circuit waveforms.*

x. Duty cycle δ to result in zero average output current can be determined from the expression for the average output current, equation (16.89), that is

$$\bar{I}_o = \frac{\delta V_s - E}{R} = 0$$

that is

$$\delta = \frac{E}{V_s} = \frac{100V}{340V} = 29.4\%$$

xi. As in part x, the average load current equation can be rearranged to give the back emf E that results in zero average load current

$$\bar{I}_o = \frac{\delta V_s - E}{R} = 0$$

that is

$$E = \delta V_s = \frac{1}{4} \times 340V = 85V$$



16.5 Two-quadrant dc chopper - Q I and Q IV

The unidirectional current, two-quadrant dc chopper, or asymmetrical half H-bridge shown in figure 16.16a incorporates two switches T_1 and T_4 and two complementary diodes D_1 and D_4 . In using switches T_1 and T_4 the chopper operates in the first and fourth quadrants, that is, bi-directional voltage output v_o but unidirectional load current, i_o .

The chopper can operate in two quadrants (I and IV), depending on the load and switching sequence. Net power can be delivered to the load, or received from the load provided the polarity of the back emf E is reversed. Because of this need to reverse the back emf for regeneration, this chopper is not commonly used in dc machine control. On the other hand, the chopper circuit configuration is commonly used to meet the converter requirements of the switched reluctance machine, which only requires unipolar current to operate. Also see chapter 19.6 for a bidirectional smps variation.

The asymmetrical half H-bridge chopper has three different output voltage states, where one state (the zero output state) has redundancy (two possibilities). Both the output voltage v_o and output current i_o are with reference to the first quadrant arrows in figure 16.16a.

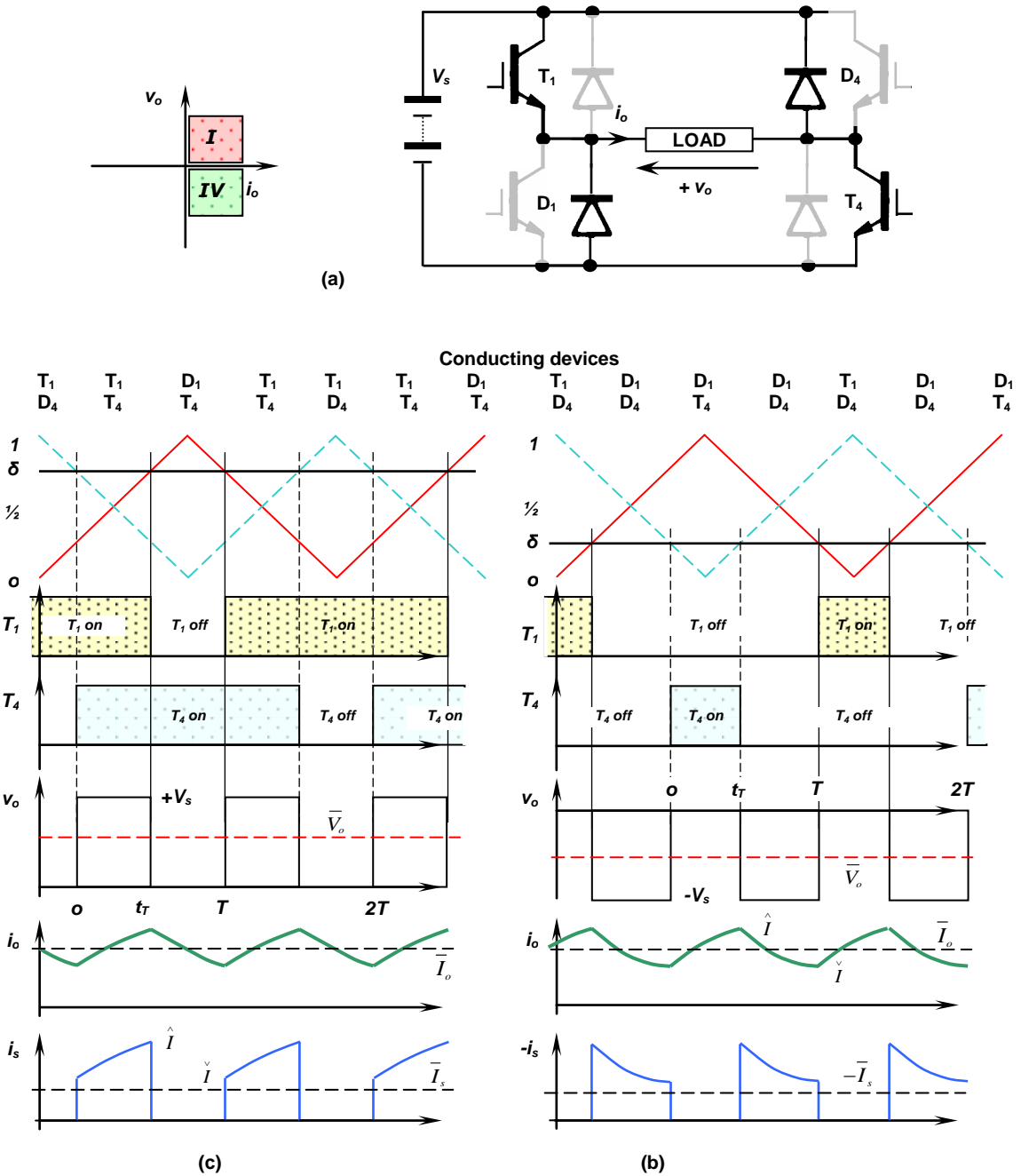

Figure 16.16. Two-quadrant (I and IV) dc chopper
 (a) circuit where $i_o > 0$; (b) operation in quadrant IV, regeneration into V_s ; and (c) operation in quadrant I.

State #1

When both switches T_1 and T_4 conduct, the supply V_s is impressed across the load, as shown in figure 16.17a. Energy is drawn from the dc source V_s .

T_1 and T_4 conducting: $v_o = V_s$

State #2

If only one switch is conducting, and therefore also one diode, the output voltage is zero, as shown in figure 16.17b. Either switch (but only one on at any time) can be the on-switch, hence providing redundancy, that is

$$\begin{array}{ll} T_1 \text{ and } D_4 \text{ conducting:} & v_o = 0 \\ T_4 \text{ and } D_1 \text{ conducting:} & v_o = 0 \end{array}$$

State #3

When both switches are off, the diodes D_1 and D_4 conduct load energy back into the dc source V_s , as in figure 16.17c. The output voltage is $-V_s$, that is

$$T_1 \text{ and } T_4 \text{ are not conducting: } v_o = -V_s$$

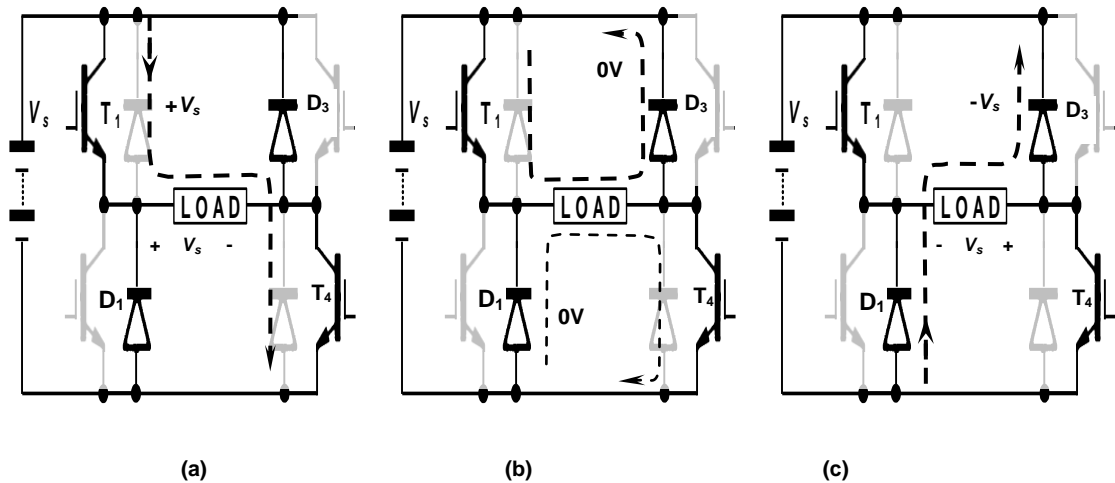

Figure 16.17. Two-quadrant (I and IV) dc chopper operational current paths: (a) T_1 and T_4 forming a $+V_s$ path; (b) T_1 and D_4 (or T_4 and D_1) forming a zero voltage loop; and (c) D_1 and D_4 creating a $-V_s$ path.

The two zero output voltage states can most effectively be used if alternated during any switching sequence. In this way, the load switching frequency (load ripple current frequency) is twice the switching frequency of the switches. This reduces the output current ripple for a given switch operating frequency (which minimises the load inductance necessary for continuous load current conduction). Also, by alternating the zero voltage loop, the semiconductor losses are evenly distributed. Specifically, a typical sequence to achieve these features would be

$$\begin{array}{ll} T_1 \text{ and } T_4 & V_s \\ T_1 \text{ and } D_4 & 0 \\ T_1 \text{ and } T_4 & V_s \\ T_4 \text{ and } D_1 & 0 \quad (\text{not } T_1 \text{ and } D_4 \text{ again}) \\ T_1 \text{ and } T_4 & V_s \\ T_1 \text{ and } D_4 & 0, \text{ etc.} \end{array}$$

The sequence can also be interleaved in the regeneration mode, when only one switch is on at any instant, as follows

$$\begin{array}{ll} D_1 \text{ and } D_4 & -V_s \quad (\text{that is } T_1 \text{ and } T_4 \text{ off}) \\ T_1 \text{ and } D_4 & 0 \\ D_1 \text{ and } D_4 & -V_s \\ T_4 \text{ and } D_1 & 0 \quad (\text{not } T_1 \text{ and } D_4 \text{ again}) \\ D_1 \text{ and } D_4 & -V_s \\ T_1 \text{ and } D_4 & 0, \text{ etc.} \end{array}$$

In switched reluctance motor drive application there may be no alternative to using only $\pm V_s$ control loops without the intermediate zero voltage state.

There are two basic modes of chopper switching operation.

- *Multilevel switching* is when both switches are controlled independently to give all three output voltage states (three levels), namely $\pm V_s$ and $0V$.
- *Bipolar switching* (or *two level switching*) is when both switches operate in unison, where they turn on together and off together. Only two voltage output states (hence the term bipolar), are possible, $+V_s$ and $-V_s$.

16.5.1 DC chopper:– Q I and Q IV – multilevel output voltage switching (three level)

The interleaved zero voltage states are readily introduced if the control carrier waveforms for the two switches are displaced by 180° , as shown in figure 16.16b and c, for continuous load current. This requirement can be realised if two up-down counters are displaced by 180° , when generating the necessary triangular carriers. As shown in figures 16.16b and c, the switching frequency $1/T_s$ is determined by the triangular wave frequency $1/2T$, whilst advantageously the load experiences twice that frequency, $1/T$, hence the output current has reduced ripple, for a given switch operating frequency.

i. $0 \leq \delta \leq \frac{1}{2}$

It can be seen in figure 16.16b that when $\delta \leq \frac{1}{2}$ both switches never conduct simultaneously hence the output voltage is either 0 or $-V_s$. Operation is in the fourth quadrant. The average output voltage is load independent and for $0 \leq \delta \leq \frac{1}{2}$, using the waveforms in figure 16.16b, is given by

$$\bar{V}_o = \frac{1}{T} \int_{t_T}^T -V_s dt = \frac{-V_s}{T} (T - t_T) = -V_s \left(1 - \frac{t_T}{T}\right) \quad (16.93)$$

Examination of figure 16.16b reveals that the relationship between t_T and δ must produce

$$\text{when } \delta = 0: \quad t_T = T \text{ and } v_o = -V_s$$

$$\text{when } \delta = \frac{1}{2}: \quad t_T = 0 \text{ and } v_o = 0$$

that is

$$\delta = \frac{1}{2} \frac{t_T}{T}$$

(the period of the carrier, $2T$, is twice the switching period, T) which after substituting for t_T/T in equation (16.93) gives

$$\begin{aligned} \bar{V}_o &= -V_s \left(1 - \frac{t_T}{T}\right) \\ &= -V_s (1 - 2\delta) = V_s (2\delta - 1) \quad \text{for } 0 \leq \delta \leq \frac{1}{2} \end{aligned} \quad (16.94)$$

Operational analysis in the fourth quadrant, $\delta \leq \frac{1}{2}$, is similar to the analysis for the second-quadrant chopper in figure 16.2b and analysed in section 16.3. Operation is characterised by first shorting the output circuit to boost the current, then removing the output short forces current back into the dc supply V_s , via a freewheel diode. The characteristics of this mode of operation are described by the equations (16.50) to (16.79) for the second-quadrant chopper analysed in 16.3, where the output current may again be continuous or discontinuous. The current and voltage references are both reversed in translating equations applicable in quadrants Q II to Q IV.

ii. $\frac{1}{2} \leq \delta \leq 1$

As shown in figure 16.16c, when $\delta \geq \frac{1}{2}$ and operation is in the first quadrant, at least one switch is conducting hence the output voltage is either $+V_s$ or 0. For continuous load current, the average output voltage is load independent and for $\frac{1}{2} \leq \delta \leq 1$ is given by

$$\bar{V}_o = \frac{1}{T} \int_0^{t_T} V_s dt = \frac{V_s}{T} t_T \quad (16.95)$$

Examination of figure 16.16c reveals that the relationship between t_T and δ must produce

$$\text{when } \delta = \frac{1}{2}: \quad t_T = 0 \text{ and } v_o = 0$$

$$\text{when } \delta = 1: \quad t_T = T \text{ and } v_o = V_s$$

that is

$$\delta = \frac{1}{2} \left(\frac{t_T}{T} + 1 \right)$$

which on substituting for t_T/T in equation (16.95) gives

$$\bar{V}_o = V_s \frac{t_T}{T} = V_s (2\delta - 1) \quad \text{for } \frac{1}{2} \leq \delta \leq 1 \quad (16.96)$$

Since the average output voltage is the same in each case, equations (16.94) and (16.96) for $(0 \leq \delta \leq 1)$, the output current mean is given by the same expression, namely

$$\bar{I}_o = \frac{\bar{V}_o - E}{R} = \frac{V_s (2\delta - 1) - E}{R} \quad (16.97)$$

Operation in the first quadrant, $\delta \geq \frac{1}{2}$, is characterised by the first-quadrant chopper shown in figure 16.2a and considered in section 16.2 along with the equations within that section. The load current can be either continuous, in which case equations (16.6) to (16.23) are valid; or discontinuous in which case equations (16.24) to (16.45) are applicable. Aspects of this mode of switching are extended in 16.5.3. In applying the equations for the chopper in section 16.2 for the first-quadrant chopper, and the equations in section 16.3 for the second-quadrant chopper, the duty cycle in each case is replaced by

- $2\delta - 1$ in the case of $\delta \geq \frac{1}{2}$ for the first-quadrant chopper and
- 2δ in the case of $\delta \leq \frac{1}{2}$ for the fourth-quadrant chopper.

This will account for the scaling and offset produced by the triangular carrier signal decoding.

16.5.2 DC chopper: – Q I and Q IV – bipolar voltage switching (two level)

When both switches operate in the same state, that is, both switches are on simultaneously or both are off together, operation is termed bipolar or two level switching.

From figure 16.18 the chopper output states are (assuming continuous load current)

- T_1 and T_4 on $v_o = V_s$
- T_1 and T_4 off $v_o = -V_s$

From figure 16.18, the average output voltage is

$$\begin{aligned} \bar{V}_o &= \frac{1}{T} \left(\int_0^{t_T} V_s dt + \int_{t_T}^T -V_s dt \right) \\ &= \frac{V_s}{T} (t_T - T + t_T) = (2\delta - 1)V_s \end{aligned} \tag{16.98}$$

The rms output voltage is independent of the duty cycle and is V_s .

The output ac ripple voltage is

$$\begin{aligned} V_r &= \sqrt{V_{rms}^2 - V_o^2} \\ &= \sqrt{V_s^2 - (2\delta - 1)^2 V_s^2} = 2V_s \sqrt{\delta(1 - \delta)} \end{aligned} \tag{16.99}$$

which is a maxima at $\delta = \frac{1}{2}$ and a minima for $\delta = 0$ and $\delta = 1$.

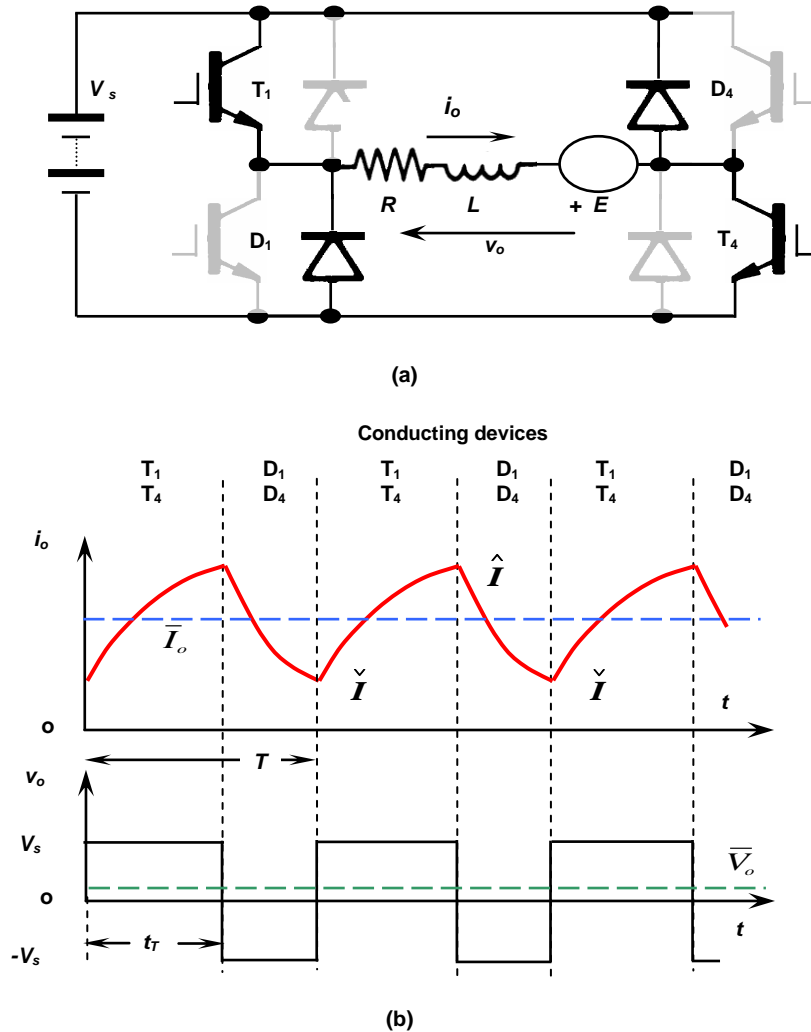

Figure 16.18. Two-quadrant (I and IV) dc chopper operation in the bipolar output mode: (a) circuit showing load components and (b) chopper output waveforms.

The output voltage ripple factor is

$$RF = \frac{V_r}{V_o} = \frac{2V_s \sqrt{\delta(1 - \delta)}}{(2\delta - 1)V_s} = \frac{2\sqrt{\delta(1 - \delta)}}{(2\delta - 1)} \tag{16.100}$$

Although the average output voltage may reverse, the load current is always positive but can be discontinuous or continuous. Equations describing bipolar output are presented within the next section, 16.5.3, which considers multilevel (two and three level) output voltage switch states.

16.5.3 Multilevel output voltage states, dc chopper

In switched reluctance machine drives it is not uncommon to operate the asymmetrical half H-bridge shown in figure 16.18 such that

- both switches operate in the on-state together to form $+V$ voltage loops;
- switches operate independently to give zero voltage loops; and
- both switches are simultaneously off, forming $-V$ voltage output loops.

The control objective is to generate a current output pulse that tracks a reference shape which starts from zero, rises to maintain a fixed current level, with hysteresis, then the current falls back to zero. The waveform shown in figure 16.19 fulfils this specification.

The switching strategy to produce the current waveform in figure 16.19 aims at:

- For rising current:- use $+V$ loops (and zero volt loops only if necessary)
- For near constant current:- use zero voltage loops (and $\pm V$ loops only if necessary to increase or decrease the current)
- For falling current:- use $-V$ loops (and zero volts loops only if necessary to reduce the fall rate)

Operation is further characterised by continuous load current during the pulse.

Energy is supplied to the load from the dc voltage source during $+V$ loops, and returned to the dc supply during $-V$ loop periods.

The chopper output current during each period is described by equations previously derived in this chapter, but reproduced as follows.

In a **positive voltage loop**, (T_1 and T_4 are both on), when $v_o(t) = V_s$ and V_s is impressed across the load, the load circuit condition is described by

$$L \frac{di_o}{dt} + R i_o + E = V_s$$

which yields

$$i_o(t) = \frac{V_s - E}{R} \left(1 - e^{-\frac{t}{\tau}} \right) + \check{I} e^{-\frac{t}{\tau}} \quad \text{for } 0 \leq t \leq t^+ \quad (16.101)$$

During the first switching cycle the current starts from zero, so $\check{I} = 0$. Otherwise \check{I} is the lower reference, I^- , from the end of the previous cycle.

The current at the end of the positive voltage loop period is the reference level I^+ , whilst the time to rise to I^+ is derived by equating equation (16.101) to I^+ and solving for time t^+ at the end of the period. Solving $i_o(t^+) = I^+$ for t^+ , gives

$$t^+ = \tau \ln \left(\frac{V_s - E - \check{I} R}{V_s - E - I^+ R} \right) \quad (16.102)$$

In a **zero voltage loop**, when $v_o(t) = 0$, such as circuit loops involving T_1 and D_4 (or T_4 and D_1), the circuit equation is given by

$$L \frac{di_o}{dt} + R i_o + E = 0$$

which gives

$$i_o(t) = -\frac{E}{R} \left(1 - e^{-\frac{t}{\tau}} \right) + \hat{I} e^{-\frac{t}{\tau}} \quad \text{for } 0 \leq t \leq t^o \quad (16.103)$$

where \hat{I} equals the reference current level, I^+ from the previous switching period.

The current at the end of the period is the reference level I^- , whilst the time to fall to I^- is given by equating equation (16.103) to I^- and solving for time, t^o at the end of the period.

$$t^o = \tau \ln \left(\frac{E + \hat{I} R}{E + I^- R} \right) \quad (16.104)$$

In a **negative voltage loop**, when both switches T_1 and T_4 are off, the current falls rapidly and the circuit equation, when $v_o(t) = -V_s$, is

$$L \frac{di_o}{dt} + R i_o + E = -V_s$$

which gives

$$i_o(t) = \frac{-E - V_s}{R} \left(1 - e^{-\frac{t}{\tau}} \right) + \hat{I} e^{-\frac{t}{\tau}} \quad \text{for } 0 \leq t \leq t^- \quad (16.105)$$

where \hat{I} equals the reference current level, I^+ from the previous switching period.

The current at the end of the period is I^- , whilst the time to reach I^- is given by equating equation (16.103) to I^- and solving for time t^- at the end of the period.

$$t^- = \tau \ln \left(\frac{V_s + E + \hat{I}R}{V_s + E + I^-R} \right) \quad (16.106)$$

The same equation is used to determine the time for the final current period when the current decays to zero, whence $I^- = 0$.

The characteristics and features of the three output voltage states are illustrated in the following example, 16.6.

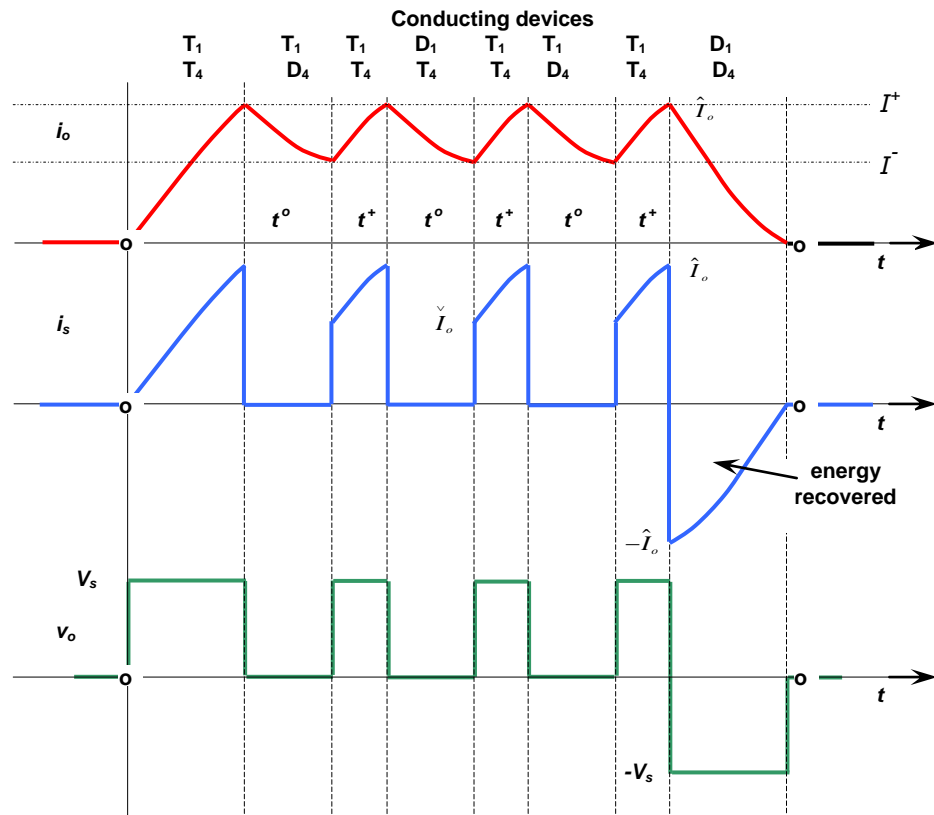

Figure 16.19. Two-quadrant (I and IV) dc chopper operation in a multilevel output voltage mode.

Example 16.6: Asymmetrical, half H-bridge, dc chopper

The asymmetrical half H-bridge, dc-to-dc chopper in figure 16.18 feeds an inductive load of 10 Ω resistance, 50mH inductance, and back emf of 55V dc, from a 340V dc voltage source. The chopper output current is controlled in a hysteresis mode within a current band between limits 5A and 10A. Determine the period of the current shape shown in the figure 16.20:

- i. when only $\pm V_s$ loops are used and
- ii. when a zero volt loop is used to maintain tracking within the 5A band.

In each case calculate the switching frequency if the current were to be maintained within the hysteresis band for a prolonged period. How do the on-state losses compare between the two control approaches?

Solution

The main circuit and operating parameters are

- $E = 55\text{V}$ and $V_s = 340\text{V}$
- load time constant $\tau = L/R = 0.05\text{mH}/10\Omega = 5\text{ms}$
- $I^+ = 10\text{A}$ and $I^- = 5\text{A}$

Examination of the figure 16.20 shows that only one period of the cycle differs, namely the second period, t_2 , where the current is required to fall to the lower hysteresis band level, -5A . The period of the other three regions (t_1 , t_3 , and t_4) are common and independent of the period of the second region, t_2 .

t₁: The first period, the initial rise time, $t^+ = t_1$ is given by equation (16.102), where $I^+ = 10\text{A}$ and $\hat{I} = 0\text{A}$.

$$t^+ = \tau \ln \left(\frac{V_s - E - \hat{I}R}{V_s - E - I^+R} \right)$$

$$\text{that is } t_1 = 5\text{ms} \times \ln \left(\frac{340\text{V} - 55\text{V} - 0\text{A} \times 10\Omega}{340\text{V} - 55\text{V} - 10\text{A} \times 10\Omega} \right) = 2.16\text{ms}$$

t₃: In the third period, the current rises from the lower hysteresis band limit of 5A to the upper band limit 10A . The duration of the current increase is given by equation (16.102) again, but with $\hat{I} = I^- = 5\text{A}$.

$$t^+ = \tau \ln \left(\frac{V_s - E - \hat{I}R}{V_s - E - I^+R} \right)$$

$$\text{that is } t_3 = 5\text{ms} \times \ln \left(\frac{340\text{V} - 55\text{V} - 5\text{A} \times 10\Omega}{340\text{V} - 55\text{V} - 10\text{A} \times 10\Omega} \right) = 1.20\text{ms}$$

t₄: The fourth and final period is a negative voltage loop where the current falls from the upper band limit of 10A to I^- which equals zero. From equation (16.106) with $\hat{I} = I^+ = 10\text{A}$ and $I^- = 0\text{A}$

$$t^- = \tau \ln \left(\frac{V_s + E + \hat{I}R}{V_s + E + I^-R} \right)$$

$$\text{that is } t_4 = 5\text{ms} \times \ln \left(\frac{340\text{V} + 55\text{V} + 10\text{A} \times 10\Omega}{340\text{V} + 55\text{V} + 0\text{A} \times 10\Omega} \right) = 1.13\text{ms}$$

The current pulse period is given by

$$\begin{aligned} T_p &= t_1 + t_2 + t_3 + t_4 \\ &= 2.16\text{ms} + t_2 + 1.20\text{ms} + 1.13\text{ms} \\ &= 4.49\text{ms} + t_2 \end{aligned}$$

i. t₂: When only $-V_s$ paths are used to decrease the current, the time t_2 is given by equation (16.106), with $I^- = 5\text{A}$ and $\hat{I} = 10\text{A}$,

$$t^- = \tau \ln \left(\frac{V_s + E + \hat{I}R}{V_s + E + I^-R} \right)$$

$$\text{that is } t_2 = 5\text{ms} \times \ln \left(\frac{340\text{V} + 55\text{V} + 10\text{A} \times 10\Omega}{340\text{V} + 55\text{V} + 5\text{A} \times 10\Omega} \right) = 0.53\text{ms}$$

The total period, T_p , of the chopped current pulse when a 0V loop is not used, is

$$\begin{aligned} T_p &= t_1 + t_2 + t_3 + t_4 \\ &= 2.16\text{ms} + 0.53\text{ms} + 1.20\text{ms} + 1.13\text{ms} = 5.02\text{ms} \end{aligned}$$

ii. t₂: When a zero voltage loop is used to maintain the current within the hysteresis band, the current decays slowly, and the period time t_2 is given by equation (16.104), with $I^- = 5\text{A}$ and $\hat{I} = 10\text{A}$,

$$t^o = \tau \ln \left(\frac{E + \hat{I}R}{E + I^-R} \right)$$

$$\text{that is } t_2 = 5\text{ms} \times \ln \left(\frac{55\text{V} + 10\text{A} \times 10\Omega}{55\text{V} + 5\text{A} \times 10\Omega} \right) = 1.95\text{ms}$$

The total period, T_p , of the chopped current pulse when a 0V loop is used, is

$$\begin{aligned} T_p &= t_1 + t_2 + t_3 + t_4 \\ &= 2.16\text{ms} + 1.95\text{ms} + 1.20\text{ms} + 1.13\text{ms} = 6.44\text{ms} \end{aligned}$$

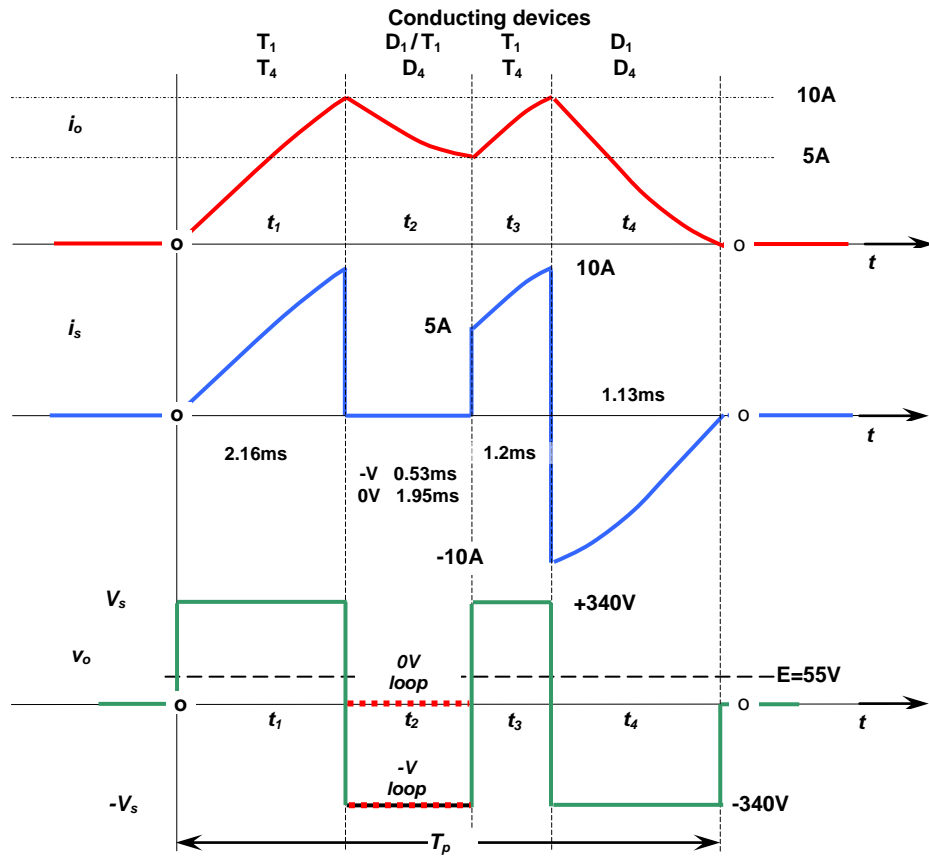

Figure 16.20. Example 16.6. Circuit waveforms.

The current falls significantly faster within the hysteresis band if negative voltage loops are employed rather than zero voltage loops, 0.53ms versus 1.95ms.

The switching frequency within the current bounds has a period $t_2 + t_3$, and each case is summarized in the following table. For longer current chopping, t_2 and t_3 dominate the switching frequency.

Using zero voltage current loops (alternated) reduces the switching frequency of the H-bridge switches by a factor of over three, for a given peak-to-peak ripple current.

If the on-state voltage drop of the switches and the diodes are similar for the same current level, then the on-state losses are similar, and evenly distributed for both control methods. The on-state losses are similar because each of the three states always involves the same current variation flowing through two semiconductors. The principal difference is in the significant increase in switching losses when only $\pm V$ loops are used (1:3.42).

Table 16.2 Example 16.6. Switching losses.

| Voltage loops | $t_2 + t_3$ | Current ripple frequency | Switch frequency | Switch loss ratio |
|---------------|---|--------------------------|------------------|--------------------------|
| $\pm V$ | $0.53\text{ms} + 1.20\text{ms} = 1.73\text{ms}$ | 578Hz | 578Hz | $\frac{578}{169} = 3.42$ |
| +V and zero | $1.95\text{ms} + 1.20\text{ms} = 3.15\text{ms}$ | 317Hz | 169Hz | 1 |



16.6 Four-quadrant dc chopper

The four-quadrant H-bridge dc chopper is shown in figure 16.21 where the load current and voltage are referenced with respect to T_1 , so that the quadrant of operation with respect to the switch number is persevered.

The H-bridge is a flexible basic configuration where its use to produce single-phase ac is considered in chapter 17.1.1, while its use in smps applications is considered in chapter 19.8.2. It can also be used as a dc chopper for the four-quadrant control of a dc machine.

With the flexibility of four switches, a number of different control methods can be used to produce four-quadrant output voltage and current (bidirectional voltage and current). All practical methods should employ complementary device switching in each leg (either T_1 or T_4 on but not both and either T_2 or T_3 on, but not both) so as to minimise distortion by ensuring current continuity around zero current output. One control method involves controlling the H-bridge as two virtually independent two-quadrant choppers, with the over-riding restriction that no two switches in the same leg conduct simultaneously. One chopper is formed with T_1 and T_4 grouped with D_1 and D_4 , which gives positive current i_o but bidirectional voltage $\pm v_o$ (QI and QIV operation). The second chopper is formed by grouping T_2 and T_3 with D_2 and D_3 , which gives negative output current $-i_o$, but bi-direction voltage $\pm v_o$ (QII and QIII operation).

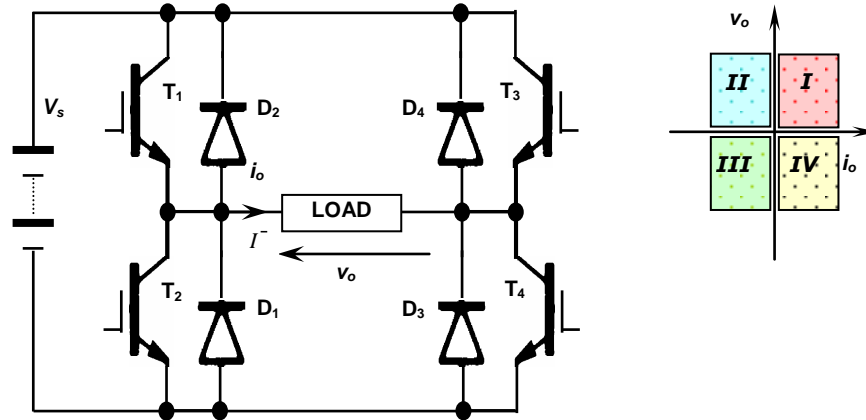

Figure 16.21. Four-quadrant dc chopper circuit, showing first quadrant i_o and v_o references.

The second control method is to unify the operation of all four switches within a generalised control algorithm.

With both control methods, the chopper output voltage can be either multilevel or bipolar, depending on whether zero output voltage loops are employed or not. Bipolar output states increase the ripple current magnitude, but do facilitate faster current reversal, without crossover distortion. Operation is independent of the direction of the output current i_o .

Since the output voltage is reversible for each control method, a triangular based modulation control method, as used with the asymmetrical H-bridge dc chopper in figure 16.16, is applicable in each case. Two generalised unified H-bridge control approaches are considered – bipolar and three-level output.

16.6.1 Unified four-quadrant dc chopper - bipolar voltage output switching

The simpler output to generate is bipolar output voltages, which use one reference carrier triangle as shown in figure 16.22 parts (c) and (d). The output voltage switches between $+V_s$ and $-V_s$ and the relative duration of each state depends on the magnitude of the modulation index δ .

If $\delta = 0$ then T_1 and T_4 never turn-on since T_2 and T_3 conduct continuously which impresses $-V_s$ across the load.

At the other extreme, if $\delta = 1$ then T_1 and T_4 are on continuously and $+V_s$ is impressed across the load.

If $\delta = \frac{1}{2}$ then T_1 and T_4 are turned on for half of the period T , while T_2 and T_3 are on for the remaining half of the period. The output voltage is $-V_s$ for half of the time and $+V_s$ for the remaining half of any period. The average output voltage is therefore zero, but disadvantageously, the output current needlessly ripples about zero (with an average value of zero).

The chopper output voltage is defined in terms of the triangle voltage reference level v_Δ by

- $v_\Delta > \delta, v_o = -V_s$
- $v_\Delta < \delta, v_o = +V_s$

From figure 16.22c and d, the average output voltage varies linearly with δ such that

$$\begin{aligned} \bar{V}_o &= \frac{1}{T} \left(\int_0^{t_T} +V_s dt + \int_{t_T}^T -V_s dt \right) \\ &= \frac{1}{T} (2t_T - T)V_s = \left(2\frac{t_T}{T} - 1 \right) V_s \end{aligned} \quad (16.107)$$

Examination of figures 16.22c and d reveals that the relationship between t_T and δ must produce

$$\text{when } \delta = 0: \quad t_T = 0 \quad \text{and} \quad v_o = -V_s$$

$$\text{when } \delta = 1/2: \quad t_T = 1/2T \quad \text{and} \quad v_o = 0$$

$$\text{when } \delta = 1: \quad t_T = T \quad \text{and} \quad v_o = +V_s$$

that is

$$\delta = \frac{t_T}{T}$$

which on substituting for t_T/T in equation (16.107) gives

$$\begin{aligned} \bar{V}_o &= \left(2 \frac{t_T}{T} - 1\right) V_s \\ &= (2\delta - 1) V_s \quad \text{for } 0 \leq \delta \leq 1 \end{aligned} \quad (16.108)$$

The average output voltage can be positive or negative, depending solely on δ . No current discontinuity occurs since the output voltage is never actually zero. Even when the average voltage is zero, ripple current flows though the load, with an average value of zero amps.

The rms output voltage is independent of the duty cycle and is V_s .

The output ac ripple voltage is

$$\begin{aligned} V_r &= \sqrt{V_{rms}^2 - V_o^2} \\ &= \sqrt{V_s^2 - (2\delta - 1)^2 V_s^2} = 2V_s \sqrt{\delta(1 - \delta)} \end{aligned} \quad (16.109)$$

The ac ripple voltage is zero at $\delta = 0$ and $\delta = 1$, when the output voltage is pure dc, namely $-V_s$ or V_s , respectively. The maximum ripple voltage occurs at $\delta = 1/2$, when $V_r = V_s$.

The output voltage ripple factor is

$$\begin{aligned} RF &= \frac{V_r}{V_o} = \frac{2V_s \sqrt{\delta(1 - \delta)}}{(2\delta - 1)V_s} \\ &= \frac{2\sqrt{\delta(1 - \delta)}}{(2\delta - 1)} = \sqrt{\left(\frac{1}{2\delta - 1}\right)^2 - 1} = \sqrt{FF^2 - 1} \end{aligned} \quad (16.110)$$

Circuit operation is characterized by two time domain equations:

During the **on-period for T1 and T4**, when $v_o(t) = V_s$

$$L \frac{di_o}{dt} + R i_o + E = V_s$$

which yields

$$i_o(t) = \frac{V_s - E}{R} \left(1 - e^{-\frac{t}{\tau}}\right) + \hat{I} e^{-\frac{t}{\tau}} \quad \text{for } 0 \leq t \leq t_T \quad (16.111)$$

During the **on-period for T2 and T3**, when $v_o(t) = -V_s$

$$L \frac{di_o}{dt} + R i_o + E = -V_s$$

which, after shifting the zero time reference to t_T , gives

$$i_o(t) = -\frac{V_s + E}{R} \left(1 - e^{-\frac{t}{\tau}}\right) + \hat{I} e^{-\frac{t}{\tau}} \quad \text{for } 0 \leq t \leq T - t_T \quad (16.112)$$

The initial conditions \hat{I} and \check{I} are determined by using the steady-state boundary conditions:

$$\text{where } \hat{I} = \frac{V_s}{R} \frac{1 - 2e^{-\frac{t_T}{\tau}} + e^{-\frac{T}{\tau}}}{1 - e^{-\frac{T}{\tau}}} - \frac{E}{R} \quad (A) \quad (16.113)$$

$$\text{and } \check{I} = \frac{V_s}{R} \frac{2e^{-\frac{t_T}{\tau}} - 1 + e^{-\frac{T}{\tau}}}{1 - e^{-\frac{T}{\tau}}} - \frac{E}{R} \quad (A)$$

The peak-to-peak ripple current is independent of load emf, E , and twice that given by equation (16.15).

The mean output current is given by

$$\bar{I}_o = \frac{(\bar{V}_o - E)}{R} = \frac{((1 - 2\delta)V_s - E)}{R} \quad (A) \quad (16.114)$$

which can be positive or negative, as seen in figure 16.22c and d.

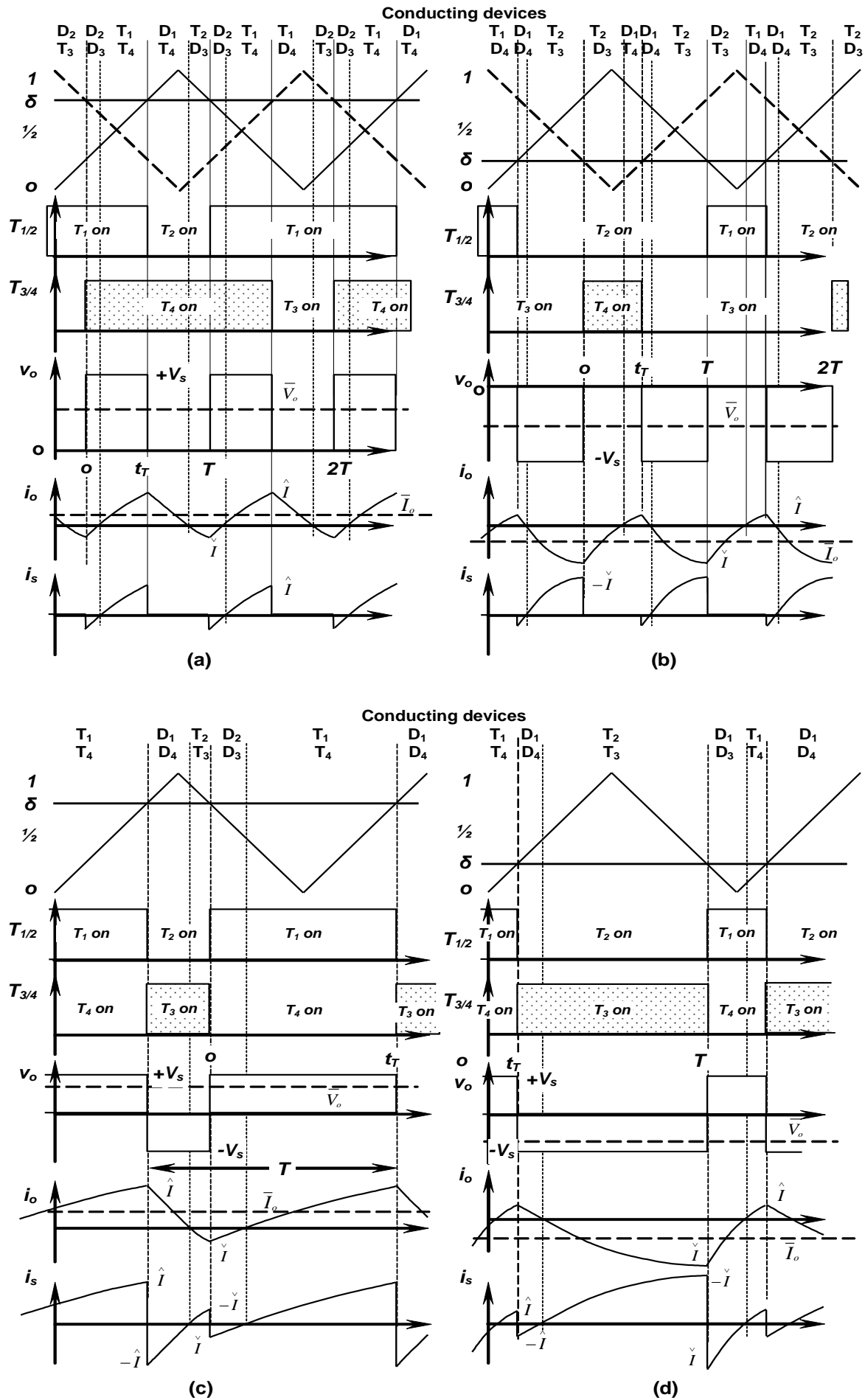

Figure 16.22. Four-quadrant dc chopper circuit waveforms: multilevel (three-level) output voltage (a) with $\bar{V}_o > 0$ and $\bar{I}_o > 0$; (b) with $\bar{V}_o < 0$ and $\bar{I}_o < 0$; bipolar (two-level) output voltage (c) with $\bar{V}_o > 0$ and $\bar{I}_o > 0$; (d) with $\bar{V}_o < 0$ and $\bar{I}_o < 0$.

Figures 16.22c and d show chopper output voltage and current waveforms for conditions of positive average voltage and current in part (c) and negative average voltage and current in part (d). Each part is shown with the current having a positive maximum value and a negative minimum value. Such a load current condition involves activation of all possible chopper conducting paths (sequences) as shown at the top of each part in figure 16.22 and transposed to table 16.3A. The table shows how the conducting device possibilities (states) decrease if the minimum value is positive or the maximum value is negative.

Table 16.3A: Four-quadrant chopper bipolar (two-level) output voltage states

| Conducting devices sequences | | | | | | | | |
|------------------------------|-------|-------|-------|--------------------------------|---------------|-------|-------|-------|
| $\bar{V} < 0$ | | | | | $\bar{V} > 0$ | | | |
| T_1 | D_1 | | | $\hat{I} > 0$ | T_1 | D_1 | | |
| T_4 | D_4 | | | | T_4 | D_4 | | |
| $\bar{V} < 0$ | | | | | $\bar{V} > 0$ | | | |
| T_1 | D_1 | T_2 | D_2 | $\hat{I} > 0$ $\hat{I} < 0$ | T_1 | D_1 | T_2 | D_2 |
| T_4 | D_4 | T_3 | D_3 | | T_4 | D_4 | T_3 | D_3 |
| $\bar{V} < 0$ | | | | | $\bar{V} > 0$ | | | |
| | | T_2 | D_2 | $\hat{I} < 0$ | | | T_2 | D_2 |
| | | T_3 | D_3 | | | | T_3 | D_3 |

If the minimum output current is positive, that is, \hat{I} is positive, then only components for a first and fourth quadrant chopper conduct. Specifically T_2 , T_3 , D_2 , and D_3 do not conduct. Examination of figure 16.22c shows that the output current conduction states are as shown in table 16.3A for $\hat{I} > 0$.

If the output current never goes positive, that is \hat{I} is negative, then T_1 , T_4 , D_1 , and D_4 do not conduct. The conducting sequence becomes as shown in table 16.3A for $\hat{I} < 0$. Because the output is bipolar ($\pm V_s$), the average chopper output voltage, \bar{V}_o does not affect the three possible steady state sequences. Table 16.3A shows that the conducting devices are independent of the average output voltage polarity. That is, the switch states are the same on the left and right sides of table 16.3A.

The transition between these three possible sequences, due to a current level polarity change, is seamless. The only restriction is that both switches in any leg do not conduct simultaneously. This is ensured by inserting a brief dead-time between a switch turning off and its leg complement being turned on. That is, dead-time between the switching of the complementary pair (T_1 - T_2), and in the other leg the complementary pair is (T_3 - T_4).

16.6.2 Unified four-quadrant dc chopper - multilevel voltage output switching

In order to generate three output states, specifically $\pm V_s$ and 0V, two triangular references are used which are displaced by 180° from one another as shown in figure 16.22a and b. One carrier triangle is used to specify the state of the leg formed by T_1 and T_2 (the complement of T_1), while the other carrier triangle specifies the state of leg formed by switches T_3 and T_4 , (the complement of T_3). The output voltage level switches between $+V_s$, 0V, and $-V_s$ depending on the modulation index δ , such that $0 \leq \delta \leq 1$. A characteristic of the output voltage is that, depending on δ , only a maximum of two of the three states appear in the output, in steady-state. The 0V state is always one of the two alternating states. An alternative method to generate the same switching waveforms, is to use one triangular carrier and two references, δ and $1-\delta$.

If $\delta = 0$ then T_1 and T_4 never turn-on since T_2 and T_3 conduct continuously which impresses $-V_s$ across the load. As δ increases from zero, the 0V state appears as well as the $-V_s$ state, the later of which decreases in duration as δ increases.

At $\delta = 1/2$ the output is zero since T_2 and T_3 (or T_1 and T_4) are never on simultaneously to provide a path involving the dc source. The output voltage is formed by alternating 0V loops (T_1 and T_3 on, alternating to T_2 and T_4 on, etc.). The average output voltage is therefore zero.

At the extreme $\delta = 1$, T_1 and T_4 are on continuously and V_s is impressed across the load. As δ is reduced from one, the 0V state is introduced, progressively lengthening to all of the period as δ reduces to $1/2$.

The voltage output in terms of the triangular level v_Δ reference is defined by

For $0 \leq \delta < 1/2$

- $v_\Delta > \delta, v_o = -V_s$
- $v_\Delta < \delta, v_o = 0$

For $\delta = 1/2$

- $v_\Delta > \delta, v_o = 0$
- $v_\Delta < \delta, v_o = 0$

For $1/2 > \delta \geq 1$

- $v_\Delta > \delta, v_o = 0$
- $v_\Delta < \delta, v_o = V_s$

From figure 16.22b for $\delta < 1/2$, the average output voltage varies linearly with δ such that

$$\begin{aligned}\bar{V}_o &= \frac{1}{T} \left(\int_0^{t_T} 0 dt + \int_{t_T}^T -V_s dt \right) \\ &= \frac{1}{T} (t_T - T) V_s = \left(\frac{t_T}{T} - 1 \right) V_s\end{aligned}\quad (16.115)$$

Examination of figure 16.22b reveals that the relationship between t_T and δ must produce

$$\text{when } \delta = 0: \quad t_T = 0 \text{ and } v_o = -V_s$$

$$\text{when } \delta = 1/2: \quad t_T = T \text{ and } v_o = 0$$

that is

$$\delta = 1/2 \frac{t_T}{T}$$

which on substituting for t_T/T in equation (16.115) gives

$$\begin{aligned}\bar{V}_o &= \left(\frac{t_T}{T} - 1 \right) V_s \\ &= (2\delta - 1) V_s\end{aligned}\quad (16.116)$$

From figure 16.22a for $\delta > 1/2$, the average output voltage varies linearly with δ such that

$$\begin{aligned}\bar{V}_o &= \frac{1}{T} \left(\int_0^{t_T} V_s dt + \int_{t_T}^T 0 dt \right) \\ &= V_s \frac{t_T}{T}\end{aligned}\quad (16.117)$$

Examination of figure 16.22a reveals that the relationship between t_T and δ must produce

$$\text{when } \delta = 1/2: \quad t_T = 0 \text{ and } v_o = 0$$

$$\text{when } \delta = 1: \quad t_T = T \text{ and } v_o = V_s$$

that is

$$\delta = 1/2 \left(\frac{t_T}{T} + 1 \right)$$

which on substituting for t_T/T in equation (16.117) gives

$$\bar{V}_o = (2\delta - 1) V_s \quad (16.118)$$

Alternately, if one pole produces δ then the other pole produces the complement, $1 - \delta$, such that the output is the difference, $\delta - (1 - \delta) = 2\delta - 1$.

Since the same expression results for $\delta \leq 1/2$ with bipolar switching, the average output current is the same for the range $0 \leq \delta \leq 1$, that is

$$\bar{I}_o = \frac{(\bar{V}_o - E)}{R} = \frac{((2\delta - 1)V_s - E)}{R} \quad (A) \quad (16.119)$$

which can be positive or negative, depending on δ and the load emf, E .

Although the average voltage equations of the multilevel and bipolar controlled dc choppers are the same, the rms voltage and ripple voltage differ, as does the peak-to-peak output ripple current. Unlike the bipolar controlled chopper, the rms voltage for the multilevel controlled chopper is not a single continuous function.

For $\delta \leq 1/2$ the rms load voltage is

$$\begin{aligned}V_{rms} &= \left[\frac{1}{T} \int_{t_T}^T (V_s)^2 dt \right]^{1/2} \\ &= \sqrt{1 - 2\delta} V_s\end{aligned}\quad (16.120)$$

The output ac ripple voltage is

$$\begin{aligned} V_r &= \sqrt{V_{rms}^2 - V_o^2} \\ &= \sqrt{(\sqrt{1-2\delta} V_s)^2 - ((2\delta-1)V_s)^2} \\ &= \sqrt{2} V_s \sqrt{\delta(1-2\delta)} \end{aligned} \quad (16.121)$$

The output voltage ripple factor is

$$\begin{aligned} RF &= \frac{V_r}{V_o} = \sqrt{\left(\frac{V_{rms}}{V_o}\right)^2 - 1} = \sqrt{FF^2 - 1} \\ &= \sqrt{2 \times \frac{\delta}{1-2\delta}} = \sqrt{\left(\frac{1}{1-2\delta}\right)^2 - 1} \end{aligned} \quad (16.122)$$

Thus as the duty cycle $\delta \rightarrow 0$, the ripple factor tends to zero, consistent with dc output voltage, that is $V_r = 0$. The ripple factor is undefined when the average output voltage is zero, at $\delta = \frac{1}{2}$.

The minimum rms ripple voltage in the output occurs when $\delta = \frac{1}{2}$ or 0 giving an rms ripple voltage of zero, since the average is a dc value at the extremes (0V and $-V_s$ respectively). The maximum ripple occurs at $\delta = \frac{3}{4}$, when $V_r = \frac{1}{2}V_s$, which is the same as when $\delta = \frac{3}{4}$, (but half that obtained with the bipolar output control method, V_s).

For $\delta \geq \frac{1}{2}$ the rms load voltage is

$$\begin{aligned} V_{rms} &= \left[\frac{1}{T} \int_{t_r}^T (-V_s)^2 dt \right]^{1/2} \\ &= \sqrt{2\delta-1} V_s \end{aligned} \quad (16.123)$$

The output ac ripple voltage is

$$\begin{aligned} V_r &= \sqrt{V_{rms}^2 - V_o^2} \\ &= \sqrt{(\sqrt{2\delta-1} V_s)^2 - ((2\delta-1)V_s)^2} = \sqrt{2} V_s \sqrt{(2\delta-1)(1-\delta)} \end{aligned} \quad (16.124)$$

The minimum rms ripple voltage in the output occurs when $\delta = \frac{1}{2}$ or 1 giving an rms ripple voltage of zero, since the average is a dc value at the extremes (0V and V_s respectively). The maximum ripple occurs at $\delta = \frac{3}{4}$, when $V_r = \frac{1}{2}V_s$, which is half that obtained with the bipolar output control method.

The output voltage ripple factor is

$$\begin{aligned} RF &= \frac{V_r}{V_o} = \sqrt{FF^2 - 1} = \sqrt{\left(\frac{V_{rms}}{V_o}\right)^2 - 1} \\ &= \sqrt{2 \times \frac{1-\delta}{2\delta-1}} = \sqrt{\left(\frac{1}{2\delta-1}\right)^2 - 1} \end{aligned} \quad (16.125)$$

Thus as the duty cycle $\delta \rightarrow 1$, the ripple factor tends to zero, consistent with the output being dc, that is $V_r = 0$. The ripple factor is undefined when the average output voltage is zero, at $\delta = \frac{1}{2}$.

Circuit operation is characterized by three time domain equations.

During the **on-period for T1 and T4**, when $v_o(t) = V_s$

$$L \frac{di_o}{dt} + R i_o + E = V_s$$

which yields

$$i_o(t) = \frac{V_s - E}{R} \left(1 - e^{-\frac{t}{\tau}}\right) + I e^{-\frac{t}{\tau}} \quad \text{for } 0 \leq t \leq t_r \text{ and } \delta \geq \frac{1}{2} \quad (16.126)$$

During the **on-period for T2 and T3**, when $v_o(t) = -V_s$

$$L \frac{di_o}{dt} + R i_o + E = -V_s$$

which, after shifting the zero time reference to t_r , gives

$$i_o(t) = -\frac{V_s + E}{R} \left(1 - e^{-\frac{t}{\tau}}\right) + I e^{-\frac{t}{\tau}} \quad \text{for } 0 \leq t \leq T - t_r \text{ and } \delta \leq \frac{1}{2} \quad (16.127)$$

The third equation is for a zero voltage loop.

During the **switch off-period**, when $v_o(t) = 0$

$$L \frac{di_o}{dt} + R i_o + E = 0$$

which, after shifting the zero time reference, in figure 16.22a or b, gives

$$i_o(t) = -\frac{E}{R} \left(1 - e^{-\frac{t}{\tau}} \right) + \hat{I} e^{-\frac{t}{\tau}}$$

$$0 \leq t \leq t_r \text{ and } \delta \leq 1/2 \tag{16.128}$$

$$0 \leq t \leq T - t_r \text{ and } \delta \geq 1/2$$

The initial conditions \hat{I} and \check{I} are determined by using the usual steady-state boundary condition method and are dependent on the transition states. For example, for continuous steady-state transitions between $+V_s$ loops and $0V$ loops, the boundary conditions are given by

$$\text{where } \hat{I} = \frac{V_s}{R} \frac{1 - e^{-\frac{t_r}{\tau}}}{1 - e^{-\frac{T}{\tau}}} - \frac{E}{R} \tag{A}$$

$$\text{and } \check{I} = \frac{V_s}{R} \frac{e^{\frac{t_r}{\tau}} - 1}{e^{\frac{T}{\tau}} - 1} - \frac{E}{R} \tag{A}$$

Figures 16.22a and b show output voltage and current waveforms for conditions of positive average voltage and current in part (a) and negative average voltage and current in part (b). Each part is shown with the current having a positive maximum value and a negative minimum value. Such a load current condition involves the activation of all possible chopper conducting paths, which are shown at the top of each part in figure 16.22 and transposed to table 16.3B. The conducting device possibilities decrease if the minimum value is positive or the maximum value is negative.

Table 16.3B: A Four-quadrant chopper multilevel (three-level) output voltage states

| Conducting devices sequences | | | | | | | | | | | | | | | | | | | | | | | | |
|------------------------------|----------------|----------------|----------------|----------------|----------------|----------------|----------------|----------------|----------------|----------------|----------------|-----------------|----------------|----------------|----------------|----------------|----------------|----------------|----------------|----------------|----------------|----------------|--|--|
| $\bar{V} > 0$ | | | | | | $\bar{V} < 0$ | | | | | | | | | | | | | | | | | | |
| | | T ₁ | D ₁ | | | | | T ₁ | T ₁ | | | $\check{I} > 0$ | T ₁ | D ₁ | | | D ₁ | D ₁ | | | | | | |
| | | T ₄ | T ₄ | | | | | T ₄ | D ₄ | | | | D ₄ | D ₄ | | | T ₄ | D ₄ | | | | | | |
| $\bar{V} > 0$ | | | | | | $\bar{V} < 0$ | | | | | | $\check{I} < 0$ | $\bar{V} > 0$ | | | | | | $\bar{V} < 0$ | | | | | |
| D ₂ | D ₂ | T ₁ | D ₁ | T ₂ | D ₂ | T ₁ | T ₁ | T ₁ | D ₁ | T ₂ | D ₂ | | T ₁ | T ₁ | T ₂ | D ₂ | T ₁ | T ₁ | T ₂ | D ₂ | T ₁ | T ₁ | | |
| T ₃ | D ₃ | T ₄ | T ₄ | D ₃ | D ₃ | T ₄ | D ₄ | D ₄ | D ₄ | T ₃ | D ₃ | T ₄ | D ₄ | T ₃ | T ₃ | | | | | | | | | |
| $\bar{V} > 0$ | | | | | | $\bar{V} < 0$ | | | | | | $\hat{I} < 0$ | $\bar{V} > 0$ | | | | | | $\bar{V} < 0$ | | | | | |
| D ₂ | D ₂ | | | T ₂ | D ₂ | | | | | T ₂ | D ₂ | | | | | | T ₂ | D ₂ | | | | | | |
| T ₃ | D ₃ | | | D ₃ | D ₃ | | | | | T ₃ | D ₃ | | | | | T ₃ | D ₃ | | | | | | | |

If the minimum output current is positive, that is, \check{I} is positive, then only components for a first and fourth quadrant chopper conduct. Specifically T₂, T₃, D₂, and D₃ do not conduct, thus do not appear in the output sequence. Examination of figure 16.22a shows that the output current conduction states are as shown in table 16.3B for $\check{I} > 0$.

If the output current never goes positive, that is \hat{I} is negative, then T₁, T₄, D₁, and D₄ do not conduct, thus do not appear in the output device sequence. The conducting sequence is as shown in table 16.3B for $\hat{I} < 0$.

Unlike the bipolar control method, the output sequence is affected by the average output voltage level, as well as the polarity of the output current swing. The transition between the six possible sequences due to load voltage and current polarity changes, is seamless. The only restriction is that both switching devices in any leg do not conduct simultaneously. This is ensured by inserting a brief dead-time between a switch turning off and its leg complement being turned on.

Example 16.7: Four-quadrant dc chopper

The H-bridge, dc-to-dc chopper in figure 16.21 feeds an inductive load of 10Ω resistance, 50mH inductance, and back emf of 55V dc, from a 340V dc source. If the chopper is operated with a 200Hz multilevel carrier as in figure 16.22 a and b, with a modulation depth of $\delta = 1/4$, determine:

- i. the average output voltage and switch T_1 on-time
- ii. the rms output voltage and ac ripple voltage, hence voltage ripple and form factors
- iii. the average output current, hence quadrant of operation
- iv. the electromagnetic power being extracted from the back emf E .

If the mean load current is to be halved, what is

- v. the modulation depth, δ , requirement
- vi. the average output voltage and the corresponding switch T_1 on-time
- vii. the electromagnetic power being extracted from the back emf E ?

Solution

The main circuit and operating parameters are

- modulation depth $\delta = 1/4$
- period $T_{\text{carrier}} = 1/f_{\text{carrier}} = 1/200\text{Hz} = 5\text{ms}$
- $E = 55\text{V}$ and $V_s = 340\text{V}$ dc
- load time constant $\tau = L/R = 0.05\text{mH}/10\Omega = 5\text{ms}$

- i. The average output voltage is given by equation (16.116), and for $\delta < 1/2$,

$$\begin{aligned}\bar{V}_o &= \left(\frac{t_T}{T} - 1\right)V_s = (2\delta - 1)V_s \\ &= 340\text{V} \times (2 \times 1/4 - 1) = -170\text{V}\end{aligned}$$

where

$$t_T = 2\delta T = 2 \times 1/4 \times (1/2 \times 5\text{ms}) = 1.25\text{ms}$$

Figure 16.22 reveals that the carrier frequency is half the switching frequency, thus the 5ms in the above equation has been halved. The switches T_1 and T_4 are turned on for 1.25ms , while T_2 and T_3 are subsequently turned on for 3.75ms .

- ii. The rms load voltage, from equation (16.120), is

$$\begin{aligned}V_{\text{rms}} &= \sqrt{1 - 2\delta} V_s \\ &= 340\text{V} \times \sqrt{1 - 2 \times 1/4} = 240\text{V rms}\end{aligned}$$

From equation (16.121), the output ac ripple voltage, hence voltage ripple factor, are

$$\begin{aligned}V_r &= \sqrt{2} V_s \sqrt{\delta(1 - 2\delta)} \\ &= \sqrt{2} \times 340\text{V} \times \sqrt{1/4 \times (1 - 2 \times 1/4)} = 170\text{V ac}\end{aligned}$$

$$RF = \frac{V_r}{\bar{V}_o} = \frac{170\text{V}}{|-170\text{V}|} = 1 \quad FF = \sqrt{RF^2 + 1} = \sqrt{2} = 1.41$$

- iii. The average output current is given by equation (16.119)

$$\begin{aligned}\bar{I}_o &= \frac{\bar{V}_o - E}{R} = \frac{(2\delta - 1)V_s - E}{R} \\ &= \frac{340\text{V} \times (2 \times 1/4 - 1) - 55\text{V}}{10\Omega} = -22.5\text{A}\end{aligned}$$

Since both the average output current and voltage are negative (-170V and -22.5A) the chopper with a modulation depth of $\delta = 1/4$, is operating in the third quadrant.

- iv. The electromagnetic power developed by the back emf E is given by

$$P_E = E\bar{I}_o = 55\text{V} \times (-22.5\text{A}) = -1237.5\text{W}$$

- v. The average output current is given by

$$\bar{I}_o = \frac{(\bar{V}_o - E)}{R} = \frac{((2\delta - 1)V_s - E)}{R}$$

when the mean current is -11.25A , $\delta = 0.415$, as derived in part vi.

vi. Then, if the average current is halved to -11.25A

$$\begin{aligned}\bar{V}_o &= E + \bar{I}_o R \\ &= 55\text{V} - 11.25\text{A} \times 10\Omega = -57.5\text{V}\end{aligned}$$

The average output voltage rearranged in terms of the modulation depth δ gives

$$\begin{aligned}\delta &= \frac{1}{2} \left(1 + \frac{\bar{V}_o}{V_s} \right) \\ &= \frac{1}{2} \times \left(1 + \frac{-57.5\text{V}}{340\text{V}} \right) = 0.415\end{aligned}$$

The switch on-time when $\delta < \frac{1}{2}$ is given by

$$t_T = 2\delta T = 2 \times 0.415 \times (1/2 \times 5\text{ms}) = 2.07\text{ms}$$

From figure 16.22b both T_1 and T_4 are turned on for 2.07ms, although, from table 16.3B, for negative load current, $\bar{I}_o = -11.25\text{A}$, the parallel connected freewheel diodes D_2 and D_3 conduct alternately, rather than the switches (assuming $\dot{I}_o < 0$). The switches T_1 and T_4 are turned on for 1.25ms, while T_2 and T_3 are subsequently turned on for 2.93ms.

vii. The electromagnetic power developed by the back emf E is halved and is given by

$$P_E = E\bar{I}_o = 55\text{V} \times (-11.25\text{A}) = -618.75\text{W}$$



Reading list

Dewan, S. B. and Straughen, A., *Power Semiconductor Circuits*,

John Wiley & Sons, New York, 1975.

Dubey, G.K., *Power Semiconductor Controlled Drives*,

Prentice-Hall International, 1989.

Mohan, N., Undeland, T. M., & Robbins, W.P., *Power Electronics: Converters, Applications & Design*,

John Wiley & Sons, New York, 2003.

Problems

16.1. The dc GTO thyristor chopper shown in figure 16.1c operates at 1kHz and supplies a series 5Ω and 10mH load from an 84V dc battery source. Derive general expressions for the mean load voltage and current, and the load rms voltage at an on-time duty cycle of δ . Evaluate these parameters for $\delta = 0.25$.

[21 V, 4.2 A; 42 V]

16.2. The dc chopper in figure 16.1c controls a load of $R = 10\Omega$, $L = 10\text{mH}$ and 40V battery. The supply is 340V dc and the chopping frequency is 5kHz . Calculate (a) the peak-to-peak load ripple current, (b) the average load current, (c) the rms load current, (d) the effective input resistance, and (e) the rms switch current.