

CHAPTER 15

AC Voltage Regulators

AC voltage regulators usually have a constant voltage ac supply input and incorporate semiconductor switches which vary the rms voltage impressed across the ac load. These regulators generally fall into the category of naturally commutating converters since their thyristor switches are naturally commutated by the alternating supply. This converter turn-off process is termed *line commutation*.

The regulator output current, hence supply current, may be discontinuous or non-sinusoidal and as a consequence input power factor correction and harmonic reduction are usually necessary, particularly at low output voltage levels (relative to the input ac voltage magnitude).

A feature of *direction conversion* of ac to ac is the absence of any intermediate energy stage, such as a capacitive dc link or energy storage inductor. Therefore ac to ac converters are potentially more efficient but usually involve a larger number of switching devices and output is lost if the input supply is temporarily lost.

There are three basic ac regulator categories, depending on the relationship between the input supply frequency f_s , which is usually assumed single frequency sinusoidal, possibly multi-phased, and the output frequency f_o . Without the use of transformers (or boost inductors), the output voltage rms magnitude $V_{o,rms}$ is less than or equal to the input voltage rms magnitude V_s , $V_{o,rms} \leq V_s$.

- output frequency increased, $f_o > f_s$, for example, the matrix converter
- output frequency decreased, $f_o < f_s$, for example, the cycloconverter
- output frequency fundamental = supply frequency, $f_o = f_s$, for example, a phase controller

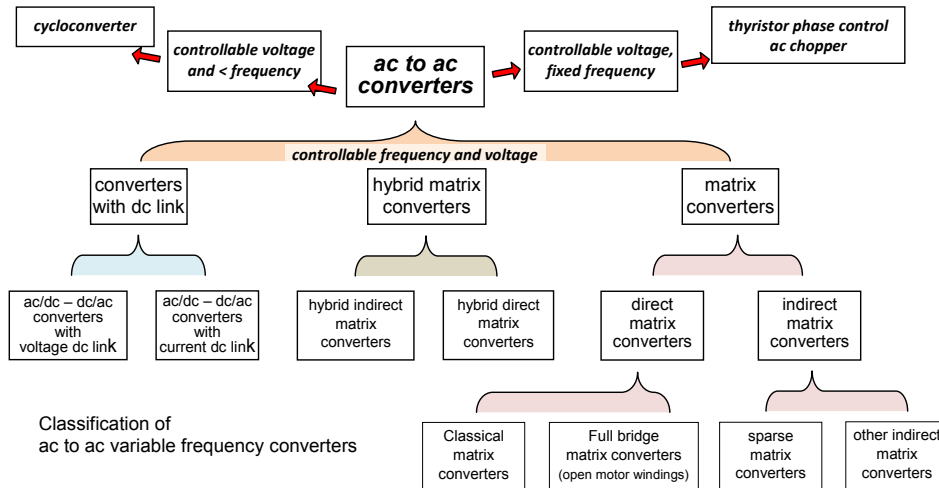

15.1 Single-phase ac regulator

Figure 15.1a shows a single-phase thyristor ac regulator supplying an L - R load. The two inverse parallel connected thyristors, possibly in the form of an ac output solid-state relay, SSR, can be replaced by any of the bidirectional conducting and blocking switch arrangements shown in figure 15.1c or figure 8.12. Equally, in low power applications the two thyristors are usually replaced by a triac.

The ac regulator in figure 15.1a can be controlled by two methods

- phase angle control – using symmetrical delay angles
- integral (or half integral) cycle control – using zero phase angle delay

15.1.1 Single-phase ac regulator – phase control with line commutation

For control by phase angle delay, the thyristor gate trigger delay angle is α , where $0 \leq \alpha \leq \pi$, as indicated in figure 15.1b. The fundamental of the output angular frequency is the same as the input angular frequency, $\omega = 2\pi f_s$. The thyristor current, shown in figure 15.1b, is defined by equation (14.42); that is

$$L \frac{di}{dt} + Ri \begin{cases} = \sqrt{2}V \sin \omega t & (\text{V}) & \alpha \leq \omega t \leq \beta & (\text{rad}) \\ = 0 & & \text{otherwise} & \end{cases} \quad (15.1)$$

There are two solutions to this first order differential equation, depending on the delay angle α relative to the load natural power factor angle, $\phi = \tan^{-1} \omega L/R$.

Because of symmetry, the mean (average) supply and load, voltages and currents, are zero.

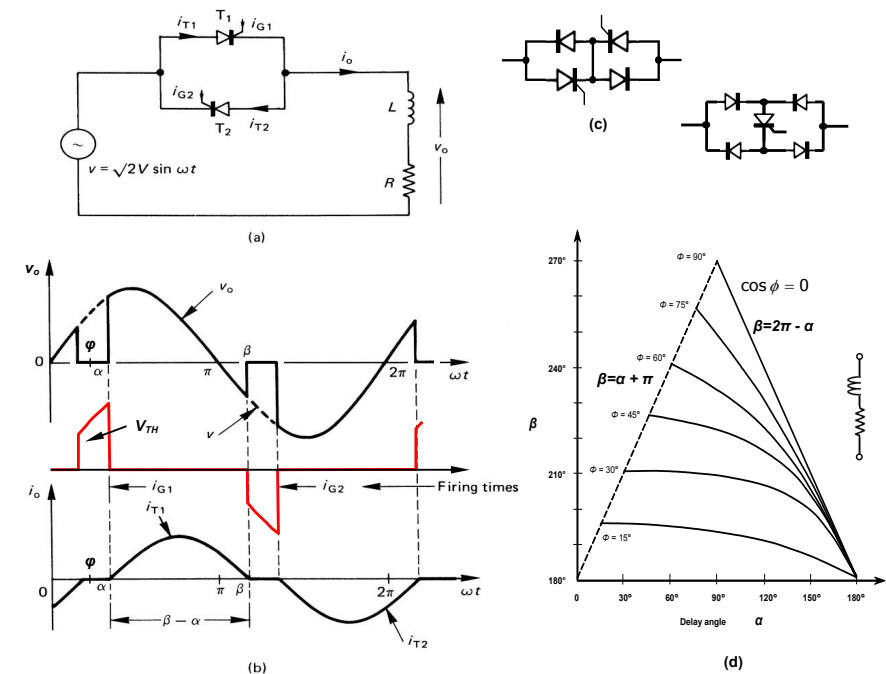

Figure 15.1. Single-phase full-wave symmetrical thyristor ac regulator with an R - L load: (a) circuit connection; (b) load current and voltage waveforms for $a > \phi$; (c) asymmetrical voltage blocking thyristor alternatives; and (d) current extinction angle β versus triggering delay angle α .

Case 1: $\alpha > \phi$

When the delay angle exceeds the load power factor angle the load current always reaches zero before $\pi + \phi$, thus the differential equation boundary conditions are zero. The solution for the current i is

$$i(\omega t) = \frac{\sqrt{2}V}{Z} \left\{ \sin(\omega t - \phi) - \sin(\alpha - \phi) e^{-at + \alpha/\tan \phi} \right\} \quad (\text{A}) \quad (15.2)$$

$$\alpha \leq \omega t \leq \beta \quad (\text{rad})$$

$$i(\omega t) = 0 \quad (\text{A}) \quad (15.3)$$

$$\pi \leq \beta \leq \omega t \leq \pi + \alpha \quad (\text{rad})$$

where $Z = \sqrt{R^2 + \omega^2 L^2}$ (ohms) and $\tan \phi = \omega L/R = Q$

Provided $\alpha > \phi$ both ac regulator thyristors will conduct and load current flows symmetrically as shown in figure 15.1b. The thyristor conduction period is given by the angle $\theta = \beta - \alpha$.

The thyristor current extinction angle β for discontinuous load current can be determined with the aid of figure 14.5a, but with the restriction that $\beta - \alpha \leq \pi$, or figure 15.1d, or by solving equation 14.44, that is:

$$\sin(\beta - \phi) = \sin(\alpha - \phi) e^{(\alpha - \beta) \tan \phi} \quad (15.4)$$

From figure 15.1b the rms output voltage is

$$\begin{aligned} V_{rms} &= \left[\frac{1}{\pi} \int_{\alpha}^{\beta} (\sqrt{2}V)^2 \sin^2 \omega t \, d\omega t \right]^{1/2} = \sqrt{2}V \left[\frac{1}{\pi} \int_{\alpha}^{\beta} (1 - \cos 2\omega t) \, d\omega t \right]^{1/2} \\ &= V \left[\frac{1}{\pi} \left\{ (\beta - \alpha) - \frac{1}{2}(\sin 2\beta - \sin 2\alpha) \right\} \right]^{1/2} = V \left[\frac{1}{\pi} \left\{ (\beta - \alpha) - \sin(\beta - \alpha) \cos(\alpha + \beta) \right\} \right]^{1/2} \end{aligned} \quad (15.5)$$

The maximum rms output voltage is when $\alpha = \Phi$ and $\beta = \Phi + \pi$ in equation (15.5), giving $\hat{V}_{rms} = V$.

The rms load current is found by the appropriate integration of equation (15.2) squared, namely

$$\begin{aligned} I_{rms} &= \left[\frac{1}{\pi} \int_{\alpha}^{\beta} \left(\frac{\sqrt{2}V}{Z} \right)^2 \left\{ \sin(\omega t - \phi) - \sin(\alpha - \phi) e^{-\omega t + \alpha / \tan \phi} \right\}^2 \, d\omega t \right]^{1/2} \\ &= \frac{V}{Z} \left[\frac{1}{\pi} \left\{ (\beta - \alpha) - \frac{\sin(\beta - \alpha)}{\cos \phi} \cos(\beta + \alpha + \phi) \right\} \right]^{1/2} \end{aligned} \quad (15.6)$$

The maximum rms output current is when $\alpha = \Phi$ in equation (15.6), giving $\hat{I}_{rms} = V/Z$.

From equation (15.6), the thyristor rms current is given by $I_{Th_{rms}} = I_{rms} / \sqrt{2}$ and is a maximum when $\alpha \leq \phi$, that is

$$\hat{I}_{Th_{rms}} = \frac{\hat{I}_{rms}}{\sqrt{2}} = \frac{V}{\sqrt{2}Z} \quad (15.7)$$

Using the fact that the average voltage across the load inductor is zero, the rectified mean voltage (hence current) can be used to determine the thyristor mean current rating.

$$\begin{aligned} \bar{V}_o &= \bar{I}_o R = \frac{1}{\pi} \int_{\alpha}^{\beta} \sqrt{2}V \sin \omega t \, d\omega t \\ &= \sqrt{2}V \left[\frac{1}{\pi} (\cos \alpha - \cos \beta) \right] \quad (V) \end{aligned} \quad (15.8)$$

The mean thyristor current $\bar{I}_{Th} = \frac{1}{2} \bar{I}_o = \frac{1}{2} \bar{V}_o / R$, that is

$$\bar{I}_{Th} = \frac{\frac{1}{2} \bar{V}_o}{R} = \frac{\sqrt{2}V}{2R} \left[\frac{1}{\pi} (\cos \alpha - \cos \beta) \right] \quad (A) \quad (15.9)$$

The maximum mean thyristor current is for a load $\alpha = \phi$ and $\beta = \pi + \phi$, that is

$$\hat{\bar{I}}_{Th} = \frac{\sqrt{2}V \cos \phi}{\pi R} = \frac{\sqrt{2}V}{\pi Z} \quad (15.10)$$

The thyristor forward and reverse voltage blocking ratings are both $\sqrt{2}V$.

The load current form factor, using $\cos \Phi = R/Z$, is

$$\begin{aligned} FF_{load} &= \frac{I_{rms}}{\bar{I}_o} \\ &= \frac{\cos \phi \left[\frac{1}{\pi} \left\{ (\beta - \alpha) - \frac{\sin(\beta - \alpha)}{\cos \phi} \cos(\beta + \alpha + \phi) \right\} \right]^{1/2}}{\sqrt{2} \left[\frac{1}{\pi} (\cos \alpha - \cos \beta) \right]} \end{aligned} \quad (15.11)$$

which is a maximum when $\alpha = \Phi$, giving $\hat{FF}_{load} = \pi / 2\sqrt{2}$.

The thyristor current form factor is $FF_{Th} = \sqrt{2} FF_{load}$, which is a maximum when $\alpha = \Phi$, $\hat{FF}_{Th} = \frac{1}{2}\pi$.

The load power is

$$\begin{aligned} P_o &= I_{rms}^2 R \\ &= \frac{(V \cos \phi)^2}{R} \left[\frac{\beta - \alpha}{\pi} - \frac{\sin(\beta - \alpha)}{\pi \cos \phi} \cos(\alpha + \phi + \beta) \right] \end{aligned} \quad (15.12)$$

which is a maximum when $\alpha = \Phi$, giving $\hat{P}_o = \frac{V^2}{Z} \cos \phi = \left(\frac{V}{Z} \right)^2 R$.

The supply power factor is

$$\begin{aligned} pf &= \frac{P_o}{V I_{rms}} \\ &= \left[\frac{\beta - \alpha}{\pi} - \frac{\sin(\beta - \alpha)}{\pi \cos \phi} \cos(\alpha + \phi + \beta) \right]^{1/2} \times \cos \phi \end{aligned} \quad (15.13)$$

which is a maximum when $\alpha = \Phi$, giving $\hat{pf} = \cos \phi$.

For an inductive L - R load, the fundamental load voltage components (cos and sin respectively) are

$$a_1 = \frac{\sqrt{2}V}{2\pi} (\cos 2\alpha - \cos 2\beta) \quad (15.14)$$

$$b_1 = \frac{\sqrt{2}V}{2\pi} (2(\beta - \alpha) - (\sin 2\beta - \sin 2\alpha))$$

$$a_n = \frac{\sqrt{2}V}{\pi} \left[\frac{\cos(n+1)\alpha - \cos(n+1)\beta}{n+1} - \frac{\cos(n-1)\alpha - \cos(n-1)\beta}{n-1} \right] \quad (15.15)$$

$$b_n = \frac{\sqrt{2}V}{\pi} \left[\frac{\sin(n+1)\alpha - \sin(n+1)\beta}{n+1} - \frac{\sin(n-1)\alpha - \sin(n-1)\beta}{n-1} \right]$$

for $n = 3, 5, 7, \dots$ odd.

The Fourier component magnitudes and phases are given by

$$c_n = \sqrt{a_n^2 + b_n^2} \quad \text{and} \quad \phi_n = \tan^{-1} \frac{a_n}{b_n} \quad (15.16)$$

If $\alpha = \phi$, then continuous ac load current flows, and equation (15.14) reduces to $a_1 = 0$ and $b_1 = \sqrt{2}V$, when $\beta = \alpha + \pi = \Phi + \alpha$ and $\alpha = \phi$ are substituted.

The supply apparent power can be grouped into a component at the fundamental frequency plus components at the harmonic frequencies.

$$\begin{aligned} S^2 &= V^2 I_1^2 + V^2 I_3^2 + V^2 I_5^2 + \dots \\ &= V^2 I_1^2 + V^2 I_3^2 + V^2 I_5^2 + \dots - V^2 I_1^2 \\ &= V^2 I_1^2 + V^2 I_{rms}^2 - V^2 I_1^2 \\ &= V^2 I_1^2 + V^2 (I_{rms}^2 - I_1^2) \\ &= S_1^2 + D^2 \\ &= P^2 + Q_1^2 + D^2 \end{aligned} \quad (15.17)$$

$$S^2 = (VI_1 \cos \phi_1)^2 + (VI_1 \sin \phi_1)^2 + D^2$$

where D is the supply current distortion due to the harmonic currents.

The current harmonic components are found by dividing the load Fourier voltage components by the load impedance at that frequency. Equation (15.16) gives the current harmonic angles ϕ_n and magnitudes according to

$$I_n = \frac{V_n}{Z_n} = \frac{V_n}{\sqrt{R^2 + \omega^2 L^2}} = \frac{c_n / \sqrt{2}}{\sqrt{R^2 + \omega^2 L^2}} \quad (15.18)$$

Case 2: $\alpha \leq \phi$ (continuous gate pulses)

When $\alpha \leq \phi$, a pure sinusoidal load current flows, and substitution of $\alpha = \phi$ in equation (15.2) results in

$$i(\omega t) = \frac{\sqrt{2}V}{Z} \sin(\omega t - \phi) \quad (A) \quad \alpha \leq \phi \quad (\text{rad}) \quad (15.19)$$

If a short duration gate trigger pulse is used and $\alpha < \phi$, unidirectional load current may result. The device to be turned on is reverse-biased by the conducting device. Thus if the gate pulse ceases before the previous half-cycle load current has fallen to zero, only one device conducts. It is therefore usual to employ a continuous gate pulse, or stream of pulses, from α until π , then for $\alpha < \phi$ a displaced sine wave output current results.

For both delay angle conditions, equations (15.5) to (15.14) are valid, except the simplification $\beta = \alpha + \pi$ is used when $\alpha \leq \phi$, which gives the maximum values for those equations. That is, for $\alpha \leq \phi$, substituting $\alpha = \phi$

$$\hat{V}_{rms} = V_{rms} = V \quad \hat{I}_{rms} = I_{rms} = V/Z \quad \hat{I}_{Th\ rms} = I_{Th\ rms} = V/\sqrt{2}Z \quad (15.20)$$

$$\hat{FF}_{Load} = FF_{Load} = \pi/2\sqrt{2} \quad \hat{P}_o = P_o = I_{rms}^2 R = V^2 \cos \phi / Z \quad \hat{p}f = pf = \cos \phi \quad \hat{I}_{Th} = \sqrt{2}V / \pi Z$$

15.1.1i - Resistive load

For a purely resistive load, the load voltage and current are related according to

$$i_o(\omega t) = \frac{v_o(\omega t)}{R} = \begin{cases} \sqrt{2}V \sin \omega t / R & \alpha \leq \omega t \leq \pi, \quad \alpha + \pi \leq \omega t \leq 2\pi \\ 0 & \text{otherwise} \end{cases} \quad (15.21)$$

The equations (15.1) to (15.20) can be simplified if the load is purely resistive. Continuous output current only flows for $\alpha = 0$, since $\phi = \tan^{-1} 0 = 0^\circ$. Therefore the output equations are derived from the discontinuous equations (15.2) to (15.14), with $\phi = 0$.

The average output voltage and current are zero. The mean half-cycle output voltage, used to determine thyristor mean current rating, is found by integrating the supply voltage over the interval α to π , ($\beta = \pi$).

$$\begin{aligned} V_o &= \frac{1}{\pi} \int_{\alpha}^{\pi} \sqrt{2}V \sin \omega t \, d\omega t \\ &= \frac{\sqrt{2}V}{\pi} (1 + \cos \alpha) \quad (V) \end{aligned} \quad (15.22)$$

$$\text{whence } \bar{I}_o = \frac{V_o}{R} = \frac{\sqrt{2}V}{\pi R} (1 + \cos \alpha) = 2\bar{I}_T \quad (A)$$

The average thyristor current is $\bar{I}_T = \frac{1}{2}\bar{I}_o$, which has a maximum value of $\hat{I}_T = \sqrt{2}V / \pi R$ when $\alpha = 0$.

From equation (15.5) the rms output voltage for a delay angle α is

$$\begin{aligned} V_{rms} &= \sqrt{\frac{1}{\pi} \int_{\alpha}^{\pi} (\sqrt{2}V \sin \omega t)^2 \, d\omega t} \\ &= V \sqrt{\frac{2(\pi - \alpha) + \sin 2\alpha}{2\pi}} \quad (V) \end{aligned} \quad (15.23)$$

which has a maximum of $\hat{V}_{rms} = V$ when $\alpha = 0$.

The rms output current and supply current from $I_{rms} = V_{rms} / R$ is

$$I_{rms} = \frac{V_{rms}}{R} = \frac{V}{R} \sqrt{1 - \frac{2\alpha - \sin 2\alpha}{2\pi}} = \sqrt{2} I_{T\ rms} \quad (A) \quad (15.24)$$

$$\text{and } I_{T\ rms} = I_{rms} / \sqrt{2}$$

The maximum rms supply current is $I_{rms} = V / R$ at $\alpha = 0$ when the maximum rms thyristor current is

$$\hat{I}_{T\ rms} = \hat{I}_{rms} / \sqrt{2} = V / \sqrt{2}R.$$

Therefore the output power, with $V_{rms} = R I_{rms}$, for a resistive load, is

$$P_o = I_{rms}^2 R = \frac{V_{rms}^2}{R} = \frac{V^2}{R} \left\{ 1 - \frac{2\alpha - \sin 2\alpha}{2\pi} \right\} \quad (W) \quad (15.25)$$

The input power is $P_{in} = VI_1 \cos \phi_1 (= P_{out})$.

The supply power factor λ is defined as the ratio of the real power to the apparent power, that is

$$pf = \lambda = \frac{P_o}{S} = \frac{V_{rms} I}{VI} = \frac{V_{rms}}{V} = \sqrt{\frac{2(\pi - \alpha) + \sin 2\alpha}{2\pi}} \quad (15.26)$$

where the apparent power is

$$S = VI_{rms} = \frac{V^2}{R} \left[1 - \frac{\alpha}{\pi} + \frac{\sin 2\alpha}{2\pi} \right] \quad (15.27)$$

and $Q = \sqrt{S^2 - P^2}$. The fundamental reactive power is

$$Q_1 = \frac{V^2 \cos 2\alpha - 1}{R \cdot 2\pi} \quad (15.28)$$

The thyristor current (and voltage for a resistive load) form factor (rms to mean), shown in figure 15.2, is

$$FF_{Th} = \frac{I_{Th\ rms}}{\bar{I}_{Th}} = \frac{\left[\pi(\pi - \alpha + \frac{1}{2} \sin 2\alpha) \right]^{1/2}}{1 + \cos \alpha} \quad (15.29)$$

From equation (15.165), the thyristor current crest factor is

$$\delta = \frac{\hat{I}_T}{\bar{I}_T} = \begin{cases} \frac{2\pi}{1 + \cos \alpha} & 0 \leq \alpha \leq \frac{1}{2}\pi \\ \frac{2\pi \sin \alpha}{1 + \cos \alpha} & \frac{1}{2}\pi \leq \alpha \leq \pi \end{cases} \quad (15.30)$$

The Fourier voltage components for a resistive load (with $\beta = \pi$ in equations (15.14) and (15.15)) are

$$\begin{aligned} a_1 &= \frac{\sqrt{2}V}{\pi} (\frac{1}{2} \cos 2\alpha - \frac{1}{2}) & b_1 &= \frac{\sqrt{2}V}{\pi} (\pi - \alpha + \frac{1}{2} \sin 2\alpha) \\ a_n &= \frac{\sqrt{2}V}{\pi} \left(\frac{\cos(n+1)\alpha - 1}{n+1} - \frac{\cos(n-1)\alpha - 1}{n-1} \right) & b_n &= \frac{\sqrt{2}V}{\pi} \left(\frac{\sin(n+1)\alpha}{n+1} - \frac{\sin(n-1)\alpha}{n-1} \right) \end{aligned} \quad (15.31)$$

for $n = 3, 5, 7, \dots$ odd. Figure 15.2 shows the relative harmonic rms magnitudes and dependence on α . The load current harmonics are found by dividing the voltage components by R , since $i(\omega t) = v(\omega t)/R$.

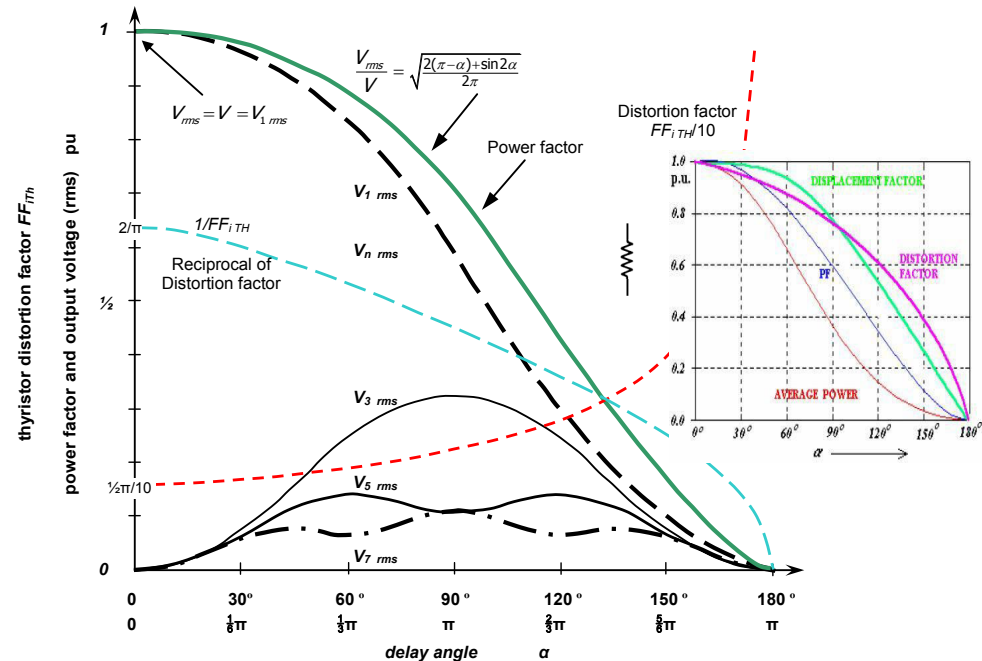

Figure 15.2. Normalised RMS harmonics (voltage and current) for a single-phase full-wave ac regulator with a pure resistive load.

The fundamental supply current is

$$i_{s1} = \frac{V_{o1}}{R} = \frac{1}{R} [b_1 \sin \omega t + a_1 \cos \omega t]$$

$$i_{s1} = \frac{\sqrt{2}V}{\pi R} \left[(\pi - \alpha + \frac{1}{2} \sin 2\alpha) \sin \omega t - (\frac{1}{2} \cos 2\alpha - \frac{1}{2}) \cos \omega t \right] \quad (15.32)$$

which has an rms value of

$$I_{s1} = \frac{V}{2\pi R} \left[(\cos 2\alpha - 1)^2 + (2\pi - 2\alpha + \sin 2\alpha)^2 \right]^{1/2} \quad (15.33)$$

When the power factor λ in equation (15.26) can be expressed in terms of the distortion factor and displacement factor, that is

$$\lambda = \frac{\text{average power}}{\text{apparent VA}} = \frac{P}{V I_{rms}} = \frac{V i_{s1} \cos \phi_1}{V I_{rms}} = \frac{i_{s1}}{I_{rms}} \cos \phi_1 = \text{distortion factor} \times \text{displacement factor}$$

The current distortion factor is equation (15.33) divided by equation (15.24), while the fundamental current displacement factor from the fundamental components in equation (15.31) yields

$$\text{displacement factor} = \cos \phi_1 \text{ where } \phi_1 = \tan^{-1} \frac{a_1}{b_1}$$

If the thyristors are modelled by

$$v_{TH} = v_o + i \times r_o$$

Then the thyristor losses are given by

$$P_{TH} = v_o \bar{I}_{Th} + r_o \times I_{Th,rms}^2 = v_o \bar{I}_{Th} + r_o \times \bar{I}_{Th}^2 \times FF_{iTh}(\alpha) \quad (W) \quad (15.34)$$

15.1.1ii - Pure inductive load

For a purely inductive load, the load power factor angle is $\phi = \frac{1}{2}\pi$. Since the inductor voltage average is zero, current conduction will be symmetrical about π . Thus equations (15.2) to (15.14) apply except they can be simplified since $\beta = 2\pi - \alpha$. These bounds imply that the delay angle should be greater than $\frac{1}{2}\pi$, but less than π . Therefore, if the delay angle is less than $\frac{1}{2}\pi$, conduction extends into the next half cycle, and with short gate pulses, preventing the reverse direction thyristor from conducting, as shown in figure 15.3c. The output is then a series of half-wave rectified current pulses as with the case $\alpha \leq \phi$ considered in 15.3iii. For the purely inductive load case, the equations and waveforms for the half-wave controlled rectifier in section 14.3.1ii, apply. Kirchhoff's voltage law gives

$$L \frac{di}{dt} = \sqrt{2} V \sin \omega t \quad (15.35)$$

The load current is given by:

$$i(\omega t) = \frac{\sqrt{2} V}{\omega L} (\cos \alpha - \cos \omega t) \quad \alpha \leq \omega t \leq 2\pi - \alpha \quad (15.36)$$

The current waveform is symmetrical about π .

$\alpha < \frac{1}{2}\pi$

i. **short** gate pulse period

With a purely inductive load, the average output voltage is zero. If uni-directional current flows (due to the uses of a narrow gate pulse), as shown in figure 15.3c, the average load current, hence average thyristor current, for the conducting thyristor, is

$$\begin{aligned} \bar{I}_o = \bar{I}_T &= \frac{1}{2\pi} \int_{\alpha}^{2\pi-\alpha} \frac{\sqrt{2} V}{\omega L} \{ \cos \alpha - \cos \omega t \} d\omega t \\ &= \frac{\sqrt{2} V}{\pi \omega L} [(\pi - \alpha) \cos \alpha + \sin \alpha] \end{aligned} \quad (15.37)$$

which with uni-polar pulses has a maximum of $\sqrt{2} V/\omega L$ at $\alpha = 0$.

The rectified average load voltage is

$$V_o = \frac{\sqrt{2} V}{\pi} (1 + \cos \alpha) \quad 0 \leq \alpha \leq \frac{1}{2}\pi \quad (15.38)$$

The rms load and supply (and one thyristor) current is

$$\begin{aligned} I_{ms} &= \frac{\sqrt{2} V}{\omega L} \left[\frac{1}{2\pi} \int_{\alpha}^{2\pi-\alpha} (\cos \alpha - \cos \omega t)^2 d\omega t \right]^{1/2} \\ &= \frac{V}{X} \left[\frac{1}{\pi} \left((\pi - \alpha)(2 + \cos 2\alpha) + \frac{3}{2} \sin 2\alpha \right) \right]^{1/2} \end{aligned} \quad (15.39)$$

The thyristor current form factor is

$$FF_{iT} = \frac{\frac{1}{2\pi} (\pi - \alpha)(2 + \cos 2\alpha) + \frac{3}{2} \sin 2\alpha}{\sin \alpha + (\pi - \alpha) \cos \alpha} \quad (15.40)$$

which has a maximum value of $\frac{1}{2}\pi$ when $\alpha = \frac{1}{2}\pi$.

The rms load voltage is

$$\begin{aligned} V_{rms} &= \left[\frac{1}{2\pi} \int_{\alpha}^{2\pi-\alpha} (\sqrt{2} V)^2 \sin^2 \omega t d\omega t \right]^{1/2} \\ &= V \left[\frac{1}{\pi} \{ (\pi - \alpha) + \frac{1}{2} \sin 2\alpha \} \right]^{1/2} \end{aligned} \quad (15.41)$$

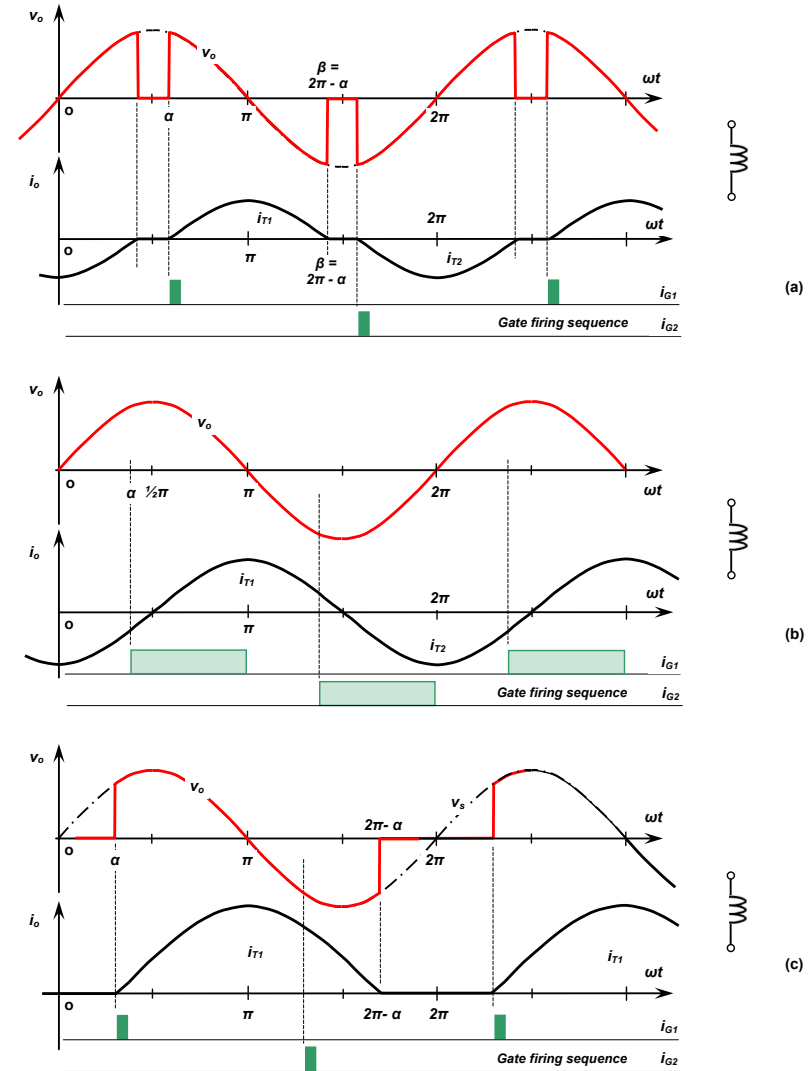

Figure 15.3. Single-phase full-wave thyristor ac regulator with a pure inductor load: (a) $\alpha > \frac{1}{2}\pi$; (b) $\alpha < \frac{1}{2}\pi$, gate pulse until π ; and (c) $\alpha < \frac{1}{2}\pi$, short gate pulse.

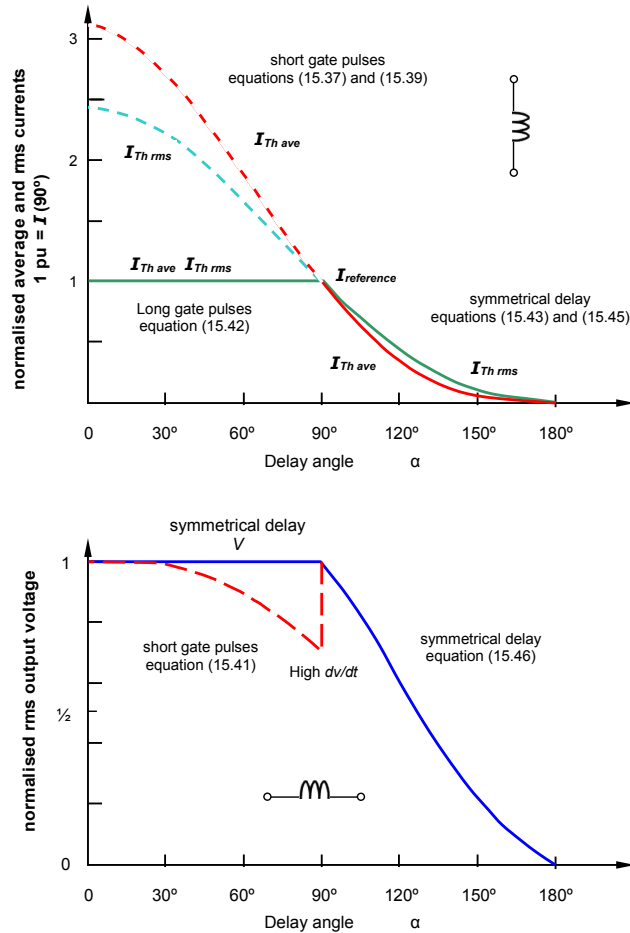

Figure 15.4. Normalised ac-chopper purely inductive load control characteristics of: (a) thyristor average and rms currents and (b) rectified average output voltage.

ii. extended gate pulse period

When the gate pulses are extended to π , continuous current flows, as shown in figure 15.3b, given by $I_{rms} = V/\omega L$, lagging V by $\frac{1}{2}\pi$. Each thyristor conducts an average current and rms current of

$$\begin{aligned} \bar{I}_T &= \frac{\sqrt{2}V}{\pi\omega L} \\ I_{Th\ rms} &= \frac{I_{rms}}{\sqrt{2}} = \frac{V}{\pi\omega L} \end{aligned} \quad (15.42)$$

$\pi \geq \alpha \geq \frac{1}{2}\pi$ (symmetrical gate pulses)

The output voltage and current are symmetrical, as shown in figure 15.3a, hence the average output voltage and current are both zero, as is the average input current. The average thyristor current is given by

$$\begin{aligned} \bar{I}_T &= \frac{1}{2\pi} \int_{\alpha}^{2\pi-\alpha} \frac{\sqrt{2}V}{\omega L} \{ \cos \alpha - \cos \omega t \} d\omega t \\ &= \frac{\sqrt{2}V}{\pi\omega L} [(\pi - \alpha) \cos \alpha + \sin \alpha] \end{aligned} \quad (15.43)$$

which has a maximum of $\sqrt{2}V/\pi\omega L$ at $\alpha = \frac{1}{2}\pi$.

The rectified average load voltage over half a cycle is

$$V_o = \frac{2\sqrt{2}V}{\pi} (1 + \cos \alpha) \quad (15.44)$$

The rms load and supply current is

$$\begin{aligned} I_{rms} &= \sqrt{2}I_{Th\ rms} = \frac{V}{\omega L} \left[\frac{2}{\pi} \int_{\alpha}^{2\pi-\alpha} (\cos \alpha - \cos \omega t)^2 d\omega t \right]^{1/2} \\ &= \frac{V}{X} \left[\frac{2}{\pi} \left((\pi - \alpha)(2 + \cos 2\alpha) + \frac{3}{2} \sin 2\alpha \right) \right]^{1/2} \end{aligned} \quad (15.45)$$

The rms load voltage is

$$\begin{aligned} V_{rms} &= \left[\frac{1}{\pi} \int_{\alpha}^{2\pi-\alpha} (\sqrt{2}V)^2 \sin^2 \omega t d\omega t \right]^{1/2} \\ &= V \left[\frac{2}{\pi} \left((\pi - \alpha) + \frac{1}{2} \sin 2\alpha \right) \right]^{1/2} \end{aligned} \quad (15.46)$$

The maximum rms voltage and current are $\hat{V}_{rms} = V$ and $\hat{I}_{rms} = V/X$ at $\alpha = \frac{1}{2}\pi$.

The rms equations for α greater than and less than $\frac{1}{2}\pi$ are basically the same except the maximum period over which a given thyristor conducts changes from π to 2π (respectively), hence the rms values differ by $\sqrt{2}$. Since the output power is zero, the supply power factor is zero, for bidirectional current.

If the controller in figure 15.1a is used in the half-controlled mode (thyristor and anti-parallel diode), the resultant dc component precludes its use in ac transformer applications. Such a controller is limited to low power ac applications because of dc restrictions on the ac mains supply.

15.1.iii - Load sinusoidal back emf

When the ac controller load comprises an ac back emf v_{bac} of the same frequency as the ac supply v , as with embedded generation, then, when the thyristors conduct, the load effectively sees the vector difference between the two ac voltages, $v - v_{bac}$, as shown in figure 15.5.

$$\begin{aligned} V_{R,L} &= V - V_{bac} \\ &= V \angle 0 - V_{bac} \angle \psi = V + 0j - V_{bac} (\cos \psi + j \sin \psi) \\ &= V - V_{bac} \cos \psi - jV_{bac} \sin \psi \\ &= V_{R,L} \angle \varphi \end{aligned} \quad (15.47)$$

where

$$\begin{aligned} V_{R,L} &= \sqrt{(V - V_{bac} \cos \psi)^2 + (V_{bac} \sin \psi)^2} = \sqrt{V^2 + V_{bac}^2 - 2V V_{bac} \cos \psi} \\ \varphi &= \tan^{-1} \frac{-V_{bac} \sin \psi}{V - V_{bac} \cos \psi} \end{aligned} \quad (15.48)$$

The passive part of the load can now be analysed as in sections 15.1.1i and ii, but the thyristor phase triggering delay angles are shifted by φ with respect to the original ac supply reference, as shown in the phasor diagrams in figure 15.5.

If the voltage is normalised with respect to the ac supply V , then the normalised curves in figure 15.5 can be used to obtain the phase angle φ , with respect to the ac mains reference. Therefore curves give the angle of the voltage (and the current in the case of a resistor load) across the passive part of the load.

As seen in the waveforms in figure 15.5, the load current is dependent on the relative magnitudes and angle between the two ac sources, the type of load, and the thyristor phase delay angle. Performance features with a resistive load and inductive load are illustrated in Example 15.1d.

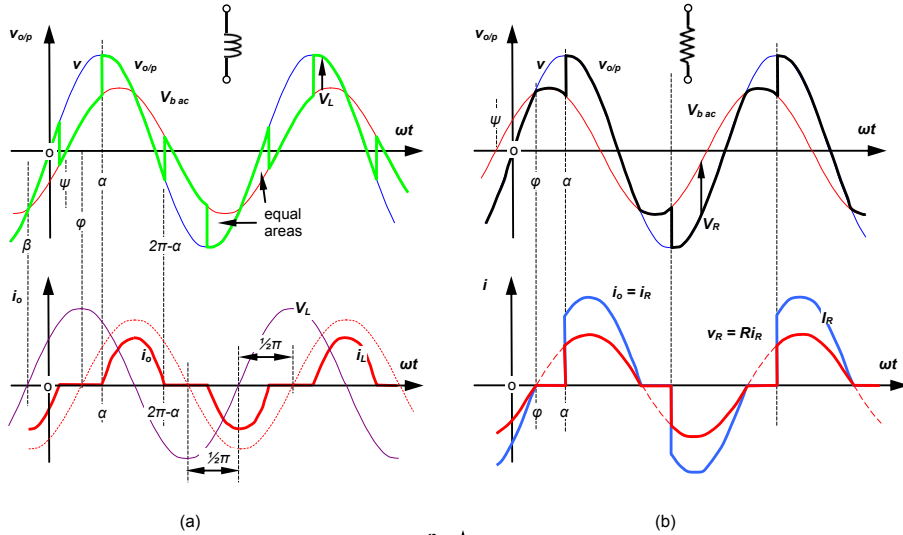
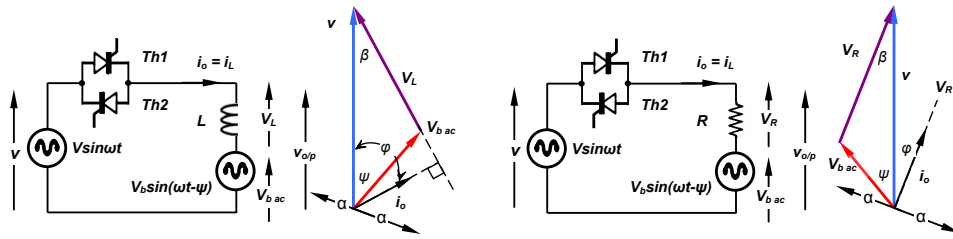

(a)

(b)

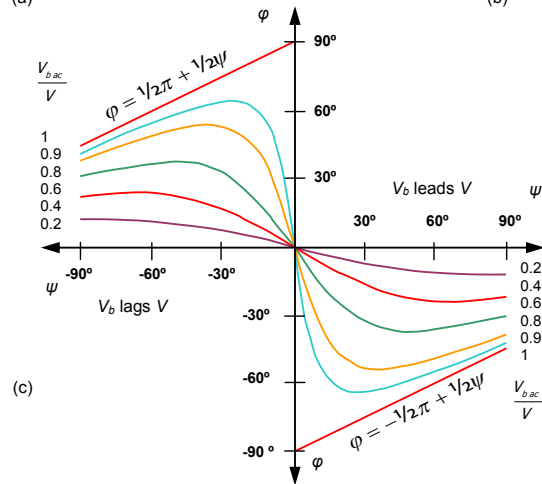

(c)

Figure 15.5. AC-chopper characteristics with ac back emf and purely resistive or inductive load. Circuit, phasor diagram and circuit waveforms for: (a) purely resistive and ac source load and (b) purely inductive and ac source load. (c) Phase displacement of resultant voltage of an ac emf opposing the ac mains.

15.1.1iv - Semi-controlled single-phase ac regulator

A semi-controlled single-phase ac regulator is formed by replacing one thyristor in figure 15.1a with a diode. A dc component results in the load current and voltage. For a resistive load, the diode average and rms currents are found by substituting $\alpha = 0$ in equations (15.22) and (15.24). Using these equations, the load resistance average and rms currents (hence voltages) are

$$\bar{I}_R = \bar{I}_D - \bar{I}_T = \frac{2\sqrt{2}}{\pi R} - \frac{2\sqrt{2}}{\pi R} (1 + \cos \alpha) = \frac{2\sqrt{2}}{\pi R} (1 - \cos \alpha) = \frac{V_o}{R} \tag{15.49}$$

$$I_{R,rms} = \sqrt{I_{D,rms}^2 + I_{T,rms}^2} = \frac{V}{2R} \left[\frac{2\alpha - \sin 2\alpha}{\pi} \right]^{1/2} = \frac{V_{rms}}{R}$$

The power dissipated in the resistive load is

$$P_R = \frac{V^2}{R} \left[\frac{2\alpha - \sin 2\alpha}{4\pi} \right] \tag{15.50}$$

Example 15.1a: Single-phase ac regulator - #1

If the load of the 50 Hz 240V ac voltage regulator shown in figure 15.1 is $Z = 7.1 + j7.1 \Omega$, calculate the load natural power factor angle, ϕ . Then, assuming bipolar load current conduction, calculate

- (a) the rms output voltage, thence
- (b) the output power and rms current, whence input power factor and supply current distortion factor, μ

for

- i. $\alpha = \frac{1}{6}\pi$
- ii. $\alpha = \frac{1}{3}\pi$

Solution

From equation (15.3) the load natural power factor angle is

$$\phi = \tan^{-1} \omega L / R = \tan^{-1} X_L / R = \tan^{-1} 7.1 / 7.1 = \frac{1}{4}\pi \text{ (rad)} = 45^\circ$$

$$Z = \sqrt{R^2 + \omega^2 L^2} = \sqrt{7.1^2 + 7.1^2} = 10\Omega$$

i. $\alpha = \frac{1}{6}\pi$

(a) Since $\alpha = \pi / 6 < \phi = \frac{1}{4}\pi$, the load current is continuous and bidirectional, ac. The rms load voltage is 240V.

(b) From equation (15.20) the power delivered to the load is

$$P_o = I_{rms}^2 R = \frac{V^2}{Z} \cos \phi = \frac{240^2}{10\Omega} \cos \frac{1}{4}\pi = 4.07\text{kW}$$

The rms output current and supply current are both given by

$$I_{rms} = \sqrt{P_o / R} = \sqrt{4.07\text{kW} / 7.1\Omega} = 23.8\text{A}$$

The input power factor is the load natural power factor, that is

$$pf = \frac{P_o}{S} = \frac{4.07\text{kW}}{240\text{V} \times 23.8\text{A}} = 0.70 = \mu \cos \phi = \mu / \sqrt{2}$$

Thus the current input distortion factor is $\mu = 1$, for this sinusoidal current case.

ii. $\alpha = \frac{1}{3}\pi$

(a) Since $\alpha = \frac{1}{3}\pi > \phi = \frac{1}{4}\pi$, the load hence supply current is discontinuous. For $\alpha = \frac{1}{3}\pi > \phi = \frac{1}{4}\pi$ the extinction angle $\beta = 3.91$ rad or 224.15° can be extracted from figure 14.5a or determined after iteration using equation (15.4). The rms load voltage is given by equation (15.5).

$$\begin{aligned}
 V_{rms} &= V \left[\frac{1}{\pi} \left\{ (\beta - \alpha) - \frac{1}{2} (\sin 2\beta - \sin 2\alpha) \right\} \right]^{1/2} \\
 &= 240 \times \left[\frac{1}{\pi} \left\{ (3.91 - \frac{1}{2}\pi) - \frac{1}{2} (\sin 2 \times 3.91 - \sin \frac{1}{2}\pi) \right\} \right]^{1/2} \\
 &= 240 \times \sqrt{\frac{2.71}{\pi}} = 226.4V
 \end{aligned}$$

(b) The rms output (and input) current is given by equation (15.6), that is

$$\begin{aligned}
 I_{Oms} &= \frac{V}{Z} \left[\frac{1}{\pi} \left(\beta - \alpha - \frac{\sin(\beta - \alpha)}{\cos \phi} \cos(\beta + \alpha + \phi) \right) \right]^{1/2} \\
 &= \frac{240}{10} \left[\frac{1}{\pi} \left(3.91 - \frac{1}{2}\pi - \frac{\sin(3.91 - \frac{1}{2}\pi)}{\cos \frac{1}{4}\pi} \cos(3.91 + \frac{1}{2}\pi + \frac{1}{4}\pi) \right) \right]^{1/2} = 18.0A
 \end{aligned}$$

The output power is given by

$$\begin{aligned}
 P_o &= I_{rms}^2 R \\
 &= 18.0^2 \times 7.1\Omega = 2292W
 \end{aligned}$$

The load and supply power factors are

$$pf_o = \frac{P_o}{S} = \frac{2292W}{226.4V \times 18.0A} = 0.562 \quad pf = \frac{P_o}{S} = \frac{2292W}{240V \times 18.0A} = 0.531$$

The Fourier coefficients of the fundamental, a_1 and b_1 , are given by equation (15.14)

$$\begin{aligned}
 a_1 &= \frac{\sqrt{2}V}{2\pi} (\cos 2\alpha - \cos 2\beta) = \frac{\sqrt{2} \cdot 240V}{2\pi} (\cos \frac{3}{2}\pi - \cos 2 \times 3.91) = -28.8V \\
 b_1 &= \frac{\sqrt{2}V}{2\pi} (2(\beta - \alpha) - \sin 2\beta + \sin 2\alpha) = \frac{\sqrt{2} \cdot 240V}{2\pi} (2 \times (3.91 - \frac{1}{2}\pi) - \sin 2 \times 3.91 - \sin 2 \times \frac{1}{2}\pi) = 302.1V
 \end{aligned}$$

The fundamental power factor is

$$\cos \phi_1 = \cos \left(\tan^{-1} \left(\frac{a_1}{b_1} \right) \right) = \cos \left(\tan^{-1} \left(\frac{-28.8V}{302.1V} \right) \right) = 0.995$$

The current distortion factor is derived from

$$\begin{aligned}
 pf &= \mu \times \cos \phi_1 \\
 0.531 &= \mu \times 0.995
 \end{aligned}$$

That is, the current distortion factor is $\mu = 0.533$.

Example 15.1b: Single-phase ac regulator – #2

If the load of the 50 Hz 240V ac voltage regulator shown in figure 15.1 is $Z = 7.1 + j7.1 \Omega$, calculate the minimum controllable delay angle. Using this angle calculate

- maximum rms output voltage and current, and hence
- maximum output power and power factor
- thyristor I - V and di/dt ratings

Solution

As in example 15.1a, from equation (15.3) the load natural power factor angle is

$$\phi = \tan^{-1} \omega L / R = \tan^{-1} 7.1 / 7.1 = \frac{1}{4}\pi$$

The load impedance is $Z = 10\Omega$. The controllable delay angle range is $\frac{1}{4}\pi \leq \alpha \leq \pi$.

- The maximum controllable output occurs when $\alpha = \frac{1}{4}\pi$. From equation (15.2) when $\alpha = \phi$ the output voltage is the supply voltage, V , and

$$i(\omega t) = \frac{\sqrt{2}V}{Z} \sin(\omega t - \frac{1}{4}\pi) \quad (A)$$

The load hence supply rms maximum current, is therefore

$$I_{rms} = 240V / 10\Omega = 24A$$

$$ii. \text{ Power} = I_{rms}^2 R = 24^2 \times 7.1\Omega = 4090W$$

$$\begin{aligned}
 \text{power factor} &= \frac{\text{power output}}{\text{apparent power output}} \\
 &= \frac{I_{rms}^2 R}{VI_{rms}} = \frac{24^2 \times 7.1\Omega}{240V \times 10A} = 0.71 \quad (= \cos \phi) \quad \mu = 1
 \end{aligned}$$

- Each thyristor conducts for π radians, between α and $\pi + \alpha$ for T1 and between $\pi + \alpha$ and $2\pi + \alpha$ for T2. The thyristor average current is

$$\begin{aligned}
 \bar{I}_T &= \frac{1}{2\pi} \int_{\alpha=\phi}^{\alpha+\pi=\phi+\pi} \sqrt{2}V \sin(\omega t - \phi) d\omega t \\
 &= \frac{\sqrt{2}V}{\pi Z} = \frac{\sqrt{2} \times 240V}{\pi \times 10\Omega} = 10.8A
 \end{aligned}$$

The thyristor rms current rating is

$$\begin{aligned}
 I_{Tms} &= \left[\frac{1}{2\pi} \int_{\alpha=\phi}^{\alpha+\pi=\phi+\pi} \left\{ \sqrt{2}V \sin(\omega t - \phi) \right\}^2 d\omega t \right]^{1/2} \\
 &= \frac{\sqrt{2}V}{2Z} = \frac{\sqrt{2} \times 240V}{2 \times 10\Omega} = 17.0A = I_{rms} / \sqrt{2}
 \end{aligned}$$

Maximum thyristor di/dt is derived from

$$\begin{aligned}
 d i(\omega t) / dt &= d/dt \frac{\sqrt{2}V}{Z} \sin(\omega t - \frac{1}{4}\pi) \\
 &= \frac{\sqrt{2}V}{Z} \omega \cos(\omega t - \frac{1}{4}\pi) \quad (A/s)
 \end{aligned}$$

This has a maximum value when $\omega t - \frac{1}{4}\pi = 0$, that is at $\omega t = \alpha = \phi$, then

$$\begin{aligned}
 d\hat{i}(\omega t) / dt &= \frac{\sqrt{2}V\omega}{Z} \\
 &= \frac{\sqrt{2} \times 240V \times 2\pi \times 50\text{Hz}}{10\Omega} = 10.7A/ms
 \end{aligned}$$

Thyristor forward and reverse blocking voltage requirements are $\sqrt{2}V = \sqrt{2} \times 240 = 340V$ dc.

Example 15.1c: Single-phase ac regulator – pure inductive load

If the load of the 50 Hz 240V ac voltage regulator shown in figure 15.1 is $Z = jX = j10 \Omega$, and the delay angle α is first $\frac{3}{4}\pi$ then second $\frac{1}{4}\pi$ calculate

- maximum rms output voltage and current, and hence
- thyristor I - V ratings

Assume the thyristor gate pulses are of a short duration relative to the 10ms half period.

Solution

For a purely inductive load, the current extinction angle is always $\beta = 2\pi - \alpha$, that is, symmetrical about π and $\tan \phi \rightarrow \infty$.

- If the delay angle $\pi > \alpha > \frac{1}{2}\pi$ and symmetrical, then the load current is discontinuous alternating polarity current pulses as shown in figure 15.3a.
- If the delay angle $0 < \alpha < \frac{1}{2}\pi$, and a short duration gate pulse is used for each thyristor, then the output comprises discontinuous unidirectional current pulses of duration $2\pi - 2\alpha$, as shown in figure 15.3c.

- $\alpha = \frac{3}{4}\pi$: symmetrical gate pulses - discontinuous alternating current pulses.

The average output voltage and current are zero, $\bar{I}_o = \bar{V}_o = 0$. The maximum rms load voltage and current, with bidirectional output current and voltage, are when $\alpha = \frac{1}{2}\pi$

$$\begin{aligned}
 \hat{V}_{rms} &= V = 240V \\
 \hat{I}_{rms} &= \frac{V}{X} = \frac{240V}{10\Omega} = 24A
 \end{aligned}$$

- i. The rms output current and voltage are given by equations (15.45) and (15.46), respectively, with $\Phi = \pi$ and $\beta = 2\pi - \alpha$, that is

$$I_{rms} = \frac{V}{X} \left[\frac{2}{\pi} \left((\pi - \alpha)(2 + \cos 2\alpha) + \frac{3}{2} \sin 2\alpha \right) \right]^{1/2}$$

$$= \frac{240V}{10\Omega} \left[\frac{2}{\pi} \left((\pi - 3/4\pi) \left(2 + \cos \frac{3}{2}\pi \right) + \frac{3}{2} \sin \frac{3}{2}\pi \right) \right]^{1/2} = 5.1A$$

$$V_{rms} = V \left[\frac{2}{\pi} \left\{ (\pi - \alpha) + \frac{1}{2} \sin 2\alpha \right\} \right]^{1/2}$$

$$= 240V \left[\frac{2}{\pi} \left\{ (\pi - 3/4\pi) + \frac{1}{2} \sin \frac{3}{2}\pi \right\} \right]^{1/2} = 54.65V$$

- ii. Each thyristor conducts half the load current hence $I_T = 5.1A/\sqrt{2} = 3.6A$ rms. Before start-up, at shut-down or during operation, each thyristor has to block bi-directionally $\sqrt{2} \times 240 = 340V$, peak. The average thyristor current is

$$\bar{I}_T = \frac{\sqrt{2} V}{\pi \omega L} [(\pi - \alpha) \cos \alpha + \sin \alpha]$$

$$= \frac{\sqrt{2} \times 240V}{\pi \times 10\Omega} [(\pi - 3/4\pi) \cos 3/4\pi + \sin 3/4\pi] = 1.64A$$

- b. $\alpha = 1/4 \pi$: short gate pulses – discontinuous unidirectional current pulses. The average output voltage and current are not zero, $\bar{I}_o \neq 0$ and $\bar{V}_o \neq 0$.

- i. The rms output current and voltage are given by equations (15.45) and (15.46), respectively, with $\Phi = \pi$ and $\beta = 2\pi - \alpha$, that is

$$I_{rms} = \frac{V}{X} \left[\frac{1}{\pi} \left((\pi - \alpha)(2 + \cos 2\alpha) + \frac{3}{2} \sin 2\alpha \right) \right]^{1/2}$$

$$= \frac{240V}{10\Omega} \left[\frac{1}{\pi} \left((\pi - 1/4\pi) \left(2 + \cos 1/2\pi \right) + \frac{3}{2} \sin 1/2\pi \right) \right]^{1/2} = 37.75A$$

$$V_{rms} = V \left[\frac{1}{\pi} \left\{ (\pi - \alpha) + \frac{1}{2} \sin 2\alpha \right\} \right]^{1/2}$$

$$= 240V \left[\frac{1}{\pi} \left\{ (\pi - 1/4\pi) + \frac{1}{2} \sin 1/2\pi \right\} \right]^{1/2} = 228.8V$$

- ii. Although only one thyristor conducts, which one that actually conducts may be random, thus both thyristor are rms rated for $I_T = 37.75A$. Whilst operational, the maximum thyristor voltage is $\sqrt{2} \times 240 \sin 1/4\pi$, that is 240V. But before start-up or at shut-down, each thyristor has to block bi-directionally, $\sqrt{2} \times 240 = 340V$, peak. The average thyristor (and supply and load) current is

$$\bar{I}_T = \frac{\sqrt{2} V}{\pi \omega L} [(\pi - \alpha) \cos \alpha + \sin \alpha]$$

$$= \frac{\sqrt{2} \times 240V}{\pi \times 10\Omega} [(\pi - 1/4\pi) \cos 1/4\pi + \sin 1/4\pi] = 25.6A$$

♣

Example 15.1d: Single-phase ac regulator – #1 with ac back emf composite load

A 230V 50Hz mains ac thyristor chopper has a load composed of a 10Ω resistor in series with a 138V 50Hz ac voltage source that leads the mains by 30°. If the thyristor triggering angle is 90° with respect to the ac mains, determine

- the rms load current and maximum rms load current for any phase delay angle
- the power dissipated in the passive part of the load
- the thyristor average and rms current ratings and voltage ratings
- power dissipated in the thyristors when modelled by $v_T = v_o + r_o \times i_T = 1.2 + 0.01 \times i_T$

Repeat the calculations if the passive part of the load is a 20mH inductor and the ac back emf lags the 50Hz ac mains by 30°.

Solution

ac back emf with a pure resistive load

From equation (15.48), the voltage across the resistive part of the load is

$$V_R = \sqrt{V^2 + V_{bac}^2 - 2V V_{bac} \cos \psi}$$

$$= \sqrt{230^2 + 138^2 - 2 \times 230 \times 138 \times \cos 30} = 130.3V$$

with an angle of $\varphi = -32.8^\circ$ with respect to the ac mains, given by $\psi = 30^\circ$ and $V_{bac}/V = 138V/230V = 0.6$ in the fourth quadrant of figure 15.5. From the phasor diagram in figure 15.5, the thyristor firing angle with respect to the load resistor voltage is $\alpha_R = \alpha - \varphi = 90^\circ - 32.8^\circ = 57.8^\circ$.

- i. The load rms current is given by equation (15.24), that is

$$I_{rms} = \frac{V_R}{R} \sqrt{1 - \frac{2\alpha_R - \sin 2\alpha_R}{2\pi}}$$

$$= \frac{130.3V}{10\Omega} \sqrt{1 - \frac{57.8^\circ - \sin 2 \times 57.8^\circ}{180^\circ + 2\pi}} = 13.03A \times 0.732 = 9.54A$$

The maximum rms load current is 13A when is $\alpha_R = 0$, that is when $\alpha = -\varphi = 32.8^\circ$.

- ii. The 10Ω resistor losses are

$$P_{10\Omega} = I_{rms}^2 \times 10\Omega$$

$$= 9.54^2 \times 10\Omega = 910.1W$$

- iii. The thyristor current ratings are

$$I_{T rms} = I_{rms} / \sqrt{2}$$

$$= 16.83 / \sqrt{2} = 11.9A$$

From equation (15.22), the average thyristor current is

$$\bar{I}_T = \frac{1}{2} \frac{\sqrt{2} V_R}{\pi R} (1 + \cos \alpha_R)$$

$$= \frac{1}{2} \frac{\sqrt{2} \times 130.3V}{\pi \times 10\Omega} (1 + \cos 57.8^\circ) = 4.5A$$

The thyristors effectively experience a forward and reverse voltage associated with a single ac source of 130.3V ac. Without phase control the maximum thyristor voltage is $\sqrt{2} \times 130.3V = 184.3V$. If the triggering angle α is less than $90^\circ - \varphi = 122.8^\circ$ (with respect to the ac mains) then the maximum off-state voltage is less, namely

$$\hat{V}_T = \sqrt{2} \times 130.3 \times \sin(\alpha - 32.8^\circ) \text{ if } \alpha < 122.3^\circ$$

- iv. The power dissipated in each thyristor is

$$P_T = v_o \bar{I}_T + r_o I_{T rms}^2$$

$$= 1.2V \times 4.5A + 0.01\Omega \times 11.9^2 = 6.8W$$

ac back emf with a pure reactive load

The voltage across the inductive part of the load is the same as for the resistive case, namely 130.3V. In this case the ac back emf lags the ac mains. The phase angle with respect to the ac mains is $\varphi = 32.8^\circ$, given by $\psi = -30^\circ$ and $V_{bac}/V = 138V/230V = 0.6$ in the second quadrant of figure 15.5. Being a purely inductive load across the 130.3V ac voltage, the current lags this voltage by 90°. From the phasor diagram in figure 15.5, the thyristor firing angle with respect to the load inductor voltage is $\alpha_L = \alpha + \varphi = 90^\circ + 32.8^\circ = 122.8^\circ$. Since the effective delay angle α_L is greater than 90°, symmetrical, bipolar, discontinuous load current flows, as considered in section 15.1ii.

- i. With a 20mH load inductor, the load rms current is given by equation (15.45), that is

$$I_{rms} = \frac{V_L}{X} \left[\frac{2}{\pi} \left((\pi - \alpha_L)(2 + \cos 2\alpha_L) + \frac{3}{2} \sin 2\alpha_L \right) \right]^{1/2}$$

$$= \frac{130.3V}{2\pi \times 50\text{Hz} \times 0.02\text{H}} \sqrt{\left(2 - \frac{122.8^\circ}{90^\circ} \right) \left(2 + \cos 2 \times 122.8^\circ \right) + \frac{3}{2} \sin 2 \times 122.8^\circ}$$

$$= 20.74A \times 0.373 = 7.73A$$

The maximum bipolar rms load current is when $\alpha_R = 90^\circ$, $I_{rms} = 20.74$, and $\alpha = 90^\circ - \varphi = 32.8^\circ$.

- ii. The 20mH inductor losses are zero.
 iii. The thyristor current ratings are

$$I_{T\text{ rms}} = I_{\text{ rms}} / \sqrt{2} \\ = 7.73 / \sqrt{2} = 5.47\text{A}$$

From equation (15.43), the average thyristor current is

$$\bar{I}_T = \frac{\sqrt{2} V_L}{\pi \omega L} [(\pi - \alpha_L) \cos \alpha_L + \sin \alpha_L] \\ = 20.74\text{A} \frac{\sqrt{2} V_L}{\pi} \left[\pi \left(1 - \frac{122.8^\circ}{180^\circ} \right) \times \cos 122.8^\circ + \sin 122.8^\circ \right] = 2.80\text{A}$$

The thyristors effectively experience a forward and reverse voltage associated with a single ac source of 130.3V ac. Without phase control the maximum thyristor voltage is $\sqrt{2} \times 130.3\text{V} = 184.3\text{V}$. Since $\alpha_R \geq 90^\circ$ is necessary for continuous bipolar load current, 184.3V will always be experienced by the thyristors for any $\alpha_R > 90^\circ$.

- iv. The power dissipated in each thyristor is

$$P_T = V_o \bar{I}_T + r_o I_{T\text{ rms}}^2 \\ = 1.2\text{V} \times 2.8\text{A} + 0.01\Omega \times 5.47^2 = 3.66\text{W}$$

15.1.2 Single-phase ac regulator – integral cycle control - line commutated

In thyristor heating applications, load harmonics are unimportant and integral cycle control, or burst firing, can be employed. Figure 15.6a shows the regulator when a triac is employed and figure 15.6b shows the output voltage indicating the regulator's operating principle. Because of the low frequency sub-harmonic nature of the output voltage, this type of control is not suitable for incandescent lighting loads since flickering would occur and with ac motors, undesirable torque pulsations would result.

In many heating applications the load thermal time constant is long (relative to 20ms, that is 50Hz) and an acceptable control method involves a number of mains cycles on and then off. Because turn-on occurs at zero voltage cross-over and turn-off occurs at zero current, which is near a zero voltage cross-over, supply harmonics and radio frequency interference are low. The lowest order harmonic in the load is $1/T_p$.

For a resistive load, the output voltage (and current) is defined by

$$v_o = i_o R = \sqrt{2} V \sin(\omega t) \quad \text{for } 0 \leq \omega t \leq 2\pi m \\ = 0 \quad \text{for } 2\pi m \leq \omega t \leq 2\pi N \quad (15.51)$$

where $T_p = 2\pi N/\omega$.

The rms output voltage (and current) is

$$V_{\text{ rms}} = \left(\frac{1}{2\pi} \int_0^{2\pi m/N} (\sqrt{2} V \sin \omega t)^2 d\omega t \right)^{1/2} \\ V_{\text{ rms}} = I_{\text{ rms}} R = V \sqrt{m/N} = V \sqrt{\delta} \quad \text{where the duty cycle } \delta = m/N \quad (15.52)$$

The Fourier coefficient and phase angle for each load voltage harmonic (for $n \neq N$) are given by

$$c_n = \sqrt{2} V \frac{2N}{\pi(N^2 - n^2)} \sin \pi n \delta \\ \phi_n = \pi(1 - n\delta) \quad \text{for } n < N \\ \phi_n = \pi(n\delta - 1) \quad \text{for } n > N \quad (15.53)$$

When $n > N$ the harmonics are above $1/T_p$, while if $n < N$ subharmonics of $1/T_p$ are produced. For the case when $n = N$, the coefficient and phase angle for the $\sin \pi m$ term ($a_{n=N} = 0$) are

$$b_{n=N} = c_{n=N} = \sqrt{2} V \frac{m}{N} = \sqrt{2} V \delta \quad \text{and } \phi_{n=N} = 0 \quad (15.54)$$

Note the displacement angle between the ac supply voltage and the load voltage frequency component at the supply frequency, $n = N$, is $\phi_{n=N} = 0$. Therefore the fundamental power factor angle $\cos \phi_{n=N} = \cos 0 = 1$.

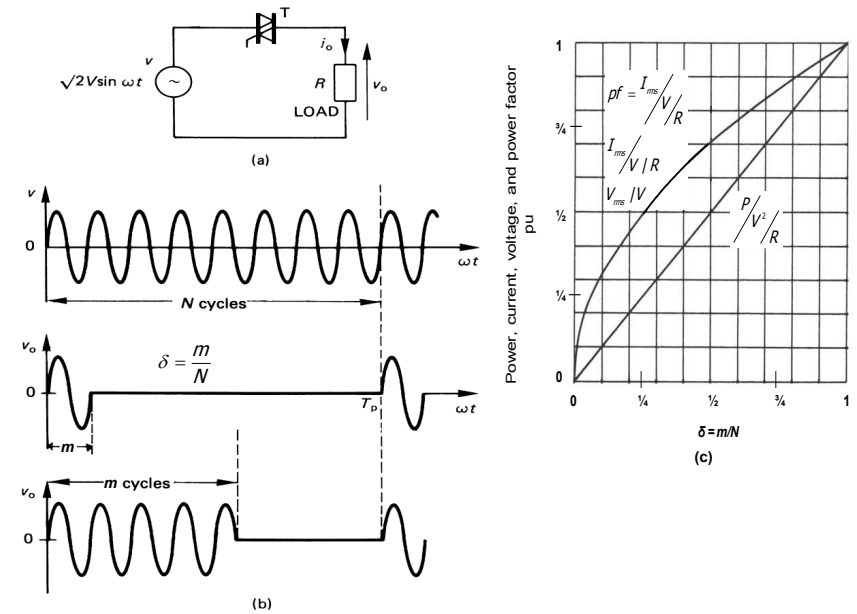

Figure 15.6. Integral half-cycle single-phase ac control: (a) circuit connection using a triac; (b) output voltage waveforms for one-eighth maximum load power and nine-sixteenths maximum power; and (c) normalised supply power factor and power output.

The output power is

$$P = \frac{m}{N} \frac{V^2}{R} = \delta \times \frac{V^2}{R} = I_{\text{ rms}}^2 R \quad (\text{W}) \quad (15.55)$$

where n is the number of on cycles and N is the number of cycles in the period T_p .

The average and rms thyristors currents are, respectively

$$\bar{I}_T = \frac{\sqrt{2} V}{\pi R} \frac{m}{N} = \frac{\sqrt{2} V}{\pi R} \delta \quad I_{T\text{ rms}} = \frac{\sqrt{2} V}{2R} \sqrt{\frac{m}{N}} = \frac{\sqrt{2} V}{2R} \sqrt{\delta} \quad (15.56)$$

From equation (15.54), the supply displacement factor $\cos \psi_{n=N}$ is unity and supply power factor λ is $\sqrt{m/N} = \sqrt{P/P} = \sqrt{\delta}$. From $p_f = \lambda = \mu \cos \phi_{n=N} = \mu$, the distortion factor μ is $\sqrt{m/N} = \sqrt{\delta}$. The rms voltage at the supply frequency is $V_m/N = \delta V$ and the power transfer ratio is $m/N = \delta$. For a given percentage of maximum output power, the supply power factor is the same for integral cycle control and phase angle control. The introduction of sub-harmonics tends to restrict this control technique to resistive heating type application. Temperature effects on load resistance R have been neglected, as have semiconductor on-state voltages. Finer resolution output voltage control is achievable if integral half-cycles are used rather than full cycles. The equations remain valid, but the start of multiples of half cycles are alternately displaced by π so as to avoid a dc component in the supply and load currents. Multiple cycles need not be consecutive within each period.

Example 15.2: Integral cycle control

The power delivered to a 12 Ω resistive heating element is derived from an ideal sinusoidal supply $\sqrt{2} 240 \sin 2\pi 50 \times t$ and is controlled by a series connected triac as shown in figure 15.6. The triac is controlled from its gate so as to deliver integral ac cycle pulses of three (m) consecutive ac cycles from four (N).

Calculate

- i. the percentage power transferred compared to continuous ac operation
- ii. the supply power factor, distortion factor, and displacement factor
- iii. the supply frequency (50Hz) harmonic component voltage of the load voltage
- iv. the triac maximum di/dt and dv/dt stresses
- v. the phase angle α , to give the same load power when using phase angle control. Compare the maximum di/dt and dv/dt stresses with part iv.
- vi. the output power steps when m , the number of conducted cycles is varied with respect to $N = 4$ cycles. Calculate the necessary phase control α equivalent for the same power output. Include the average and rms thyristor currents.
- vii. what is the smallest power increment if half cycle control were to be used?
- viii. tabulate the harmonics and rms subharmonic component per unit magnitudes of the load voltage for $m = 0, 1, 2, 3, 4$; and for harmonics $n = 0$ to 12. (suggestion: use Excel)

Solution

The key data is: $m = 3$ $N = 4$ ($\delta = 3/4$) $V = 240V$ rms ac, 50Hz

- i. The power transfer, given by equation (15.55), is

$$P = \frac{V^2 m}{R N} = \frac{V^2}{R} \delta = \frac{240^2}{12\Omega} \times 3/4 = 4800 \times 3/4 = 3.6\text{kW}$$

That is 75% of the maximum power is transferred to the load as heating losses.

- ii. The displacement factor, $\cos\psi$, is 1. The distortion factor is given by

$$\mu = \sqrt{\frac{m}{N}} = \sqrt{\delta} = \sqrt{3/4} = 0.866$$

Thus the supply power factor, λ , is

$$\lambda = \mu \cos\psi = \sqrt{\frac{m}{N}} = \sqrt{\delta} = 0.866 \times 1 = 0.866$$

- iii. The 50Hz rms component of the load voltage is given by

$$V_{50\text{Hz}} = V \frac{m}{N} = V \delta = 240 \times 3/4 = 180V \text{ rms}$$

- iv. The maximum di/dt and dv/dt occur at zero cross over, when $t = 0$.

$$\begin{aligned} \left. \frac{dV_s}{dt} \right|_{\max} &= \frac{d}{dt} \sqrt{2} 240 \sin 2\pi 50t \Big|_{t=0} \\ &= \sqrt{2} 240 (2\pi 50) \cos 2\pi 50t \Big|_{t=0} \\ &= \sqrt{2} 240 (2\pi 50) = 0.107 \text{ V}/\mu\text{s} \end{aligned}$$

$$\begin{aligned} \left. \frac{dV_s}{dt R} \right|_{\max} &= \frac{d}{dt} \frac{\sqrt{2} 240}{12\Omega} \sin 2\pi 50t \Big|_{t=0} \\ &= \sqrt{2} 20 (2\pi 50) \cos 2\pi 50t \Big|_{t=0} \\ &= \sqrt{2} 20 (2\pi 50) = 8.89 \text{ A/ms} \end{aligned}$$

- v. To develop the same load power, 3600W, with phase angle control, with a purely resistive load, implies that both methods must develop the same rms current and voltage, that is, $V_{rms} = \sqrt{R P} = V \sqrt{m/N} = V \sqrt{\delta}$. From equation (15.5), when the extinction angle, $\beta = \pi$, since the load is resistive

$$V_{rms} = \sqrt{R \times P} = V \sqrt{m/N} = V \sqrt{\delta} = V \left[\frac{1}{\pi} \{ (\pi - \alpha) + \frac{1}{2} \sin 2\alpha \} \right]^{1/2}$$

that is

$$\delta = \frac{m}{N} = \frac{1}{\pi} \{ (\pi - \alpha) + \frac{1}{2} \sin 2\alpha \} = 3/4 = \frac{1}{\pi} \{ (\pi - \alpha) + \frac{1}{2} \sin 2\alpha \}$$

Solving $0 = 1/4\pi - \alpha + 1/2 \sin 2\alpha$ iteratively gives $\alpha = 63.9^\circ$.

When the triac turns on at $\alpha = 63.9^\circ$, the voltage across it drops virtually instantaneously from $\sqrt{2} 240 \sin 63.9 = 305V$ to zero. Since this is at triac turn-on, this high dv/dt does not represent a turn-on dv/dt stress. The maximum triac dv/dt stress tending to turn it on is at zero voltage cross over, which is 107 V/ms, as with integral cycle control. Maximum di/dt occurs at triac turn on where the current rises from zero amperes to $305V/12\Omega = 25.4A$ quickly. If the triac turns on in approximately 1 μ s, then this would represent a di/dt of 25.4A/ μ s. The triac initial di/dt rating would have to be in excess of 25.4A/ μ s.

cycles	period	duty	power	\bar{I}_{Th}	I_{Thrms}	Delay angle	Displacement factor	Distortion factor	Power factor
m	N	δ	W	A	A	α	$\cos\psi$	μ	λ
0	4	0	0	0	0	180°			
1	4	1/4	1200	2.25	7.07	114°	1	1/2	1/2
2	4	1/2	2400	4.50	10.0	90°	1	0.707	0.707
3	4	3/4	3600	6.75	12.2	63.9°	1	0.866	0.866
4	4	1	4800	9	14.1	0	1	1	1

- vi. The output power can be varied using $m = 0, 1, 2, 3$, or 4 cycles of the mains. The output power in each case is calculated as in part 1 and the equivalent phase control angle, α , is calculated as in part v. The appropriate results are summarised in the table.

- vii. Finer power step resolution can be attained if half cycle power pulses are used as in figure 15.6b. If one complete ac cycle corresponds to 1200W then by using half cycles, 600W power steps are possible. This results in nine different power levels if $N = 4$, from 0W to 4800W, in 600W steps.

- vii. The following table shows harmonic components, rms subharmonics, etc., for $N = 4$, (up to the twelfth) which are calculated as follows.

For $n \neq 4$, (that is not 50Hz) the harmonic magnitude is calculated from equation (15.53).

$$c_n = \frac{2\sqrt{2} V N}{\pi(N^2 - n^2)} \sin\left(\frac{\pi n m}{N}\right) = \frac{8\sqrt{2} V}{\pi(16 - n^2)} \times \sin\left(\frac{\pi n m}{4}\right) \quad \text{when } N = 4 \text{ and } n \neq 4$$

Equation (15.54) gives the 50Hz load component ($n = 4$).

$$c_{n=N=4} = \sqrt{2} V \frac{m}{N} = \sqrt{2} V \frac{m}{4} \quad \text{when } N = 4 \text{ and } n = 4$$

Component magnitudes (but not necessarily phase) are equal about $\delta = 1/2$ when N is even.

The rms output voltage is given by equation (15.52) or the square root of the sum of the squares of the harmonics, that is

$$V_{rms} = V \sqrt{m/N} = V \sqrt{\sum_{n=1}^{\infty} c_n^2}$$

The ac subharmonic component (that is components less than 50Hz) is given by

$$V_{ac,sub} = \sqrt{2} V \left[c_1^2 + c_2^2 + c_3^2 \right]^{1/2}$$

From equations (15.52) and (15.54), the non fundamental ($\neq 50\text{Hz}$ ac) component is given by

$$V_{ac} = \sqrt{V_{rms}^2 - V_{50\text{Hz}}^2} = V \sqrt{\frac{m}{N} - \left(\frac{m}{N}\right)^2} = V \sqrt{\delta(1-\delta)}$$

Normalised components		δ and m					m/N
		0	$\frac{1}{4}$	$\frac{1}{2}$	$\frac{3}{4}$	1	
n	Hz	0	1	2	3	4	
0	0	0	0	0	0	0	m/N fundamental
1	12.5	0	0.120	0.170	0.120	0	
2	25	0	0.212	0	-0.212	0	
3	37.5	0	0.257	-0.364	0.257	0	
4	50	0	$\frac{1}{4}$	$\frac{1}{2}$	$\frac{3}{4}$	1	
5	62.5	0	0.200	-0.283	0.200	0	
6	75	0	0.127	0	-0.127	0	
7	87.5	0	0.055	0.077	0.055	0	
8	100	0	0	0	0	0	
9	112.5	0	-0.028	-0.039	-0.028	0	
10	125	0	-0.030	0	0.030	0	
11	137.5	0	-0.017	0.024	-0.017	0	
12	150	0	0	0	0	0	
all n	sum square	0	0.249	0.499	0.749	1	$\sum_1^{12} c_n^2$
all n	rms	0	0.499	0.707	0.866	1	$\sqrt{\sum_1^{12} c_n^2}$
all n check	exact rms	0	0.5	0.707	0.866	1	$\sqrt{\frac{m}{4}} = \sqrt{\delta}$
all n but not $n = 4$	ac harmonic rms	0	0.432	0.499	0.432	0	$\sqrt{\sum_1^{12} c_n^2 - c_4^2}$
$n \leq 3$	sub harmonics rms	0	0.354	0.401	0.354	0	$\sqrt{\sum_1^3 c_n^2}$
$n \geq 5$	upper harmonics rms	0	0.247	0.297	0.247	0	$\sqrt{\sum_5^{12} c_n^2}$
$n \geq 5$ check	upper harmonics rms	0	0.249	0.298	0.249	0	$\sqrt{\frac{m}{4} - \sum_1^3 c_n^2 - \left(\frac{m}{4}\right)^2}$
$pf = \lambda$	power factor	0	$\frac{1}{2}$	0.707	0.866	1	$\sqrt{\frac{m}{4}} = \sqrt{\delta}$
	power pu	0	$\frac{1}{4}$	$\frac{1}{2}$	$\frac{3}{4}$	1	$\frac{1}{4}m$



15.1.3 The solid-state relay (SSR)

A *Solid-State Relay* (SSR) is a normally-open, electrical switch comprising solid-state semiconductors and/or electronic components that can be used in place of a mechanical relay to switch electricity to a load. An SSR offers enhanced electrical performance and reliability over electro-mechanical relay alternatives.

An SSR is a totally electronic device that depends on the electrical, magnetic, and optical properties of semiconductors to control the flow of current in a circuit. It is normally comprised of a low current control side (equivalent to the coil on a mechanical relay) and a high-current load side (equivalent to the contacts of a conventional mechanical relay). SSRs typically feature electrical isolation up to several kilovolts between the control and load sides. Because of this isolation, the load side electronics of the relay is powered from the switched line, such that both the line voltage and a load (additionally to a control signal) must be present for the relay to operate.

An SSR contains one or more LEDs in the input (drive) section and provides optical coupling to a phototransistor or photodiode array, which in turn connects to driver circuitry that functions as an interface to the switching device or devices at the output. The power switching device is typically a MOSFET or TRIAC (usually two anti-parallel connected silicon controlled rectifiers, SCRs).

The advantages of solid-state relays versus their electro-mechanical counterparts are numerous:

- Higher reliability, reliable operation in harsh environments, longer life
- Elimination of switch bounce since no moving parts, giving a longer lifetime than electro-mechanical devices
- Smaller size
- Faster switching times, typically 100 μ s
- Elimination of hv arcing and pitting with reduced electromagnetic interference
- Lower triggering currents, that is, low power consumption, compared to electromechanical devices. But contact losses are lower than thyristor on-state losses
- Robust packaging, resistant to shock and vibration, not dependent upon orientation
- No moving parts, thus silent operation

In order to utilize the benefits and flexibility of power MOSFET/IGBT technology, it may be required that sophisticated driver circuitry be used to drive these devices. MOSFET/IGBT based SSRs are more versatile than their TRIAC based counterparts. TRIAC based devices are limited only to ac load applications, whilst MOSFET/IGBT based devices can cater for ac and dc loads. Triac output SSRs are general-purpose relays typically used only for resistive type loads. SCR output solid-state relays are used to switch resistive or inductive loads, especially loads with high inrush currents. Thyristor technology is slower switching than MOSFET/IGBT SSR technology, but can handle higher voltage and current levels.

Thyristor technology based SSRs are specifically considered in this section, although many of the aspects considered are applicable to MOSFET/IGBT based SSR technology.

AC output solid-state relays are used to control the flow of electrical energy in alternating current power systems. The input control (equivalent to the electro-mechanical relay coil) voltages can be either ac or dc. The majority of solid-state relays require less power than electromechanical types to turn on and are readily interfaced. Another advantage of having no moving parts is that solid-state relays offer fast response time without contact bounce. For instantaneous turn-on types, the time between applying a command signal to the control circuit and the output circuit turning on is typically 20 μ s, although 100 μ s may be quoted as a maximum. Alternatively the electronic control circuitry can delay the turn-on of a solid-state relay until the next voltage zero of the ac supply. Thus ac output solid-state relays can have two types of turn-on response: instantaneous (also known as phase control or random turn-on) and zero crossing.

Zero voltage turn-on refers to a control circuit which after the presence of a control signal, only permits the relay's output to switch on load current if the ac line voltage is at or near a zero ac supply voltage point. *Random turn-on* refers to a control circuit that energizes the relay's output irrespective of the value of the ac line voltage at the time of the turn-on command. The opto-coupler design and selection determine the zero or random function.

All ac output solid-state relays, which use SCRs or triacs as the output switch, after the removal of the control signal, will turn off at the next ac current zero. The relay may conduct for an additional half cycle of the ac supply frequency if the control signal is removed within 100 μ s of the next current zero. Because of the response time of solid-state relays, power to a load can be applied accurately and removed precisely. This is important when applications involve the switching of highly capacitive loads, and is an advantage over electromechanical switching.

Zero-crossing relays are used with resistive loads while random turn-on relays are used with inductive loads, for example motors, transformers, coils, etc. Zero-crossing relays may also be used with inductive loads, but consideration must be given to the power factor of the load. If the load is too inductive, then the output of a zero-crossing relay may half-wave (half-wave rectification of the ac source), whence a random-fire SSR should be used in the application.

A random-fire SSR may also be used in resistive applications. Some applications require that the load only be energized for a portion of the ac cycle. This can be accomplished with a random SSR (due to its relatively fast turn-on time), given that an appropriate controller is used. However, the initial surge current will be higher due to the SSR switching power when the line voltage is closer to its peak.

The key basic element of a solid-state relay is the output switch, sometimes a triac but more often (and more reliably) parallel connected back-to-back SCRs. This output switch is the key part of a solid-state relay, being the component that handles the power.

Circuit description

The basic SSR comprises a number of stages, from the control signal input through to the power output stage and its voltage transient protection, as shown by the functional block diagram in figure 15.7.

Input Circuit Commonly referred to as the 'primary', the input of an SSR may consist of a resistor in series with the optical-isolator, or of a more complex circuit with current regulation, reverse polarity protection, EMC filtering, etc. In either case, both serve the same function, which is to sense the application of a control signal commanding SSR turn on.

Optical Isolation The optical isolator in an SSR provides isolation between the input circuitry / control system, and the output circuit connected to the ac mains. The type of optical isolator used may also determine whether it is a zero-crossing or random-fire output.

Trigger Circuit This circuitry processes the input signal and switches the output state of the SSR. The trigger circuit may be internal or external to the optical-isolator.

Switching Circuit This is the part of the SSR that switches the power to the load. It usually consists of an IGBT or MOSFET for dc application, and a triac or parallel connected back-to-back SCRs for ac application.

Protection Circuit Many applications require some form of electrical protection to prevent the SSR from being damaged in the application, or from misfiring due to external conditions. The protective devices (RC snubbers and transient voltage suppressors) may be incorporated into the design of an SSR, or mounted externally.

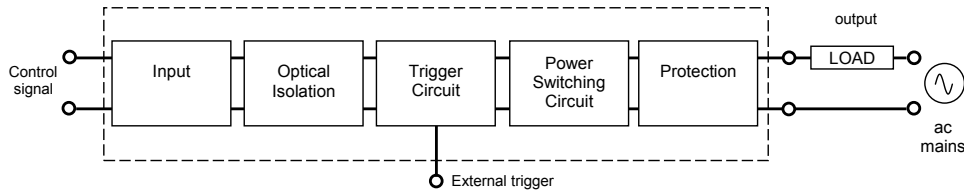

Figure 15.7. Block diagram of the functional stages of a solid-state relay.

15.1.3i Principle of operation

AC output solid-state relays are normally powered by the ac line, by connecting the two gates of the output SCRs through a controlled high voltage switch. In Figure 15.8a, when S1 is closed, the gates of SCR1 and SCR2 are connected, and current from the ac supply flows through either R1 or R2 into the gate of whichever SCR is forward biased; turning the SCR on and the relay conducts. While S1 is closed this action continues, reversing each half cycle of the ac supply and SCR1 and SCR2 conduct alternately. When S1 is opened, whichever SCR is conducting continues to conduct until reversed biased, when it turns off, and since the other SCR now has no gate current, the relay opens.

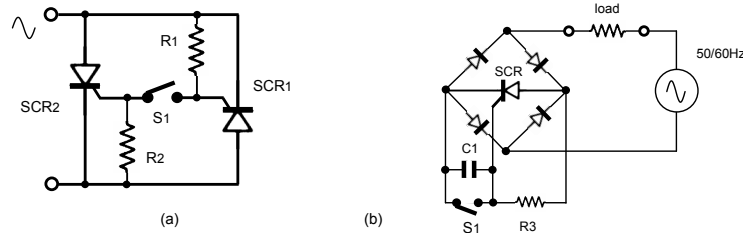

Figure 15.8. SSR: (a) back-to-back SCR ac, normally-off output stage and (b) normally-on full-wave diode bridge version.

Either of two circuits can provide the S1 switch function, with both offering optical isolation between the control and output of the solid-state relay. The circuit in Figure 15.9a uses an opto-triac as the isolating element, while the circuit in Figure 15.9b uses an opto-transistor as the isolating element. Each approach has specific features. Optically coupled SCRs are also used, with photovoltaic couplers used in MOSFET output dc relays.

The opto-transistor circuit in Figure 15.9b requires less control current to operate, conserving power, space, and money in installations that use many relays. Another advantage of the opto-transistor approach is the flexibility offered to modify and tailor the control circuit characteristics in terms of a zero crossing voltage window, noise suppression, etc. The disadvantage is that it is more expensive. The opto-triac circuit in figure 15.9a requires a higher control current for reliable operation, especially with inductive loads. Additionally, the control circuit characteristics are not accessible so it is inflexible. With fewer components, this type of circuit is usually less expensive. With a modified version of the opto-transistor circuit of Figure 15.9b, a normally closed solid-state relay can be realised.

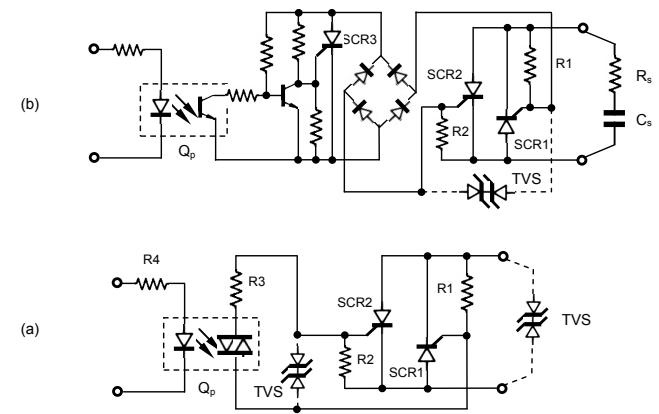

Figure 15.9. Opto-coupled output stage and optional over-voltage protection, interfaced using an: (a) opto-triac and (b) opto-transistor.

Solid-state relays can be either dc or ac voltage controlled, as shown in figure 15.10 parts a and b respectively. For ac input control, in figure 15.10b, the ac signal is rectified and filtered with capacitors to provide a dc signal to the opto-transistor or opto-triac LED in figure 15.9. The ac control versions can also be dc controlled by half-wave rectifying. AC input SSRs are slower to switch on due to the time it takes for the ac signal to increase in magnitude, to be rectified, and filtered to a useful dc current level for the opto-coupler input LED.

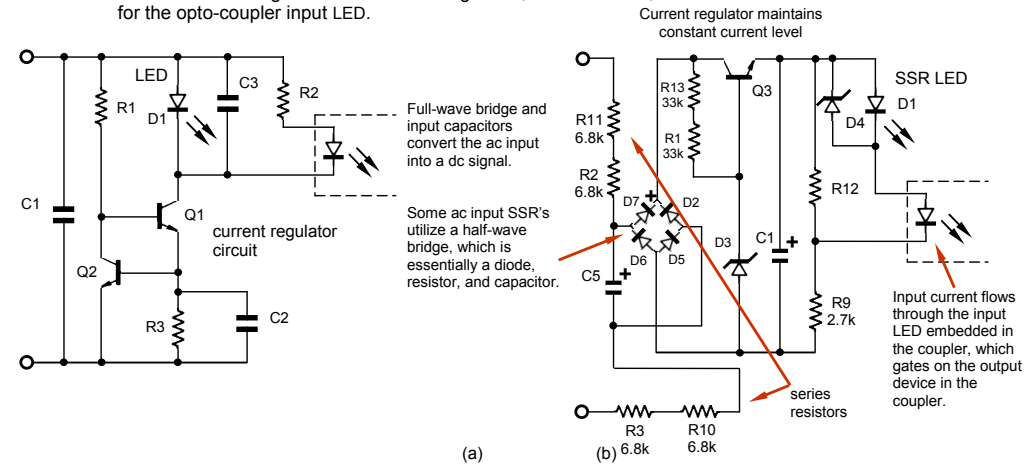

Figure 15.10. SSR input control stage for: (a) regulated dc input circuit and (b) regulated ac input circuit control.

15.1.3ii Key power elements in solid-state relays

In most power electronics cases, back-to-back SCRs are used as the output elements of ac output solid-state relays. The back-to-back SCR configuration shown in figure 15.8 has performance advantages when compared with triac outputs, notably higher dv/dt . Triacs have a dv/dt limitation when turning off: the commutating dv/dt of a triac is of the order of $10V/\mu s$. Back-to-back SCRs do not have a commutating dv/dt limitation, just a critical dv/dt which is greater than $500V/\mu s$. Using two output elements (anti-parallel connected, back-to-back SCRs) offers thermal benefits compared with a single triac as the heat dissipated is spread over a wider area of the SSR package substrate ceramic insulator. Although the aluminium oxide ceramic substrate used to isolate the solid-state relay from the copper base plate is a good compromise as a thermal conductor, it has its limitations. The ceramic substrate does not efficiently conduct heat laterally, so by separating the heat source into two elements, more of

the substrate is used to conduct the heat vertically through the thickness of the ceramic. Additionally, the two SCRs are attached to their own substantial copper bus-bar lead frames, which further help to spread the heat over a larger area of the ceramic substrate. Even with the extensive use of copper lead frames to spread the heat, the ceramic substrate is the dominant source of thermal impedance, contributing approximately 50% to the total thermal impedance of the relay, from SCR chip to relay copper base-plate.

The back-to-back SCR approach is preferred if the relay is subjected to surge currents, because each element is isolated from its partner both thermally and electrically (conduction 180° apart), unlike in a single element triac output. The control circuit determines turn-on and turn-off characteristics, but it is the output silicon switch that is the key to SCR performance.

The smaller the SCR die, the lower the cost, but this also results in poorer performance, where the surge (or overload) current is reduced, plus power dissipation and thermal impedance are increased. Reducing the thickness of the silicon can marginally increase surge current rating, the forward voltage drop and, therefore, power dissipation will also be reduced. However, with thinner die, the SCR chip manufacturer experiences yield penalties owing to increased wafer breakage and lower blocking voltage yield, resulting in higher overall manufacturing cost. The blocking voltage of thinner SCR dies will be lower, making the final solid-state relay significantly more susceptible to transient overvoltage damage. This is especially true if the thickness is reduced such that SCR break-over is not due to avalanche break-over but due to punch-through breakdown. If the silicon is susceptible to punch-through breakdown, which is more likely at sub-zero temperatures, any overvoltage will destroy the SCR die, whereas in avalanche breakdown, the SCR will normally self turn-on, conduct for the remainder of the half cycle and then return to its normal blocking condition, undamaged. Thicker silicon die will generally be more rugged relative to overvoltage transients and have a higher blocking voltage rating. The forward voltage drop will be higher, resulting in higher power dissipation and lower surge current capability. The overall die yield will be higher due to less wafer breakage and a higher useful voltage yield, resulting in lower manufacturing cost.

Optimized SCR design also involves considerations such as gate current and voltage to fire, holding current, latching current, and dv/dt capability.

15.1.3iii Solid-state relay overvoltage fault modes

AC output solid-state relays operate in a wide variety of electrical environments. Some are benign with well-regulated and controlled ac supply lines, unlike others that are hostile with switching transients from a wide variety of sources. These transients can range from insignificant low-voltage, low-energy levels to high-voltage, high-energy pulses. Provided the amplitude of any line-borne voltage transients are below the rated transient voltage of the solid-state relay, safe reliable operation ensues.

For relays, generally, these transient voltage ratings are 600V peak for 240V rms rated relays and 1,200V peak for 480V rms rated relays. However, if a relay's transient voltage rating is exceeded, the relay may be damaged. Generally the relay will break over into uncontrolled conduction and recover at the next current zero with no damage. In other cases, depending on the frequency of break-over and the voltage capability of the various semiconductor elements that are exposed to the transient, the relay can be permanently damaged.

Two control circuits used in the ac output of solid-state relays are shown in Figure 15.9.

In the circuit in Figure 15.9b, seven elements are exposed to the ac line voltage: two output SCRs, four diodes in the bridge rectifier, and the pilot SCR. Of these seven elements, if the lowest break down voltage is the reverse voltage of one of the output SCRs or a bridge diode, any overvoltage transient will permanently damage this element. The result will be a solid-state relay permanently on. If the lowest voltage breakdown voltage is the forward blocking voltage of any of the three SCRs, the SCR will likely break over into conduction without damage. The relay will conduct until the next current zero, then turn off and continue to operate normally. In practice, the lowest voltage breakdown element is normally the pilot SCR (SCR3), which is only forward biased, so it breaks over into conduction and turns on an output SCR (SCR1 or SCR2) through its gate, which is the normal turn-on mechanism for the main SCRs. The relay conducts until the next current zero and then regains control.

In Figure 15.10a, three elements are exposed to the ac line voltage: the output SCRs (SCR1 and SCR2) and the opto-triac Q_p . If the lowest breakdown voltage level is the reverse voltage of one of the output SCRs, then any over voltage transient will damage it and the relay output will be permanently on. If the lowest breakdown voltage is the forward voltage of one of the output SCRs, it will likely break over into conduction without damage. The relay will conduct until the next current zero, turn off and function normally. If the lowest breakdown element is the opto-triac, Q_p , it will probably break over into conduction, turning on an output SCR (SCR1 or SCR2) through its gate, which is the normal turn-on sequence for the main SCRs. The break-over current through Q_p is limited by the series resistor R3. If Q_p is repeatedly broken over into conduction, it will eventually fail, resulting in permanently on the relay.

15.1.3iv Transient voltage protection device requirements for an SSR (also see Chapter 12.4.1i)

MOVs and transorb are commonly used transient voltage protection devices, in both ac and dc circuits. See Chapter 12.4.

- An MOV is a metal oxide varistor which is made from a metal oxide material, typically zinc oxide, and it dissipates energy in the grain structure of the device. It switches into conduction relatively slowly, but can dissipate large levels of energy.
- A Transient Voltage Suppressor, TVS, or transorb is made from traditional semiconductor silicon material and switches fast. It can handle large amounts of power, but only for short periods (low energy). It is like a Zener diode and is used to protect electronic devices from transients. A Transorb functions by clamping any excessive voltage to a specific limit. It does this by conducting when excessive voltage is impressed across its two terminals. For a short time, the transorb absorbs high power. The transorb also reacts within a few nanoseconds, making it superior to any traditional transient protection solution.

An MOV can be used to protect an SSR from transients, which can cause the SSR to turn-on without a control voltage applied. An MOV is typically placed externally, in parallel with the output of the SSR, as shown in figure 15.9a. After an MOV reaches its life expectancy, it typically fails shorted. By contrast, a transorb typically does not fail shorted, rather fails open, and is normally installed within the SSR.

MOVs are widely used to protect voltage-sensitive elements from overvoltage transients. The MOV has a voltage dependant resistance so that as the voltage increases, its impedance changes from a high resistance to a lower value at some specified voltage. The slope resistance of the characteristic is high, so that in the event of a high current pulse, it can be difficult to coordinate and discriminate the MOV clamping voltage, the protected device voltage rating, and the system operating voltage. However, MOVs are available in a variety of energy absorbing sizes (Joule rating) so that a suitable compromise can be made.

A significant MOV feature is its wear-out mechanism: every time it absorbs transient energy, its characteristics are changed, normally by the clamping voltage being reduced. Obviously if the MOV clamping voltage degrades to the point where it overlaps the supply voltage, then it will overheat and create a potentially hazardous over-temperature condition. For this reason, MOVs are usually oversized and used with caution.

Where transient energy levels are known and are of limited magnitude, the better option is to use TVS clamping diodes or break-over diodes. Both are silicon semiconductor devices with no deterioration mechanism but in modest sizes and costs, they cannot absorb the same amount of energy as an equivalent MOV. The TVS diode exhibits high impedance until its clamping voltage is reached and then essentially goes into a controlled avalanche mode with a low slope resistance. The break-over (or crowbar) diode exhibits a high impedance until its break-over voltage is reached and then breaks down to a low impedance (hence low voltage), thus protecting against high voltage transients.

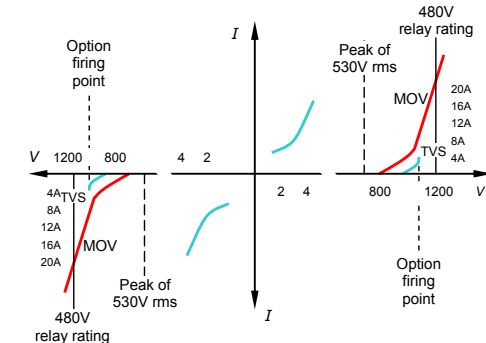

Figure 15.11. Voltage-Current characteristic curves for MOVs, break-over diodes, and TVSs.

Figure 15.11 shows the various voltage levels associated with the protection of a 480V ac solid-state relay, which has a maximum rms voltage rating of 530V, resulting in a peak voltage of approximately 750V, as shown on Figure 15.11. Solid-state relays rated at 480V rms are normally tested at three times this level, 1,200V peak, shown as the '480V relay rating' in Figure 15.11. A typical MOV clamping curve is shown, starting to clamp at about 900V but with a relatively high resistive component taking the clamping voltage above the relay rating if the voltage transient can supply about 21A peak.

Also shown in Figure 15.11, 1100V is the typical breakdown voltage of the type of TVS that is used to protect a relay. The current internal to the TVS will not reach the 4A shown, indicating the much lower

slope resistance of TVS protectors. In most cases, the internal TVS diode will trigger the relay before the TVS current reaches 100mA. Although this energy level may appear high, it is spread over a number of series TVS elements, which yield excellent thermal management and dissipation paths.

Figure 15.9 shows the SSR output stage protected by an external parallel-connected RC snubber circuit. An RC snubber is more effective for dv/dt suppression than for transient over-voltage protection. The snubber losses, CV^2 , are higher than those in MOV type protection, since the RC snubber is active during normal ac operation, as opposed to only being functional during a transient over-voltage situation in the MOV case. The energy associated with the MOV capacitance continually being cycled, limits its upper operating frequency.

15.1.3v Solid-state relay internal protection methods

Because of the problems associated with MOVs, particularly the possibility of over heating and lifetime clamping voltage downward drift, solid-state relays tend to be supplied without internal MOVs.

Certain applications may employ TVS diodes (as shown by the dotted line connections in the two parts of Figure 15.9), connected to the gates of the output SCRs, which will conduct at voltages above maximum line voltage and below the voltage rating of the solid-state relay. If a transient voltage occurs, the TVS diodes conduct and normal gate current flows into the gates of the output SCRs, and the forward biased SCR turns on. This is the standard turn-on sequence for the solid-state relay output SCRs; they are turned on by the normal injection of gate current and no component is overstressed.

This internal overvoltage protection is available on specific solid-state relays.

- Generally, for resistive loads TVS over-voltage protection is suitable, provided the load can tolerate the transfer of the transient to the load.
- For capacitive loads, it is inadvisable to use internal TVS protection as this could lead to high inrush (surge) currents and possibly latent or catastrophic di/dt failures.
- In some motor start and stop applications TVS protection may be suitable depending on the motor load, the effects of a sudden, undesired small movement of the motor, etc. This form of protection cannot be used with motor reversing applications. This poses the significant danger of two relays (for forward and reverse operation) being turned on by a transient, resulting in a line-to-line short that damages the relays and other circuit elements.

15.1.3vi Application considerations

Different applications require different solid-state relay characteristics. Generally, the two turn-on methods, zero-crossing (for minimum EMC) or instantaneous, have specific application areas. However, there are general guidelines governing when either should be used, or not used.

If the load requires proportional control every ac half cycle (such as incandescent lamp dimming or low thermal mass temperature control), the instantaneous turn-on type is used. For high thermal mass loads, a zero-crossing relay with complete cycles of conduction and non-conduction is usually the preferred method of temperature control. A zero-crossing relay is generally used for inductive loads. However, for these types of loads a random turn-on type should always be considered. Under certain low load current and low power factor conditions it is possible for a zero-crossing relay to conduct only on every other half cycle (half-waving). This is caused by the relay terminal voltage rising so rapidly through the zero cross voltage window (at the lagging current zero) that the relay control circuit does not have time to react and so is locked off until the next voltage zero. With a random turn-on SSR type, there is no zero crossing window so no possibility of the relay half-waving. If in doubt, use a random turn-on relay for inductive loads.

Minimum load current is the least conducting current that the SSR will switch on and continue to carry with a nominal output voltage drop. Load currents less than this (latching and holding current) value, typically 50 to 100mA, may not be switched by the SSR.

The most common failure mode of an SSR is a shorted output, either half-wave or fully shorted, caused by excess load current flow or over temperature. The most common end of life failure is an open circuit as a result of thermal fatigue of internal solder joints and the substrate.

In general, the best means to avoid such failures or to prolong the life of an SSR, is to operate at the lowest possible temperature and avoid large temperature excursions. Applications that have repetitive current surges should employ a higher current rated SSR to accommodate surge heating.

Example 15.3: Solid-state relay turn-on

Calculate the expected turn-on (trigger) voltage of an ac output SSR using SCRs and a trigger circuit, as in figure 15.9a, with the following parameters:

$$I_{gt} = 50\text{mA, for both SCRs (minimum gate current for turn-on at } 25^\circ\text{C)}$$

$$V_{gt} = 0.7\text{V for each SCR (minimum gate voltage for turn-on at } 25^\circ\text{C)}$$

Single opto-coupler with 1.0V V_f drop
Trigger circuit impedance of 68 Ω .
No R_{gk} resistor.

Solution

With the aid of figure 15.9a:

Trigger circuit drop: 50mA x 68 Ω = 3.4V.

SCR gate drops: 0.7V x 2 = 1.4V.

The expected turn-on (trigger) voltage: 3.4V + 1.4V + 1.0V coupler drop = 5.8V.

This turn on or trigger voltage constitutes the lower value of the zero turn-on 'window'.

Example 15.4: Solid-state relay heatsink requirements

A solid-state relay carries 50A in an application with a forward voltage drop V_f of 1.1V pk, resulting in 55W of power being dissipated. The ambient temperature is 35 $^\circ\text{C}$, giving a 45 $^\circ\text{C}$ difference between ambient and the maximum recommended base plate temperature of 80 $^\circ\text{C}$. What is the heat-sinking requirement?

Solution

Division of the 45 $^\circ\text{C}$ temperature differential by the 55W of power being dissipated, results in a 0.82 $^\circ\text{C/W}$ heat sink requirement for the application. Prudently, 0.1 $^\circ\text{C/W}$ is deduced from the result to account for the thermal compound used in the assembly. Therefore, a 0.82 $^\circ\text{C/W}$ heat sink less 0.1 $^\circ\text{C/W}$ is 0.72 $^\circ\text{C/W}$.

The heat sink needed requires a thermal resistance of no more than 0.7 $^\circ\text{C/W}$.

15.1.3vii DC output solid-state relays

DC output SSRs rated to 400V dc are usually MOSFET output based, while 1000V dc, 25A SSRs have an IGBT output stage. Both dc SSR types are usually dc input controlled. DC output solid-state relays are used for switching dc since, unlike dc electromechanical relays, there are no moving parts, hence no contact arcing or wear-out mechanism. However, there are some precautions, which have to be assessed when using dc output solid-state relays with inductive dc loads.

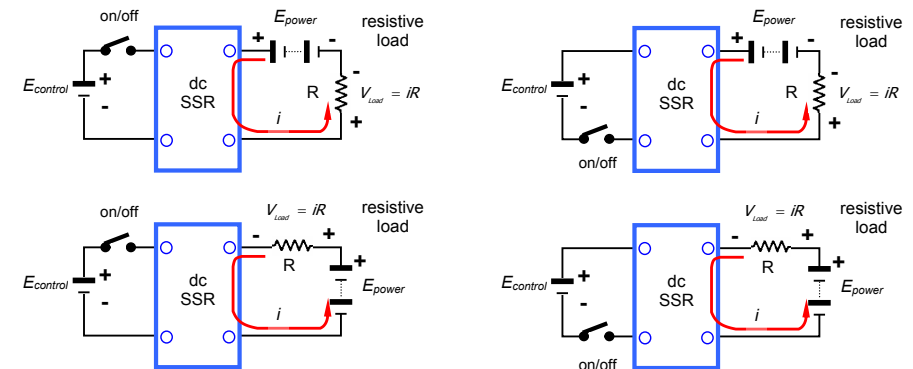

Figure 15.12. Control and load connection possibilities for dc output solid-state relays.

Relay Connections

Because the input and output terminals of dc solid-state relays are electrically isolated by up to 3,750V rms, the relative electrical potentials of the input signal and load connections are irrelevant. As shown in Figure 15.12, the input can be supplied either from a source or sink configuration and the load can be connected to either the relay positive or negative output terminals. The solid-state relay can be used as a level shifter because no electrical relationship is required between the input control and power output sections of the relay.

Inductive Load Considerations

When the dc load is inductive, precautions have to be taken to protect the solid-state relay at turn off. Energy is stored in the magnetic flux created by the current flowing through the inductive load. When the solid-state relay is turned off the collapse of the magnetic flux $d\Phi/dt$ creates an electro-magnetic force with a polarity that tries to maintain the pre-existing current flow. This is shown schematically in Figure 15.13.

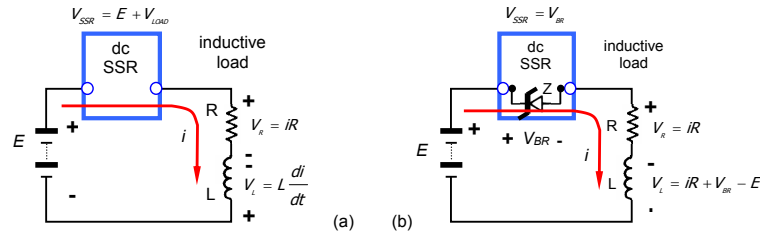

Figure 15.13. Inductive loads with dc solid-state relays: (a) circuit connection and (b) induced voltages at turn-off.

If no electrical path is provided for the inductive load current to flow, the rapid collapse of magnetic flux will generate a voltage high enough to break-over any limiting voltage element in the output load circuit. One element is usually the solid-state relay, shown schematically as V_{BR} . In the case of a solid-state relay, either the output power semiconductor device or one of the driving semiconductors will break-over into conduction, which may permanently damage the semiconductor resulting in a relay with a permanently shorted output. In most dc circuits, a circulating (freewheeling) path for the inductive current can be created by the addition of a freewheel diode as shown in Figure 15.14a.

Unless the solid-state relay is to be turned on while current is still flowing in the freewheel diode, the diode can be a standard recovery type. If, however, the solid-state relay may need to turn on before the load current has been completely decayed to zero, then a fast recovery diode must be used in the freewheel position. The use of a fast recovery diode reduces the instantaneous reverse recovery inrush current amplitude and duration when the relay is turned on into an existing freewheel diode current.

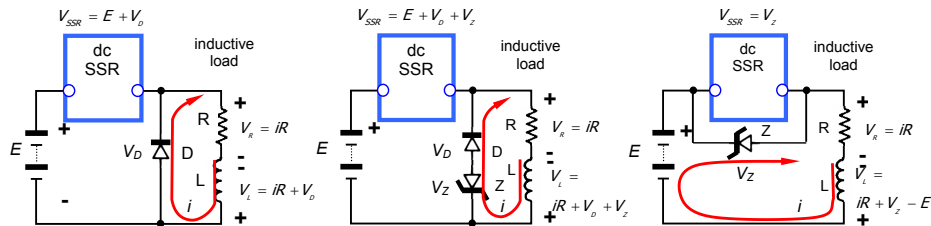

Figure 15.14. The dc output SSR with an inductive load incorporating: (a) a load freewheel diode; (b) load diode/Zener diode combination; and (c) a Zener diode across the dc SSR output alternative.

Generally, it is necessary to collapse the inductive current rapidly, for example, to open a solenoid as quickly as possible. If rapid current discharge is a requirement, then the discharge path must be designed with a high voltage generated. This follows from the fact $E = L di/dt$, where E is the voltage generated by the collapse of magnetic flux, L is the inductance of the load and di/dt is the rate of change of current. The greater the value of E , for a fixed value of load L , then the greater the di/dt and the more rapidly the load current is reduced to zero. Increasing the voltage, which has to be generated to create a freewheel path, can be accomplished by adding to the diode shown in Figure 15.14a, a series Zener or TVS diode as shown in Figure 15.14b. The voltage appearing across the solid-state relay is the sum of the supply voltage and the Zener or TVS diode voltage. So for a system using a dc supply of E and a solid-state relay voltage rated at V_R , the voltage across the freewheel components cannot be greater than $V_{BR} - E$ at maximum load current.

An alternate method to create the same inductor voltage is to connect the Zener or TVS diode externally across the output terminals of the solid-state dc relay, as shown in figure 15.14c (and internally in figure 15.13b). In this case the clamping voltage can be V_{BR} , the voltage rating of the dc SSR. As this voltage is in series with the dc supply E , the net result is the same as putting the clamping component across the load, a voltage of $V_{BR} - E$ is generated by the inductive load. The energy loss in the clamping device

is greater in this case, since the freewheel path involves energy being drawn from the dc source. However, importantly, the voltage clamping protection is directly across the primary component to be protected, viz., the SSR, and even better if placed inside the SSR module as shown in figure 15.14b.

15.2 Single-phase transformer tap-changer – line commutated

Figure 15.15 shows a single-phase tap changer using two ac output solid-state relays, where the tapped ac voltage supply can be provided by a tapped transformer or autotransformer.

Thyristor T_3 (T_4) is triggered at zero voltage cross-over (or later), subsequently under phase control T_1 (T_2) is turned on, thereby commutating T_3 (T_4). The output voltage (and current) for a resistive load R is defined by

$$v_o(\omega t) = i_o(\omega t) \times R = \sqrt{2} V_2 \sin \omega t \quad (\text{V}) \quad (15.57)$$

for $0 \leq \omega t \leq \alpha$ (rad)

$$v_o(\omega t) = i_o(\omega t) \times R = \sqrt{2} V_1 \sin \omega t \quad (\text{V}) \quad (15.58)$$

for $\alpha \leq \omega t \leq \pi$ (rad)

where α is the phase delay angle and $v_2 < v_1$.

If $0 \leq \beta = V_2/V_1 \leq 1$, then for a resistive load the rms output voltage is

$$V_{rms} = \left[\frac{V_2^2}{\pi} (\alpha - \frac{1}{2} \sin 2\alpha) + \frac{V_1^2}{\pi} (\pi - \alpha + \frac{1}{2} \sin 2\alpha) \right]^{1/2} = V_1 \left[\left\{ 1 - \frac{1}{\pi} (1 - \delta^2) (\alpha - \frac{1}{2} \sin 2\alpha) \right\} \right]^{1/2} \quad (15.59)$$

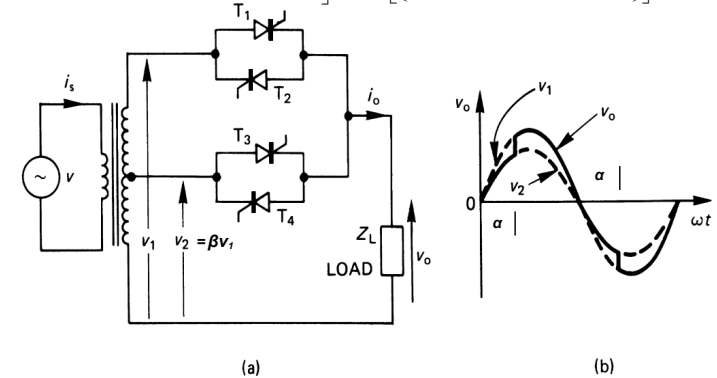

Figure 15.15. An ac voltage regulator using a tapped transformer: (a) circuit connection and (b) output voltage waveform with a resistive load.

The Fourier coefficients of the output voltage, which has only odd harmonics, are

$$a_n = V_1 \frac{2}{\pi} \frac{1 - \beta}{1 - \beta^n} [\cos \alpha \cos n\alpha + n \sin \alpha \sin n\alpha - 1] \quad (15.60)$$

$$b_n = V_1 \frac{2}{\pi} \frac{1 - \beta}{1 - \beta^n} (\cos \alpha \sin n\alpha - n \sin \alpha \cos n\alpha)$$

The amplitude of the fundamental quadrature components, $n = 1$, are

$$a_1 = V_1 \frac{1}{\pi} (1 - \beta) \sin^2 \alpha \quad (15.61)$$

$$b_1 = V_1 \frac{1}{\pi} (1 - \beta) (\alpha \sin^2 \alpha - \cos^2 \alpha - \sin \alpha \cos \alpha)$$

Initially v_2 is impressed across the load, via T_3 (T_4). Turning on T_1 (T_2) reverse-biases T_3 (T_4), hence T_3 (T_4) turns off and the load voltage jumps to v_1 . It is possible to vary the rms load voltage between v_2 and v_1 . It is important that T_1 (T_2) and T_4 (T_3) do not conduct simultaneously, since such conduction short-circuits the transformer secondary.

Both load current and voltage information (specifically zero crossing) is necessary with inductive and capacitive loads, if winding short circuiting is to be avoided.

With an inductive load circuit, when only T_1 and T_2 conduct, the output current is

$$i_o = \frac{\sqrt{2}V}{Z} \sin(\omega t - \phi) \quad (\text{A}) \quad (15.62)$$

$$\text{where } Z = \sqrt{R^2 + (\omega L)^2} \quad (\text{ohms}) \quad \phi = \tan^{-1} \omega L / R \quad (\text{rad})$$

It is important that T_3 and T_4 are not fired until $\alpha \geq \phi$, when the load current must have reached zero. Otherwise a transformer secondary short circuit occurs through T_1 (T_2) and T_4 (T_3). For a resistive load, the thyristor rms currents for T_3 , T_4 and T_1 , T_2 respectively are

$$I_{T_{rms}} = \frac{V_2}{\sqrt{2}R} \sqrt{\frac{1}{\pi} (2\alpha - \sin 2\alpha)} \quad (15.63)$$

$$I_{T_{rms}} = \frac{V_1}{\sqrt{2}R} \sqrt{\frac{1}{\pi} (\sin 2\alpha - 2\alpha) + 2\pi}$$

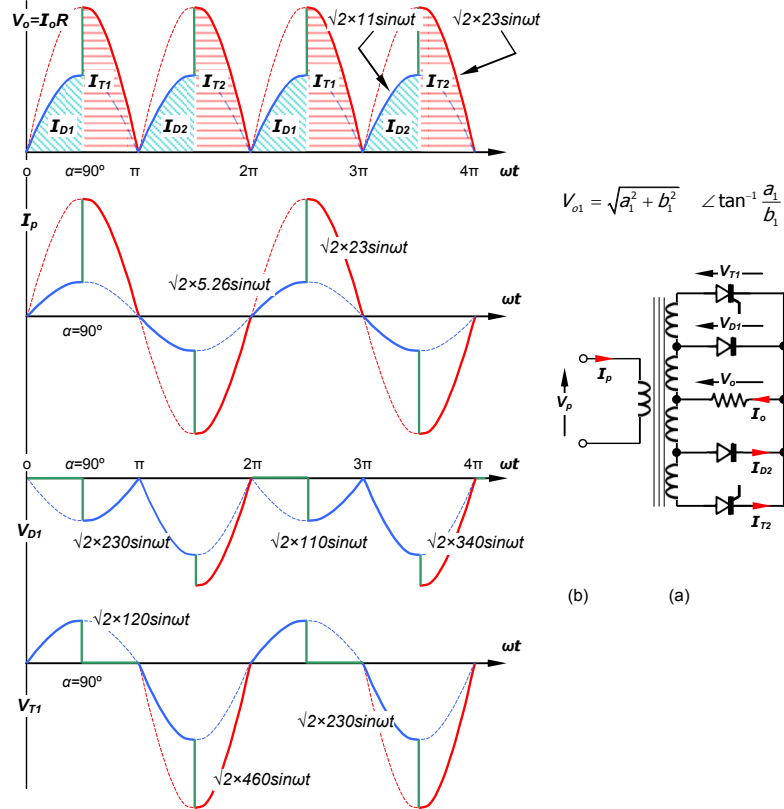

Figure 15.16. An ac voltage regulator using a tapped transformer connected as a rectifier with a resistive load: (a) circuit diagram and symbols and (b) circuit waveforms, viz., output voltage and current, transformer primary current, diode reverse blocking voltage, and thyristor blocking voltages.

The thyristor voltages ratings are both $v_1 - v_2$, provided a thyristor is always conducting at any instant. An extension of the basic operating principle is to use phase control on thyristors T_3 and T_4 as well as T_1 and T_2 . It is also possible to use tap-changing in the primary circuit. The basic principle can also be extended from a single tap secondary to a multi-tap transformer.

The basic operating principle of any multi-output tap changer, in order to avoid short circuits, independent of the load power factor is

- switch up in voltage when the load V and I have the same direction, delivering power
- switch down when V and I have the opposite direction, returning power.

Example 15.5: Tap changing converter

The converter circuit shown in figure 15.16 is a form of ac to dc tap changer, with a 230V ac primary. The inner voltage taps can deliver 110V ac while the outer tap develops 230V ac across the 10 Ω resistive load. If the thyristor phase delay angle is 90 $^\circ$ determine:

- The mean load voltage hence mean load current
- The average diode and thyristor current
- The primary rms current
- The peak thyristor and diode voltage, for any phase angle

Solution

The output voltage is similar to that shown in figure 15.15b, except rectified, and $\alpha = 90^\circ$.

- The mean load voltage can be determine from equation (15.22)

$$V_o = \frac{\alpha}{\pi} \frac{\sqrt{2}V_{110}}{\pi} (1 + \cos 0^\circ) + \frac{\sqrt{2}V_{230}}{\pi} (1 + \cos \alpha)$$

$$= \frac{1/2\pi}{\pi} \frac{\sqrt{2}110V}{\pi} (1 + \cos 0^\circ) + \frac{\sqrt{2}230V}{\pi} (1 + \cos 90^\circ)$$

$$= 49.5V + 103.5V = 153V$$

$$\text{whence } \bar{I}_o = \frac{V_o}{R} = \frac{153V}{10\Omega} = 15.3A$$

- The diode current is associated with the 49.5V component of the average load voltage, while the thyristor component is 103.5V. Taking into account that each semiconductor has a maximum duty cycle of 50%:

The average diode current is

$$\bar{I}_D = 50\% \times \frac{49.5V}{10\Omega} = 2.475A$$

The average thyristor current is

$$\bar{I}_T = 50\% \times \frac{103.5V}{10\Omega} = 5.175A$$

- The primary rms current has two components.

When the diode conducts, the primary current is

$$i_{p1} = \sqrt{2} \frac{110V}{230V} \times \frac{110V}{10\Omega} \sin \omega t = \sqrt{2} \times 5.26 \sin \omega t \quad 0 \leq \omega t \leq \alpha$$

$$i_{p2} = \sqrt{2} \frac{230V}{230V} \times \frac{230V}{10\Omega} \sin \omega t = \sqrt{2} \times 23 \sin \omega t \quad \alpha \leq \omega t \leq \pi$$

The rms of each component, on the primary side, is

$$I_{msD} = \left[\frac{1}{2\pi} \int_0^\alpha (\sqrt{2} \times 5.26)^2 \sin^2 \omega t d\omega t \right]^{1/2}$$

$$= \sqrt{2} \times 5.26 \left[\frac{1}{4\pi} \{ \alpha - \frac{1}{2} \sin 2\alpha \} \right]^{1/2} = \sqrt{2} \times 5.26 \left[\frac{1}{2\sqrt{2}} \right] = 2.63A$$

$$I_{msT} = \left[\frac{1}{2\pi} \int_\alpha^\pi (\sqrt{2} \times 23)^2 \sin^2 \omega t d\omega t \right]^{1/2}$$

$$= \sqrt{2} \times 23 \left[\frac{1}{4\pi} \{ (\pi - \alpha) + \frac{1}{2} \sin 2\alpha \} \right]^{1/2} = \sqrt{2} \times 23 \left[\frac{1}{2\sqrt{2}} \right] = 11.5A$$

The total supply side rms current comprised the contribution of two diodes and two thyristors

$$I_p = \sqrt{I_{msD}^2 + I_{msD}^2 + I_{msT}^2 + I_{msT}^2}$$

$$= \sqrt{2.63^2 + 2.63^2 + 11.5^2 + 11.5^2} = 16.68A$$

- The peak diode voltage is associated with the turn-on of the thyristor associated with the other half cycle of the supply and worst case is when $\alpha < 1/2\pi$.

$$\hat{V}_D = \sqrt{2} \times 230V + \sqrt{2} \times 110V = 466.7V$$

and $466.7 \times \sin \alpha$ for $\alpha > 1/2\pi$.

The thyristor peak forward and reverse voltages are experienced at $\alpha = \frac{1}{2}\pi$:

$$\hat{V}_r^f = \sqrt{2} \times (230V - 110V) = 169.7V$$

$$\hat{V}_r^R = 2 \times \sqrt{2} \times 230V = 650.5V$$

The thyristor forward voltage is controlled by its associated diode and is less than 169.7V if $\alpha < \frac{1}{2}\pi$, viz. $169.7 \times \sin\alpha$. The peak reverse voltage of 650.5V is experienced if the complementary thyristor is turned on before $\alpha = \frac{1}{2}\pi$, otherwise the maximum is $650.5 \times \sin\alpha$ for $\alpha > \frac{1}{2}\pi$.



15.3 Single-phase ac chopper regulator – commutable switches

15.3.1 Single-phase ac chopper regulator – version #1

An ac step-down chopper is shown in figure 15.17a. The switches T_1 and T_3 (shown as reverse blocking IGBTs) impress the ac supply across the load while T_2 and T_4 provide load current freewheel paths when the main switches T_1 and T_3 are turned off. In order to prevent the supply being shorted, switches T_1 and T_4 can not be on simultaneously when the ac supply is in a positive half cycle, while T_2 and T_3 can not both be on during a negative half cycle of the ac supply. Zero voltage information is necessary. If the rms supply voltage is V and the on-state duty cycle of T_1 and T_3 is δ , then rms output voltage V_o is

$$V_o = \delta V \quad (15.64)$$

When the sinusoidal supply is modulated by a high frequency rectangular-wave carrier ω_s ($2\pi f_s$), which is the switching frequency, the ac output is at the same frequency as the supply f_o but the fundamental magnitude is proportional to the rectangular wave duty cycle δ , as shown in figure 15.17b. Being based on a modulation technique, the output harmonics involve the fundamental at the supply frequency f_o and components related to the high frequency rectangular carrier waveform f_s . The output voltage is given by

$$V_o = \sqrt{2}\delta V \sin \omega_o t + \sum_{\forall n=1} \left[\frac{\sqrt{2}V}{n} \sin n\delta \left\{ \sin(\omega_o + n\omega_c)t - \sin(\omega_o - n\omega_c)t \right\} \right] \quad (15.65)$$

The carrier (switching frequency) components can be filtered by using an output L-C filter, as shown in figure 15.17a, which has a cut-off frequency of $f_{1/2}$ complying with $f_o < f_{1/2} < f_s$.

Rather than using a variable duty cycle to control the output magnitude, selective harmonic elimination, SHE, can be used, where the switches are commutated at pre-calculated angles so as to eliminate specific harmonics, and control the fundamental magnitude of the output voltage. T_1/T_3 are turned on at switching angles $\alpha_1, \alpha_3, \dots, \alpha_{M-1}$ and turned off at $\alpha_2, \alpha_4, \dots, \alpha_M$ per quarter cycle.

The quarter-wave symmetry results in null even harmonics, including any dc component. By the proper choice of PWM switching angles, α_i , the fundamental component can be controlled and selected low order harmonics can be eliminated. The Fourier series for the output voltage, which is expressed in terms of the M switching point variables per quarter cycle, is:

$$v_o = \sqrt{2}V \sum_{n=1,3,5,\dots}^{\infty} a_n \sin n\omega t$$

where the value of a_n is:

$$a_n = \frac{2}{\pi} \sum_{i=1}^M (-1)^i \left[\frac{\sin(n-1)\alpha_i}{(n-1)} - \frac{\sin(n+1)\alpha_i}{(n+1)} \right]$$

where $n = 3, 5, \dots, 2M-1$, M is the number of switching angles per quarter cycle, α_i is the i^{th} switching angle and $\sqrt{2}V$ is the maximum value of the input voltage. The rms fundamental component is given by:

$$V_{a1} = V \left(1 + \frac{2}{\pi} \sum_{n=3,5,7,\dots}^{\infty} (-1)^n [\alpha_n - \frac{1}{2} \sin 2\alpha_n] \right)$$

The commutation angle selection to eliminate certain harmonics is addressed in Chapter 15.3.4viii.

Three phase delta or star, input and output, extensions of the ac controller in Figure 15.17 are possible, thereby creating a power electronic three-phase step-down voltage transformerless variac.

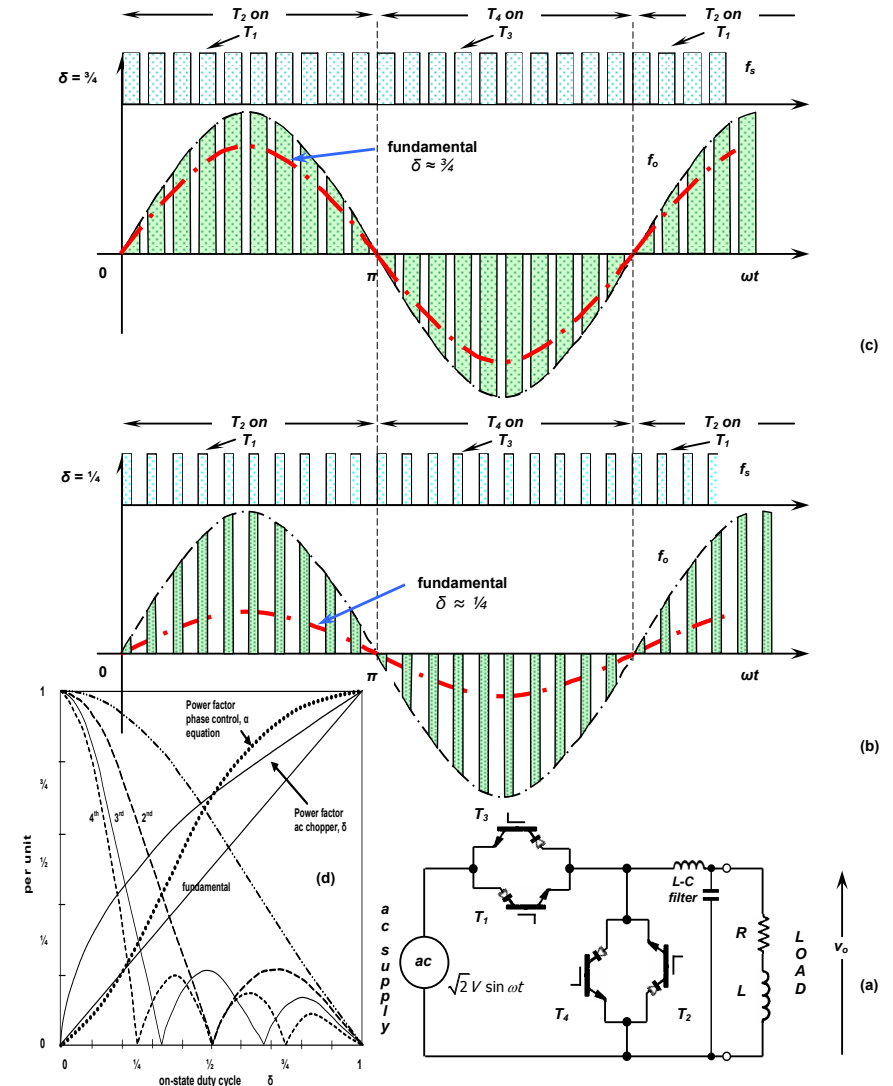

Figure 15.17. An ac voltage regulator using a chopper, with commutable switches: (a) circuit configuration and output voltage waveform with a resistive load at (b) low modulation, $\delta \approx \frac{1}{4}$; (c) high modulation, $\delta \approx \frac{3}{4}$; and (d) harmonic characteristics.

15.3.2 Single-phase ac chopper regulator – version #2

The ac chopper shown in figure 15.18a is a flexible variation of the ac chopper regulator shown in figure 15.17a. The regulated output v_o has a fixed ac component βV with a series connected, hence superimposed ac component, the magnitude of which is determined by the auto transformer (or transformer) tap. The rms output voltage can be varied between βV and V , where $0 \leq \beta \leq 1$.

The switches T_1 and T_3 (shown as reverse blocking IGBTs) impress the ac supply $\sqrt{2}V\sin\omega t$ across the load while T_2 and T_4 provide load current freewheel paths, thereby clamping the output to $\sqrt{2}\beta V\sin\omega t$, when the main switches T_1 and T_3 are turned off. In order to prevent the upper tapped transformer section being shorted, switches T_1 and T_4 can not be on simultaneously when the ac supply is in a positive half cycle, while T_2 and T_3 can not both be on during a negative half cycle of the ac supply. Zero voltage information is necessary.

If the rms supply voltage is V and the on-state duty cycle of T_1 and T_3 is δ , then rms output voltage V_o is

$$V_o = \beta V + \delta(1 - \beta)V \tag{15.66}$$

That is, the controllable rms output voltage range is $\beta V \leq V_o \leq V$ for $0 \leq \delta \leq 1$, correspondingly.

When the sinusoidal supply is modulated by a high frequency rectangular-wave carrier ω_s ($2\pi f_s$), which is the switching frequency, the ac output is at the same frequency as the supply f_o but the fundamental magnitude is proportional to the rectangular wave duty cycle δ , as shown in figure 15.18b. Being based on a modulation technique, the output harmonics involve the fundamental at the supply frequency f_o and components related to the high frequency rectangular carrier waveform f_s . The instantaneous output voltage is given by

$$v_o = \sqrt{2}(\beta V + \delta(1 - \beta)V)\sin\omega_o t + \sum_{n \neq 1} \left[\frac{\sqrt{2}(1 - \beta)V}{n} \sin n\delta \{ \sin(\omega_o + n\omega_c)t - \sin(\omega_o - n\omega_c)t \} \right] \tag{15.67}$$

The carrier (switching frequency) components can be filtered by using an output L-C filter, as shown in figure 15.18a, which has a cut-off frequency of $f_{1/2}$ complying with $f_o < f_{1/2} < f_s$. Note the filter is only across the switching section thus avoiding injecting harmonics into the section contributing a purely sinusoidal voltage component.

At higher power levels, rather than using a variable duty cycle to control the output magnitude, selective harmonic elimination, SHE, can be used, where the switches are commutated at pre-calculated angles so as to eliminate specific harmonics, and control the fundamental magnitude of the output voltage.

Three phase delta or star, input and output, extensions of the ac controller in Figure 15.17a are possible, thereby creating a power electronic three-phase step-down or step-up voltage transformerless variac.

When used in a mode where the output voltage is regulated and fixed, 110/230V ac, the supply input (that is the ac distribution voltage) can be increased, thus increasing the capacity of the local distribution system. Such a concept can take advantage of the fact that the insulation voltage limits of the local 415V distribution infrastructure is significantly under utilised (under stressed).

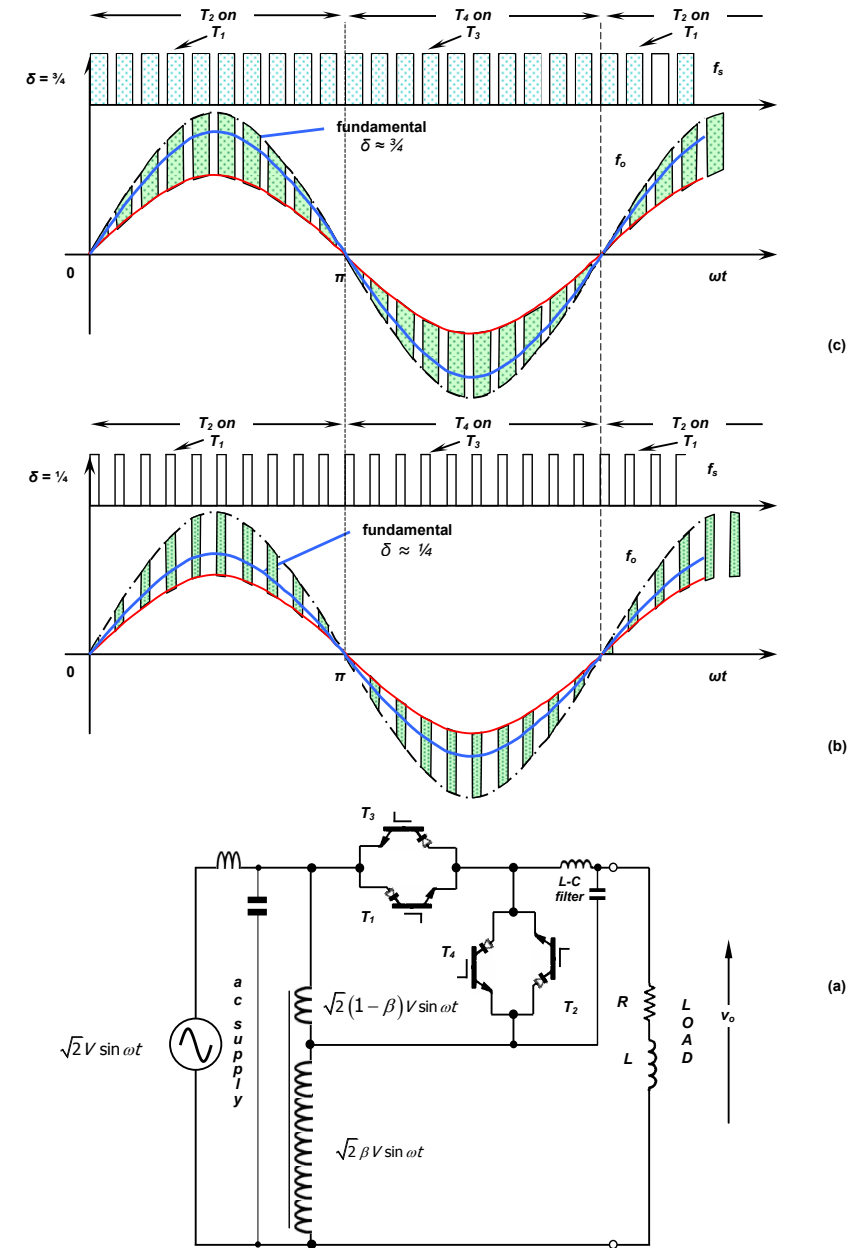

Figure 15.18. An ac voltage regulator using a chopper, with commutable switches: (a) circuit configuration and output voltage waveform with a resistive load at (b) low modulation, $\delta \approx 1/4$; and (c) high modulation, $\delta \approx 3/4$.

15.4 Three-phase ac regulator

The three-phase fully and half controlled ac to ac converters in figure 15.18x are considered in this section.

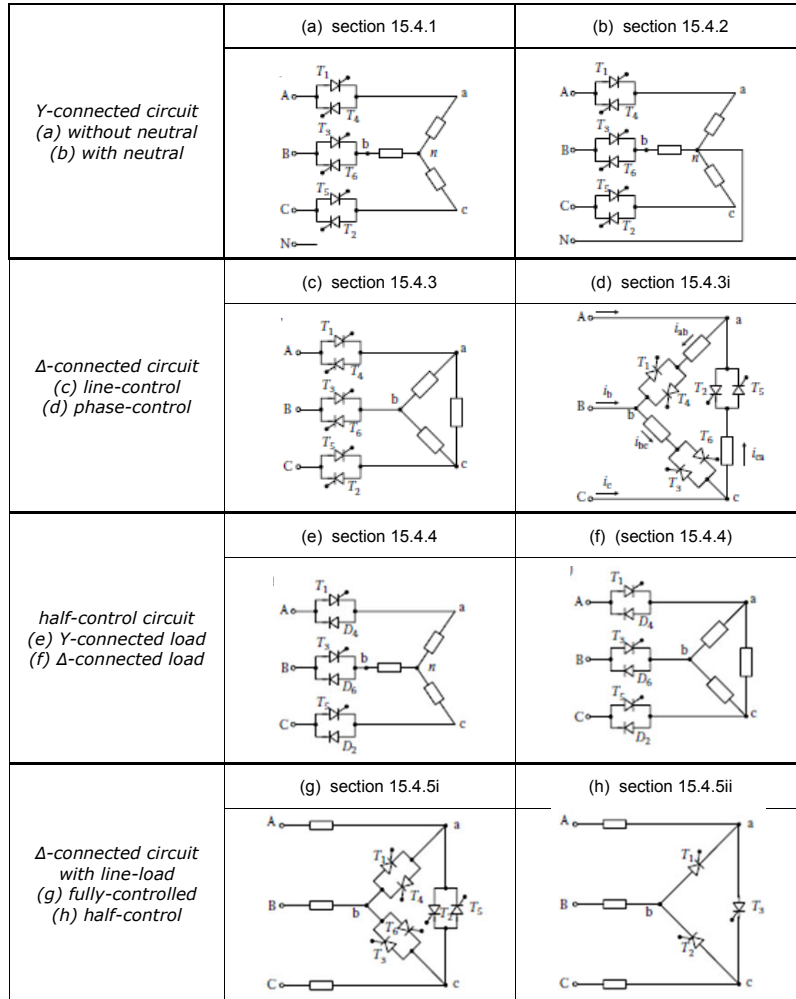

Figure 15.18x. Three phase ac to ac controlled and half controlled converters

15.4.1 Fully-controlled three-phase ac regulator with wye load and isolated neutral

The power to a three-phase star or delta-connected load may be controlled by the ac regulator shown in figure 15.19a with a star-connected load shown. The circuit is commonly used to soft start three-phase induction motors. If a neutral connection is made, load current can flow provided at least one thyristor is conducting. At high power levels, neutral connection is to be avoided, because of load triplen currents that may flow through the phase inputs and the neutral. With a balanced delta connected load, no triplen or even harmonic currents occur.

If the regulator devices in figure 15.19a, without the neutral connected, were diodes, each would conduct for $\frac{1}{2}\pi$ in the order T_1 to T_6 at $\frac{1}{6}\pi$ radians apart. As thyristors, conduction is from α to $\frac{1}{2}\pi$.

a. Purely resistive load

In the fully controlled ac regulator of figure 15.19a without a neutral connection, at least two devices must conduct for power to be delivered to the load. The thyristor trigger sequence is as follows. If thyristor T_1 is triggered at α , then for a symmetrical three-phase load voltage, the other trigger angles are T_3 at $\alpha + \frac{2}{3}\pi$ and T_5 at $\alpha + 4\pi/3$. For the antiparallel devices, T_4 (which is in antiparallel with T_1) is triggered at $\alpha + \pi$, T_6 at $\alpha + 5\pi/3$, and finally T_2 at $\alpha + 7\pi/3$.

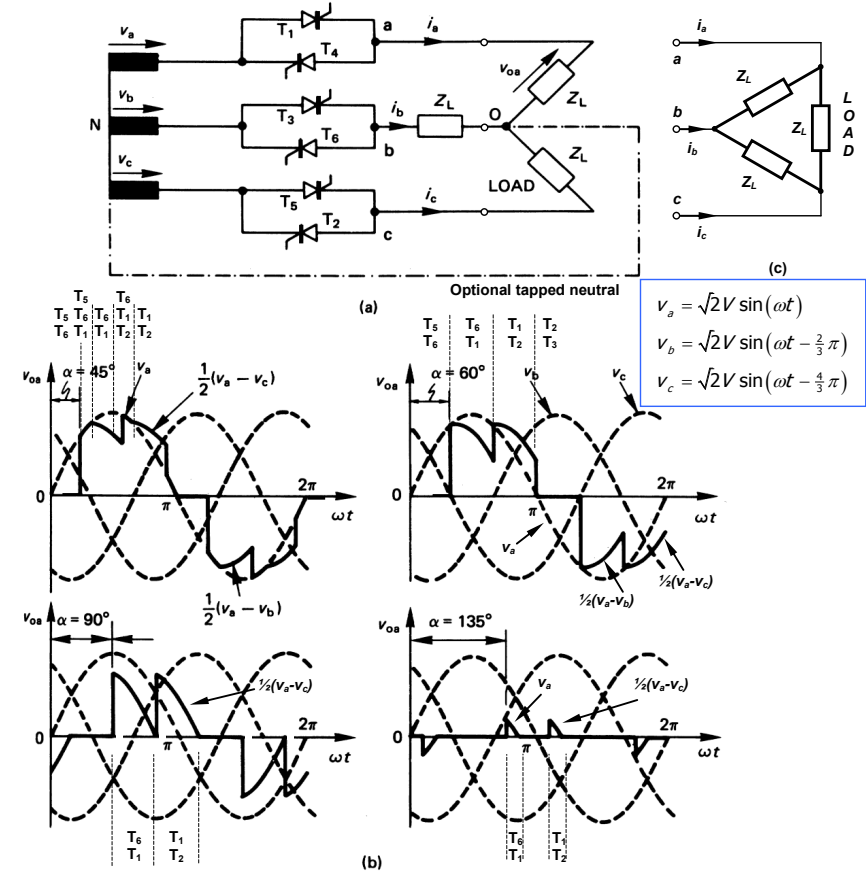

Figure 15.19. Three-phase ac full-wave voltage controller: (a) circuit connection with a star load; (b) phase a, line-to-load neutral voltage waveforms for four firing delay angles; and (c) delta load.

Figure 15.19b shows resistive load, line-to-neutral voltage waveforms (which are symmetrical about zero volts) for four different phase delay angles, α . Three distinctive conduction periods, plus a non-conduction period, exist. The waveforms in figure 15.19b are useful in determining the required bounds of integration. When three regulator thyristors conduct, the voltage (and the current) is of the form $\frac{\sqrt{3}}{2}V \sin \phi$, while when two devices conduct, the voltage (and the current) is of the form $\frac{1}{2}V \sin(\phi - \frac{1}{6}\pi)$. V is the maximum line voltage, $\sqrt{3}\sqrt{2}V$.

- i. $0 \leq \alpha \leq \frac{1}{3}\pi$ [mode 3/2] – alternating every $\frac{1}{3}\pi$ between 2 and 3 conducting thyristors, Full output occurs when $\alpha = 0$, when the load voltage is the supply voltage and each thyristor conducts for π . For $\alpha \leq \frac{1}{3}\pi$, in each half cycle, three alternating devices conduct and one will be turned off by natural commutation. The output voltage is continuous. Only for $\omega t \leq \frac{1}{3}\pi$ can three sequential devices be on simultaneously.

Examination of the $\alpha = \frac{1}{2}\pi$ waveform in figure 15.19b shows the voltage waveform is made from five sinusoidal segments. The rms load voltage per phase (line to neutral), for a resistive load, is

$$V_{rms} = \hat{V} \left[\frac{1}{\pi} \left\{ \int_{\alpha}^{\frac{3}{2}\pi} \sin^2 \phi \, d\phi + \int_{\frac{3}{2}\pi}^{\frac{5}{2}\pi} \sin^2(\phi + \frac{1}{6}\pi) \, d\phi + \int_{\frac{5}{2}\pi}^{\frac{7}{2}\pi} \sin^2 \phi \, d\phi + \int_{\frac{7}{2}\pi}^{\frac{9}{2}\pi} \sin^2(\phi - \frac{1}{6}\pi) \, d\phi + \int_{\frac{9}{2}\pi}^{\pi} \sin^2 \phi \, d\phi \right\} \right]^{1/2}$$

$$V_{rms} = I_{rms} R = V \left[1 - \frac{3}{2\pi} \alpha + \frac{3}{4\pi} \sin 2\alpha \right]^{1/2} \quad (15.68)$$

The Fourier coefficients of the fundamental frequency are

$$a_1 = \frac{3}{4\pi} V (\cos 2\alpha - 1) \quad b_1 = \frac{3}{4\pi} V (\sin 2\alpha + \frac{4}{3}\pi - 2\alpha) \quad (15.69)$$

Using the five integration terms as in equation (15.68), not squared, gives the average half-wave (half-cycle) load voltage, hence specifies the average thyristor current requirement with a resistive load. That is

$$\bar{V}_o^{-1/2\text{cycle}} = 2 \times \bar{I}_T R = \sqrt{2} V \frac{1}{2\pi} \int_{\alpha}^{\pi} \sin \omega t \, d\omega t$$

$$= 2 \times \bar{I}_T R = \frac{\sqrt{2} V}{\pi} (1 + \cos \alpha) \quad (15.70)$$

The thyristor maximum average current is when $\alpha = 0$, that is $\hat{I}_T = \frac{\sqrt{2} V}{\pi R}$.

ii. $\frac{1}{2}\pi \leq \alpha \leq \frac{3}{2}\pi$ [mode 2/2] – two conducting thyristors

The turning on of one device naturally commutates another conducting device and only two phases can be conducting, that is, only two thyristors conduct at any time. Two phases experience half the difference of their input phase voltages, while the off thyristor is reverse biased by 3/2 its phase voltage, (off with zero current). The line-to-neutral load voltage waveforms for $\alpha = \frac{1}{2}\pi$ and $\frac{3}{2}\pi$, which are continuous, are shown in figures 15.19b.

Examination of the $\alpha = \frac{1}{2}\pi$ or $\alpha = \frac{3}{2}\pi$ waveforms in figure 15.19b show the voltage waveform is comprised from two segments. The rms load voltage per phase, for a resistive load, is

$$V_{rms} = \hat{V} \left[\frac{1}{\pi} \left\{ \int_{\alpha}^{\frac{3}{2}\pi} \sin^2(\phi + \frac{1}{6}\pi) \, d\phi + \int_{\frac{3}{2}\pi}^{\frac{5}{2}\pi} \sin^2(\phi - \frac{1}{6}\pi) \, d\phi \right\} \right]^{1/2}$$

$$V_{rms} = I_{rms} R = V \left[\frac{1}{2} + \frac{9}{8\pi} \sin 2\alpha + \frac{3\sqrt{3}}{8\pi} \cos 2\alpha \right]^{1/2} = V \left[\frac{1}{2} + \frac{3\sqrt{3}}{4\pi} \sin(2\alpha + \frac{7}{6}\pi) \right]^{1/2} \quad (15.71)$$

The Fourier co-efficients of the fundamental frequency are

$$a_1 = \frac{3}{4\pi} V (\cos 2\alpha - \cos 2(\alpha - \frac{\pi}{3})) \quad b_1 = \frac{3}{4\pi} V (\frac{2\pi}{3} + \sin 2\alpha - \sin 2(\alpha - \frac{\pi}{3})) \quad (15.72)$$

The non-fundamental harmonic magnitudes are independent of α , and are given by

$$V_h = \frac{3}{\pi(h \pm 1)} \times V \times \sin(h \pm 1) \frac{\pi}{6} \quad \text{for } h = 6k \pm 1 \quad k = 1, 2, 3, \dots \quad (15.73)$$

Using the same two integration terms, not squared, gives the average half-wave (half-cycle) load voltage, hence specifies the average thyristor current with a resistive load. That is

$$\bar{V}_o^{-1/2\text{cycle}} = 2 \times \bar{I}_T R = \sqrt{3} \sqrt{2} V \frac{1}{2\pi} \int_{\alpha}^{\frac{3}{2}\pi} \sin(\omega t + \frac{1}{6}\pi) \, d\omega t + \int_{\frac{3}{2}\pi}^{\frac{5}{2}\pi} \sin(\omega t - \frac{1}{6}\pi) \, d\omega t$$

$$= 2 \times \bar{I}_T R = \frac{\sqrt{3} \sqrt{2} V}{\pi} \sin(\alpha + \frac{1}{3}\pi) \quad (15.74)$$

iii. $\frac{3}{2}\pi \leq \alpha \leq \frac{5}{2}\pi$ [mode 2/0] – either 2 or no conducting thyristors

Two devices must be triggered in order to establish load current and only two devices conduct at anytime. Line-to-neutral zero voltage periods occur and each device must be retriggered $\frac{1}{2}\pi$ after the initial trigger pulse. These zero output periods (discontinuous load voltage) which develop for $\alpha \geq \frac{3}{2}\pi$ can be seen in figure 15.19b and are due to a previously on device commutating at $\omega t = \frac{5}{2}\pi$ then re-conducting at $\alpha + \frac{1}{2}\pi$. Except for regulator start up, the second firing pulse is not necessary if $\alpha \leq \frac{3}{2}\pi$.

Examination of the $\alpha = \frac{3}{2}\pi$ waveform in figure 15.19b shows the voltage waveform is made from two discontinuous voltage segments. The rms load voltage per phase, for a resistive load, is

$$V_{rms} = \hat{V} \left[\frac{1}{\pi} \left\{ \int_{\alpha}^{\frac{5}{2}\pi} \sin^2(\phi + \frac{1}{6}\pi) \, d\phi + \int_{\frac{5}{2}\pi}^{\frac{7}{2}\pi} \sin^2(\phi - \frac{1}{6}\pi) \, d\phi \right\} \right]^{1/2}$$

$$V_{rms} = I_{rms} R = V \left[\frac{5}{4} - \frac{3}{2\pi} \alpha + \frac{3}{8\pi} \sin 2\alpha + \frac{3\sqrt{3}}{8\pi} \cos 2\alpha \right]^{1/2} = V \left[\frac{5}{4} - \frac{3}{2\pi} \alpha + \frac{3}{4\pi} \sin(2\alpha + \frac{1}{3}\pi) \right]^{1/2} \quad (15.75)$$

The Fourier co-efficients of the fundamental frequency are

$$a_1 = -\frac{3}{4\pi} V (1 + \cos 2(\alpha - \frac{1}{3}\pi)) \quad b_1 = \frac{3}{4\pi} V (\frac{5}{3}\pi - 2\alpha - \sin 2(\alpha - \frac{1}{3}\pi)) \quad (15.76)$$

Using the same two integration terms, not squared, gives the average half-wave (half-cycle) load voltage, hence specifies the average thyristor current with a resistive load. That is

$$\bar{V}_o^{-1/2\text{cycle}} = 2 \times \bar{I}_T R = \frac{\sqrt{3} \sqrt{2} V}{\pi} (1 + \cos(\alpha + \frac{\pi}{6})) \quad (15.77)$$

iv. $\frac{5}{2}\pi \leq \alpha \leq \pi$ [mode 0] – no conducting thyristors

The interphase voltage falls to zero at $\alpha = \frac{5}{2}\pi$, hence for $\alpha \geq \frac{5}{2}\pi$ the output becomes zero.

In each case the phase current and line to line voltage are related by $V_{Lrms} = \sqrt{3} I_{rms} R$ and the peak voltage is $\hat{V} = \sqrt{2} V_L = \sqrt{6} V$. For a resistive load, load power $3I_{rms}^2 R$ for all load types, and $V_{rms} = I_{rms} R$. Both the line input and load current harmonics occur at $6n \pm 1$ times the fundamental.

b. Inductive-resistive load

Once inductance is incorporated into the load, current can only flow if the phase angle is at least equal to the load phase angle, given by $\phi = \tan^{-1} \omega L / R$. Due to the possibility of continuation of the load current because of the stored inductive load energy, only two thyristor operational modes occur. The initial mode at $\phi \leq \alpha$ operates with three then two conducting thyristors mode [3/2], then as the control angle increases, operation in a mode [2/0] occurs with either two devices conducting or all three off, until $\alpha = \frac{5}{2}\pi$. The transitions between 3 and 2 thyristors conducting and between the two modes involves solutions to transcendental equations, and the rms output voltage, whence currents, depend on the solution to these equations.

c. Purely inductive load

For a purely inductive load the natural ac power factor angle is $\frac{1}{2}\pi$, where the current lags the voltage by $\frac{1}{2}\pi$. Therefore control for such a load starts from $\alpha = \frac{1}{2}\pi$, and since the average inductor voltage must be zero, conduction is symmetrical about π and ceases at $2\pi - \alpha$. The conduction period is $2(\pi - \alpha)$. Two distinct conduction periods exist.

i. $\frac{1}{2}\pi \leq \alpha \leq \frac{3}{2}\pi$ [mode 3/2] – either 2 or 3 conducting thyristors

Either two or three phases conduct and five integration terms give the load half cycle average voltage, whence average thyristor current, as

$$\bar{V}_o^{-1/2\text{cycle}} = \frac{2\sqrt{2} V}{\pi} (2 \cos \alpha - \sqrt{3} \sin \alpha + 1 + \sqrt{3}) \quad (15.78)$$

The thyristor maximum average current is when $\alpha = \frac{1}{2}\pi$.

When only two thyristors conduct, the phase current during the conduction period is given by

$$i(\omega t) = \frac{\sqrt{2} V}{\omega L} \left(\frac{3}{2} \cos \alpha - \frac{\sqrt{3}}{2} \cos \left(\omega t + \frac{\pi}{6} \right) \right) \quad (15.79)$$

The load phase rms voltage and current are

$$V_{rms} = V \left(\frac{5}{2} - \frac{3}{\pi} \alpha + \frac{3}{2\pi} \sin 2\alpha \right)^{1/2}$$

$$I_{rms} = \frac{V}{\omega L} \left(\frac{5}{2} - \frac{3}{\pi} \alpha + \left(7 - \frac{6}{\pi} \alpha \right) \cos^2 \alpha + \frac{9}{2\pi} \sin 2\alpha \right)^{1/2} \quad (15.80)$$

The magnitude of the sin term fundamental ($a_1 = 0$) is

$$V_1 = b_1 = \frac{3}{2\pi} V \left(\frac{5}{3}\pi - 2\alpha + \sin 2\alpha \right) = I_1 \omega L \quad (15.81)$$

while the remaining harmonics ($a_h = 0$) are given by

$$V_h = b_h = \frac{3}{\pi} V \left(\frac{\sin(h+1)\alpha}{h+1} + \frac{\sin(h-1)\alpha}{h-1} \right) \quad (15.82)$$

ii. $\frac{3}{2}\pi \leq \alpha \leq \frac{5}{2}\pi$ [mode 2/0] – either 2 or no conducting thyristors

Discontinuous current flows in two phases, in two periods per half cycle and two integration terms (reduced to one after time shifting) give the load half cycle average voltage, whence average thyristor current, as

$$\bar{V}_o^{-1/2\text{cycle}} = \frac{2\sqrt{2} V}{\pi} \sqrt{3} (1 + \cos(\alpha + \frac{\pi}{6})) \quad (15.83)$$

which reduces to zero volts at $\alpha = \frac{5}{2}\pi$.

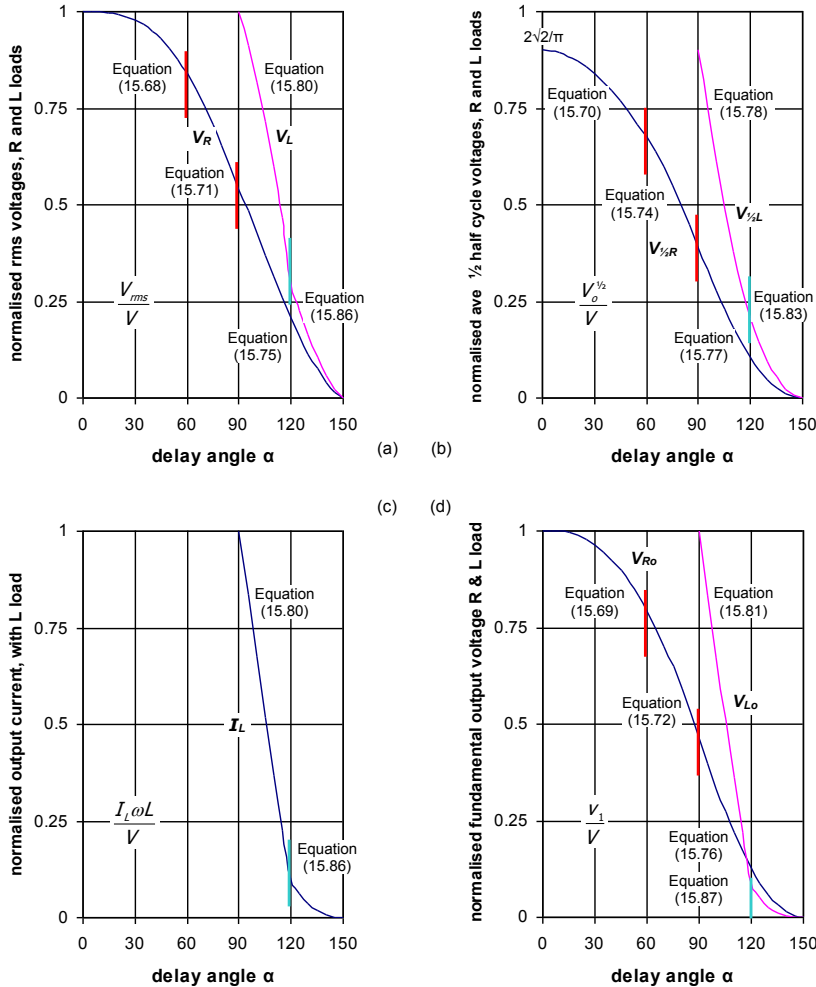

Figure 15.20. Three-phase ac full-wave voltage controller characteristics for purely resistive and inductive loads: (a) normalised rms output voltages; (b) normalised half-cycle average voltages; (c) normalised output current for a purely inductive load; and (d) fundamental ac output voltage.

The average thyristor current is given by

$$\begin{aligned} \bar{I}_T &= 2 \times \frac{1}{2\pi} \int_{\alpha}^{\frac{3}{2}\pi-\alpha} \frac{\sqrt{3}\sqrt{2}V}{2\omega L} \left[\cos\left(\alpha + \frac{\pi}{6}\right) - \cos\left(\omega t + \frac{\pi}{6}\right) \right] d\omega t \\ &= \frac{\sqrt{3}\sqrt{2}V}{2\pi\omega L} \left[\left(\frac{5}{3}\pi - 2\alpha\right) \cos\left(\alpha + \frac{\pi}{6}\right) - 2\sin\left(\alpha + \frac{\pi}{6}\right) \right] \end{aligned} \quad (15.84)$$

When two thyristors conduct, the phase current during the conduction period is given by

$$i(\omega t) = \frac{\sqrt{2}V}{\omega L} \frac{\sqrt{3}}{2} \left(\cos\left(\alpha + \frac{\pi}{6}\right) - \cos\left(\omega t + \frac{\pi}{6}\right) \right) \quad (15.85)$$

The load phase rms voltage and current are

$$\begin{aligned} V_{rms} &= V \left(\frac{5}{2} - \frac{3}{\pi} \alpha + \frac{3}{2\pi} \sin(2\alpha + \frac{1}{3}\pi) \right)^{1/2} \\ I_{rms} &= \frac{V}{\omega L} \left[\frac{5}{2} - \frac{3\alpha}{\pi} + \left(5 - \frac{6\alpha}{\pi} \right) \cos^2\left(\alpha + \frac{1}{6}\pi\right) + \frac{9}{2\pi} \sin\left(2\alpha + \frac{1}{6}\pi\right) \right]^{1/2} \end{aligned} \quad (15.86)$$

The magnitude of the sin term fundamental ($a_h = 0$) is

$$V_1 = b_1 = \frac{3}{2\pi} V \left(\frac{5}{3}\pi - 2\alpha - \sin 2\left(\alpha - \frac{1}{3}\pi\right) \right) = I_1 \omega L \quad (15.87)$$

while the remaining harmonics ($a_h = 0$) are given by

$$V_h = b_h = \pm \frac{3}{\pi} V \left(\frac{\sin(h \pm 1)\alpha}{h \pm 1} + \frac{\sin(h \mp 1)(\alpha - \frac{1}{3}\pi)}{h \mp 1} \right) \quad \text{for } h = 6k \mp 1 \quad (15.88)$$

Various normalised voltage and current characteristics for resistive and inductive equations derived are shown in figure 15.20.

15.4.2 Fully-controlled three-phase ac regulator with wye load and neutral connected

If the load and supply neutrals are connected in the three-phase thyristor controller with a wye load as shown in figure 15.21 and dashed in figure 15.19a, then (possibly undesirably) neutral current can flow and each of the three loads can be controlled independently. Undesirably, the third harmonic and its odd multiples are algebraically summed and returned to the supply via the neutral connection. At any instant $i_N = i_a + i_b + i_c$.

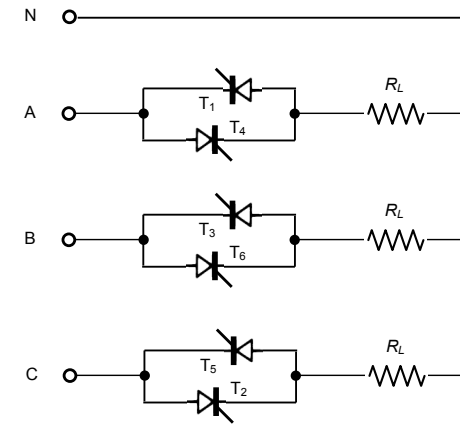

Figure 15.21. Three-phase ac full-wave 4-wire star-load ac controller.

For a resistive balanced load there are three modes of thyristor conduction.

When 3 thyristors conduct $i_a + i_b + i_c = I_N = 0$, two thyristors conduct $I_N = -\sqrt{2}V/R \sin(\omega t - \frac{2}{3}\pi)$, and for one thyristor $I_N = I_T = \sqrt{2}V/R \sin\omega t$.

Mode [3/2] $0 \leq \alpha \leq \frac{1}{3}\pi$

Periods of zero neutral current occur when three thyristors conduct and the rms of the discontinuous neutral current is given by

$$\begin{aligned} I_N^2 &= \frac{3}{\pi} \int_{\frac{1}{3}\pi}^{\alpha+\frac{1}{3}\pi} \left(-\sqrt{2}V/R \sin\left(\omega t - \frac{2}{3}\pi\right) \right)^2 dt \\ I_N &= \frac{V}{R} \times \left[\frac{3}{\pi} \left(\alpha - \frac{1}{2}\sin 2\alpha \right) \right]^{1/2} \end{aligned} \quad (15.89)$$

The average neutral current is

$$\bar{I}_N = \frac{3\sqrt{2}V}{\pi R} (1 - \cos \alpha) \quad (15.90)$$

At $\alpha = 0^\circ$, no neutral current flows since the load is seen as a balance load supplied by the three-phase ac supply, without an interposing controller.

Mode [2/1] $\frac{1}{3}\pi \leq \alpha \leq \frac{2}{3}\pi$

From α to $\frac{2}{3}\pi$ two phase conduct and after $\frac{2}{3}\pi$ the neutral current is due to one thyristor conducting. The rms neutral current is given by

$$I_N^2 = \frac{3}{\pi} \int_{\alpha}^{\frac{2}{3}\pi} \left(-\sqrt{2}V/R \sin(\omega t - \frac{4}{3}\pi) \right)^2 dt + \frac{3}{\pi} \int_{\frac{2}{3}\pi}^{\frac{\alpha+\pi}{2}} \left(\sqrt{2}V/R \sin \omega t \right)^2 dt$$

$$I_N = \frac{V}{R} \times \left[1 - \frac{3\sqrt{3}}{\pi} \cos^2 \alpha \right]^{1/2} \quad (15.91)$$

Maximum rms neutral current occurs at $\alpha = \frac{1}{2}\pi$, when $I_N = V/R$.

The average neutral current is

$$\bar{I}_N = \frac{3\sqrt{2}V}{\pi R} (\sqrt{3} \sin \alpha - 1) \quad (15.92)$$

The maximum average neutral current, at $\alpha = \frac{1}{2}\pi$, is

$$\hat{\bar{I}}_N = \frac{3\sqrt{2}V}{\pi R} (\sqrt{3} - 1) = 0.9886 \frac{V}{R} \quad (15.93)$$

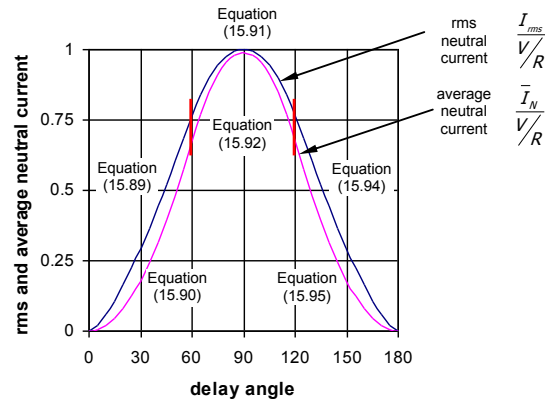

Figure 15.22. Three-phase ac full-wave voltage neutral-connected controller with resistive load, normalised rms neutral current and normalised average neutral current.

Mode [1/0] $\frac{2}{3}\pi \leq \alpha \leq \pi$

The neutral current is due to only one thyristor conducting. The rms neutral current is given by

$$I_N^2 = \frac{3}{\pi} \int_{\alpha}^{\pi} \left(\sqrt{2}V/R \sin \omega t \right)^2 dt$$

$$I_N = \frac{V}{R} \times \left[\frac{3}{\pi} (\pi - \alpha + \frac{1}{2} \sin 2\alpha) \right]^{1/2} \quad (15.94)$$

The average neutral current is

$$\bar{I}_N = \frac{3\sqrt{2}V}{\pi R} (1 + \cos \alpha) \quad (15.95)$$

The neutral current is greater than the line current until the phase delay angle $\alpha > 67^\circ$. The neutral current reduces to zero when $\alpha = \pi$, since no thyristors conduct.

The normalised neutral current characteristics are shown plotted in figure 15.22.

15.4.3 Fully-controlled three-phase ac regulator with delta load

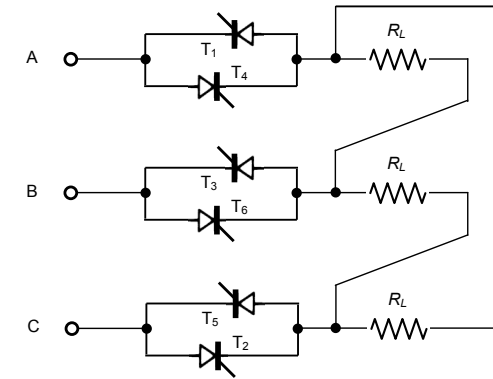

Figure 15.23. Three-phase ac full-wave 3-wire delta-load ac controller.

The load in figure 15.19a can be replaced with the delta in figure 15.19c (see section 15.4.3, figure 15.23). Star and delta load equivalence applies in terms of the same line voltage, line current, and thyristor voltages, provided the load is linear. A delta connected load can be considered to be three independent single phase ac regulators, where the total power (for a balanced load) is three times that of one regulator, that is

$$Power = 3 \times VI_1 \cos \phi_1 = \sqrt{3} VI_{L1} \cos \phi_1 \quad (15.96)$$

i. In load delta connection

For delta-connected loads where each phase end is accessible, the regulator shown in figure 15.24 can be employed in order to reduce thyristor current ratings. Each phase forms a separate single-phase ac controller as considered in section 15.1 but the phase voltage is the line-to-line voltage, $\sqrt{3}V$.

For a resistive load, the phase rms voltage, hence current, given by equations (15.23) and (15.24) are increased by $\sqrt{3}$, viz.:

$$V_{rms} = \left[\frac{1}{2\pi} \int_{\alpha}^{\pi} (\sqrt{2}V \sin \omega t)^2 dt \right]^{1/2}$$

$$V_{rms} = \sqrt{3} V \left[1 - \frac{\alpha}{\pi} + \frac{\sin 2\alpha}{2\pi} \right]^{1/2} = \sqrt{3} I_{rms} R \quad 0 \leq \alpha \leq \pi \quad (15.97)$$

The line current is related to the sum of two phase currents, each phase shifted by 120° . For a resistive delta load, three modes of phase angle dependent modes of operation can occur.

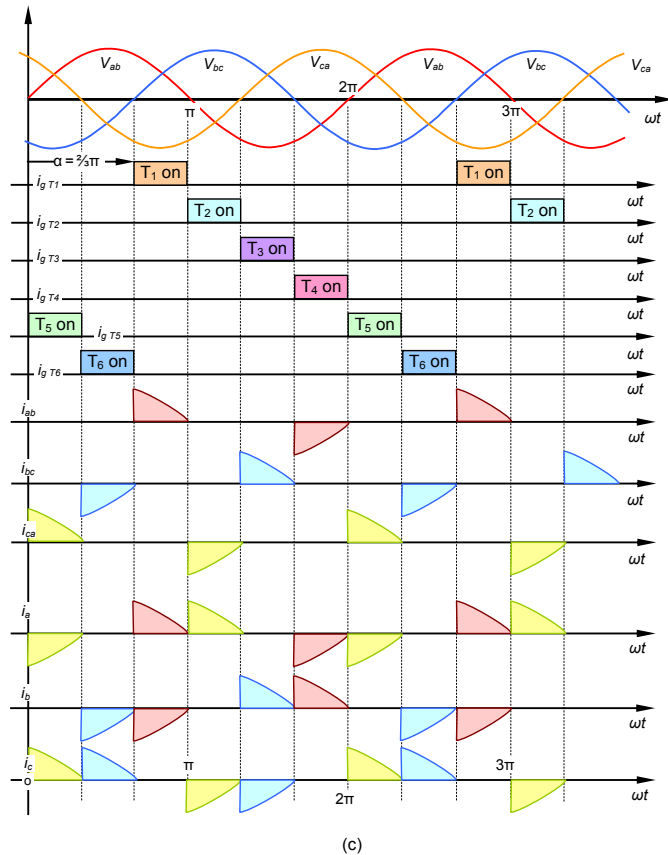
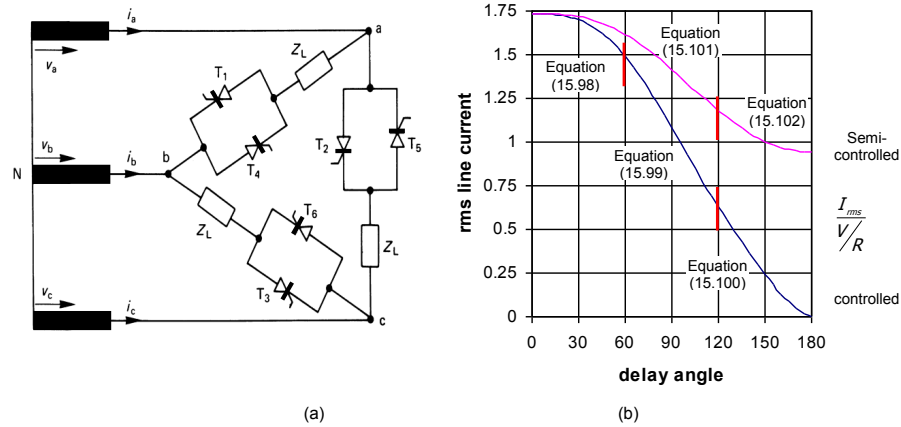

Figure 15.24. An in-delta connected three-phase ac regulator: (a) circuit configuration; (b) normalised line rms current for controlled and semi-controlled resistive loads; and (c) waveforms for an in-circuit resistive load with a 120° delay angle.

Mode [3/2] $0 \leq \alpha \leq \frac{1}{2}\pi$

The line current is given by

$$I_L = \frac{\sqrt{3}}{R} V \left[1 - \frac{4}{3\pi} \alpha + \frac{2}{3\pi} \sin 2\alpha \right]^{1/2} \quad (15.98)$$

Mode [2/1] $\frac{1}{2}\pi \leq \alpha \leq \frac{2}{3}\pi$

The line current is given by

$$I_L = \frac{\sqrt{3}}{R} V \left[\frac{8}{9} - \frac{1}{\pi} \alpha + \frac{\sqrt{3}}{6\pi} (1 + \sqrt{3} \sin 2\alpha + \cos 2\alpha) \right]^{1/2} \quad (15.99)$$

$$= \frac{\sqrt{3}}{R} V \left[\frac{8}{9} - \frac{1}{\pi} \alpha + \frac{\sqrt{3}}{6\pi} (1 + 2 \sin(2\alpha + \frac{1}{6}\pi)) \right]^{1/2}$$

Mode [1/0] $\frac{2}{3}\pi \leq \alpha \leq \pi$

The line current is given by

$$I_L = \frac{\sqrt{3}}{R} V \left[\frac{2}{3} - \frac{2}{3\pi} \alpha + \frac{1}{3\pi} \sin 2\alpha \right] \quad (15.100)$$

The thyristors must be retriggered to ensure the current picks up after α .

Half-controlled

When the delta thyristor arrangement in figure 15.24 is half controlled (T_2, T_4, T_6 replaced by diodes) there are two mode of thyristor operation, with a resistive load.

Mode [3/2] $0 \leq \alpha \leq \frac{2}{3}\pi$

The line current is given by

$$I_L = \frac{\sqrt{3}}{R} V \left[1 - \frac{2}{3\pi} \alpha + \frac{1}{3\pi} \sin 2\alpha \right]^{1/2} \quad (15.101)$$

Mode [2/1] $\frac{2}{3}\pi \leq \alpha \leq \pi$

The line current is given by

$$I_L = \frac{\sqrt{3}}{R} V \left[\frac{8}{9} - \frac{1}{2\pi} \alpha - \frac{\sqrt{3}}{12\pi} (1 - 2 \sin(2\alpha - \frac{1}{6}\pi)) \right]^{1/2} \quad (15.102)$$

15.4.4 Half-controlled three-phase ac regulator

The half-controlled three-phase regulator shown in figure 15.25a requires only a single trigger pulse per thyristor and the return path is via a diode. Compared with the fully controlled regulator, the half-controlled regulator is simpler and does not give rise to dc components but does produce more line harmonics.

Figure 15.25b shows resistive symmetrical load, line-to-neutral voltage waveforms for four different phase delay angles, α .

a. Resistive load

Three distinctive conduction periods exist.

i. $0 \leq \alpha \leq \frac{1}{2}\pi$ – [mode3/2]

Before turn-on, one diode and one thyristor conduct in the other two phases. After turn-on two thyristors and one diode conduct, and the three-phase ac supply is impressed across the load. The output phase voltage is asymmetrical about zero volts, but with an average voltage of zero. Examination of the $\alpha = \frac{1}{4}\pi$ waveform in figure 15.25b shows the voltage waveform is made from three segments. The rms load voltage per phase (line to neutral) is

$$V_{rms} = I_{rms} R = V \left[1 - \frac{3}{4\pi} \alpha + \frac{3}{8\pi} \sin 2\alpha \right]^{1/2} \quad 0 \leq \alpha \leq \frac{1}{2}\pi \quad (15.103)$$

The Fourier co-efficients for the fundamental voltage, for a resistive load are

$$a_1 = \frac{3}{8\pi} V (\cos 2\alpha - 1) \quad b_1 = \frac{3}{8\pi} V \left(\frac{8\pi}{3} - 2\alpha + \sin \alpha \right) \quad (15.104)$$

Using three integration terms, the average half-wave (half-cycle) load voltage, for both halves, specifies the average thyristor and diode current requirement with a resistive load. That is

$$\bar{V}_o^{1/2\text{cycle}} = 2 \times \bar{I}_T R = 2 \times \bar{I}_{Diode} R = \frac{\sqrt{2} V}{2\pi} (3 + \cos \alpha) \quad 0 < \alpha < \frac{1}{3}\pi \quad (15.105)$$

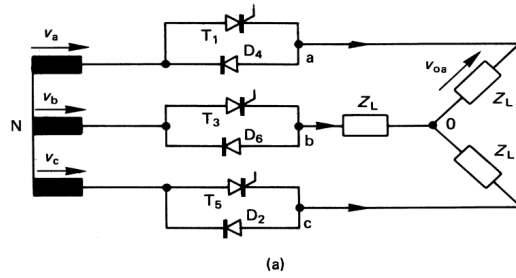

(a)

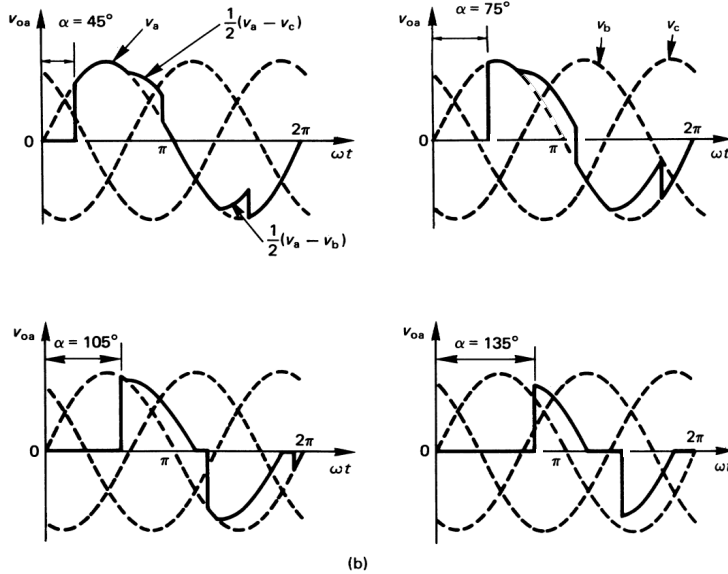

Figure 15.25. Three-phase half-wave ac voltage regulator: (a) circuit connection with a star load and (b) phase a, line-to-load neutral voltage waveforms for four firing delay angles.

The diode and thyristor maximum average current is when $\alpha = 0$, that is $\bar{I}_T = \bar{I}_{Diode} = \frac{\sqrt{2}V}{\pi R}$.

After $\alpha = \frac{1}{3}\pi$, only one thyristor conducts at one instant and the return current is a diode. Examination of the $\alpha = \frac{2}{3}\pi$ and $\alpha = \frac{5}{6}\pi$ waveforms in figure 15.25b show the voltage waveform is made from three segments, although different segments of the supply around $\omega t = \pi$. Using three integration terms, the average half-wave (half-cycle) load voltage, for both halves, specifies the average thyristor and diode current requirement with a resistive load. That is

$$\bar{V}_o^{-1/2\text{cycle}} = 2 \times \bar{I}_T R = 2 \times \bar{I}_{Diode} R = \frac{\sqrt{2}V}{2\pi} (1 + 2 \cos \alpha + \sqrt{3} \sin \alpha) \quad \alpha > \frac{1}{3}\pi \quad (15.106)$$

ii. $\frac{1}{2}\pi \leq \alpha \leq \frac{2}{3}\pi$ – [mode3/2/0]

Only one thyristor conducts at one instant and the return current is shared at different intervals by one ($\frac{1}{3}\pi \leq \alpha \leq \frac{1}{2}\pi$) or two ($\frac{1}{2}\pi \leq \alpha \leq \frac{2}{3}\pi$) diodes. Examination of the $\alpha = \frac{2}{3}\pi$ and $\alpha = \frac{5}{6}\pi$ waveforms in figure 15.25b show the voltage waveform comprises two segments, although different segments of the supply around $\omega t = \pi$. The rms load voltage per phase (line to neutral) is

$$V_{rms} = I_{rms} R = V \left[\left\{ \frac{11}{8} - \frac{3}{2\pi} \alpha \right\} \right]^{1/2} \quad \frac{1}{2}\pi \leq \alpha \leq \frac{2}{3}\pi \quad (15.107)$$

The resistive load fundamental is

$$a_1 = -\frac{3}{4\pi} V \quad b_1 = \frac{3}{4\pi} V \left(\frac{1}{6}\pi - 2\alpha \right) \rightarrow V_1 = \frac{3}{4\pi} V \sqrt{1 + \left(\frac{1}{6}\pi - 2\alpha \right)^2} = I_1 R \quad (15.108)$$

Using two integration terms, the average half-wave (half-cycle) load voltage, for both halves, specifies the average thyristor and diode current requirement with a resistive load. That is

$$\bar{V}_o^{-1/2\text{cycle}} = 2 \times \bar{I}_T R = 2 \times \bar{I}_{Diode} R = \frac{\sqrt{2}V}{2\pi} (1 + \sqrt{3} + 2 \cos \alpha) \quad (15.109)$$

iii. $\frac{2}{3}\pi \leq \alpha \leq 7\pi/6$ – [mode2/0]

Current flows in only one thyristor and one diode and at $7\pi/6$ zero power is delivered to the load. The output is symmetrical about zero. The output voltage waveform shown for $\alpha = \frac{3}{4}\pi$ in figure 15.25b has one component.

$$V_{rms} = I_{rms} R = V \left[\frac{7}{8} - \frac{3}{4\pi} \alpha + \frac{3}{16\pi} \sin 2\alpha - \frac{3\sqrt{3}}{16\pi} \cos 2\alpha \right]^{1/2} = V \left[\frac{7}{8} - \frac{3}{4\pi} \alpha + \frac{3}{8\pi} \sin(2\alpha - \frac{1}{2}\pi) \right]^{1/2} \quad (15.110)$$

$$\frac{2}{3}\pi \leq \alpha \leq \frac{7}{6}\pi$$

with a fundamental given by

$$a_1 = -\frac{3}{4\pi} V \cos^2(\alpha - \frac{2}{3}\pi) \quad b_1 = \frac{3}{4\pi} V \left[\frac{7}{6}\pi - \alpha - \frac{1}{2} \sin 2(\alpha - \frac{2}{3}\pi) \right] \quad (15.111)$$

Using one integration term, the average half-wave (half-cycle) load voltage, for both halves, specifies the average thyristor and diode current requirement with a resistive load. That is

$$\bar{V}_o^{-1/2\text{cycle}} = 2 \times \bar{I}_T R = 2 \times \bar{I}_{Diode} R = \frac{\sqrt{2}V}{2\pi} \sqrt{3} (1 + \cos(\alpha - \frac{\pi}{6})) \quad (15.112)$$

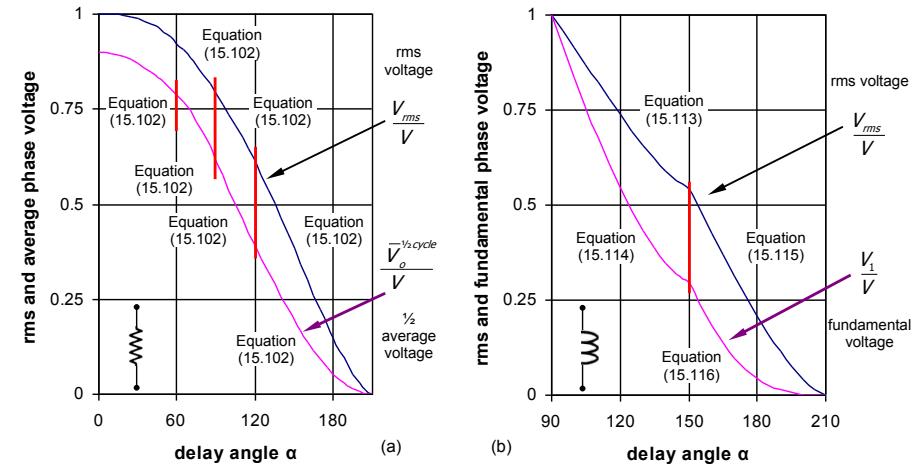

Figure 15.26. Three-phase half-wave ac voltage regulator characteristics: (a) rms phase and average half cycle voltages for a resistive load and (b) rms and fundamental voltages for an inductive load.

b. Purely inductive load

Two distinctive conduction periods exist.

i. $\frac{1}{2}\pi \leq \alpha \leq \frac{5}{6}\pi$ – [mode3/2]

For a purely inductive load (cycle starts at $\alpha = \frac{1}{2}\pi$)

$$V_{rms} = I_{rms} \omega L = V \sqrt{\frac{1}{4} - \frac{3}{2\pi} \alpha + \frac{3}{4\pi} \sin 2\alpha} \quad \frac{1}{2}\pi \leq \alpha \leq \frac{5}{6}\pi \quad (15.113)$$

while for a purely inductive load the fundamental voltage is ($a_1 = 0$)

$$b_1 = V_1 = \frac{3}{4\pi} V \left(\frac{2\pi}{3} - 2\alpha + \sin 2\alpha \right) = I_1 \omega L \quad (15.114)$$

ii. $\frac{5}{6}\pi \leq \alpha \leq \frac{7}{6}\pi - [\text{mode2/0}]$

For a purely inductive load, no mode 3/2/0 exist and rms load voltage for mode2/0 is

$$V_{rms} = I_{rms}\omega L = V\sqrt{\left(\frac{7}{4} - \frac{3}{2\pi}\alpha + \frac{3}{4\pi}\sin(2\alpha - \frac{\pi}{3})\right)} \quad (15.115)$$

with a fundamental given by ($a_1 = 0$)

$$b_1 = V_1 = \frac{3}{4\pi}V\left[\frac{7\pi}{3} - 2\alpha - \sin 2\left(\alpha - \frac{2\pi}{3}\right)\right] = I_1\omega L \quad (15.116)$$

When $\alpha > \pi$, the load current is dominated by harmonic currents.

Normalised semi-controlled inductive and resistive load characteristics are shown in figure 15.26.

15.4.5 Other thyristor three-phase ac regulators

i. Delta connected fully controlled regulator

For star-connected loads where access exists to a neutral that can be opened, the regulator in figure 15.27a can be used. This circuit produces identical load waveforms to those for the regulator in figure 15.19 regardless of the type of load, except that mean device current ratings are halved (but the line currents are the same). Only one thyristor needs to be conducting for load current, compared with the circuit of figure 15.19 where two devices must be triggered. The triggering control is simplified but the maximum thyristor blocking voltage is increased by $2/\sqrt{3}$, from $3V/\sqrt{2}$ to $\sqrt{6}V$.

Three output voltage modes can be shown to occur, depending of the delay control angle.

- Mode [2/1] $0 \leq \alpha \leq \frac{1}{3}\pi$
- Mode [1] $\frac{1}{3}\pi \leq \alpha \leq \frac{1}{2}\pi$
- Mode [1/0] $\frac{1}{2}\pi \leq \alpha \leq \frac{2}{3}\pi$

In figure 15.27a, at $\alpha = 0$, each thyristor conducts for $\frac{2}{3}\pi$, which for a resistive line load, results in a maximum thyristor average current rating of

$$\bar{I}_T = \frac{3}{2\pi} \frac{\sqrt{2}V_{L-L}}{R} = \frac{3}{2\pi} \frac{\sqrt{3}\sqrt{2}V}{R} \quad (15.117)$$

A half-controlled version is not viable.

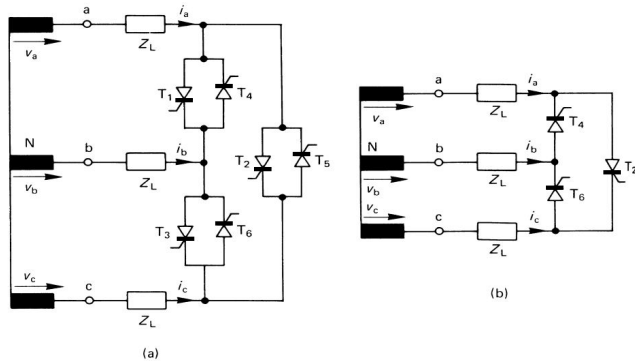

Figure 15.27. Open-star three-phase ac regulators: (a) with six thyristors and (b) with three thyristors.

ii. Three-thyristor delta connected regulator

The number of devices and control requirements for the regulator of figure 15.27a can be simplified by employing the regulator in figure 15.27b. In figure 15.27b, because of the half-wave configuration, at $\alpha = -\frac{1}{3}\pi$, each thyristor conducts for $\frac{2}{3}\pi$, which for a resistive line load, results in a maximum thyristor average current rating of

$$\bar{I}_T = \frac{3}{2\pi} \frac{\sqrt{2}V_{L-L}}{\sqrt{3}R} = \frac{3\sqrt{2}V}{2\pi R} \quad (15.118)$$

Two thyristors conduct at any time as shown by the six sequential conduction possibilities that complete one mains ac cycle in figure 15.28.

Three output voltage modes can be shown to occur, depending of the delay control angle.

- Mode [2/1] $-\frac{1}{3}\pi \leq \alpha \leq \frac{1}{6}\pi$
- Mode [2/1/0] $\frac{1}{6}\pi \leq \alpha \leq \frac{1}{3}\pi$
- Mode [1/0] $\frac{1}{3}\pi \leq \alpha \leq \frac{2}{3}\pi$

The control angle reference has been moved to the phase voltage crossover, the first instant the device becomes forward biased, hence able to conduct. This is $\frac{1}{3}\pi$ earlier than conventional three-phase fully controlled type circuits.

Another simplification, at the expense of harmonics, is to connect one phase of the load in figure 15.19a directly to the supply, thereby eliminating a pair of line thyristors.

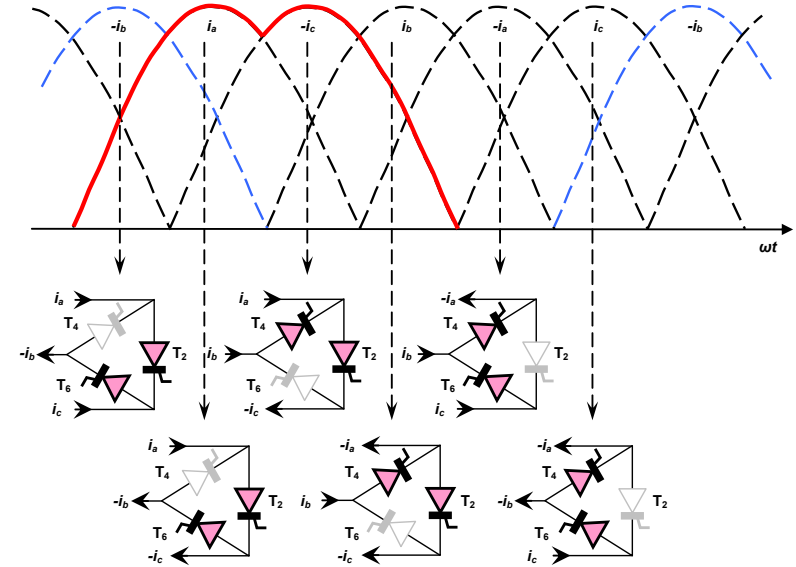

Figure 15.28. Open-star three-phase ac regulators with three thyristors (figure 15.27b): (a) thyristors currents and (b) six line current possibilities during consecutive 60° segments.

Table 15.1: Thyristor electrical ratings for four ac controllers

Circuit figure	Max input line rms current, I_{ac}	Max load power	Thyristor				Control delay angle range	
			Voltage $\times \sqrt{2}V$	rms current $/ I_{ac}$	Peak current $/ I_{ac}$	Mean current $/ I_{ac}$	Resistive load	Inductive load
15.19	$V/\sqrt{3}Z$	$3I_{ac}^2R$	$\sqrt{3}/2$	$1/\sqrt{2}$	$\sqrt{2}$	$\sqrt{2}/\pi$	$0 \leq \alpha \leq \frac{5}{6}\pi$	$\frac{1}{2}\pi \leq \alpha \leq \frac{5}{6}\pi$
15.21	$V/\sqrt{3}Z$	$3I_{ac}^2R$	$\sqrt{2}/3$	$1/\sqrt{2}$	$\sqrt{2}$	$\sqrt{2}/\pi$	$0 \leq \alpha \leq \pi$	
15.23	$\sqrt{3}V/Z$	I_{ac}^2R	$\sqrt{3}/2$	$1/\sqrt{2}$	$\sqrt{2}$	$\sqrt{2}/\pi$	$0 \leq \alpha \leq \pi$	
15.24	$\sqrt{3}V/Z$	I_{ac}^2R	$\sqrt{2}$	$\frac{1}{2}\sqrt{2}/3$	$\sqrt{2}/3$	$\sqrt{2}/\pi \cdot \sqrt{3}$	$0 \leq \alpha \leq \pi$	$\frac{1}{2}\pi \leq \alpha \leq \pi$
15.25	$V/\sqrt{3}Z$	$3I_{ac}^2R$	$\sqrt{3}/2$	$1/\sqrt{2}$	$\sqrt{2}$	$\sqrt{2}/\pi$	$0 \leq \alpha \leq \frac{5}{6}\pi$	$\frac{1}{2}\pi \leq \alpha \leq \frac{5}{6}\pi$
15.27a	$V/\sqrt{3}Z$	$3I_{ac}^2R$	$\sqrt{2}$	$\frac{1}{2}\sqrt{2}/3$	$\sqrt{2}/3$	$\sqrt{2}/\pi \cdot \sqrt{3}$	$0 \leq \alpha \leq \frac{5}{6}\pi$	
15.27b			$\sqrt{2}$	0.766			$-\frac{1}{3}\pi \leq \alpha \leq \frac{5}{6}\pi$	$\frac{1}{2}\pi \leq \alpha \leq \frac{5}{6}\pi$

Example 15.6: Star-load three-phase ac regulator – untapped neutral

A 230V (line to neutral) 50Hz three-phase mains ac thyristor chopper has a symmetrical star load composed of 10Ω resistances. If the thyristor triggering delay angle is $\alpha = 90^\circ$ determine

- The rms load current and voltage, and maximum rms load current for any phase delay angle
- The power dissipated in the load
- The thyristor average and rms current ratings and voltage ratings
- Power dissipated in the thyristors when modelled by $v_T = v_o + r_o \times i_T = 1.2 + 0.01 \times i_T$

Repeat the calculations if each phase load is a 20mH.

Solution**(a) 10Ω Resistive load - $\alpha = 90^\circ$**

- rms voltage from equation (15.71)

$$V_{rms} = I_{rms} R = V \left[\frac{1}{2} + \frac{3\sqrt{3}}{4\pi} \cos(2\alpha + \frac{\pi}{6}) \right]^{1/2}$$

$$= 230V \left[\frac{1}{2} + \frac{3\sqrt{3}}{4\pi} \cos(2 \times 90^\circ + 30^\circ) \right]^{1/2} = 230V \times 0.377 = 86.6V$$

whence the rms current

$$I_{rms} = \frac{V_{rms}}{R} = \frac{86.6V}{10\Omega} = 8.66A$$

- The load power is

$$P_{10\Omega} = I_{rms}^2 R = 8.66^2 \times 10\Omega = 750.7W$$

- Thyristor average current from equation (15.74)

$$\bar{I}_T = \frac{\sqrt{3}\sqrt{2}V}{2\pi R} (\sin \alpha - \frac{1}{2})$$

$$= \frac{\sqrt{3}\sqrt{2} \times 230V}{2\pi \times 10\Omega} (\sin 1/2\pi - 1/2) = 4.48A$$

Thyristor rms current

$$I_{T,rms} = \frac{I_{rms}}{\sqrt{2}} = \frac{8.66A}{\sqrt{2}} = 6.12A$$

- Thyristor loss

$$P_T = v_o \bar{I}_T + r_o \bar{I}_T^2 = 1.2 \times \bar{I}_T + 0.01 \times \bar{I}_T^2$$

$$= 1.2 \times 4.48A + 0.01 \times 6.12^2 = 5.75W$$

(b) 20mH Inductive load - $\alpha = 90^\circ$

- rms voltage and current from equation (15.80)

$$V_{rms} = V \left(\frac{5}{2} - \frac{3}{\pi} \alpha + \frac{3}{2\pi} \sin 2\alpha \right)^{1/2}$$

$$= 230V \left(\frac{5}{2} - \frac{3}{\pi} \times 1/2\pi \right)^{1/2} = 230V$$

$$I_{rms} = \frac{V}{\omega L} \left(\frac{5}{2} - \frac{3}{\pi} \alpha + \left(7 - \frac{6}{\pi} \alpha \right) \cos^2 \alpha + \frac{9}{2\pi} \sin 2\alpha \right)^{1/2}$$

$$= \frac{230V}{2\pi \times 50Hz \times 0.02H} \left(\frac{5}{2} - \frac{3}{\pi} \times 1/2\pi \right)^{1/2} = \frac{230V}{2\pi \times 50Hz \times 0.02H} = 36.6A$$

- The load power is zero.

- Since the delay angle is 90° , the natural power factor angle, continuous sinusoidal current flows and the thyristor average current is

$$\bar{I}_T = \frac{1}{\sqrt{2}} \frac{2\sqrt{2}}{\pi} I_{rms} = \frac{1}{\sqrt{2}} \frac{2\sqrt{2}}{\pi} 36.6A = 23.3A$$

Thyristor rms current

$$I_{T,rms} = \frac{I_{rms}}{\sqrt{2}} = \frac{36.6A}{\sqrt{2}} = 25.88A$$

- Thyristor loss

$$P_T = v_o \bar{I}_T + r_o \bar{I}_T^2 = 1.2 \times \bar{I}_T + 0.01 \times \bar{I}_T^2$$

$$= 1.2 \times 25.88A + 0.01 \times 36.6^2 = 44.45W$$

15.4.6 Solid-state soft starters

An electric motor soft starter is a device used to temporarily reduce the load and torque in the power-train of any electric motor during start-up. This reduces the mechanical stress on the motor and shaft, as well as the electrodynamic stresses on the interconnecting power cables and electrical distribution network, thereby extending system lifetime.

Motor soft starters can consist of mechanical or electrical devices, or a combination of both. Mechanical soft starters include clutches and several types of couplings using a fluid or magnetic forces. Electrical soft starters can be any control system that reduces the torque by temporarily reducing the voltage or current input, or a device that temporarily alters how the motor is connected in the electric supply circuit. In the case of the three-phase induction motor, electrical soft starters can utilize solid-state devices to control the current flow and therefore the voltage applied to the motor. The starter can be connected in series with the line voltage applied to the motor, or can be connected inside the delta loop of a delta-connected motor, thus is able to control the voltage applied to each winding. Solid-state soft starters can control one or more phases of the voltage applied to the induction motor with the best results achieved by three-phase control. Typically, the voltage is controlled via inverse-parallel-connected silicon-controlled rectifiers (SCR), but in some circumstances with three-phase control, the control elements can be a inverse-parallel-connected SCR and diode combination.

A solid-state soft starter is basically a three-phase ac to ac fully controlled regulating converter as shown in figure 15.19, used to soft-start three-phase ac caged (asynchronous) induction motors. A soft-starter is functionally two/three ac instantaneous controlled solid-state relays, as in section 15.1.3, with the two/three isolated dc control inputs connected together.

15.4.6i The induction motor

The induction motor is the simplest and most rugged of all electric motors. It consists of two basic electrical assemblies: the wound stator and the cage rotor assembly.

Three-phase voltage supplies the stator windings which produce a three-phase rotating magnetic field. The electrically isolated rotor consists of laminated, cylindrical iron cores with slots for receiving the conductors. On early motors, the conductors were copper bars with ends welded to copper rings known as end rings. Viewed from the end, the rotor assembly resembles a squirrel cage, hence the name squirrel-cage motor is used to refer to induction motors. In modern induction motors, the most common type of rotor has cast-aluminium conductors and short-circuiting end rings. The rotor turns when the stator rotating magnetic field induces a current in the rotor shorted conductors. This rotor current produces a rotor magnetic field which interacts with the stator field, producing a rotating torque. The speed at which the stator magnetic field rotates is the synchronous speed of the motor and is determined by the number of poles in the stator and the frequency of the ac power supply voltage.

$$n_s = \frac{60 \times f}{P} \quad (\text{rpm}) \quad (15.119)$$

where n_s = synchronous speed, rpm

f = frequency, Hz

P = number of pole pairs

Synchronous speed is the absolute upper limit of motor speed. At synchronous speed, there is no difference between rotor speed and the rotating field speed, so no voltage is induced in the rotor bars, hence no torque is developed. Therefore, when running, the rotor must rotate slower than the magnetic field. The rotor speed is just slow enough to cause the proper amount of rotor current to flow, so that the resulting torque is sufficient to overcome windage and friction losses, and drive the load. This speed difference between the rotor and stator magnetic field, called slip, is normally referred to as a percentage of synchronous speed:

$$s = \frac{n_s - n_R}{n_s} = 1 - \frac{n_R}{n_s} \leq 1 \quad (15.120)$$

where s = slip

n_R = actual rotor speed, rpm

In order to appreciate the attributes of using an electronic motor controller, it is necessary to have an understanding of the characteristics and limitations of the three-phase ac caged induction (asynchronous) motor and the traditional electromechanical systems used to control it.

The standard, (near) fixed-speed induction motor fulfils two basic mechanical requirements:

- accelerates itself and its mechanically connected rotational load to full speed and
- maintains the load at full speed efficiently and effectively over the full range of loadings.

Due to the constraints of machine materials and design, it is difficult to achieve both mechanical objectives effectively and economically in one machine.

Electromechanical motors convert electrical energy drawn from the ac power supply into a mechanical rotating form, usually as a shaft rotating at a speed related to the number of machine pole pairs, P , and the frequency of the ac supply, f . The mechanical power P_m (W) available from the shaft is equal to the mechanical torque T_m (N) multiplied by the shaft speed, n_R (rad/s), $P_m = T_m \times n_R$. From an initial value at standstill, the torque varies as the machine accelerates, reaching a peak at about 80% full speed, finally reducing to zero at synchronous speed, $n_s = 60f/P$ (rpm). This characteristic means that induction motors always operate at slightly less than synchronous speed, the 'slip speed', $n_{slip} = s \times n_s$ (rpm), in order to develop power, hence the term asynchronous machine. The characteristics in figure 15.29a show an induction motor torque-speed curve, which illustrates the most important mechanical output characteristics.

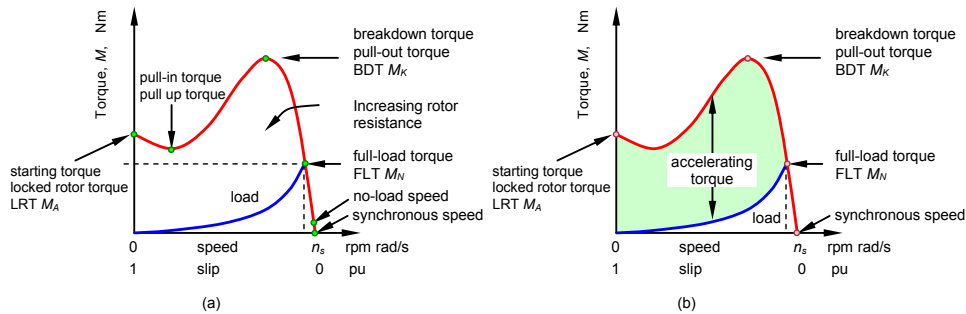

Figure 15.29. Torque-speed curve for the induction motor showing: (a) the coupled load torque requirement and (b) the available accelerating torque.

Any load mechanically coupled to an induction motor has its own particular speed-torque characteristic requirement curve. The acceleration of a motor-load system is due to the difference between the motor developed torque and the load absorbed torque, as shown by the shaded area in figure 15.29b. The larger the torque difference, the higher the acceleration and the quicker full speed is reached, whence the greater the electrical and mechanical stresses experienced by the ac supply and drive system during the acceleration period. An 'ideal' starter accelerates the load with minimal intervention to reach full speed smoothly in a reasonable time, with minimum stress to the supply and drive train.

The motor speed-torque characteristic can be controlled by the rotor cage resistance, where a motor with high rotor resistance can generate its peak torque (pull-out torque) at standstill giving a high break-away torque characteristic, which progressively reduces, as the speed increases, to zero at synchronous speed: NEMA design D in figure 15.30a. A motor with a low rotor resistance will produce a low starting torque but will generate its peak torque closer to the synchronous speed: NEMA designs A and B. Consequently, this type of motor runs at full power with a higher operating efficiency and low slip speed. Induction motors that combine the dual requirements of high starting torque and efficient full-speed operation within a single motor have a double-cage or deep bar design, and this motor characteristic, shown in Figure 15.30a, NEMA design C, is ideal for use with soft starter control. All motors, except class D types, operate at 5% slip or less at full (rated) load.

Notice that all the design classes produce a starting torque and pull-up torque that are greater than the full-load torque level. Full load torque can be developed at any speed, but at the expense of high current, low power factor, and low efficiency, hence increased motor heating. The important difference between the classes is the torque per ampere hence efficiency in the normal operating range, viz., at and above rated speed.

An induction motor with two poles often has a lower starting torque than motors with four or more poles, thus oversized motors may be used to ensure that their mechanical load can be started and driven under all operating conditions.

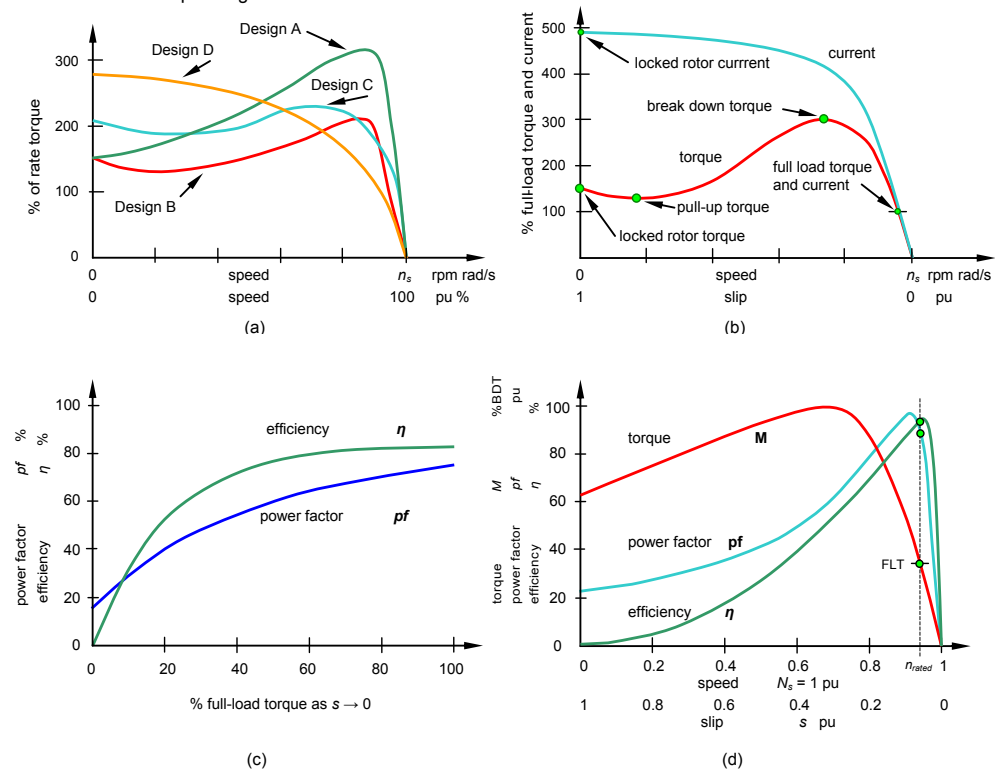

Figure 15.30. Induction motor characteristics: (a) torque-speed curves for various NEMA classes of three-phase ac caged induction motors; (b) speed versus torque and current characteristics; (c) power factor and efficiency versus full-load torque; and (d) torque and efficiency versus rotor speed/slip.

Power factor

Induction motors present a lagging (inductive) power factor to the ac line. The power factor in large fully loaded high-speed motors can be better than 0.90. At $\frac{1}{4}$ full-load, for large high-speed motors the power factor can be 92%. The power factor for small low-speed motors can be as low as 0.5. At starting, the power factor can be in the range of 0.1 to 0.25, improving (increasing) as the rotor gains speed. Power factor (pf) varies considerably with the motor mechanical load as seen in figure 15.30c. An unloaded motor is analogous to a transformer without a secondary load. Little resistance is reflected from the secondary (rotor) to the primary (stator). Thus the ac line sees a reactive load, dominated by the magnetising current, resulting in a pf as low as 0.1 lagging. As the rotor is loaded, an increasing resistive component (representing the developed output power) is reflected from rotor to stator, increasing the power factor.

Efficiency

Large three-phase motors are more efficient than small three-phase motors. Large induction motor efficiency can be as high as 95% at full load, though better than 90% is common. Efficiency for a lightly load or no-load induction motor is poor because most of the current is involved with maintaining the magnetizing flux. As the torque load is increased, more current is consumed in generating torque, while current associated with magnetizing remains fixed. Efficiency at 75% FLT (full load torque) can be slightly higher than that at FLT. Efficiency is decreased a few percent at 50% FLT, and decreases more at 25% FLT. Efficiency only becomes poor below 25% FLT. The variation of efficiency with loading and speed is shown in Figure 15.30, parts c and d.

15.4.6ii Background to induction machine starting

Traditionally there are several ways to start three-phase ac induction motors. Starting via the use of series resistors and chokes/reactors or shunt capacitors are not considered.

Direct-on-line starting DoL

The simplest starting approach is to connect the motor to the ac voltage power supply via contactors and overload relays, and start the motor at full line voltage. This method is called *direct-on-line* (DoL) motor starting. The motor high in-rush current (locked rotor current) can be 5 to 10 times the motor full load current, as seen in figure 15.30b. These high starting currents cause voltage dips and sag in a weak power supply system. DoL starting also causes excessive torques in the mechanical system being driven, causing undesirable shocks among mechanical components, such as gears, belts, sheaves, and connections. Systems exposed to such shock will require frequent inspection and maintenance that lead to costly down-time.

Other viable approaches for electromechanical reduced-voltage starting use either a three-phase step-down auto-transformer or wye-delta starters.

Autotransformer starting

An auto-transformer is a non-isolating transformer that can be tapped to deliver any percentage (including >100%) of full voltage, for example 58%. By starting the motor at reduced voltage, electromechanical starters are able to crudely reduce the in-rush current and developed torque. Although the voltage is increased in limited steps, there are sudden current changes and mechanical shock during transitions.

Motor-start rated circuit breakers (slow opening operation to current surges) replace standard circuit breakers for starting motors of a few kilowatts. This interlocked breaker accepts high over-current for the duration of starting. In figure 15.31a, closure of the start contacts S applies reduced voltage during the start interval. The S contacts open and the run contacts R close after starting. This reduces the starting current to, say, 200% of full-load current. Since the autotransformer is only used for the short start interval, it may be sized considerably smaller than for a continuous duty application. By controlling two phases, which defines the third phase current, the three autotransformer version can be reduced to two auto-transformers, as shown in figure 15.31b, if phase current imbalances can be tolerated for the short transient start-up period.

The basic auto-transformer starter has the disadvantage that at the contactor transition instant from 'start' to 'run' the supply to the motor is interrupted, termed an *open transition start*. This means that the electrical system insulation is stressed by the resultant high transient voltages. A *closed transition start* method keeps the motor connected to the supply continuously by means of the connection shown in figures 15.31, parts c and d for two and three controlled phases respectively.

The three start-up sequence of stages, for one phase of the three machine phases, are shown in part e of figure 15.31, which can be described as follows:

- First *Stage-1*, switches L and S close and the motor accelerates at a reduced voltage determined by the autotransformer tapping.
- Then the second *Stage-2*, the star point of the transformer (switch S) is opened so that the motor continues to run with part of the transformer winding in circuit.
- Next, *Stage-3*, this winding section is short-circuited by the 'run' contactor or switch (switch R closes).

The initial starting line current is approximately

$$\text{Starting Current} = 1.1 \times \left(\frac{\text{applied voltage}}{\text{full voltage}} \right)^2 \times \text{standstill current with full volts} \quad (15.121)$$

The factor of 1.1 compensates for the auto-transformer magnetizing current.

The initial starting torque is approximately

$$\text{Starting torque} = \left(\frac{\text{applied voltage}}{\text{full voltage}} \right)^2 \times \text{standstill torque with full volts} \quad (15.122)$$

These formulae for initial starting current and torque are approximate because it is assumed for simplicity that the standstill-reactance of a motor is constant at all voltages, that is, the short-circuit current varies in direct proportion to the applied voltage. Owing to magnetic saturation, particularly of the machine slot tips, the standstill reactance tends to be less on full volts than on reduced volts so the current and torque values tend to be less than those given by the formulae.

A fully automatic three-phase starter comprises a triple-pole line contactor, start contactor, running contactor, three single-pole overload relays, auto-transformer with a set of links for tap-changing, a suitable timer, and 'start' and 'stop' pushbuttons. The two auto-transformer version shown in figure 15.31d, reduces the number of poles needed on the start, S, and run, R, contactors, from three poles to two poles.

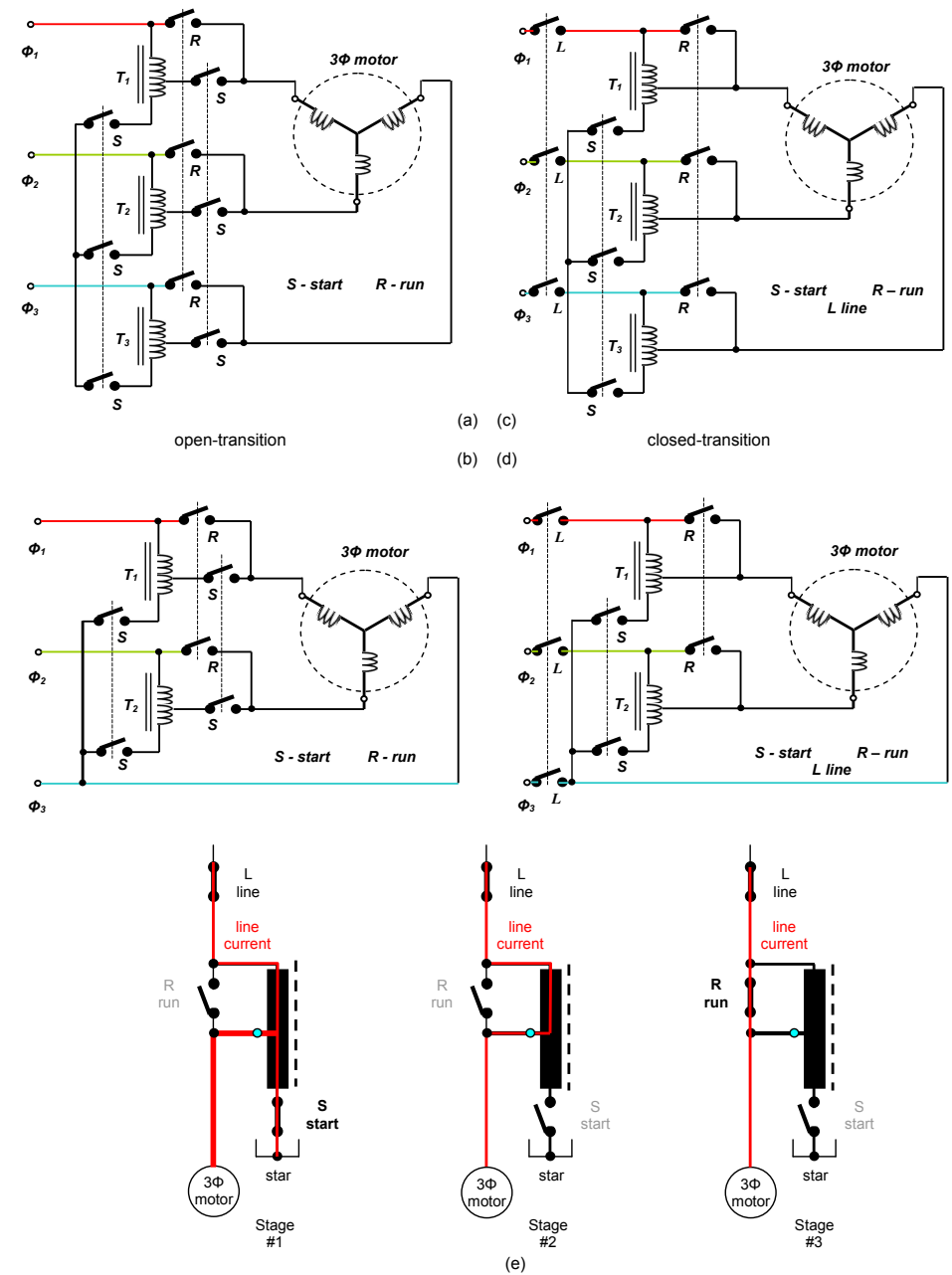

Figure 15.31. Basic auto-transformer induction motor starter, with two and three-phase independent control: (a) and (b) open transition switching sequence, (c) and (d) closed transition switching sequence, and (e) three stages of the closed transition switching sequence.

Star-delta or wye-delta starter

From equations (15.121) and (15.122), reduced voltage starting utilises the fact that motor torque and current are proportional to the square of the terminal voltage. This is exploited in the most familiar type of reduced-voltage starter, namely the star-delta or wye-delta starter, shown in figure 15.32. The star-delta starter consists of three contactors and a time switch (which can be mechanical, pneumatic, electrical or electronic). With the wye-delta starter, the special winding terminated motor (access to three individual windings) is first run as a wye motor so each motor winding only experiences 58% of full voltage, $1/\sqrt{3}$. After a set period-of-time, the starter switches to run the motor as a delta connected motor and the motor windings experience the full ac line voltage. The change-over is controlled by the timer switch and is usually arranged to switch at 80% of full speed. The effect of starting in star, with each stator winding voltage reduced to 58%, $1/\sqrt{3}$, of normal, is a reduction in the starting torque to a third of locked rotor torque (LRT) with a consequential reduction in starting current and acceleration force. Effectively, the voltage is reduced by a 1.732 factor, $\sqrt{3}$. The impedance seen by the power system is 3 times the impedance of the delta run connection. The starting sequence and resultant torque/current characteristics are shown in figure 15.37. For Wye Start, Delta Run, the starting characteristics are:

- starting current is approximately 30% of that obtained with the normal delta connection.
- starting torque is approximately 25-30% of that realised with the normal delta connection.

This starting method is only viable when the system is light loaded during the start. Although an improvement over the DoL system, disadvantages remain.

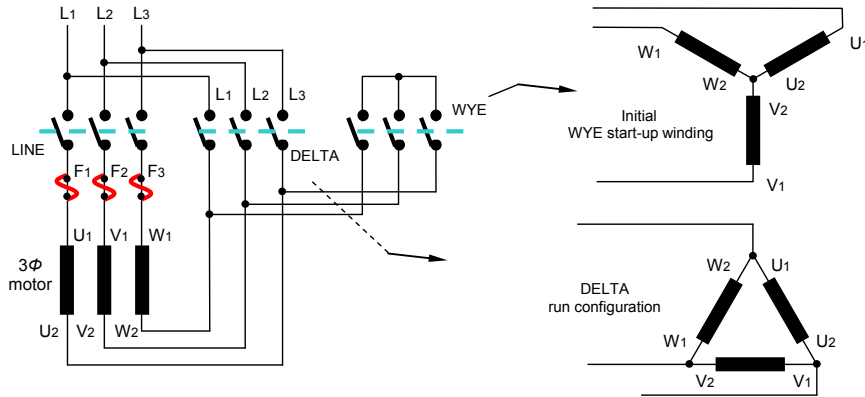

Figure 15.32. Basic wye-start, delta-run connection configuration for induction motor starting.

The transfer from a star to a delta connection momentarily disconnects the motor from the supply. During this time it is under the mechanical influence of the rotating load and, at the instant of disconnection, current continues to flow in the rotor bars due to the long time delay necessary for the magnetic flux to die away. Therefore, there is a residual flux 'frozen' on the surface of the rotating rotor, which cuts the stator windings, generating a voltage whose frequency depends on rotor speed. If the load inertia is small, such as in a pump, or if the friction is high, there could be a significant loss of speed during the time the supply is disconnected. In this case, when the delta run connection is made, a large phase differential can exist between the supply and the rotor fluxes. This can give rise to large current surges, possibly more than the full-voltage locked rotor current, together with large transient torque oscillations, as much as five times full-load torque. Although the effects are only transitory, typically one fifth of a second, they are sources of stress and potential damage to the drive system, and where frequent starting is necessary, incur high maintenance costs.

There are methods of control, for example, the closed transition starter, which eliminate or reduce the reconnection transients. However, such starters are expensive and have reliability implications; for these reasons, they are not widely utilised. The star-delta starter also has disadvantages due to the restricted starting torque available. If 40% LRT is needed to breakaway, the motor size must be increased or direct-on-line starting is re-employed. Combined with the severe effects of the re-switching surges and the additional costs of bringing six cables from the motor to the starter instead of only three, star-delta starting offers a less than ideal solution to the problem of induction motor starting.

As a starting alternative, auto-transformers and wye-delta starters are large and require extra wiring. Solid-state starting technology can overcome many of the problems associated with mechanical based starters and can provide stepless soft-starting of three-phase ac caged induction motors.

15.4.6iii Solid-state soft-starter

The solid-state switches, in figure 15.19 for example, are phase controlled in a similar manner to a light dimmer, in that they are turned on for a part of each ac cycle. The rms voltage is controlled by varying the conduction angle of the switches. Decreasing the delay angle, α (increasing the conduction angle), as shown in figure 15.33, increases the rms output voltage. Controlling the rms output voltage by means of solid-state switches has a number of advantages, one being the improvement in system efficiency, due to the low on-state voltage of SCR solid-state switches. Another advantage of the solid-state starter is that the rms voltage can be easily altered to suit the required starting conditions. By varying the conduction angle, the output voltage can be increased or reduced, and this can be achieved automatically by the control electronics. The control electronics can be pre-programmed to provide a particular output voltage contour based on a timed sequence (open loop), or can dynamically control the output voltage to achieve an output profile based on measurements of characteristics such as current and speed (closed loop).

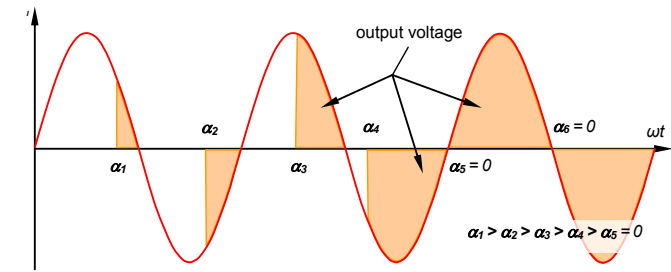

Figure 15.33. Smoothly ramped-up motor voltage by controlling the SCR's firing angle, α .

Switching elements

Voltage control is achieved by means of solid-state ac switches in series with one or more phases. The ac switch possibilities comprise any of the combinations in figure 15.34.

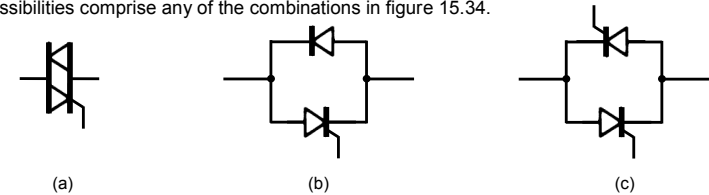

Figure 15.34. Possible ac switch combinations per phase:

(a) a triac; (b) SCR and diode reverse parallel; and (c) reverse parallel connected SCRs.

The switching elements must be able to control the current applied to the motor at line voltage. In order to maintain high reliability, the switching elements need to be rated at least three times the line voltage. On a 400V ac supply, this means that the requirement is for 1200V (dc, bidirectional) devices, and 600V devices on a 200V ac supply. It is also important that the switching elements have a high transient current overload capacity. 1200V triacs with robust current transient overload characteristics are not readily available, so the choice is between the SCR-Diode and SCR-SCR for 400V ac applications. The major differences between the SCR-SCR option in figure 15.34c and the SCR-Diode options in figure 15.34b are cost and the harmonic content of the output voltage. The SCR-SCR approach provides a symmetrical output which is technically desirable from the point of supply disturbances and harmonics, while the SCR-Diode combination is inferior technically, it is commercially more effective and easier to implement. Harmonic regulation requirements have drastically reduced the viability of SCR-Diode type soft starters.

The solid-state soft-starter can be designed to control:

- one phase, reducing the torque but not the current in two phases, (SCR/Diode cannot be used in this connection), Fig. 15.35a, or
- two phases reducing the torque but the current will not be optimally reduced or balanced, there will be negative sequence currents heating the rotor and reducing the torque per unit start current, (SCR/Diode cannot be used in this connection), Fig. 15.35b or
- three phases, reducing current and torque, providing the optimum results for torque generated per unit of start current, Fig. 15.35c. The SCR/diode combination can be used.

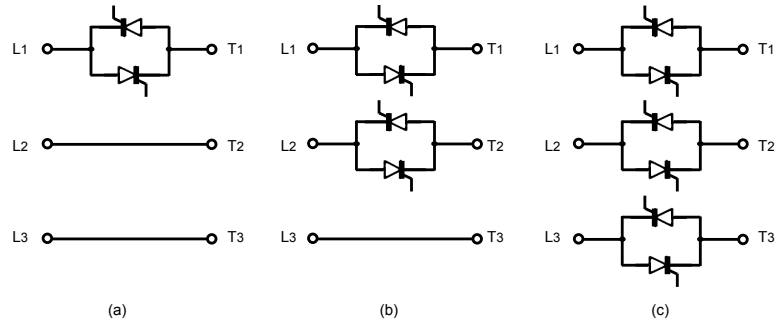

Figure 15.35. Three possible line configurations:

(a) single phase control; (b) control of two phases; and (c) three-phase fully-controlled regulator.

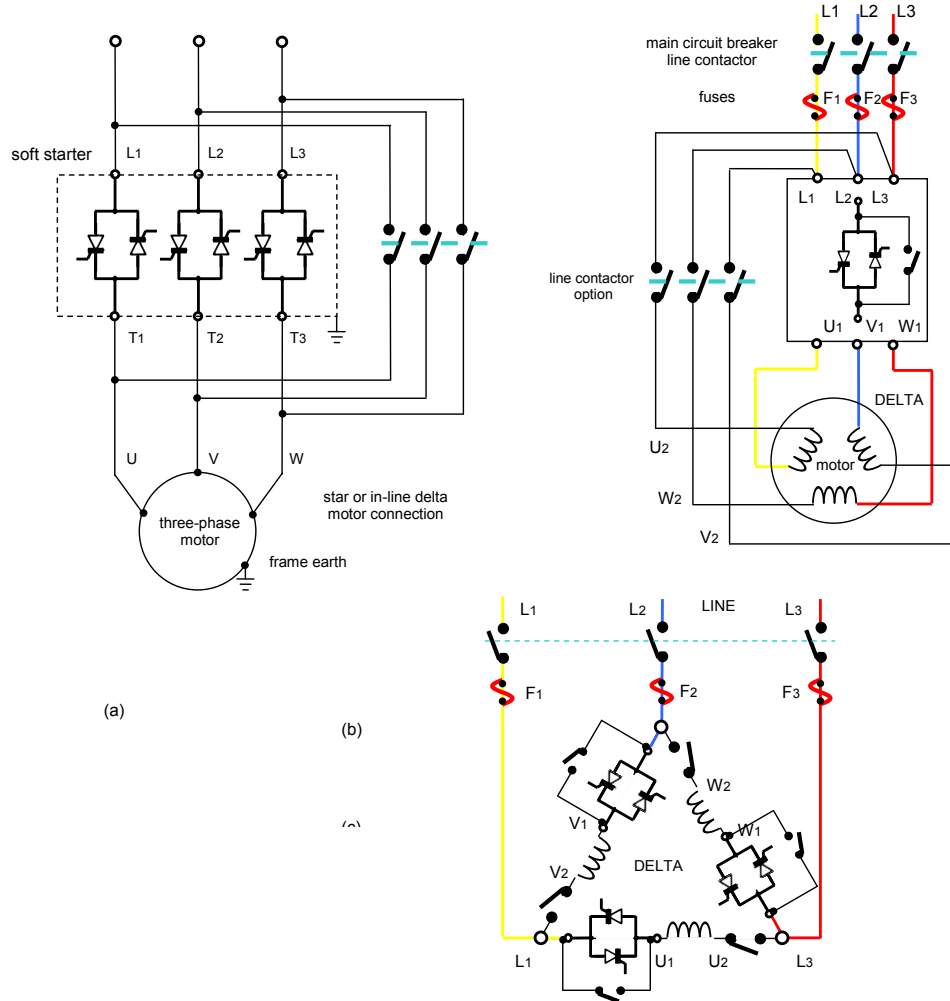

Figure 15.36. Three-phase voltage control of caged three-phase ac induction motor: (a) line delta or star controlled and (b) and (c) control within an in-delta configuration, both with a bypass relay.

Solid-state soft-starter arrangements

A reduced ac voltage can be delivered to a motor by controlling an SCR's firing angle, as illustrated in Figure 15.33. This SCR's firing angle control can ramp the voltage smoothly to full rating with the motor-controller connection configurations shown in Figure 15.36. Figure 15.37 shows that the in-rush current with electronic soft starters is much lower, as is the starting torque available from the motor, compared with DoL and a star-delta starter. Therefore, both voltage dips and mechanical shock are reduced considerably with solid-state soft starters.

In the in-delta circuit configuration in figures 15.36b/c the individual phases of the switching devices are connected in series with the individual motor windings (6 conductor connections as with the star-delta starter). The soft starter conducts about 58% of the rated motor current. This allows the use of a significantly smaller device than the in-line approach, which only requires three motor connections, as shown in figure 15.36a.

By using a by-pass contactor across the semiconductor switches, as shown in figure 15.36a, the soft-starter power losses are reduced. Additionally, since the starter is only functional during short infrequent start/stop periods, it is possible to reduce the starter enclosure size and use a higher IP-class since air ventilation is not required.

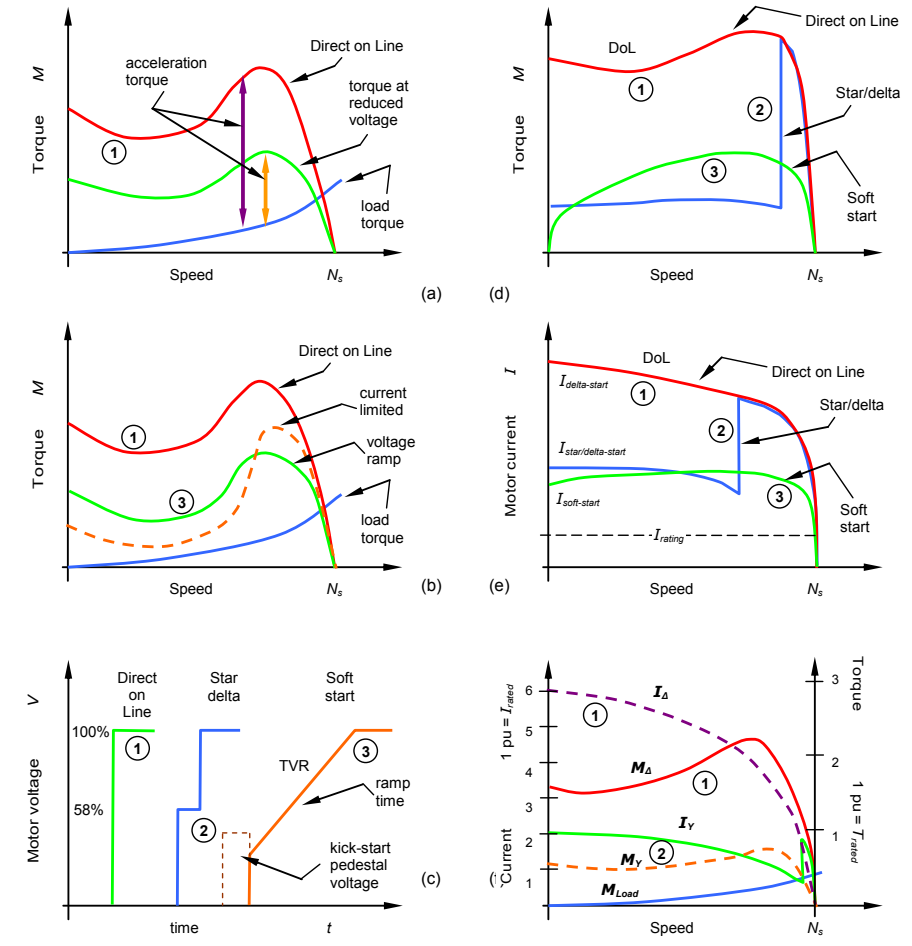

Figure 15.37. Characteristics showing why solid-state soft starters significantly reduce voltage dip and mechanical shock.

Solid-state soft starters can be connected in series with the line voltage applied to the motor (three-wire or standard connection) as in figure 15.36a, or can be connected inside the delta loop of a delta connected motor, controlling the voltage applied to each winding (six-wire or inside delta connection) as in figure 15.36b/c. There are usually three pairs of SCRs to control the voltage to a three-phase ac induction motor, that is, one pair for each phase, figure 15.36. Because SCRs are power components, they generate approximately 1W/A per phase of heat when on and the heat sink must dissipate the heat generated. Both the SCRs and the heat sink are components that add to the costs.

Because a three-phase motor is a three-wire system, the Kirchhoff sum of its three-phase currents is constrained to zero at any instant. If the currents in two of the three phases are reduced, the current to the third phase will be reduced as well, even when the third phase is directly connected to the full line voltage. A two-phase-controlled solid-state soft starter based on figure 15.35b, is able to control the three-phase currents and since only two pairs of SCRs are used, it has a smaller heat sink. Fewer SCRs and a smaller heat sink reduce the cost and size. Compared to an electromechanical starter, it offers superior performance in a compact size, where the cost of parts, installation, and maintenance are lower.

A two-phase-controlled soft-starter can cause undesirable acoustical noise on larger motors at voltages less than 50%. The cause of the audible noise is related to the dc component in the phase current, which causes additional heating. Because of shorter starting times, motor heating is minimal. Polarity balancing control, balances the current in positive half and negative half cycles, eliminating the dc components. Then motors can be started at voltages less than 50% of full rating. This feature is particular applicable when soft starting a fan motor or pump motor at light load or no-load during the start period. Polarity balancing cannot balance the currents among the three phases and the phase without SCR control will have higher current. The imbalance between the three-phase currents is intrinsic to two-phase control and cannot be influenced. Because the imbalance among the three currents is generally within 10 to 25%, it is not critical in applications where the motor load reaches full speed quickly.

A three-phase fully-controlled soft-starter is applicable if balanced phase currents are essential to within 10%.

The functional block diagram in figure 15.38 shows a three-phase controlled soft-starter which offers features that include:

- polarity balancing control allowing the motor to start at less than 50% full voltage
- integrated ac motor thermal protection
- selectable motor overload trip level
- adjustable current limiting, start time, stop time, and starting voltage
- built in by-pass contactors
- detection of phase failure, faulty control voltage, locked rotor, SCR overheating, etc.

Design features particular to power electronics knowhow include the use of isolating pulse transformers for SCR triggering and R-C snubbers across the SCRs. Series snubber resistors are used not so much because of the necessary power rating but to achieve the required 1200V voltage rating. Two series snubber resistors allows low cost, low voltage, low inductance resistors to be used.

15.4.6iv Soft-starter control and application

Open-loop control and the start voltage profile

Open-loop soft starters produce a start voltage profile which is independent of the current drawn, or the speed of the motor.

The start voltage profile is programmed to follow a predetermined contour against time, as shown in figure 15.37c. A basic Timed Voltage Ramp (TVR) system operates by applying an initial voltage to the motor, possibly involving a kick-start pedestal voltage, then slowly ramps from this voltage up to full voltage. On basic systems, the initial start voltage is not adjustable, but the ramp time is and may be a simple linear ramp or a complex shape to emulate a controlled current start. The voltage ramp time is referred to as the acceleration ramp time. This is not an accurate description, as it does not directly control the acceleration of the motor. Technically, it should be referred to as the voltage ramp time. On more sophisticated controllers, the start voltage is pre-settable, typically from 10% to 70% of full line voltage, and is set to achieve at least breakaway torque for the motor at start. There is no advantage in the motor stalling or straining to start due to insufficient torque. Eventually full voltage is applied under locked rotor load conditions, producing locked rotor torque and current which increases the heat dissipated in the motor, until any protection trips or failure. The starter does not have any programmed knowledge of the connected motor, so is unable to deliver a prescribed amount of torque under open loop conditions. The actual start torque produced is given by equation (15.121). The motor LRT can vary from as low as 60% FLT to as high as 350% FLT which is a range of almost 6 to 1.

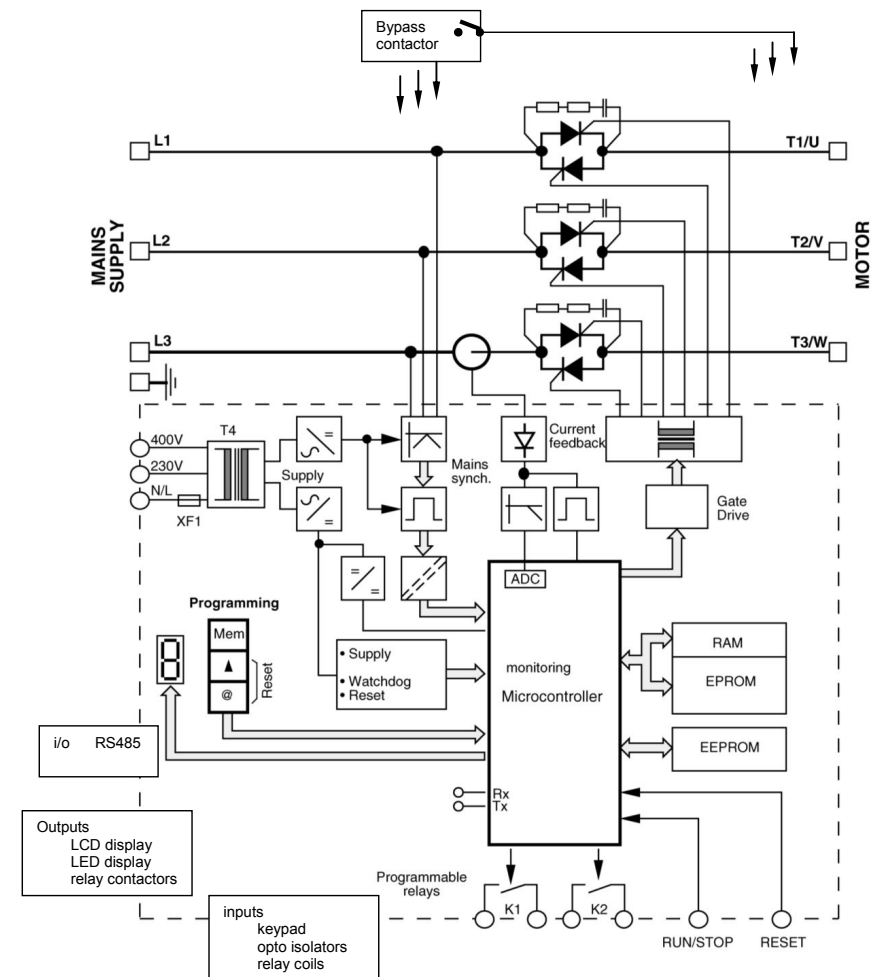

Figure 15.38. Functional block diagram of three-phase controlled SCR based soft starter, with voltage and current feedback control, with optional bypass contactor.

Closed-Loop Control

Closed-loop soft-starters monitor an output characteristic or effect from the starting action and dynamically modify the start voltage profile to cause the desired response. The most common closed loop soft starter is the controlled current soft starter where the current drawn by the motor during start is monitored and controlled to give either a constant current, as shown in figure 15.37b, or a current ramp soft start. Another closed loop strategy is the constant acceleration soft start where the motor speed is monitored by a tachogenerator or shaft encoder and the voltage is controlled to maintain a constant rate of acceleration or a linear increase in motor speed. Closed-loop control can take the following forms.

- In basic closed loop systems, the soft starter is essentially a standard TVR soft starter with a ramp option where the current in one phase is monitored and compared to a set point. If the current exceeds the set point, the ramp is frozen until the current drops below that set point. At the other complexity extreme, a comprehensive closed loop soft starter monitors the current in two phases (effectively in all three phases) and dynamically changes the output voltage to correct the start current to the required profile. This system is able to both increase and reduce the start voltage to suit the control needs, and attempts to minimise any dc current component.

- ii. A constant current starter commences at zero volts and rapidly increases the output voltage until the required current is delivered to the motor, and then adjusts the output voltage during motor starting until either full voltage is reached, or the motor overload protection operates. With a controlled current soft starter, the voltage reduction reduces as the motor accelerates due to the rising motor impedance. As the motor approaches full speed, the voltage rises quickly (against speed) to full voltage. When the torque curve for a motor started by a constant current starter is compared with that of a constant voltage starter such as an autotransformer starter, there is an increase in the torque as the motor accelerates with a constant current start. This is ideal because as the motor increases in speed, the actual load on the motor shaft increases. This characteristic enables a load to be started with a lower current on a soft starter than traditional starter methods. Constant current starters are ideal for high inertia loads, or loads with a near constant starting torque load requirements.
- iii. The current ramp soft starter operates in the same manner as the constant current soft starter except that the current is ramped from an initial start current to a current limit setting over a period of time. The initial start current, current limit, and ramp time are all user adjustable to suit the application. Machines requiring a varying starting torque, such as load conveyers, or applications requiring a reduced initial torque such as pumping applications, or genset applications where the relatively slow application of current load will allow the genset to track the load, are examples where the current ramp soft start can be used to advantage over a constant-current soft-starter.
- iv. In a torque control starter, the controller models the motor under high-slip and low-slip conditions and uses a mathematical model to calculate the current and shaft torque being produced by the motor. These are then used as a feedback source with the square law reduced start torque and current curves, given by equations (15.121) and (15.122), being used to control the start voltage applied to the motor. The torque curve generated by equation (15.121) can be superimposed onto the load speed torque curve, and provided the torque developed at all speeds exceeds the load torque, the motor accelerates to full speed. If the curves cross, the start current (or voltage) are increased to increase the motor starting torque. The difference between the developed and the load torques is the acceleration torque that accelerates the machine to full speed. A high acceleration torque may be desirable for a high inertia load in order to minimize the starting time.

Methods of stopping

Soft-stop

Soft-starters inherently incorporate soft-stop, which is the opposite to soft-start. The voltage is gradually reduced, reducing the torque capacity of the motor. The reduction of available torque causes the motor to decelerate when the motor shaft torque is less than the torque required by the load. As the torque is reduced, the speed of the load is reduced to the point where the load torque equals the shaft torque.

Typically, soft stop is achieved using an open loop voltage ramp, but a torque control soft stop system can use torque feedback to provide better deceleration control.

Open loop soft stop performance is dependent on the characteristics of the motor and driven load. On larger machines this can be non-linear, hence provides poor performance.

Soft slope effectively adds inertia to the load and extends the braking time. It should only be applied to installations where the stopping time is too short and needs to be extended. Soft stop does not provide braking, and occurs over a period longer than it would take the rotational system to coast to standstill without any power applied.

DC braking

DC braking is used to apply a braking torque to the motor and load, making them stop quicker. Software controlled dc braking is possible for soft starters, but is not as effective as the braking that can be achieved with a specific dc brake electronic circuit.

Software

DC braking using the soft starter is achieved by turning on a positive SCR in one phase and a negative SCR on in a second phase for a small angle of each cycle. This causes a high pulse of dc current to flow through the motor windings and creates a stationary torque field in the stator. This causes the motor to slow down. The short pulses at line frequency also produce a synchronous component in the torque field that can limit the effectiveness close to synchronous speed. In some cases, a shorting contactor is connected across a motor winding to prolong the period of current flow and reduce the line frequency component.

During dc braking, the energy of the driven load is dissipated in the rotor of the motor.

Hardware

A stop button, with two interlocked contactors initiates braking, as shown in figure 15.39, where a dedicated thyristor/diode braking circuit is shown.

An induction motor with high-inertial load can be quickly stop by circulating dc current in a stator winding, where any two stator terminals can be connected to a dc source such that the resultant dc current produces stationary N-S poles in the stator. Since the number of stationary poles is the same as the number of rotating poles normally produced with ac currents, as the rotor bars sweeps past the dc field, an ac rotor voltage is induced.

The I^2R loss produced in the rotor circuit is converted kinetic energy stored previously in the rotating masses, hence the motor comes to rest by dissipating all the kinetic energy as heat.

The benefit of dc braking is that efficient heat is produced, since the dissipated rotor losses are equal to the kinetic energy of the rotating masses and are independent of the dc current magnitude, while the braking torque is proportional to the square of the dc current.

DC injection duration and frequency of occurrence should be minimised in order to minimise motor heating.

The dc injection braking procedure shown in figure 15.39b, is as follows:

- The motor contactor C_{motor} is opened, then after a delay of 200ms to 2.5s (increased time as motor rating increases), the braking contactor C_{brake} is closed, which allows the motor back emf to reduce. Any overlap between C_{motor} and C_{brake} is prevented by using interlocked contactors.
- After a further 50ms delay, dc current is injected into two motor winding by firing the braking thyristor, until rotation stops. This second 50ms delays allows an ac breaking contactor C_{brake} to be used, since dc current switching is avoided. The braking torque is a function of dc current, which is controlled by the thyristor firing angle.
- After the thyristor triggering is removed (always before or when to rotor comes to a standstill), a delay of 200ms to 2s (increased time as motor rating increases) is allowed before the braking contactor C_{brake} is opened, in order to avoid braking a dc current.
- 200ms after the braking contactor C_{brake} is opened, the motor can be enabled by closing the motoring contactor, C_{motor} .

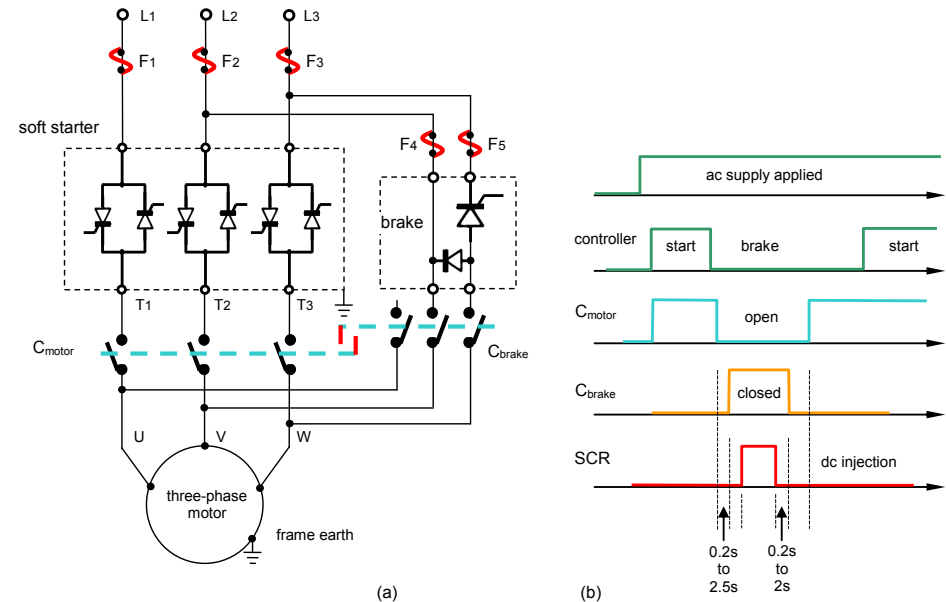

Figure 15.39. Braking circuit: (a) circuit connection and (b) timing sequence and delay times.

Reversing and plugging

A mechanical contactor based reversing arrangement is shown in figure 15.40a, which uses two interlocked contactors. Contactors and fusing for reversing circuits are only used between the line and the soft-starter.

It is required, with this contactor arrangement, to insert a 150ms to 350ms delay between the opening of one contactor and the closing of the other, to allow any residual flux in the rotor to decay away. Figure 15.40c shows the machine torque and current conditions when the machine is reversed whilst operating at or near rated torque/speed, point A. On reversing two phase connections, the operating point A moves to point B, which represents a deceleration torque with a high machine current, point C. The machine accelerates to operating point D as a result of stopping and reversing rotation in a direction opposite to the original rotating direction. In attempting to traverse from point A to point D, the rotation passes through zero speed point E, at which time the controller is phased back to zero thyristor conduction. When plug-braking, (phase reversal at full voltage) there should be some form of zero-speed detection to stop the drive after braking has been completed, otherwise the drive may either accelerate the motor in the reverse direction or switch off before zero speed has been reached.

A solid state solution to reversing and plugging is shown in figure 15.39b, which requires two extra sets of back-to-back parallel connected thyristors.

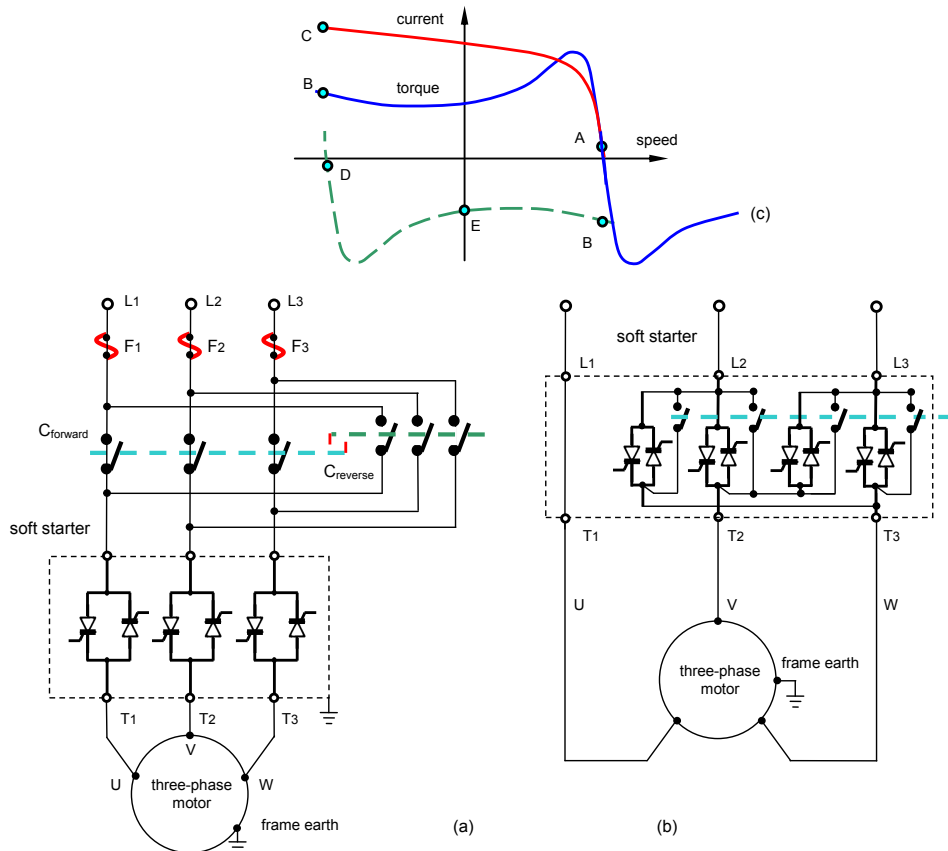

Figure 15.40. Reversing circuit: (a) mechanical contactor reversing; (b) electronic reversing (4 quadrant) with mechanical contactor bypassing; and (c) torque and current characteristic of reversal of two phase voltages.

Ratings

As the rating of the soft-starter is essentially thermal, there is a strong relationship between the start time, start current, start/stop frequency of occurrence, ambient temperature, off-time, and the rating of the starter. Typically, the thermal inertia of the SCR heatsink assembly is long so there is not a large variation in the rating between say a 10-second rating and a 30-second rating. At altitudes above 1000m the rated current is usually derated at about 7% per 1000m increase in altitude, up to 4000m.

Harmonics

Harmonics are unwanted voltages and currents in almost every electrical system and are a multiple of the rated ac mains frequency. Typical harmonics are odd, viz., 3rd, 5th, 7th, 9th, etc., which contribute to the unnecessary heating of motors, cables and other equipment and may shorten the lifetime of these devices if exposed for a long period of time.

The resultant EMC may disturb or interfere with other local electronic systems. Soft-starters generally fulfil EMC directives (EN 60947-4-2) on emission (EN55011 Class A) and immunity (IEC 6 1000-4/ 2 to 6) since their operation is non-continuous and intermittent.

Fuses

Standard IEC 60947-4-2 defines two types of co-ordination according to the expected level of service continuity. Co-ordination requires that, under short-circuit conditions:

Type #1: The soft-starter device shall cause no danger to persons or installation and may not be suitable for further service without repair and replacement of parts.

Type #2: The soft-starter device shall cause no danger to persons or installation and shall be suitable for continued use. For hybrid controllers and starters, contact welding is a possibility, in which case equipment maintenance is required.

Semiconductor fuse curves do not follow the ratings curves for soft starters and only offer short circuit protection. Semiconductor fuses (high speed fuses) are the only type of fuses that are fast enough to achieve type 2 co-ordination when using a soft-starter. A separate overload relay for motor protection is required in combination with this type of fuse. If the semi-conductor fuses is replaced with an MCB, protection reverts to type 1 co-ordination.

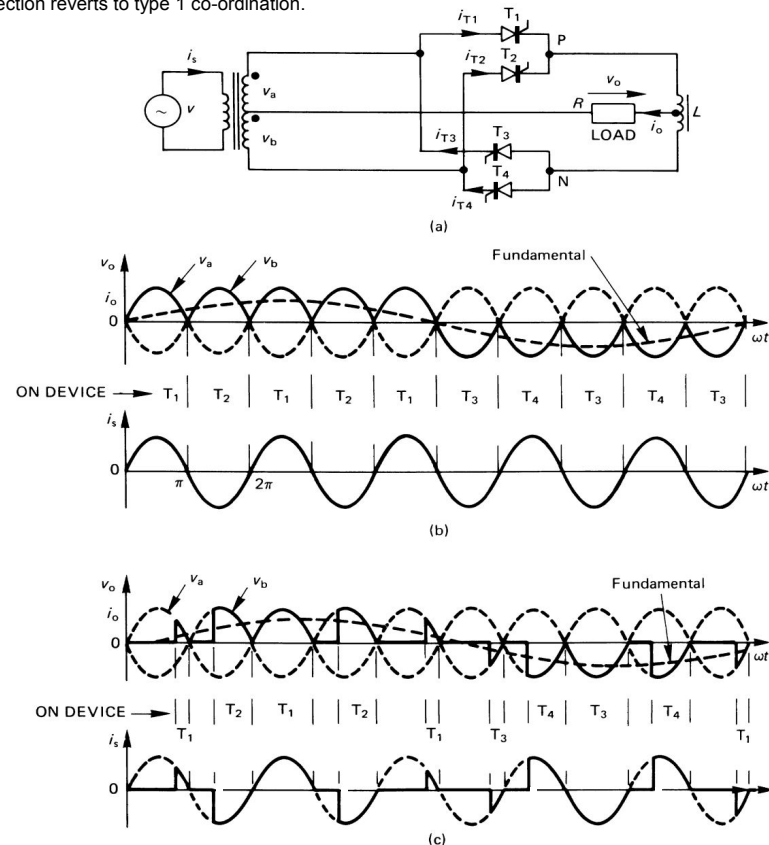

Figure 15.41. Single-phase cycloconverter ac regulator: (a) circuit connection with a purely resistive load; (b) load voltage and supply current with 180° conduction of each thyristor; and (c) waveforms when phase control is used on each thyristor.

15.5 Cycloconverter

The simplest cycloconverter is a single-phase, two-pulse, ac input to single-phase ac output circuit as shown in figure 15.41a. It synthesises a low-frequency ac output from selected portions of a higher-frequency ac voltage source and consists of two converters connected back-to-back. Thyristors T_1 and T_2 form the positive converter group P, while T_3 and T_4 form the negative converter group N.

Figure 15.41b shows how an output frequency of one-fifth of the input supply frequency is generated. The P group conducts for five half-cycles (with T_1 and T_2 alternately conducting), then the N group conducts for five half-cycles (with T_3 and T_4 alternately conducting). The result is an output voltage waveform with a fundamental of one-fifth the supply with continuous load and supply current. The harmonics in the load waveform can be reduced and rms voltage controlled by using phase control as shown in figure 15.41c. The phase control delay angle is greater towards the group changeover portions of the output waveform. The supply current is now distorted and contains a subharmonic at the cycloconverter output frequency, which for figure 15.41c is at one-fifth the supply frequency.

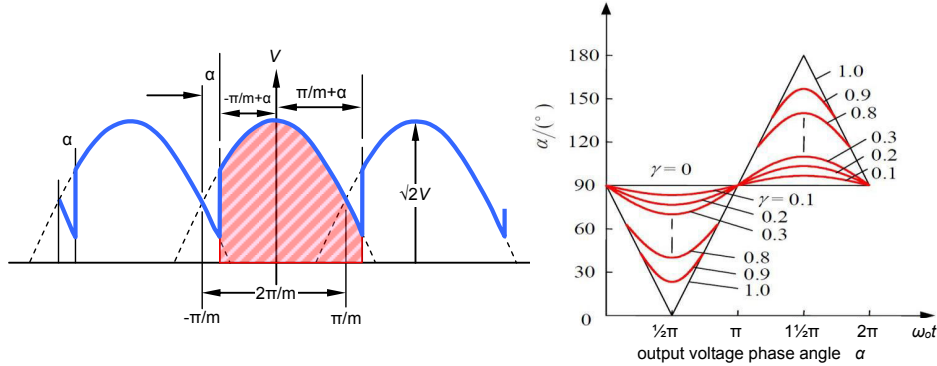

Figure 15.42. Converter m -phase output voltage with firing delay angle α and modulation factor γ .

In figure 15.42, if the firing delay angle α , the conduction period is from $-\pi/m + \alpha$ to $+\pi/m + \alpha$, such that the conduction period is $2\pi/m$. The average output voltage is

$$V_{dc} = \frac{m}{2\pi} \int_{-\pi/m + \alpha}^{+\pi/m + \alpha} \sqrt{2}V \cos \omega t \, d\omega t = \sqrt{2}V \frac{m}{\pi} \sin \frac{m}{\pi} \times \cos \alpha$$

For the cycloconverter output

$$v_o(t) = \sqrt{2}V_o \sin \omega_o t$$

Equating gives

$$\cos \alpha = \frac{\sqrt{2}V_o}{\sqrt{2}V \frac{m}{\pi} \sin \frac{m}{\pi}} \sin \omega_o t = \gamma \sin \omega_o t$$

That is

$$\alpha = \cos^{-1}(\gamma \sin \omega_o t)$$

where γ is the output voltage modulation factor.

With inductive loads, one blocking group cannot be turned on until the load current through the other group has fallen to zero, otherwise the supply will be short-circuited. An intergroup reactor, L , as shown in figure 15.41a can be used to limit any inter-group circulating current, and to maintain a continuous load current.

A single-phase ac load fed from a three-phase ac supply, and three-phase ac load cycloconverters can also be realised as shown in figures 15.43a and both of 15.43b and c, respectively. A transformer is needed in figure 15.43a, if neutral current is to be avoided. The three-pulse per ac cycle cycloconverter in figure 15.43b uses 18 thyristors, while the 6-pulse cycloconverter in figure 15.43c uses 36 thyristors (inter-group reactors are not shown), where the load (motor) neutral connection is optional. The output frequency, with considerable harmonic content, is limited to about 40% of the input frequency, and motor reversal and regeneration are achievable.

If a common neutral is used, no transformer is necessary. Most cycloconverters are 6-pulse, and the neutral connection in figure 15.43c removes the zero sequence component.

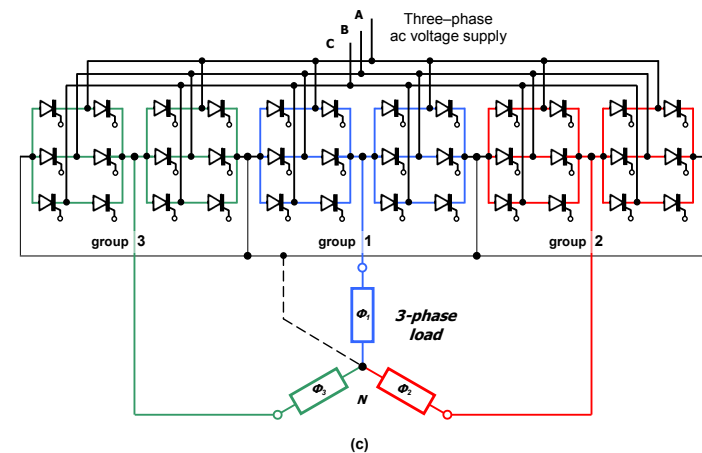
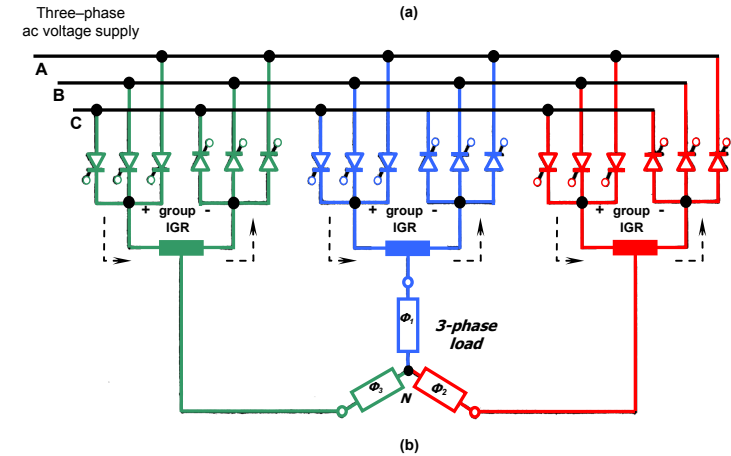
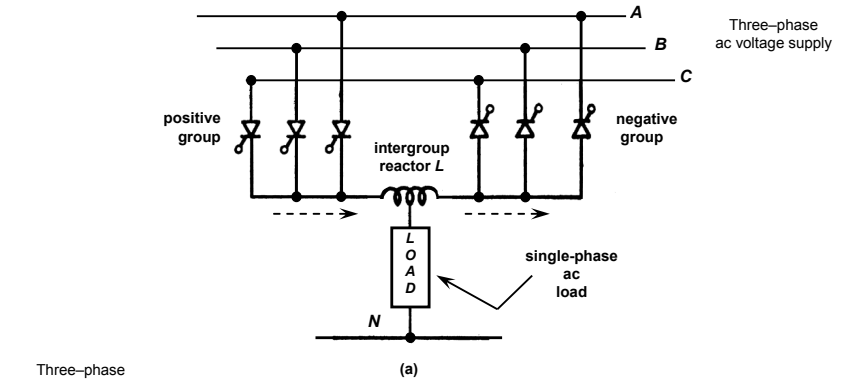

Figure 15.43. Cycloconverter ac regulator circuits: (a) three-phase to single-phase; and three-phase supply to three-phase load (b) 3-pulse without neutral connection; and (c) 6-pulse with optional load neutral connection.

The positive features of the cycloconverter are

- Natural commutation
- No intermediate energy storage stage
- Inherently reversible current and voltage

The adverse features of the cycloconverter are

- High harmonics on the input and output
- Requires at least 18 thyristors usually 36
- High reactive power

15.6 Three phase fixed frequency hexagonal ac to ac converter

At ac voltages above 3.3kV, series connection of thyristors and/or a 50/60Hz three-phase transformer is usually necessary in the fixed frequency ac to ac converters considered in this chapter. The hexagonal chopper converter in figure 15.44 uses an MMC approach (figure 15.44b) to facilitate voltage balanced series connection of IGBT devices, as three phase version of the single phase chopper converters in section 15.3. Similarly, the fundamental magnitude of the output voltage is proportional to duty cycle.

The MMC cell capacitor is used for device voltage clamping, unlike the HVDC MMC converter where the cell capacitor actually conducts load current. The bidirectional cells operate to production quasi square wave transitions (figure 15.44c), whence cell capacitance (which is dependent on the chopping frequency) is smaller than in MMC HVDC applications. Being a three phase system, cell capacitor voltage balancing (using capacitor voltage magnitude sorting) can be assured over one ac cycle.

Because of the balanced series cell connection properties, and having a fixed, equal input and output frequency, the hexagonal topology is applicable to the shunt and series FACT devices presented in Chapter 25.

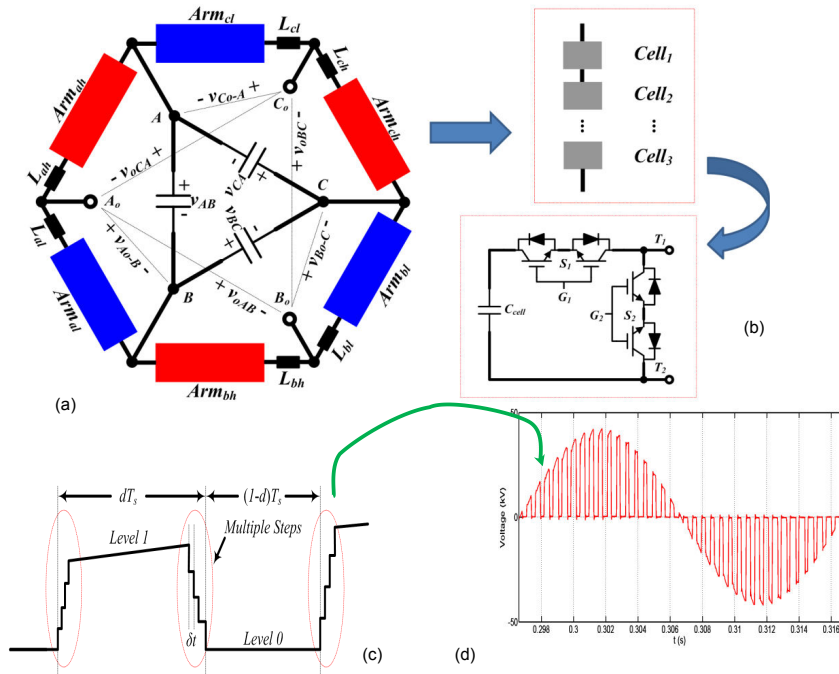

Figure 15.44. Three-phase hexagonal ac to ac chopper converter: (a) topology, (b) bidirectional MMC cell structure, (c) typical level transitions, and (d) chopped 50Hz waveform of one phase.

15.7 The matrix converter

Commutation of the cycloconverter switches is restricted to natural commutation instances dictated by the supply voltages. This usually results in the output frequency being significantly less than the supply frequency if a reasonable low harmonic output is required. In the matrix converter in figure 15.45c, the thyristors in figure 15.43b are replaced with fully controlled, bidirectional switches, like those shown in figures 15.45a and b. Rather than eighteen switches and eighteen diodes, nine switches and thirty-six diodes can be used if a unidirectional voltage and current switch in a full-bridge configuration is used as shown in figure 7.12. These switch configurations allow converter current commutation as and when desired, provide certain conditions are fulfilled. These switches allow any one input supply ac voltage and current to be directed to any one or more of the output lines. At any instant, only one of the three input voltages can be connected to a given output. This flexibility implies a higher quality output voltage can be attained, with enough degrees of freedom to ensure the input currents are sinusoidal and with unity (or adjustable) power factor. If the inputs are voltage sources, the outputs must be current sources, and vice versa. The input L-C filter prevents matrix modulation frequency components from being injected into the input three-phase ac supply system.

In the usual case of voltage source inputs and current source outputs, the switch conditions must:

- Never short-circuit two or more input phase voltages
- Never open circuit any output line current

Generally, the relationship between the n output voltages ($v_a, v_b, v_c, \dots, v_n$) and the M input voltages ($v_A, v_B, v_C, \dots, v_M$) is determined by the states of the $M \times n$ bidirectional switches (S_{ij}), where $S_{ij} = 1 =$ closed, $S_{ij} = 0 =$ open, according to

$$\begin{bmatrix} v_a \\ v_b \\ v_c \\ \vdots \\ v_n \end{bmatrix} = \begin{bmatrix} S_{Ab} & S_{Bb} & S_{Cb} & \dots & S_{Mb} \\ S_{Ab} & S_{Bb} & S_{Cb} & \dots & S_{Mb} \\ S_{Ac} & S_{Bc} & S_{Cc} & \dots & S_{Mc} \\ \vdots & \vdots & \vdots & \ddots & \vdots \\ S_{An} & S_{Bn} & S_{Cn} & \dots & S_{Mn} \end{bmatrix} \begin{bmatrix} v_A \\ v_B \\ v_C \\ \vdots \\ v_M \end{bmatrix} \quad (V) \quad V_{out} = S V_{in} \quad (15.123)$$

where S is the switch connection matrix and $i = A, B, \dots, M$ and $j = a, b, \dots, n$.

If the M inputs are voltage sources, then the switches must satisfy

$$\sum_{i=A}^M S_{ia} = \sum_{i=A}^M S_{ib} = \sum_{i=A}^M S_{ic} = \dots = \sum_{i=A}^M S_{in} = 1 \quad \sum_{i=A}^M S_{ib} \sum_{j=a}^n S_{ij} = n \quad (15.124)$$

The first set of equalities in equation (15.124) ensure that each output can only be connected (at most) to one input voltage supply, thus avoiding shorting two or more voltage inputs. Since the inputs are voltage sources, the output must be current sources, thus the second equality ensures a path for current in each of the n output phases. The relationships between the input and output currents, in terms of the switch connection matrix S , are given by

$$\begin{bmatrix} i_a \\ i_b \\ i_c \\ \vdots \\ i_n \end{bmatrix} = \begin{bmatrix} S_{Ab} & S_{Bb} & S_{Cb} & \dots & S_{Mb} \\ S_{Ab} & S_{Bb} & S_{Cb} & \dots & S_{Mb} \\ S_{Ac} & S_{Bc} & S_{Cc} & \dots & S_{Mc} \\ \vdots & \vdots & \vdots & \ddots & \vdots \\ S_{An} & S_{Bn} & S_{Cn} & \dots & S_{Mn} \end{bmatrix}^T \begin{bmatrix} i_A \\ i_B \\ i_C \\ \vdots \\ i_M \end{bmatrix} \quad (A) \quad I_{in} = S^T V_{out} \quad (15.125)$$

For the three-phase voltage input to three-phase current output matrix converter, the relationship between the output voltages (v_a, v_b, v_c) and the input voltages (v_A, v_B, v_C) is determined by the states of the nine bidirectional switches (S_{ij}), where $S_{ij} = 1 =$ closed, $S_{ij} = 0 =$ open, according to

$$\begin{bmatrix} v_a \\ v_b \\ v_c \end{bmatrix} = \begin{bmatrix} S_{Ab} & S_{Bb} & S_{Cb} \\ S_{Ab} & S_{Bb} & S_{Cb} \\ S_{Ac} & S_{Bc} & S_{Cc} \end{bmatrix} \begin{bmatrix} v_A \\ v_B \\ v_C \end{bmatrix} \quad (V) \quad V_{out} = S V_{in} \quad (15.126)$$

From Kirchhoff's voltage law, the number of switches on in each row must be either one or none, otherwise at least one input supply is shorted, that is (i refers to the input and j refers to the output)

$$\sum_{j=1}^3 S_{ij} \leq 1 \quad \text{for any } j \quad (15.127)$$

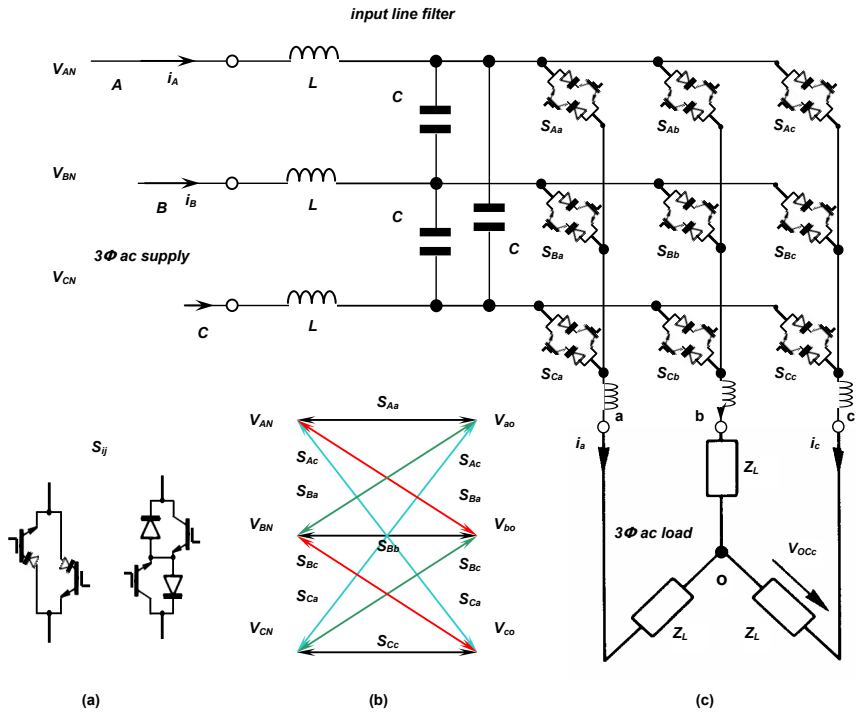

Figure 15.45. Three-phase input to three-phase output matrix converter circuit: (a) bidirectional switches (a) reverse blocking igbts conventional igbts; (b) switching matrix; and (c) three-phase ac supply to three-phase ac load.

With the balanced star load shown in figure 15.44c, the load neutral voltage v_o is given by

$$v_o = \frac{1}{3}(v_a + v_b + v_c) \quad (15.128)$$

The line-to-neutral and line-to-line voltages are the same as those applicable to svm (space voltage modulation, Chapter 17.1.3vii), namely

$$\begin{pmatrix} v_{ao} \\ v_{bo} \\ v_{co} \end{pmatrix} = \frac{1}{6} \begin{pmatrix} 2 & -1 & -1 \\ -1 & 2 & -1 \\ -1 & -1 & 2 \end{pmatrix} \begin{pmatrix} v_a \\ v_b \\ v_c \end{pmatrix} \quad (V) \quad (15.129)$$

from which

$$\begin{pmatrix} v_{ab} \\ v_{bc} \\ v_{ca} \end{pmatrix} = \frac{1}{\sqrt{2}} \begin{pmatrix} 1 & -1 & -1 \\ 0 & 1 & 0 \\ -1 & 0 & 1 \end{pmatrix} \begin{pmatrix} v_a \\ v_b \\ v_c \end{pmatrix} \quad (V) \quad (15.130)$$

Similarly the relationship between the input line currents (i_A, i_B, i_C) and the output currents (i_a, i_b, i_c) is determined by the states of the nine bidirectional switches (S_{ij}), according to

$$\begin{pmatrix} i_A \\ i_B \\ i_C \end{pmatrix} = \begin{pmatrix} S_{Aa} & S_{Ba} & S_{Ca} \\ S_{Ab} & S_{Bb} & S_{Cb} \\ S_{Ac} & S_{Bc} & S_{Cc} \end{pmatrix} \begin{pmatrix} i_a \\ i_b \\ i_c \end{pmatrix} \quad (A) \quad I_{in} = S^T I_{out} \quad (15.131)$$

where the switches S_{ij} are constrained such that no two or three switches short between the input lines or cause discontinuous output current. Discontinuous output current must not occur since no natural default current freewheel paths exist. The input short circuit constraint is complied with by ensuring that only one switch in each row of the 3×3 matrix in equation (15.126) (hence row in equation

(15.131) is on at any time, viz., equation (15.127), while continuous load current in equation (15.131) (hence column in equation (15.126)) is ensured by Kirchoff's current law, that is

$$\sum_{j=1}^3 S_{ij} \geq 1 \quad \text{for at least any two } i \quad (15.132)$$

More than one switch on in a column implies that an input phase is parallel feeding more than one output phase, which is allowable.

If each switch S_{ij} is modulated $m(t)$ (usually sinusoidally in time), the low frequency relationships between the input and output currents and voltages are given by (M is the low frequency transfer matrix)

$$\begin{pmatrix} v_a \\ v_b \\ v_c \end{pmatrix} = \begin{pmatrix} m_{Aa}(t) & m_{Ba}(t) & m_{Ca}(t) \\ m_{Ab}(t) & m_{Bb}(t) & m_{Cb}(t) \\ m_{Ac}(t) & m_{Bc}(t) & m_{Cc}(t) \end{pmatrix} \begin{pmatrix} v_A \\ v_B \\ v_C \end{pmatrix} \quad (V) \quad \text{or } V_{out} = M(t) v_i \quad (15.133)$$

$$\begin{pmatrix} i_A \\ i_B \\ i_C \end{pmatrix} = \begin{pmatrix} m_{Aa}(t) & m_{Ba}(t) & m_{Ca}(t) \\ m_{Ab}(t) & m_{Bb}(t) & m_{Cb}(t) \\ m_{Ac}(t) & m_{Bc}(t) & m_{Cc}(t) \end{pmatrix}^T \begin{pmatrix} i_a \\ i_b \\ i_c \end{pmatrix} \quad (A) \quad \text{or } I_{in} = M(t)^T i_o \quad (15.134)$$

Thus given Kirchoff's voltage and current law constraints, not all the 512 (2^9) states for nine switches can be used, and only 27 states, in three groups as summarized in Table 15.2, of the switch matrix can be utilised.

- The first group, of six combinations, allows each output phase to be connected to a different input phase.
- The second group (with 3 subgroups, each with 6 combinations), of $3 \times 6 = 18$ combinations, is when two output phases connect to the same input phase (two output phases shorted).
- The third group, of three combinations, is when all the output line voltages are zero, shorted.

For sinusoidal input phase voltages of frequency ω_i and maximum voltage V_{imax}

$$v_i = \begin{pmatrix} v_A \\ v_B \\ v_C \end{pmatrix} = V_{imax} \begin{pmatrix} \cos \omega_i t \\ \cos \omega_i t - 120^\circ \\ \cos \omega_i t + 120^\circ \end{pmatrix} \quad (15.135)$$

If sinusoidal output line to line voltages are generated at frequency ω_o and relative displacement ϕ_o , then, neglecting non-fundamental components

$$v_o = \begin{pmatrix} v_{ab} \\ v_{bc} \\ v_{ca} \end{pmatrix} = \sqrt{3} V_{o\max} \begin{pmatrix} \cos \omega_o t - \phi_o + 30^\circ \\ \cos \omega_o t - \phi_o + 30^\circ - 120^\circ \\ \cos \omega_o t - \phi_o + 30^\circ + 120^\circ \end{pmatrix} \quad (15.136)$$

The instantaneous relationship between the input phase voltages and output line voltages is

$$\begin{aligned} v_o &= V_i T_{ph-L} \\ v_o &= v_i m \begin{pmatrix} \cos \omega_o t - \phi_o + 30^\circ \\ \cos \omega_o t - \phi_o + 30^\circ - 120^\circ \\ \cos \omega_o t - \phi_o + 30^\circ + 120^\circ \end{pmatrix} \begin{pmatrix} \cos \omega_i t \\ \cos \omega_i t - 120^\circ \\ \cos \omega_i t + 120^\circ \end{pmatrix}^T \\ &= V_{imax} m \begin{pmatrix} \cos \omega_o t - \phi_o + 30^\circ \\ \cos \omega_o t - \phi_o + 30^\circ - 120^\circ \\ \cos \omega_o t - \phi_o + 30^\circ + 120^\circ \end{pmatrix} \times \frac{3}{2} \cos \phi_i \\ &= \sqrt{3} V_{o\max} \begin{pmatrix} \cos \omega_o t - \phi_o + 30^\circ \\ \cos \omega_o t - \phi_o + 30^\circ - 120^\circ \\ \cos \omega_o t - \phi_o + 30^\circ + 120^\circ \end{pmatrix} \end{aligned} \quad (15.137)$$

where m = modulation index, ϕ_i = input displacement factor, and T = instantaneous transfer matrix.

By equating co-efficients in equation (15.137), the magnitude of the output line to line voltage, in terms of the input phase voltage magnitude is given by

$$V_{o\max} = \frac{1}{\sqrt{2}} \sqrt{3} \times m \times V_{imax} \cos \phi_i \quad (15.138)$$

Table 15.2: Three-phase voltage to three-phase current matrix converter switch combinations

Group	S _{Aa} S _{Ab} S _{Ac}	S _{Ba} S _{Bb} S _{Bc}	S _{Ca} S _{Cb} S _{Cc}	A B C	V _{ab} V _{bc} V _{ca}	i _a i _b i _c
I	1 0 0	0 1 0	0 0 1	A B C	V _{AB} V _{BC} V _{CA}	i _a i _b i _c
I	1 0 0	0 0 1	0 1 0	A C B	-V _{AB} -V _{CA} -V _{BC}	i _b i _a i _c
I	0 1 0	1 0 0	0 0 1	B A C	-V _{AB} -V _{CA} -V _{BC}	i _b i _a i _c
I	0 1 0	0 0 1	1 0 0	B C A	V _{BC} V _{CA} V _{AB}	i _c i _a i _b
I	0 0 1	1 0 0	0 1 0	C A B	V _{CA} V _{AB} V _{BC}	i _b i _c i _a
I	0 0 1	0 1 0	1 0 0	C B A	-V _{BC} -V _{AB} -V _{CA}	i _c i _b i _a
II-A	1 0 0	0 0 1	0 0 1	A C C	-V _{CA} 0 V _{CA}	i _a 0 -i _a
II-A	0 1 0	0 0 1	0 0 1	B C C	V _{BC} 0 -V _{BC}	0 -i _a i _a
II-A	0 1 0	1 0 0	1 0 0	B A A	-V _{AB} 0 -V _{AB}	i _a i _a 0
II-A	0 0 1	1 0 0	1 0 0	C A A	V _{CA} 0 -V _{CA}	-i _a 0 i _a
II-A	0 0 1	0 1 0	0 1 0	C B B	-V _{BC} 0 V _{BC}	0 -i _a i _a
II-A	1 0 0	0 1 0	0 1 0	A B B	V _{AB} 0 -V _{AB}	i _a -i _a 0
II-B	0 0 1	1 0 0	0 0 1	C A C	-V _{CA} -V _{CA} 0	i _b 0 -i _b
II-B	0 0 1	0 1 0	0 0 1	C B C	-V _{BC} V _{BC} 0	0 i _b -i _b
II-B	1 0 0	0 1 0	1 0 0	A B C	V _{AB} -V _{AB} 0	-i _b i _b 0
II-B	1 0 0	0 0 1	1 0 0	A C A	-V _{CA} V _{CA} 0	-i _a 0 i _b
II-B	0 1 0	0 0 1	0 1 0	B C B	V _{BC} -V _{BC} 0	0 -i _b i _b
II-B	0 1 0	1 0 0	0 1 0	B A B	-V _{AB} V _{AB} 0	i _a -i _b 0
II-C	0 0 1	0 0 1	1 0 0	C C A	0 V _{CA} -V _{CA}	i _c 0 -i _c
II-C	0 0 1	0 0 1	0 1 0	C C B	0 -V _{BC} V _{BC}	0 i _c -i _c
II-C	1 0 0	1 0 0	0 1 0	A A B	0 V _{AB} -V _{AB}	-i _c i _c 0
II-C	1 0 0	1 0 0	0 0 1	A A C	0 -V _{CA} V _{CA}	-i _c 0 i _c
II-C	0 1 0	0 1 0	0 0 1	B B C	0 V _{BC} -V _{BC}	0 -i _c i _c
II-C	0 1 0	0 1 0	1 0 0	B B A	0 -V _{AB} V _{AB}	i _c -i _c 0
III	1 0 0	1 0 0	1 0 0	A B C	0 0 0	0 0 0
III	0 1 0	0 1 0	0 1 0	A B C	0 0 0	0 0 0
III	0 0 1	0 0 1	0 0 1	A B C	0 0 0	0 0 0

The maximum voltage gain, when $m = 1$ and unity input displacement pf , $\cos\phi_i = 1$, the ratio of the peak fundamental ac output voltage to the peak ac input voltage is $\frac{1}{2}\sqrt{3} = 0.866$. Above this level, called over-modulation, distortion of the input current occurs.

Expressions similar to equations (15.135) to (15.138) are applicable to the input and output currents. The output current is

$$i_o = \begin{pmatrix} i_{ab} \\ i_{bc} \\ i_{ca} \end{pmatrix} = \frac{I_{o\max}}{\sqrt{3}} \begin{pmatrix} \cos\omega_o t - \phi_o + 30^\circ - \phi_L \\ \cos\omega_o t - \phi_o + 30^\circ - 120^\circ - \phi_L \\ \cos\omega_o t - \phi_o + 30^\circ + 120^\circ - \phi_L \end{pmatrix} \quad (15.139)$$

where $\cos\phi_L$ is the load power factor and $I_{o\max}$ is the amplitude of the output line current.

The relationship between the input and output line currents is

$$i_i = \begin{pmatrix} i_A \\ i_B \\ i_C \end{pmatrix} = T_{ph-L}^T i_o \quad (15.140)$$

$$= \frac{1}{2}\sqrt{3} I_{o\max} \cos\phi_L \begin{pmatrix} \cos\omega_o t - \phi_i \\ \cos\omega_o t - \phi_i - 120^\circ \\ \cos\omega_o t - \phi_i + 120^\circ \end{pmatrix}$$

By equating co-efficients, the relationship between the input and output current magnitudes is

$$I_{i\max} = \frac{1}{2}\sqrt{3} I_{o\max} \cos\phi_L \quad (15.141)$$

Additionally the input power must equal the output power, that is

$$P_i = \sqrt{3} V_i i_i \cos\phi_i = \sqrt{3} V_o i_o \cos\phi_o = P_o \quad (15.142)$$

Since the switches are bidirectional and fully controlled, power flow can be bidirectional. Control involves the use of a modulation index, $0 \leq m \leq 1$, that varies sinusoidally.

Modulation strategies

If the input currents and output voltages are to be sinusoidal, from equations (15.140) and (15.137), respectively, the voltage gain $q = V_{o\max}/V_{i\max}$ between the output and input voltages is given by

$$M_1 = \frac{1}{3} \begin{pmatrix} 1 + 2q \cos\omega_m t & 1 + 2q \cos\omega_m t - 120^\circ & 1 + 2q \cos\omega_m t + 120^\circ \\ 1 + 2q \cos\omega_m t + 120^\circ & 1 + 2q \cos\omega_m t & 1 + 2q \cos\omega_m t - 120^\circ \\ 1 + 2q \cos\omega_m t - 120^\circ & 1 + 2q \cos\omega_m t + 120^\circ & 1 + 2q \cos\omega_m t \end{pmatrix} \quad (15.143)$$

where $\omega_m = \omega_o - \omega_i$ such that $\phi_i = \phi_o$ and

$$M_2 = \frac{1}{3} \begin{pmatrix} 1 + 2q \cos\omega_m t & 1 + 2q \cos\omega_m t - 120^\circ & 1 + 2q \cos\omega_m t + 120^\circ \\ 1 + 2q \cos\omega_m t - 120^\circ & 1 + 2q \cos\omega_m t + 120^\circ & 1 + 2q \cos\omega_m t \\ 1 + 2q \cos\omega_m t + 120^\circ & 1 + 2q \cos\omega_m t & 1 + 2q \cos\omega_m t - 120^\circ \end{pmatrix} \quad (15.144)$$

where $\omega_m = -(\omega_o - \omega_i)$ such that $\phi_i = -\phi_o$

The solution $\phi_i = \phi_o$ gives the same phase displacement at the input and output ports whereas the solution $\phi_i = -\phi_o$ gives the reversed phase displacement. Combining both solutions provides for input displacement factor control. The maximum voltage ratio is when $q = \frac{1}{2}$.

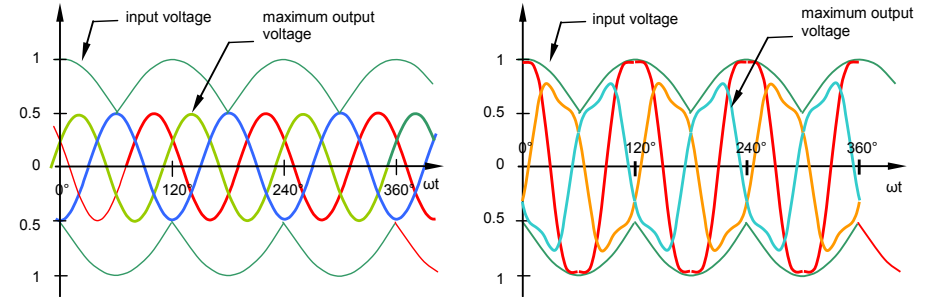

Figure 15.46. Three-phase input voltages and three-phase output voltages showing: (a) maximum output magnitude of 0.5 pu and (b) output voltage increased to 0.866 pu with triplen injection.

As with standard sinusoidal PWM, by adding triplens (3^{rd} harmonics from the input and output) q can be increased from $\frac{1}{2}$ to $\frac{1}{2}\sqrt{3} = 0.866$, as illustrated in part b of figure 15.45.

$$v_o = qV_{i\max} \begin{pmatrix} \cos\omega_o t & -\frac{1}{6} \cos 3\omega_o t + \frac{1}{2\sqrt{3}} \cos 3\omega_o t \\ \cos(\omega_o t - 120^\circ) - \frac{1}{6} \cos 3\omega_o t + \frac{1}{2\sqrt{3}} \cos 3\omega_o t \\ \cos(\omega_o t + 120^\circ) - \frac{1}{6} \cos 3\omega_o t + \frac{1}{2\sqrt{3}} \cos 3\omega_o t \end{pmatrix} \quad (15.145)$$

The switching sequence must comply with overlap of current source paths and under lap of voltage source paths. Switch commutation involves a number of delay steps, depending on the current direction, as in the four step semi-soft sequence shown in figure 15.47x. Problems arise at low current levels in discerning the current direction, hence conducting switch. This issue is avoided if voltage detection is used to determine the conducting switch, whence the number commutation step can be reduced to two.

Since no intermediate energy storage stage is involved, such as a dc link, this so called total silicon solution to ac to ac conversion provides no ride-through, thus is not well suited to ups application. The advantage of the matrix converter over a dc link approach to ac to ac conversion lies not in the fact that a dc link capacitor is not required. Given the matrix converter requires an input L-C filter, capacitor size and cost requirements are similar. The key feature of the matrix converter is that the capacitor voltage

requirement is ac. For a given temperature, ripple current, etc., the lifetime of an ac capacitor is significantly longer than a dc voltage electrolytic capacitor, as is required for a dc link. The use of oil impregnated paper bipolar capacitors to improve dc-link inverter reliability, significantly increases capacitor volume and cost for a given capacitance and voltage. The matrix converter offers four-quadrant operation, having inherent regenerative ability.

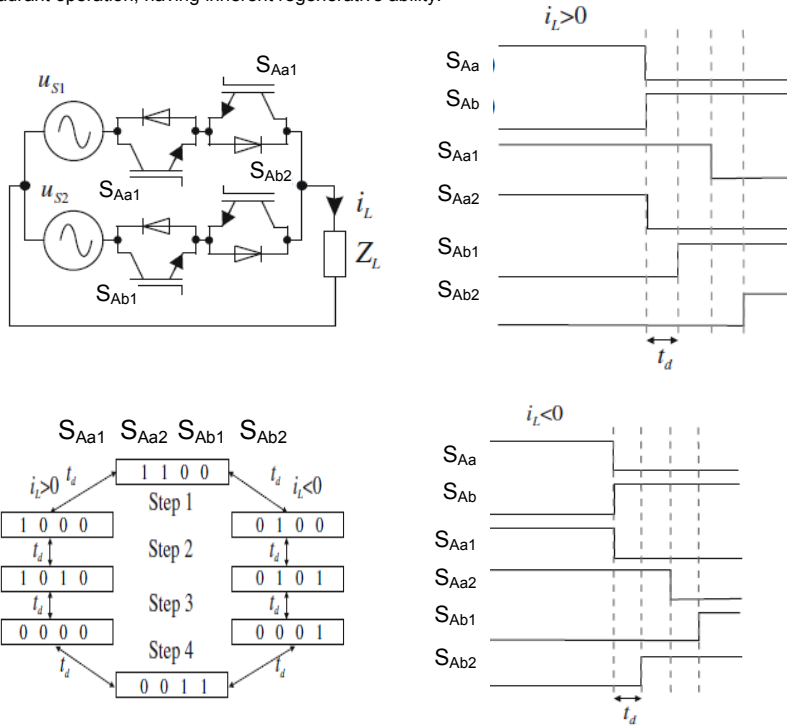

Figure 15.47x. Four step commutation process, depending on load current direction..

Limitations of the voltage source matrix converter, hampering its envisaged exploitation are

- The ac output voltage is restricted to 86.6% of the ac input voltage (without distortion)
- (A voltage gain of 1.155 is possible with duty cycle SVM, with input/output distortion)
- The need for a capacitive over voltage 3Φ clamping circuit due commutation spikes, as per figure 15.47
- Inter dependence between the input and output voltage and current harmonics
- The need for reverse blocking bidirectional current and voltage switches
- Minimal ride-through capability
- Switch commutation requirement complexity
- Trapped energy at converter shut down

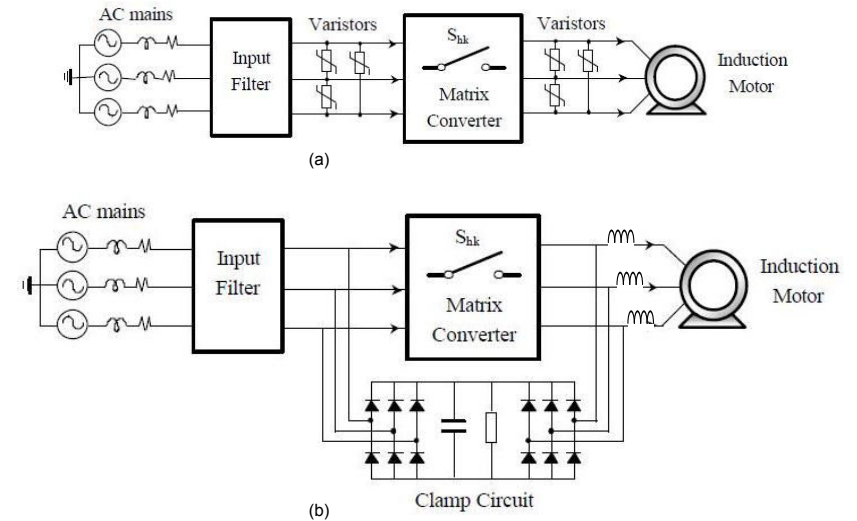

Figure 15.47. Two protection arrangements for the matrix converter: (a) varistor clamping and (b) common rectifiers with capacitor discharge.

15.7.1 High frequency resonant dc to ac matrix converter

A combination of integral cycle control with a high-frequency single-phase to three-phase matrix converter is shown in figure 15.48. High frequency ac is produced by a H-bridge parallel resonant voltage converter, which is transformer coupled to the matrix converter. A key feature is that both the H-bridge and matrix converter switches, can be soft-switched for low switching losses. Figure 15.49 shows the output voltage waveforms constituted from half-sine resonant voltage pulse components.

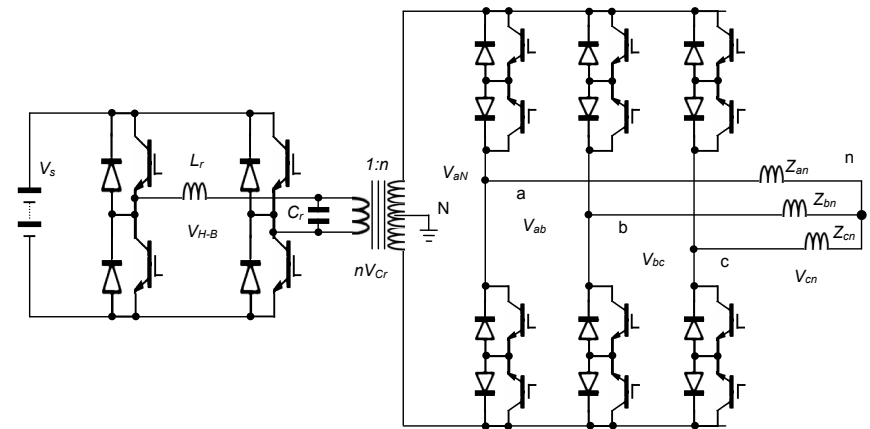

Figure 15.48. Twelve switch high frequency ac to ac converter.

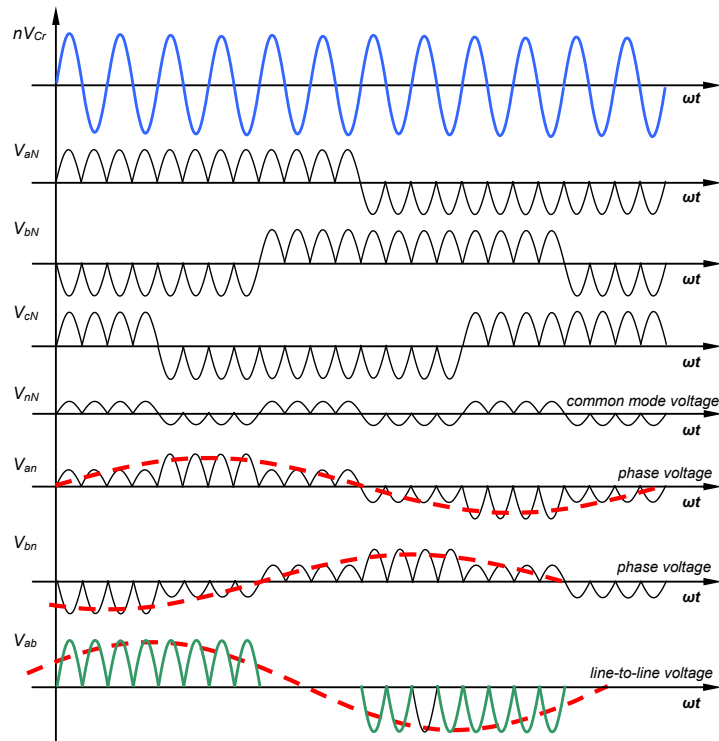

Figure 15.49. Quasi-square generated voltages of the twelve switch high frequency ac to ac converter.

15.8 ac to ac conversion with a dc link

Back to back three phase converters, with a dc link, as in figure 15.50, offer input and output independence of both currents and voltages with unity power factor and sinusoidal input current. Bidirectional power flow is inherent. The voltage dc link version in figure 15.50a has two drawbacks. First the input ac to dc converter is based on the boost converter hence the link voltage cannot fall below the ac rectified level. Although offering output voltages that can exceed the ac input voltage, uncontrolled inrush current flows at start up, so hardware soft-start circuitry must be incorporated. Such resistor/contacter circuitry can form part of the ac input connection/protection circuitry on two phases or can be a single resistor/contacter on the dc link, before the link capacitor. Since the link current is dc, the dc link contact should be opened and closed under zero current conditions. The second drawback is the need for a dc link capacitor, the capacitance of which should be minimised so as to be non-electrolytic, for an extended lifetime warranty.

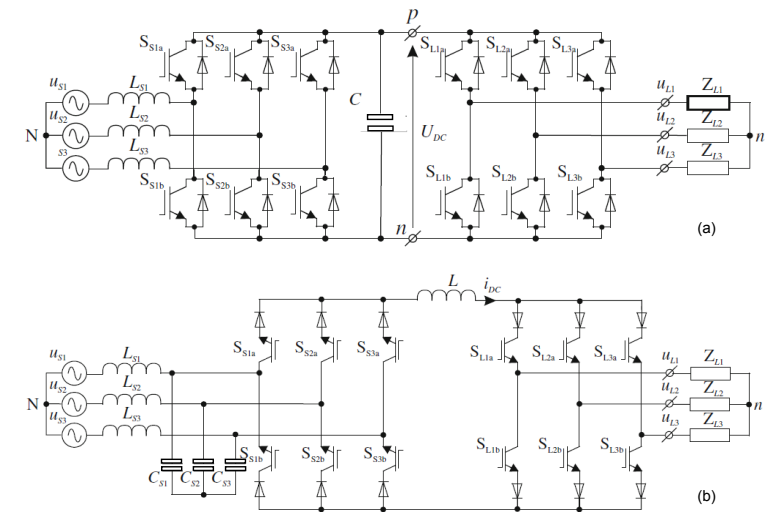

Figure 15.50. Back to back three-phase converters with a: (a) voltage and (b) current dc link.

15.9 Power Quality: load efficiency and supply current power factor

One characteristic of ac regulators is non-sinusoidal load current, hence supply current as illustrated in figure 15.1b. Complication therefore exists in defining the supply current power factor and the harmonics in the load current may detract from the load efficiency. For example, with a single-phase motor, current components other than the fundamental detract from the fundamental torque and increase motor heating, noise, and vibration. To illustrate the procedure for determining load efficiency and supply power factor, consider the circuit and waveforms in figure 15.1.

15.9.1 Load waveforms

The load voltage waveform is constituted from the sinusoidal supply voltage v and is defined by

$$v_o(\omega t) = \sqrt{2}V \sin \omega t \quad (\text{V})$$

$$\alpha \leq \omega t \leq \beta \quad (15.146)$$

$$\pi + \alpha \leq \omega t \leq \pi + \beta$$

and $v_o = 0$ elsewhere.

Fourier analysis of v_o yields the load voltage Fourier coefficients v_{an} and v_{bn} such that

$$v_o(\omega t) = \sum \{ v_{an} \cos n\omega t + v_{bn} \sin n\omega t \} \quad (\text{V}) \quad (15.147)$$

for all values of n .

The load current can be evaluated by solving

$$Ri_o + L \frac{di_o}{dt} = \sqrt{2}V \sin \omega t \quad (\text{V}) \quad (15.148)$$

over the appropriate bounds and initial conditions. From Fourier analysis of the load current i_o , the load current coefficients i_{an} and i_{bn} can be derived.

Derivation of the current waveform Fourier coefficients may prove complicated because of the difficulty of integrating an expression involving equation (15.2), the load current. An alternative and possibly simpler approach is to use superposition and the fact that each load Fourier voltage component produces a load current component at the associated frequency but displaced because of the load impedance at that frequency. That is

$$i_{an} = \frac{v_{an}}{R} \cos \phi_n \quad (\text{A})$$

$$i_{bn} = \frac{v_{bn}}{R} \cos \phi_n \quad (\text{A}) \quad (15.149)$$

$$\text{where } \phi_n = \tan^{-1} n\omega L / R$$

The load current i_o is given by

$$i_o(\omega t) = \sum_{\forall n} \{ i_{an} \cos(n\omega t - \phi_n) + i_{bn} \sin(n\omega t - \phi_n) \} \quad (\text{A}) \quad (15.150)$$

The load efficiency, η , which is related to the power dissipated in the resistive component R of the load, is defined by

$$\eta = \frac{\text{fundamental active power}}{\text{total active power}}$$

$$= \frac{1/2 (i_{a1}^2 R + i_{b1}^2 R)}{1/2 \sum_{\forall n} (i_{an}^2 R + i_{bn}^2 R)} = \frac{i_{a1}^2 + i_{b1}^2}{\sum_{\forall n} (i_{an}^2 + i_{bn}^2)} \quad (15.151)$$

In general, the total load power is $\sum_{\forall n} v_{n \text{ rms}} \times i_{n \text{ rms}} \times \cos \phi_n$.

15.9.2 Supply waveforms

Linear load:

For sinusoidal single and three-phase ac supply voltages feeding a linear load, the load power and apparent power are given by

$$P = V_s I_s \cos \phi \quad S = V_s I_s$$

$$P = \sqrt{3} V_{LL} I_s \cos \phi \quad S = V_{LL} I_s \quad (15.152)$$

and the supply power factor is

$$\cos \phi = \frac{P}{S} \quad (15.153)$$

Non-linear loads (e.g. rectification):

i. The supply distortion factor μ , displacement factor $\cos \psi$, and power factor λ give an indication of the adverse effects that a non-sinusoidal load current has on the supply as a result of SCR phase control. In the circuit of figure 15.1a, the load and supply currents are the same and given by equation (15.2). The supply current Fourier coefficients i_{san} and i_{sbn} are the same as for the load current Fourier coefficients i_{an} and i_{bn} respectively, as previously defined.

The total supply (input) power factor λ can be defined as

$$pf = \lambda = \frac{\text{real power}}{\text{apparent power}} = \frac{\text{total mean input power}}{\text{total rms input VA}} \quad (15.154)$$

$$= \frac{V_{1 \text{ rms}} i_{1 \text{ rms}} \cos \psi_1}{V_{\text{rms}} I_{\text{rms}}} = \frac{1/\sqrt{2} \sqrt{V_{sa1}^2 + V_{sb1}^2} \times 1/\sqrt{2} \sqrt{i_{sa1}^2 + i_{sb1}^2} \times \cos \psi_1}{V \times 1/\sqrt{2} \sqrt{i_{a1}^2 + i_{b1}^2}}$$

The supply voltage is sinusoidal hence supply power is not associated with the harmonic non-fundamental currents.

$$\lambda = \frac{V \sqrt{1/2 (i_{sa1}^2 + i_{sb1}^2)} \cos \psi_1}{V I_{\text{rms}}} \quad (15.155)$$

$$= \frac{\sqrt{1/2 (i_{sa1}^2 + i_{sb1}^2)} \cos \psi_1}{I_{\text{rms}}} = \frac{i_{s1}}{I_{\text{rms}}} \times \cos \psi_1 = DF_{11} \times DPF$$

where $\cos \psi$, termed the displacement power factor, DPF , is the fundamental power factor defined as

$$\cos \psi_1 = \cos(-\tan^{-1} i_{sb1}/i_{sa1}) \quad (15.156)$$

Equating with equation (15.155), the total supply power factor is defined as

$$\lambda = \mu \cos \psi_1 \quad 0 \leq \lambda \leq 1 \quad (15.157)$$

The supply current distortion factor μ is the ratio of fundamental rms current to total rms current $i_{s \text{ rms}}$, that is

$$\mu = \frac{\sqrt{1/2 (i_{sa1}^2 + i_{sb1}^2)}}{i_{\text{rms}}} = \frac{i_{s1}}{I_{\text{rms}}} \quad (15.158)$$

ii. (a) The supply fundamental harmonic factor ρ_F is defined as

$$\rho_F = \frac{\text{total harmonic (non - fundamental) rms current (or voltage)}}{\text{fundamental rms current (or voltage)}} \quad (15.159)$$

$$= \frac{I_h}{i_{s1}} = \frac{I_h}{\sqrt{i_{sa1}^2 + i_{sb1}^2}} = \frac{\sqrt{I_{\text{rms}}^2 - i_{s1}^2}}{\sqrt{i_{sa1}^2 + i_{sb1}^2}} = \sqrt{\frac{1}{\mu^2} - 1}$$

where I_h is the total harmonic (non-fundamental) current (assuming no dc component)

$$I_h = \sqrt{I_{\text{rms}}^2 - i_{s1}^2} \quad (15.160)$$

$$= \sqrt{\sum_{n=1}^{\infty} I_{n \text{ rms}}^2} = \frac{1}{\sqrt{2}} \sqrt{\sum_{n=1}^{\infty} (i_{san}^2 + i_{sbn}^2)}$$

The general relationships between the various current forms can be summarised as

$$I_{\text{rms}} = \sqrt{I_{\text{dc}}^2 + I_{1 \text{ rms}}^2 + I_{2 \text{ rms}}^2 + I_{3 \text{ rms}}^2 + \dots} \quad (15.161)$$

$$= \sqrt{I_{\text{dc}}^2 + I_{1 \text{ rms}}^2 + I_h^2} \quad \text{or} \quad = \sqrt{I_{\text{dc}}^2 + I_{\text{ac}}^2}$$

(b) Alternatively, the supply total rms harmonic factor ρ_{RMS} is defined as:

$$\rho_{\text{RMS}} = \frac{\text{total harmonic (non - fundamental) rms current (or voltage)}}{\text{total rms current (or voltage)}} \quad (15.162)$$

$$= \frac{I_h}{i_{\text{rms}}} = \sqrt{1 - \frac{i_{s1}^2}{I_{\text{rms}}^2}} = \sqrt{1 - \mu^2}$$

The total harmonic distortion, THD is defined as

$$THD = \frac{I_{\text{distortion}}}{i_{s1}} = \frac{I_h}{i_{s1}} = \frac{\sqrt{I_{\text{rms}}^2 - i_{s1}^2}}{i_{s1}} = \sqrt{\left(\frac{\cos \psi_1}{pf} \right)^2 - 1} \quad (15.163)$$

Thus the power factor pf and displacement power factor DPF are related by

$$pf = \frac{\cos \psi_1}{\sqrt{1 + THD^2}} = \frac{DPF}{\sqrt{1 + THD^2}} \quad (15.164)$$

- iii. The supply crest factor δ is defined as the ratio of peak supply current \hat{i}_s to the total rms current:

$$\delta = \hat{i}_s / I_{rms} \quad (15.165)$$

- iv. The energy conversion factor ν is defined by

$$\begin{aligned} \nu &= \frac{\text{fundamental output power}}{\text{fundamental input power}} \\ &= \frac{\frac{1}{\sqrt{2}} \sqrt{V_{o1}^2 + V_{b1}^2} \times \frac{1}{\sqrt{2}} \sqrt{I_{o1}^2 + I_{b1}^2} \times \cos \phi_1}{V \times \frac{1}{\sqrt{2}} \sqrt{I_{so1}^2 + I_{sb1}^2} \times \cos \psi_1} \end{aligned} \quad (15.166)$$

Example 15.7: Power quality - load efficiency

If a purely resistive load R is fed with a voltage

$$v_o = \sqrt{2}V \sin \omega t + \frac{\sqrt{2}V}{3} \sin 3\omega t$$

what is the fundamental load efficiency?

Solution

The load current is given by

$$i_o = v_o/R = \frac{\sqrt{2}V}{R} (\sin \omega t + \frac{1}{3} \sin 3\omega t)$$

The load efficiency is given by equation (15.151), that is

$$\begin{aligned} \eta &= \frac{\left(\frac{\sqrt{2}V}{R}\right)^2 R}{\left(\frac{\sqrt{2}V}{R}\right)^2 R + \left(\frac{\sqrt{2}V}{3R}\right)^2 R} \\ &= \frac{1}{1 + \frac{1}{9}} = 0.90 \end{aligned}$$

The introduced third harmonic component decreases the load efficiency by 10%.

Example 15.8: Power quality – squarewave distortion

What is the total harmonic distortion, THD, in a squarewave approximation to its fundamental component?

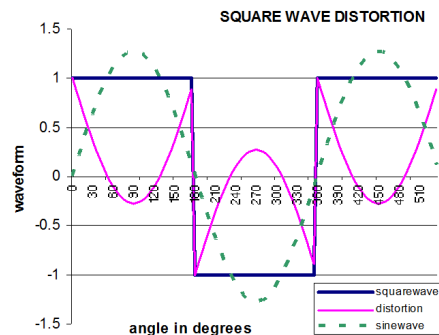

Figure 15.50. Non-fundamental component of a squarewave.

Solution

A pu square-wave has an rms value of 1pu while its pu square-wave Fourier series is given by

$$V_{pu} = \frac{4}{\pi} \left(\sin \omega t + \frac{1}{3} \sin 3\omega t + \frac{1}{5} \sin 5\omega t + \frac{1}{7} \sin 7\omega t + \dots \right)$$

The THD is given by

$$THD = \frac{V_{distortion}}{V_{fundamental}} = \frac{\sqrt{V_{rms}^2 - V_{fundamental,rms}^2}}{V_{fundamental,rms}} = \frac{\sqrt{2 \times 1pu - \left(\frac{4}{\pi}\right)^2}}{\frac{4}{\pi}} = 48.34\%$$

Example 15.9: Power quality - sinusoidal source and constant current load

A half-wave rectifier with a load freewheel diode as shown in figure 13.6 has a 10A constant current load, I_o . If rectifier circuit is supplied from the ac mains with voltage $v(\omega t) = \sqrt{2} 230 \times \sin 2\pi 50t$ determine:

- the supply apparent power and average load power
- the total supply power factor, λ , hence distortion, μ , and displacement factors
- the average and rms current rating of each diode and diode reverse voltage requirements

Solution

The rms supply voltage is 230V, at 50Hz. The supply current is a 10ms, 10A current block occurring every 20ms. The rms supply current is therefore $10/\sqrt{2} = 7.07A$.

- i. The supply apparent power is

$$\begin{aligned} S &= V_{rms} I_{rms} \\ &= 230V \times 7.07A = 1626.1VAr \end{aligned}$$

The average load voltage is that for half wave rectification, viz.,

$$V_o = \frac{\sqrt{2}V}{\pi} = 103.5V$$

The average load power, which must be equal to the input power from the 50Hz source, is

$$P_o = P_{in} = V_o I_o = 103.5V \times 10A = 1035W$$

The fundamental of a square wave, with a dc offset of half the magnitude is

$$I_{1,rms} = \frac{1}{\sqrt{2}} \hat{I}_1 = \frac{1}{\sqrt{2}} \times \frac{2}{\pi} \times 10A = 4.50A$$

which is in phase with the ac supply, that is $\cos \phi_{50Hz} = 1$.

Alternately, the load power, hence input power, which is at the supply voltage frequency of 50Hz, can be confirmed by

$$\begin{aligned} P_{in} &= V_{rms} I_{rms} \cos \phi_{50Hz} \\ &= 230V \times 7.07A \times 1 = 1035W \end{aligned}$$

- ii. The power factor is

$$pf = \lambda = \frac{P_{in}}{S} = \frac{1035W}{1626.1VAr} = 0.64$$

The current distortion factor is

$$DF = \mu = \frac{I_{1,rms}}{I_{rms}} = \frac{4.50A}{7.07A} = 0.64$$

which, since the supply is single frequency sinusoidal, confirms that the displacement factor for the fundamental current is

$$\cos \psi_1 = \frac{\lambda}{\mu} = \frac{0.64}{0.64} = 1 = \cos \phi_{50Hz}$$

that is $\phi_{50Hz} = 0^\circ$

- iii. The average and rms current ratings of both the rectifying diode and the freewheel diode are the same, viz.,

$$\bar{I}_D = \frac{I_o}{2} = \frac{10A}{2} = 5A \quad I_{D,rms} = \frac{I_o}{\sqrt{2}} = \frac{10A}{\sqrt{2}} = 7.07A$$

In reverse bias, each diode experiences alternate ac supply peak voltages of $\sqrt{2} 230V = 325.3V$

Example 15.10:**Power quality - sinusoidal source and non-linear load**

An unbalanced single-phase rectifier circuit is supplied from the ac mains with voltage $v(\omega t) = \sqrt{2} 230 \sin 2\pi 50t$. The dominant resultant harmonics in the supply current are

$$i(\omega t) = 10 + 15 \times \sin(\omega t + \frac{1}{6}\pi) + 3 \times \sin(2\omega t + \frac{1}{4}\pi) + 2 \times \sin(4\omega t - \frac{1}{4}\pi)$$

Determine

- the fundamental power factor hence power delivered from the supply
- the total supply power factor, hence distortion factor
- the harmonic current and the ac current
- the total harmonic distortion with respect to the fundamental current and the total rms current
- the current crest factor.

Solution

- i. The power from the supply delivered to the load is only at the supply frequency

$$P_{50\text{Hz}} = V_{s50\text{Hz}} I_{s50\text{Hz}} \cos \phi_{50\text{Hz}} \\ = 230\text{V} \times \frac{15\text{A}}{\sqrt{2}} \times \cos \frac{1}{6}\pi = 2113\text{W}$$

The fundamental power factor $\cos \frac{1}{6}\pi = 0.866$, leading.

- ii. The total supply power factor is

$$pf = \lambda = \frac{P_{50\text{Hz}}}{S} = \frac{V_{s50\text{Hz}} I_{s50\text{Hz}} \times \cos \phi_{50\text{Hz}}}{V_{s50\text{Hz}} \times I_s} = \frac{I_{s50\text{Hz}} \times \cos \phi_{50\text{Hz}}}{I_s} = \mu \cos \psi_1$$

The supply rms current I_s is

$$I_s = \sqrt{10^2 + \left(\frac{15\text{A}}{\sqrt{2}}\right)^2 + \left(\frac{3\text{A}}{\sqrt{2}}\right)^2 + \left(\frac{2\text{A}}{\sqrt{2}}\right)^2} = 14.8\text{A}$$

Hence

$$\lambda = \frac{P_{50\text{Hz}}}{S} = \frac{2113\text{W}}{230\text{V} \times 14.8\text{A}} = 0.62 \\ = \frac{15\text{A}/\sqrt{2}}{14.8\text{A}} \times 0.866 = 0.717 \times 0.866 = \mu \cos \psi_1$$

The total supply power factor λ is 0.62 and the current distortion factor μ is 0.717.

- iii. From equation (15.160) the supply harmonic (non 50Hz) current is

$$I_h = \sqrt{I_{rms}^2 - I_{s1}^2} \\ = \sqrt{14.8^2 - \left(\frac{15}{\sqrt{2}}\right)^2} = 10.3\text{A}$$

and from equation (15.161) the ac supply current (non-dc) is

$$I_{ac} = \sqrt{I_{rms}^2 - I_{dc}^2} \\ = \sqrt{14.8\text{A}^2 - 10\text{A}^2} = 10.9\text{A}$$

- iv. From equations (15.159) and (15.162), total harmonic distortions on the supply current are

$$\rho_F = \frac{\text{total harmonic (non - 50Hz) rms current}}{\text{fundamental rms current}} \\ = I_h / I_{s1} = \sqrt{\frac{1}{\mu^2} - 1} = \sqrt{\frac{1}{0.717^2} - 1} = 0.97$$

and

$$\rho_{RMS} = \frac{\text{total harmonic (50Hz) rms current}}{\text{total rms current}} \\ = I_h / I_{rms} = \sqrt{1 - \mu^2} = \sqrt{1 - 0.717^2} = 0.70$$

- v. The current crest factor is given by equation (15.165), namely $\delta = \hat{i}_s / I_{rms}$. The maximum supply current will be dominated by the dc and 50Hz components thus the maximum will be near $\omega t + \frac{1}{6}\pi = \frac{1}{2}\pi$, $\omega t = \frac{1}{3}\pi$. Iteration around $\omega t = \frac{1}{3}\pi$ gives $\hat{i}_s = 28.85\text{A}$ at $\omega t = 0.83$ rad.

$$\delta = \frac{\hat{i}_s}{I_{rms}} = \frac{28.85\text{A}}{14.8\text{A}} = 1.95$$

Reading list

Hart, D.W., *Introduction to Power Electronics*,
Prentice-Hall, Inc, 1994.

Rombaut, C., *et al.*, *Power Electronic Converters – AC/AC Conversion*,
North Oxford Academic Publishers, 1987.

Problems

- Determine the rms load current for the ac regulator in figure 15.25, with a resistive load R . Consider the delay angle intervals 0 to $\frac{1}{2}\pi$, $\frac{1}{2}\pi$ to $\frac{3}{4}\pi$, and $\frac{3}{4}\pi$ to π .
- The ac regulator in figure 15.25, with a resistive load R has one thyristor replaced by a diode. Show that the rms output voltage is

$$V_{rms} = \left[\frac{1}{2\pi} (2\pi - \alpha + \frac{1}{2} \sin 2\alpha) \right]^{1/2}$$
 while the average output voltage is

$$\bar{V}_o = \frac{\sqrt{2}V}{2\pi} (\cos \alpha - 1)$$
- Plot the load power for a resistive load for the fully controlled and half-controlled three-phase ac regulator, for varying phase delay angle, α . Normalise power with respect to \hat{V}^2 / R .
- For the tap changer in figure 15.15, with a resistive load, calculate the rms output voltage for a phase delay angle α . If $v_2 = 200\text{V}$ ac and $v_1 = 240\text{V}$ ac, calculate the power delivered to a $10\ \Omega$ resistive load at delay angles of $\frac{1}{4}\pi$, $\frac{1}{2}\pi$, and $\frac{3}{4}\pi$. What is the maximum power that can be delivered to the load?
- A 0.01H inductance is added in series with the load in problem 15.4. Determine the load voltage and current waveforms at a firing delay angle of $\frac{1}{2}\pi$. Assuming a 50 Hz supply, what is the minimum delay angle?
- The thyristor T_2 in the single-phase controller in figure 15.1a is replaced by a diode. The supply is 240V ac, 50 Hz and the load is $10\ \Omega$ resistive. For a delay angle of $\alpha = 90^\circ$, determine the
 - rms output voltage
 - supply power factor
 - mean output voltage
 - mean input current.
 [207.84 V; 0.866 lagging; 54 V; 5.4 A]
- The single-phase ac controller in figure 15.6 operating on the 240 V , 50 Hz mains is used to control a $10\ \Omega$ resistive heating load. If the load is supplied repeatedly for 75 cycles and disconnected for 25 cycles, determine the
 - rms load voltage,
 - input power factor, λ , and
 - the rms thyristor current.

- 15.8 The ac controller in problem 15.3 delivers 2.88kW. Determine the duty cycle, m/N , and the input power factor, λ .
- 15.9 A single-phase ac controller with a 240Vac 50Hz voltage source supplies an R - L load of $R=40\Omega$ and $L=50\text{mH}$. If the thyristor gate delay angle is $\alpha = 30^\circ$, determine:
- an expression for the load current
 - the rms load current
 - the rms and average current in the thyristors
 - the power absorbed by the load
 - sketch the load, supply and thyristor voltages and currents.
- 15.10. A single-phase thyristor ac controller is to delivery 500W to an R - L load of $R=25\Omega$ and $L=50\text{mH}$. If the ac supply voltage is 240V ac at 50Hz, determine
- thyristor rms and average current
 - maximum voltages across the thyristors.
- 15.11. The thyristor T_2 in the single-phase controller in figure 15.1a is replaced by a diode. The supply is 240V ac, 50 Hz and the load is 10Ω resistive. Determine the
- an expression for the rms load voltage in terms of α
 - the range of rms voltage across the load resistor.

blank