

CHAPTER 14

Naturally Commutating AC to DC Converters ***- Controlled Rectifiers***

The converter circuits considered in this chapter have in common an ac voltage supply input and a dc load output. The function of the converter circuit is to convert the ac source energy into controllable dc load power, mainly for highly inductive loads. Turn-off of converter semiconductor devices is brought about by the ac supply voltage reversal, a process called *line commutation* or *natural commutation*.

Converter circuits employing only diodes are termed *uncontrolled* (or *rectifiers*) while the incorporation of only thyristors results in a (fully) *controlled converter*. The functional difference is that the diode conducts when forward-biased whereas the turn-on of the forward-biased thyristor can be controlled from its gate. An uncontrolled converter provides a fixed output voltage for a given ac supply and load.

Converters employing a combination of both diodes and thyristors are generally termed *half-controlled* (or *semi-controlled*). Both fully controlled and half-controlled converters allow an adjustable output voltage by controlling the phase angle at which the forward biased thyristors are turned on. The polarity of the output (load) voltage of a fully controlled converter can reverse (but the current flow direction is not reversible), allowing power flow into the supply, a process called *inversion*. Thus a fully controlled converter can be described as a *bidirectional converter* as it facilitates power flow in either direction.

The half-controlled converter, as well as the uncontrolled converter, contains diodes which prevent the output voltage from going negative. Such converters only allow power flow from the ac supply to the dc load, termed *rectification*, and can therefore be described as *unidirectional converters*.

Although all these converter types provide a dc output, they differ in characteristics such as output ripple and mean voltage as well as efficiency and ac supply harmonics.

An important converter characteristic is that of pulse number, which is defined as the repetition rate in the direct output voltage during one complete cycle of the input ac supply.

A useful way to judge the quality of the required dc output, is by the contribution of its superimposed ac harmonics. The harmonic or ripple factor RF is defined by

$$RF_v = \sqrt{\frac{V_{rms}^2 - V_{dc}^2}{V_{dc}^2}} = \sqrt{\frac{V_{rms}^2}{V_{dc}^2} - 1} = \sqrt{FF^2 - 1} = \sqrt{\frac{1}{\eta_{eff}} - 1}$$

where FF is termed the form factor. RF_v is a measure of the voltage harmonics in the output voltage while if currents are used in the equation, RF_i gives a measure of the current harmonics in the output current. Both FF and RF are applicable to the input and output, and are fully defined in section 14.8.

The general analysis in this chapter is concerned with single and three phase ac supplies mainly feeding inductive dc loads. A load dc back emf is used in modelling the dc machine. Generally, uncontrolled rectifier equations can be derived from the corresponding controlled converter circuit equations by setting the controlled *delay angle* α to zero. Also purely resistive load equations generally can be derived by setting inductance L to zero in the L - R load equations and R - L load equations can be derived from R - L - E equations by setting E , the load back emf, to zero.

14.1 Single-phase full-wave half-controlled converter

14.1.1 Single-phase, full-wave half-controlled circuit with an R-L load

When a converter contains both diodes and thyristors, for example as shown in figure 14.1 parts a to d, the converter is termed half-controlled (or semi-controlled). These four circuits produce identical load and supply waveforms, neglecting any differences in the number and type of semiconductor voltage drops. The power to the load is varied by controlling the angle α , shown in figure 14.1e, at which the bridge thyristors are triggered (after first becoming forward biased). The circuit diodes prevent the load voltage from going negative, extend the conduction period, and reduce the output ac ripple.

The particular application will determine which one of the four circuits should be employed. For example, circuit figure 14.1a contains five devices of which four are thyristors, whereas the other circuits contain fewer devices, of which only two are thyristors. The circuit in figure 14.1b uses the fewest semiconductors, but requires a transformer which introduces extra cost, weight, and size. Also the thyristors experience twice the voltage of the thyristors in the other circuits, $2\sqrt{2} V$ rather than $\sqrt{2} V$. The transformer does provide isolation and voltage matching.

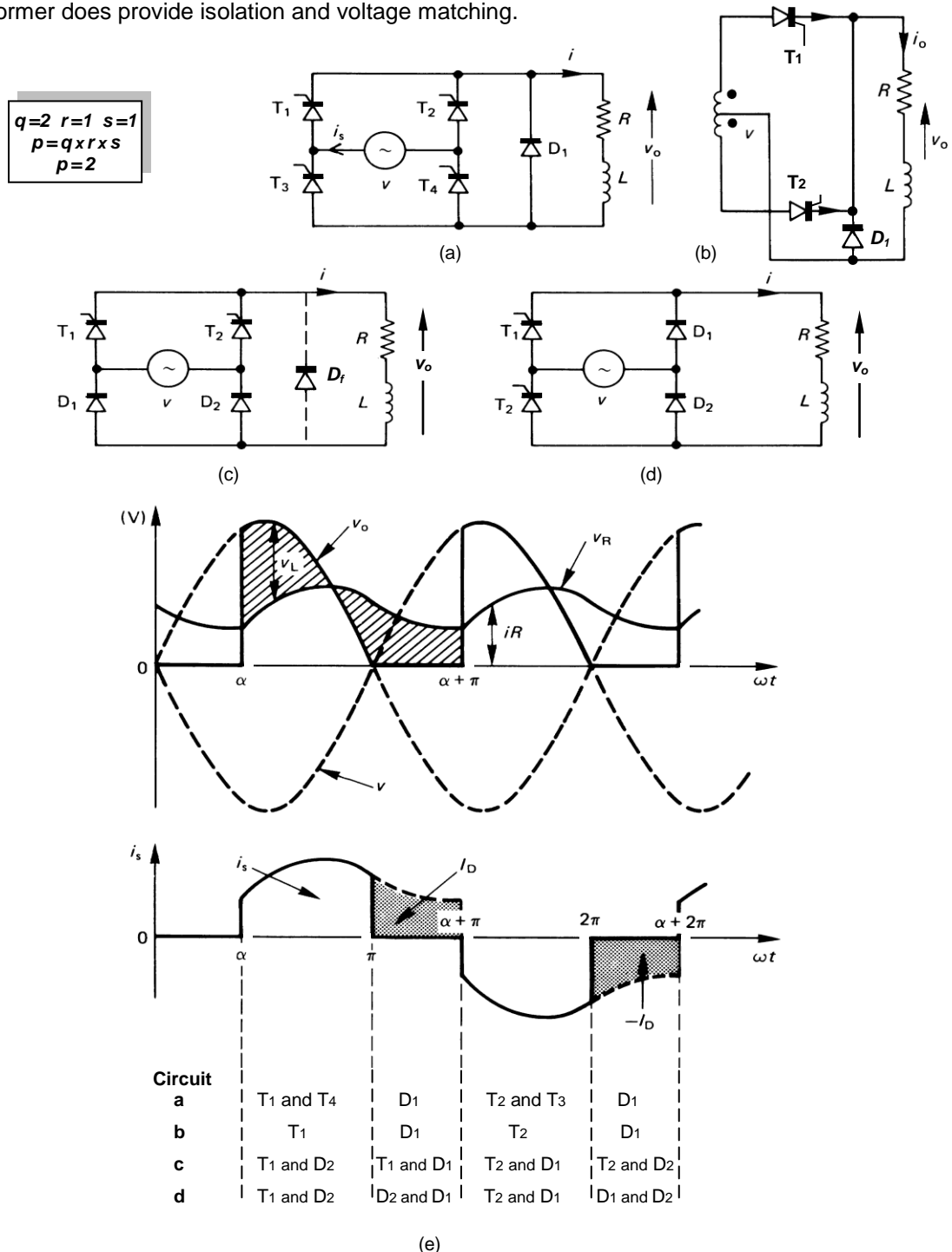

Figure 14.1. Full-wave half-controlled converters with freewheel diodes: (a), (b), (c), and (d) different circuit configurations producing the same output; and (e) circuit voltage and current waveforms and device conduction table.

The thyristor triggering requirements of the circuits in figures 14.1b and c are simple since both thyristors have a common cathode connection. Figure 14.1c may suffer from prolonged shut-down times with highly inductive loads. The diode in the freewheeling path will hold on the freewheeling thyristor, allowing conduction during that thyristors next positive cycle without any gate drive present. The extra diode D_f in figure 14.1c bypasses the bridge thyristors allowing them to drop out of conduction. This is achieved at the expense of an extra device, but the freewheel path conduction losses are decreased since that series circuit now involves only one semiconductor voltage drop. This continued conduction problem does not occur in circuits 14.1a and d since freewheeling does not occur through the circuit thyristors, hence they will drop out of conduction at converter shut-down. The table in figure 14.1e shows which semiconductors are active in each circuit during the various periods of the load cycle.

Circuit waveforms are shown in figure 14.1e. Since the load is a passive L - R circuit, independent of whether the load current is continuous or discontinuous, the mean output voltage and current (neglecting diode voltage drops) are

$$V_o = \bar{I}_o R = \frac{1}{\pi} \int_{\alpha}^{\pi} \sqrt{2} V \sin(\omega t) d\omega t = \frac{\sqrt{2} V}{\pi} (1 + \cos \alpha) \quad (\text{V}) \quad (14.1)$$

$$\bar{I}_o = V_o / R = \frac{\sqrt{2} V}{\pi R} (1 + \cos \alpha) \quad (\text{A})$$

where α is the delay angle from the point at which the associated thyristor first becomes forward-biased and is therefore able to be turned on and conduct current.

The maximum mean output voltage, $\hat{V}_o = 2\sqrt{2}V/\pi$ (also predicted by equation 13.56), occurs at $\alpha = 0$. The normalised mean output voltage V_n is

$$V_n = V_o / \hat{V}_o = 1/2(1 + \cos \alpha) \quad (14.2)$$

The Fourier coefficients of the 2-pulse output voltage are given by equation (14.129). For the single-phase, full-wave, half-controlled case, $p=2$, thus the output voltage harmonics occur at $n=2, 4, 6, \dots$

Equation (14.1) shows that the load voltage is independent of the passive load (because the diodes clamp the load to zero volts thereby preventing the load voltage from going negative), and is a function only of the phase delay angle for a given supply voltage.

The rms value of the load circuit voltage v_o is

$$V_{rms} = \sqrt{\frac{1}{\pi} \int_{\alpha}^{\pi} (\sqrt{2} V \sin \omega t)^2 d\omega t} = V \sqrt{\frac{\pi - \alpha + 1/2 \sin 2\alpha}{\pi}} \quad (\text{V}) \quad (14.3)$$

From the load voltage definitions in section 14.7, the load voltage form factor, FF_v , is

$$FF_v = \frac{V_{rms}}{V_o} = \frac{\sqrt{\pi(\pi - \alpha + 1/2 \sin 2\alpha)}}{\sqrt{2}(1 + \cos \alpha)} \quad (14.4)$$

The ripple voltage is

$$V_{Ri} \triangleq \sqrt{V_{rms}^2 - V_o^2} \quad (14.5)$$

hence the voltage ripple factor RF_v is

$$RF_v \triangleq V_{Ri} / V_o = \sqrt{FF_v^2 - 1} \quad (14.6)$$

The load and supply waveforms and equations, for continuous and discontinuous load current, are the same for all the circuits in figure 14.1. The circuits differ in the device conduction paths as shown in the table in figure 14.1e. After deriving the general load current equations, the current equations applicable to the different circuit devices can be decoded.

14.1.1i - Discontinuous load current, with $\alpha < \pi$ and $\beta - \alpha < \pi$, the load current (and supply current) is based on equation 13.14 namely

$$i(\omega t) = i_s(\omega t) = \sqrt{2} V / Z \left(\sin(\omega t - \phi) - \sin(\alpha - \phi) e^{-\omega t + \alpha / \tan \phi} \right) \quad (\text{A}) \quad (14.7)$$

$$\alpha \leq \omega t \leq \pi$$

where $Z = \sqrt{R^2 + \omega^2 L^2}$ and $\phi = \tan^{-1} \omega L / R$

After $\omega t = \pi$ the load current decreases exponentially to zero through the freewheel diode according to

$$i(\omega t) = i_{Df}(\omega t) = I_{o1\pi} e^{-\omega t / \tan \phi} \quad (\text{A}) \quad 0 \leq \omega t \leq \alpha \quad (14.8)$$

where for $\omega t = \pi$ in equation (14.7)

$$I_{o1\pi} = \sqrt{2} V / Z \sin(\phi - \alpha) (1 - e^{-\pi / \tan \phi})$$

The semiconductor average current ratings can be determined from the average half-cycle freewheeling current, $\bar{I}_{1/2F}$, and the average half-cycle supply current, $\bar{I}_{1/2S}$. For discontinuous load current

$$\bar{I}_{\frac{1}{2}F} = \frac{1}{2} \frac{\sqrt{2} V}{\pi R} \sin \phi \left(\sin \phi - \sin(\alpha - \phi) e^{(\alpha - \pi)/\tan \phi} \right) \quad (14.9)$$

$$\bar{I}_{\frac{1}{2}S} = \frac{1}{2} \bar{I}_o - \bar{I}_{\frac{1}{2}F} = \frac{1}{2} \frac{\sqrt{2} V}{\pi R} \left(\cos^2 \phi + \cos \alpha + \sin \phi \sin(\alpha - \phi) e^{(\alpha - \pi)/\tan \phi} \right) \quad (14.10)$$

14.1.1ii - Continuous load current, with $\alpha < \phi$ and $\beta - \alpha \geq \pi$, the load current is given by equations similar to equations 13.35 and 13.36, specifically

$$i(\omega t) = i_s(\omega t) = \frac{\sqrt{2} V}{Z} \left(\sin(\omega t - \phi) + \frac{\sin \phi e^{-\alpha/\tan \phi} - \sin(\alpha - \phi)}{1 - e^{-\pi/\tan \phi}} e^{-\omega t + \alpha/\tan \phi} \right) \quad (14.11)$$

$\alpha \leq \omega t \leq \pi$ (A)

while the load current when the freewheel diode conducts is

$$i(\omega t) = i_{DF}(\omega t) = I_{01\pi} e^{-\omega t/\tan \phi} \quad (A) \quad (14.12)$$

$0 \leq \omega t \leq \alpha$

where, for $\omega t = \pi$ in equation (14.11)

$$I_{01\pi} = \frac{\sqrt{2} V}{Z} \frac{\sin \phi - \sin(\alpha - \phi) e^{-\pi + \alpha/\tan \phi}}{1 - e^{-\pi/\tan \phi}} \quad (A)$$

The various semiconductor average current ratings can be determined from the average half cycle freewheeling current, $\bar{I}_{\frac{1}{2}F}$, and the average half cycle supply current, $\bar{I}_{\frac{1}{2}S}$. For continuous load current

$$\bar{I}_{\frac{1}{2}F} = \frac{1}{2} \frac{\sqrt{2} V}{\pi R} \sin \phi \frac{\sin \phi - \sin(\alpha - \phi) e^{-\pi + \alpha/\tan \phi}}{1 - e^{-\pi/\tan \phi}} (1 - e^{-\alpha/\tan \phi}) \quad (14.13)$$

$$\begin{aligned} \bar{I}_{\frac{1}{2}S} &= \frac{1}{2} \bar{I}_o - \bar{I}_{\frac{1}{2}F} \\ &= \frac{1}{2} \frac{\sqrt{2} V}{\pi R} \cos \phi \left(\tan \phi \frac{1 - e^{-(\pi + \alpha)/\tan \phi}}{1 - e^{-\pi/\tan \phi}} \left(e^{-\alpha/\tan \phi} \sin \phi - \sin(\alpha - \phi) \right) + \cos \phi + \cos(\alpha - \phi) \right) \end{aligned} \quad (14.14)$$

Table 14.1: Semiconductor average current ratings

Bridge circuit figure 14.1	Number of devices	Average device current	
		Thyristor	Diode
a	4T+1D	1x $\bar{I}_{\frac{1}{2}S}$	2x $\bar{I}_{\frac{1}{2}F}$
b	2T+1D	1x $\bar{I}_{\frac{1}{2}S}$	2x $\bar{I}_{\frac{1}{2}F}$
c	2T+2D	$\frac{1}{2}$ x \bar{I}_o	$\frac{1}{2}$ x \bar{I}_o
d	2T+2D	1x $\bar{I}_{\frac{1}{2}S}$	1x $\bar{I}_{\frac{1}{2}S}$ + 2x $\bar{I}_{\frac{1}{2}F}$

The device conduction table in figure 14.1e can be used to specify average devices currents, for both continuous and discontinuous load current for each of the circuits in figure 14.1, parts a to d.

For a highly inductive load, constant load current, the supply power factor is $pf = \frac{2}{\pi} \sqrt{2} \cos \alpha$.

Critical load inductance

The critical load inductance, to prevent the current falling to zero (becoming discontinuous), is given by

$$\frac{\omega L_{crit}}{R} = \theta - \alpha - \frac{1}{2}\pi + \frac{\alpha + \sin \alpha + \pi \cos \theta}{1 + \cos \alpha} \quad (14.15)$$

for $\alpha \leq \theta$ where

$$\theta = \sin^{-1} \frac{V_o}{\sqrt{2} V} = \sin^{-1} \frac{1 + \cos \alpha}{\pi} \quad (14.16)$$

The minimum current occurs at the angle θ , where the mean output voltage V_o equals the instantaneous load voltage, v_o . When the phase delay angle α is greater than the critical angle θ , $\theta = \alpha$ in equation (14.16) yields (see figure 14.14)

$$\frac{\omega L_{crit}}{R} = -\frac{1}{2}\pi + \frac{\alpha + \sin \alpha + \pi \cos \alpha}{1 + \cos \alpha} \quad (14.17)$$

It is important to note that converter circuits employing diodes cannot be used when inversion is required. Since the converter diodes prevent the output voltage from being negative, (and the current is unidirectional), regeneration from the load into the supply is not achievable.

Figure 14.1a is a fully controlled converter with an $R-L$ load and freewheel diode. In single-phase circuits, this converter essentially behaves as a half-controlled converter.

14.1.2 Single-phase, full-wave, half-controlled circuit with $R-L$ and emf E load

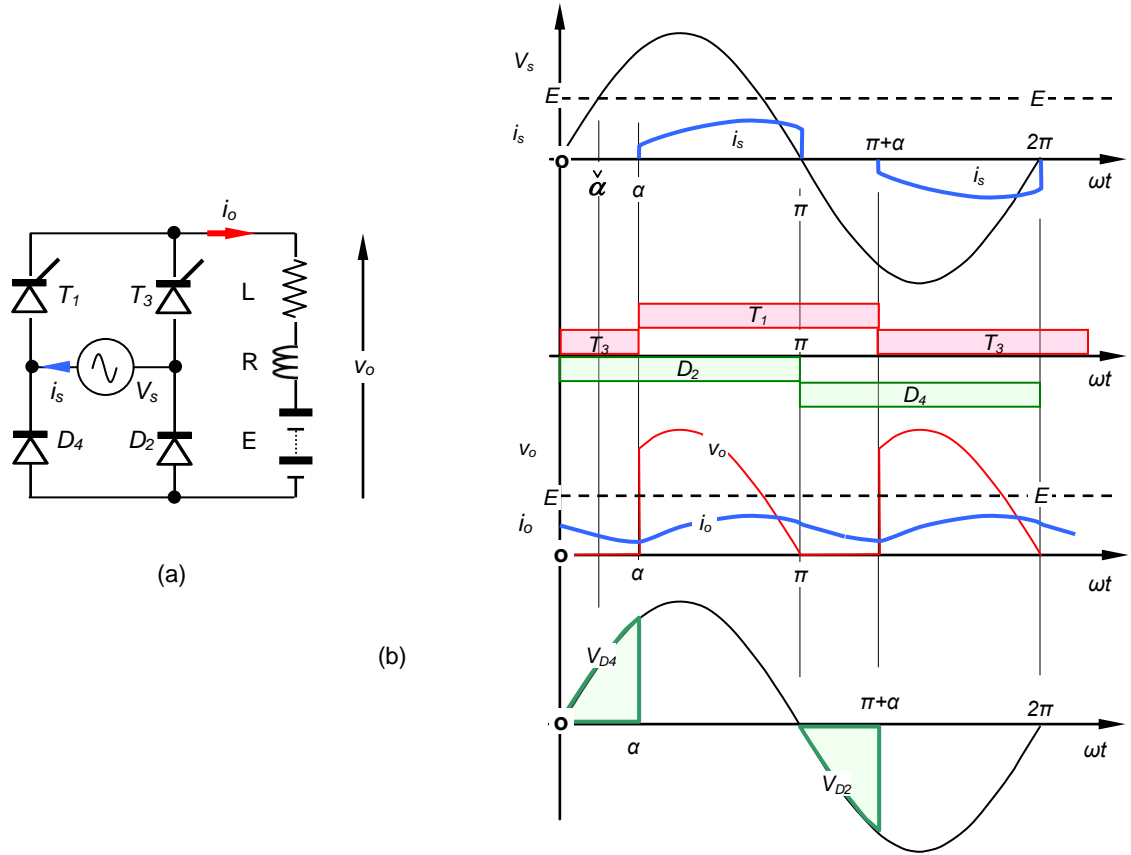

Figure 14.2. Full-wave half-controlled converter with freewheel diodes and back emf: (a) circuit configurations and (b) circuit voltage and current waveforms and device conduction table.

In figure 14.2a, with a load back emf, current begins to flow when the supply instantaneous voltage exceeds the back emf magnitude E , that is when

$$\check{\alpha} = \sin^{-1} \frac{E}{\sqrt{2}V} \tag{14.18}$$

The average load voltage and current are given by

$$V_o = \frac{1}{\pi} \int_{\check{\alpha}}^{\pi} \sqrt{2}V \sin(\omega t) d\omega t = \frac{\sqrt{2}V}{\pi} (1 + \cos \alpha) \tag{V} \tag{14.19}$$

$$\bar{I}_o = \frac{V_o - E}{R} = \frac{\sqrt{2}V}{\pi R} (1 + \cos \alpha - \pi \sin \check{\alpha}) \tag{A}$$

The time domain solution for the load current has two components.

In the period $\alpha \leq \omega t \leq \pi$

When current flows, Kirchhoff's voltage law gives

$$v_o(t) = \sqrt{2}V \sin \omega t = Ri + L \frac{di}{dt} + E \tag{14.20}$$

Assuming **continuous current conduction**, using $R = Z \cos \phi$ and $E = \sqrt{2}V \sin \check{\alpha}$, which yields

$$\begin{aligned} i(\omega t) &= I_1 e^{-\omega t + \alpha / \tan \phi} + \frac{\sqrt{2}V}{Z} \left(\sin(\omega t - \phi) - \frac{E}{\sqrt{2}V} \right) \\ &= I_1 e^{-\omega t + \alpha / \tan \phi} + \frac{\sqrt{2}V}{Z} \left(\sin(\omega t - \phi) - \frac{\sin \check{\alpha}}{\cos \phi} \right) \end{aligned} \tag{14.21}$$

$$\alpha \geq \check{\alpha} \text{ and } i(\omega t = \pi) > 0$$

$$\text{where } Z = \sqrt{R^2 + \omega^2 L^2} \text{ and } \phi = \tan^{-1} \omega L / R$$

In the period $\pi \leq \omega t \leq \pi + \alpha$

$$v_o(t) = 0 = Ri + L \frac{di}{dt} + E \quad (14.22)$$

Solving gives

$$\begin{aligned} i(\omega t) &= I_1 e^{-\omega t + \alpha / \tan \phi} + \frac{\sqrt{2}V}{Z} \left(e^{-\omega t + \pi / \tan \phi} \sin \phi - \frac{E}{\sqrt{2}V} \right) \\ &= I_1 e^{-\omega t + \alpha / \tan \phi} + \frac{\sqrt{2}V}{Z} \left(e^{-\omega t + \pi / \tan \phi} \sin \phi - \frac{\sin \check{\alpha}}{\cos \phi} \right) \end{aligned} \quad (14.23)$$

$$\alpha \geq \check{\alpha} \text{ and } i(\omega t = \pi) > 0$$

For continuous current, satisfying continuous and periodic boundary conditions

$$I_1 = \frac{\sqrt{2}V}{Z} \frac{\left(\sin(\phi - \alpha) - e^{-\alpha / \tan \phi} \sin \phi \right)}{1 - e^{-\pi / \tan \phi}}$$

For $\alpha \leq \omega t \leq \pi$

$$i(\omega t) = \frac{\sqrt{2}V}{Z} \left\{ \frac{e^{-\omega t + \alpha / \tan \phi}}{1 - e^{-\pi / \tan \phi}} \left(\sin(\phi - \alpha) + e^{-\alpha / \tan \phi} \sin \phi \right) + \sin(\omega t - \phi) - \frac{\sin \check{\alpha}}{\cos \phi} \right\} \quad (14.24)$$

For $\pi \leq \omega t \leq \pi + \alpha$

$$i(\omega t) = \frac{\sqrt{2}V}{Z} \left\{ \frac{e^{-\omega t + \alpha / \tan \phi}}{1 - e^{-\pi / \tan \phi}} \left(\sin(\phi - \alpha) + e^{-\alpha / \tan \phi} \sin \phi \right) + e^{-\omega t + \alpha / \tan \phi} \sin \phi - \frac{\sin \check{\alpha}}{\cos \phi} \right\} \quad (14.25)$$

Constant load current

For a highly inductive load the load current can be considered a constant quasi-square wave of amplitude \bar{I}_o , then the rms input supply current

$$I_{i \text{ rms}} = \bar{I}_o \sqrt{1 - \frac{\alpha}{\pi}}$$

The displacement factor = $DF = \cos \frac{1}{2}\alpha$

$$V_i I_{i1} \cos \frac{1}{2}\alpha = V_o \bar{I}_o = \frac{\sqrt{2}V}{\pi} (1 + \cos \alpha) \bar{I}_o$$

$$\text{that is } I_{i1} = \frac{2\sqrt{2}}{\pi} \bar{I}_o \cos \frac{1}{2}\alpha$$

$$\therefore \text{ distortion factor} = \frac{I_{i1}}{I_{i \text{ rms}}} = 2 \sqrt{\frac{2}{\pi(\pi - \alpha)}} \cos \frac{1}{2}\alpha$$

\therefore Power factor = displacement factor \times distortion factor

$$pf = \sqrt{\frac{2}{\pi(\pi - \alpha)}} (1 + \cos \alpha)$$

The input current total harmonic distortion is

$$THD = \frac{\sqrt{I_i^2 - I_{i1}^2}}{I_{i1}} = \sqrt{\frac{I_i^2}{I_{i1}^2} - 1} = \sqrt{\frac{\pi(\pi - \alpha)}{4(1 + \cos \alpha)} - 1}$$

Discontinuous conduction

At $\omega t \leq \alpha$ equation (14.24) must be greater than zero for continuous conduction, that is

$$\frac{\sin(\phi - \alpha) + e^{-\alpha / \tan \phi} \sin \phi}{1 - e^{-\pi / \tan \phi}} + \sin(\alpha - \phi) - \frac{\sin \check{\alpha}}{\cos \phi} \geq 0$$

That is

$$\frac{e^{-\pi / \tan \phi} \sin(\phi - \alpha) + e^{-\alpha / \tan \phi} \sin \phi}{1 - e^{-\pi / \tan \phi}} - \frac{\sin \check{\alpha}}{\cos \phi} \geq 0 \quad (14.26)$$

Two discontinuous conduction conditions exist:

- i. The current is forced to zero before load freewheeling, when E exceeds the instantaneous source voltage, that is $\pi - \check{\alpha} < \beta \leq \pi$
- ii. The current is forced to zero during load freewheeling, that is $\pi < \beta \leq \pi + \alpha$

In both cases average output current is

$$\bar{I}_o = \frac{V_o - E}{R}$$

i. In the first case

The average output voltage is

$$V_o = \frac{1}{\pi} \left[\int_{\check{\alpha}}^{\beta} \sqrt{2}V \sin \omega t d\omega t + \int_{\pi}^{\pi+\alpha} \sqrt{2}V \sin \check{\alpha} d\omega t \right] \quad \beta \leq \pi$$

$$V_o = \frac{\sqrt{2}V}{\pi} \left[-\cos \beta + \cos \alpha + \alpha \sin \check{\alpha} \right] \tag{14.27}$$

Hence

$$\bar{I}_o = \frac{V_o - E}{R} = \frac{\sqrt{2}V}{\pi R} \left[-\cos \beta + \cos \alpha + (\alpha - \pi) \sin \check{\alpha} \right] \tag{14.28}$$

The rms output voltage is

$$V_{o\,rms} = \frac{1}{\pi} \left[\int_{\check{\alpha}}^{\beta} (\sqrt{2}V \sin \omega t)^2 d\omega t + \int_{\pi}^{\pi+\alpha} (\sqrt{2}V \sin \check{\alpha})^2 d\omega t \right]$$

$$= \frac{\sqrt{2}V}{\pi} \left[\frac{1}{2}(\beta - \alpha) + \frac{1}{4} \sin 2\alpha - \frac{1}{4} \sin 2\beta + \alpha \right]^{1/2} \tag{14.29}$$

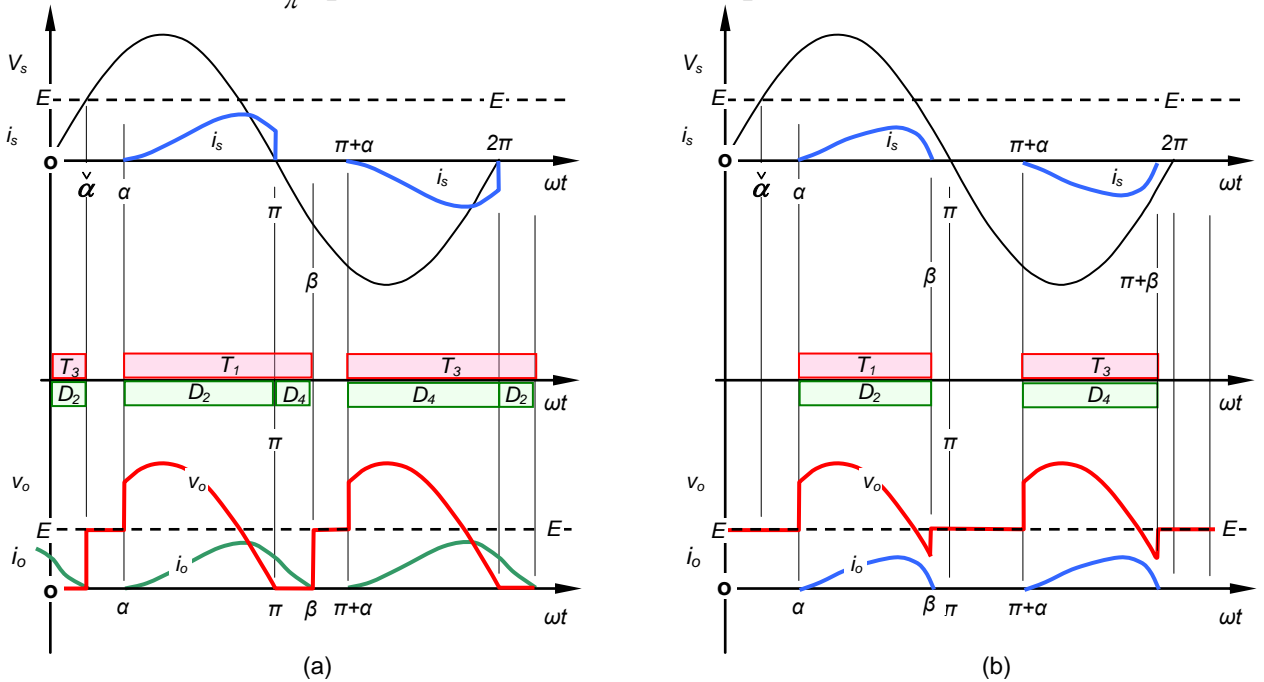

Figure 14.3. Full-wave half-controlled converter with freewheel diodes and back emf during discontinuous conduction: (a) $\pi - \check{\alpha} < \beta \leq \pi$ and (b) $\pi < \beta \leq \pi + \alpha$.

In each case the rms output current can be derived from the time-current equations, which are used to find the current extinction angle β .

For $\alpha \leq \omega t \leq \beta \leq \pi$

$$v_o(t) = \sqrt{2}V \sin \omega t = Ri + L \frac{di}{dt} + E \tag{14.30}$$

which has the general solution

$$i(\omega t) = I_o e^{-\omega t + \alpha / \tan \phi} + \frac{\sqrt{2}V}{Z} \left(\sin(\omega t - \phi) - \frac{\sin \check{\alpha}}{\cos \phi} \right)$$

where a zero initial current boundary condition gives

$$I_o = \frac{\sqrt{2}V}{Z} \left(\sin(\phi - \alpha) + \frac{\sin \check{\alpha}}{\cos \phi} \right)$$

That is

$$i(\omega t) = \frac{\sqrt{2}V}{Z} \left[\left(\sin(\phi - \alpha) + \frac{\sin \check{\alpha}}{\cos \phi} \right) e^{-\omega t + \alpha / \tan \phi} + \sin(\omega t - \phi) - \frac{\sin \check{\alpha}}{\cos \phi} \right] \quad (14.31)$$

At $\omega t = \beta \leq \pi$, $i(\beta) = 0$, that is β is found iteratively from

$$\left(\sin(\phi - \alpha) + \frac{\sin \check{\alpha}}{\cos \phi} \right) e^{-\beta + \alpha / \tan \phi} + \sin(\beta - \phi) = \frac{\sin \check{\alpha}}{\cos \phi} \quad (14.32)$$

ii. In the second case:

The average output voltage is

$$V_o = \frac{1}{\pi} \left[\int_{\alpha}^{\pi} \sqrt{2}V \sin \omega t \, d\omega t + \int_{\beta}^{\pi + \alpha} \sqrt{2}V \sin \check{\alpha} \, d\omega t \right] \quad \beta \geq \pi$$

$$V_o = \frac{\sqrt{2}V}{\pi} \left[1 + \cos \alpha + (\pi + \alpha - \beta) \sin \check{\alpha} \right] \quad (14.33)$$

hence

$$\bar{I}_o = \frac{V_o - E}{R} = \frac{\sqrt{2}V}{\pi R} \left[1 + \cos \alpha + (\alpha - \beta) \sin \check{\alpha} \right] \quad (14.34)$$

The rms output voltage is

$$V_{o\,rms} = \frac{1}{\pi} \left[\int_{\alpha}^{\pi} (\sqrt{2}V \sin \omega t)^2 \, d\omega t + \int_{\beta}^{\pi + \alpha} (\sqrt{2}V \sin \check{\alpha})^2 \, d\omega t \right] \quad (14.35)$$

$$= \frac{\sqrt{2}V}{\pi} \left[\frac{1}{2}(\pi - \alpha) + \frac{1}{4} \sin 2\alpha + (\pi + \alpha - \beta) \sin^2 \check{\alpha} \right]^{1/2}$$

For $\alpha \leq \omega t \leq \pi$

$$v_o(t) = \sqrt{2}V \sin \omega t = Ri + L \frac{di}{dt} + E \quad (14.36)$$

yielding

$$i(\omega t) = I_o e^{-\omega t + \alpha / \tan \phi} + \frac{\sqrt{2}V}{Z} \left(\sin(\omega t - \phi) - \frac{\sin \check{\alpha}}{\cos \phi} \right)$$

where a zero initial current boundary condition gives

$$I_o = \frac{\sqrt{2}V}{Z} \left(\sin(\phi - \alpha) + \frac{\sin \check{\alpha}}{\cos \phi} \right)$$

That is

$$i(\omega t) = \frac{\sqrt{2}V}{Z} \left[\left(\sin(\phi - \alpha) + \frac{\sin \check{\alpha}}{\cos \phi} \right) e^{-\omega t + \alpha / \tan \phi} + \sin(\omega t - \phi) - \frac{\sin \check{\alpha}}{\cos \phi} \right] \quad (14.37)$$

For $\pi \leq \omega t \leq \beta$

$$v_o(t) = 0 = Ri + L \frac{di}{dt} + E \quad (14.38)$$

which yields

$$i(\omega t) = I_1 e^{-\omega t + \pi / \tan \phi} - \frac{\sqrt{2}V}{Z} \frac{\sin \check{\alpha}}{\cos \phi}$$

where for continuous current at the boundary

$$I_1 = \frac{\sqrt{2}V}{Z} \left(\sin \phi + e^{\alpha - \pi / \tan \phi} \left(\sin(\phi - \alpha) + \frac{\sin \check{\alpha}}{\cos \phi} \right) \right) \quad (14.39)$$

That is

$$i(\omega t) = \frac{\sqrt{2}V}{Z} \left[\left(\sin(\phi - \alpha) + \frac{\sin \alpha}{\cos \phi} \right) e^{-\omega t + \alpha / \tan \phi} + e^{-\omega t + \pi / \tan \phi} \sin \phi - \frac{\sin \alpha}{\cos \phi} \right] \quad (14.40)$$

Equating to zero at the conduction extinction angle β gives

$$\left(\sin(\phi - \alpha) + \frac{\sin \alpha}{\cos \phi} \right) e^{-\beta + \alpha / \tan \phi} + e^{-\beta + \pi / \tan \phi} \sin \phi - \frac{\sin \alpha}{\cos \phi} = 0$$

$$\beta = \tan \phi \times \ln \left\{ \frac{\left(\sin(\phi - \alpha) + \frac{\sin \alpha}{\cos \phi} \right) e^{\alpha / \tan \phi} + e^{\pi / \tan \phi} \sin \phi}{\frac{\sin \alpha}{\cos \phi}} \right\} \quad (14.41)$$

Example 14.1: Single-phase, full-wave half-controlled rectifier

A 120V ac single-phase, full-wave half-controlled rectifier supports a 100A constant load current at a delay trigger angle of 90° . Specify and characterise the input and output waveforms.

Solution

The output voltage waveform is defined by average and rms voltages of

$$\bar{V}_o = \frac{\sqrt{2}V_s}{\pi} (1 + \cos \alpha) = \frac{\sqrt{2} \times 120V}{\pi} (1 + \cos 1/2\pi) = 54.0V$$

and

$$V_{o,rms} = V_s \sqrt{\frac{\pi - \alpha + 1/2 \sin 2\alpha}{\pi}} = 120V \sqrt{\frac{\pi - 1/2\pi + 1/2 \sin \pi}{\pi}} = 84.85V$$

The input fundamental and rms currents are

$$I_{s1} = \frac{2\sqrt{2}}{\pi} I_o \cos 1/2\alpha = \frac{2\sqrt{2}}{\pi} 100A \times \cos 1/4\pi = 63.3A$$

and

$$I_s = I_o \sqrt{1 - \alpha / \pi} = 100A \sqrt{1 - 1/2\pi / \pi} = 70.7A$$

The various input factors are

$$DPF = \cos 1/2\alpha = \cos 1/4\pi = 0.707$$

$$DF = \sqrt{\frac{4(1 + \cos \alpha)}{\pi(\pi - \alpha)}} = \sqrt{\frac{4(1 + \cos 1/2\pi)}{\pi(\pi - 1/2\pi)}} = 0.90$$

$$pf = DF \times DPF = 0.90 \times 0.707 = 0.636$$

$$THD = \sqrt{\frac{I_{s1}^2}{I_s^2} - 1} = \sqrt{\frac{1}{DF^2} - 1} = \sqrt{\frac{1}{0.90^2} - 1} = 0.484$$

♣

14.2 Single-phase controlled thyristor converter circuits

14.2.1 Single-phase, half-wave controlled circuit with an R-L load

The rectifying diode in the circuit of figure 13.1 can be replaced by a thyristor as shown in figure 14.4a to form a half-wave controlled rectifier circuit with an R-L load. The output voltage is now controlled by the thyristor trigger angle, α . The output voltage ripple is at the supply frequency. Circuit waveforms are shown in figure 14.4b, where the load inductor voltage equal areas are shaded.

The output current, hence output voltage, for the series circuit are given by

$$v_o(t) = L \frac{di}{dt} + Ri = \sqrt{2}V \sin \omega t \quad (V) \quad (14.42)$$

$$\alpha \leq \omega t \leq \beta \quad (\text{rad})$$

where phase delay angle α and current extinction angle β are shown in the waveform in figure 14.4b and are the zero load (and supply) current points.

Solving equation (14.42) yields the load and supply current

$$i(\omega t) = \frac{\sqrt{2} V}{Z} \{ \sin(\omega t - \phi) - \sin(\alpha - \phi) e^{(\alpha - \omega t)/\tan \phi} \} \quad (A)$$

$$\text{where } Z = \sqrt{R^2 + (\omega L)^2} \quad (\text{ohms}) \quad \alpha \leq \omega t \leq \beta \quad (14.43)$$

$$\tan \phi = \omega L / R$$

and i is zero elsewhere.

The current extinction angle β is dependent on the load impedance and thyristor trigger angle α , and can be determined by solving equation (14.43) with $\omega t = \beta$ when $i(\beta) = 0$, that is

$$\sin(\beta - \phi) = \sin(\alpha - \phi) e^{(\alpha - \beta)/\tan \phi} \quad (14.44)$$

This is a transcendental equation. A family of curves of current conduction angle versus delay angle, that is $\beta - \alpha$ versus α , is shown in figure 14.5a. The straight line plot for $\phi = 1/2\pi$ is for a purely inductive load, whereas $\phi = 0$ is a straight line for a purely resistive load.

The mean load voltage, whence the mean load current, is given by

$$V_o = \frac{1}{2\pi} \int_{\alpha}^{\beta} \sqrt{2} V \sin \omega t \, d\omega t \quad (14.45)$$

$$V_o = \bar{I}_o R = \frac{\sqrt{2} V}{2\pi} (\cos \alpha - \cos \beta) \quad (V)$$

where the angle β can be extracted from figure 14.5a.

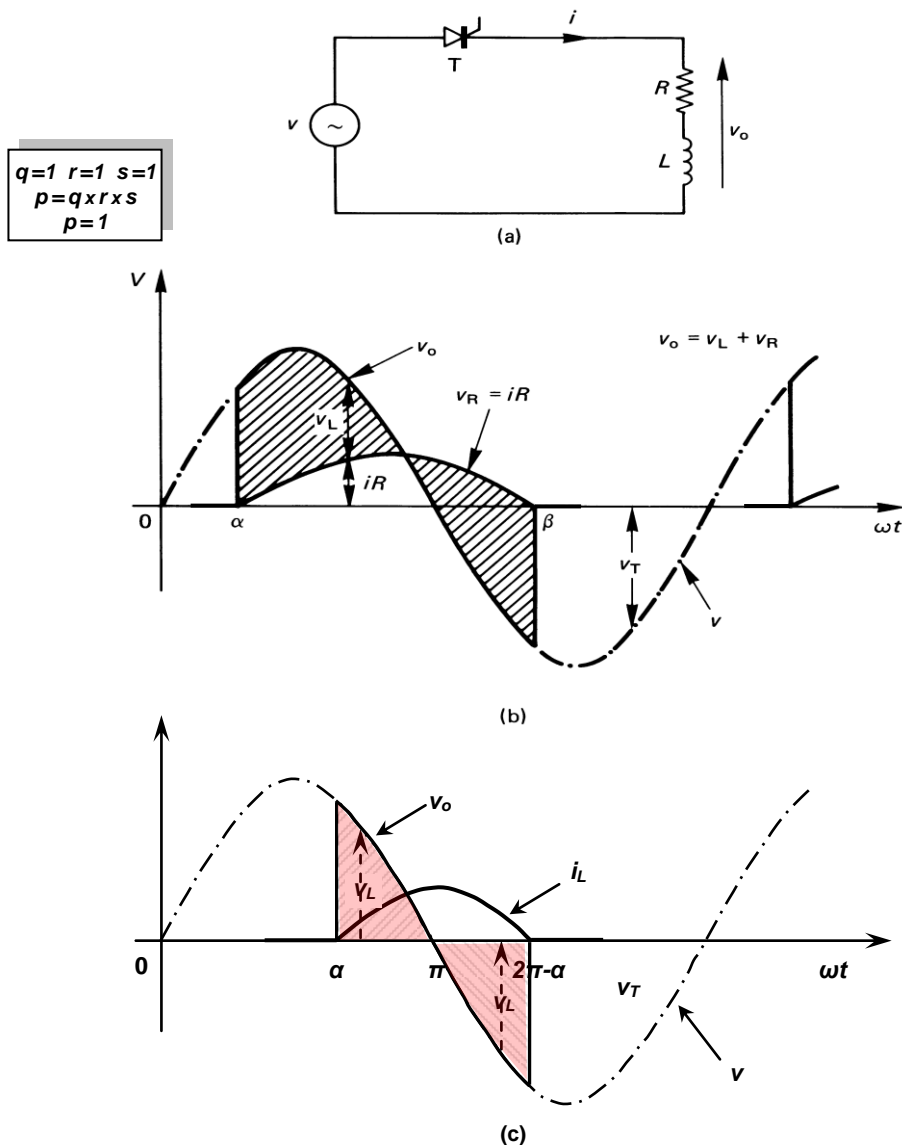

Figure 14.4. Single-phase half-wave controlled converter: (a) circuit diagram; (b) circuit waveforms for an R-L load; and (c) purely inductive load.

The rms load voltage is

$$V_{rms} = \left[\frac{1}{2\pi} \int_{\alpha}^{\beta} (\sqrt{2}V)^2 \sin^2 \omega t \, d\omega t \right]^{1/2} \tag{14.46}$$

$$= V \left[\frac{1}{2\pi} \{ (\beta - \alpha) - \frac{1}{2}(\sin 2\beta - \sin 2\alpha) \} \right]^{1/2}$$

The rms current involves integration of equation (14.43), squared, giving

$$I_{rms} = \frac{V}{Z} \left[\frac{1}{2\pi} \left((\beta - \alpha) - \frac{\sin(\beta - \alpha) \cos(\alpha + \phi + \beta)}{\cos \phi} \right) \right]^{1/2} \tag{14.47}$$

Iterative solutions to equation (14.44) are shown in figure 14.5a, where it is seen that two straight-line relationships exist that relate α and $\beta - \alpha$. Exact solutions to equation (14.44) exist for these two cases. That is, exact tractable solutions exist for the purely resistive load, $\phi = 0$, and the purely inductive load, $\phi = \frac{1}{2}\pi$.

14.2.1i - Case 1: Purely resistive load. From equation (14.43), $Z = R$, $\phi = 0$, and the current is given by

$$i(\omega t) = \frac{\sqrt{2} V}{R} \sin \omega t \tag{A} \tag{14.48}$$

$\alpha \leq \omega t \leq \pi$ and $\beta = \pi \forall \alpha$

The average load voltage, hence average load current, are

$$V_o = \frac{1}{2\pi} \int_{\alpha}^{\pi} \sqrt{2}V \sin \omega t \, d\omega t \tag{14.49}$$

$$V_o = \bar{I}_o R = \frac{\sqrt{2}V}{2\pi} (1 + \cos \alpha) \tag{V}$$

where the maximum output voltage is 0.45V for zero delay angle.

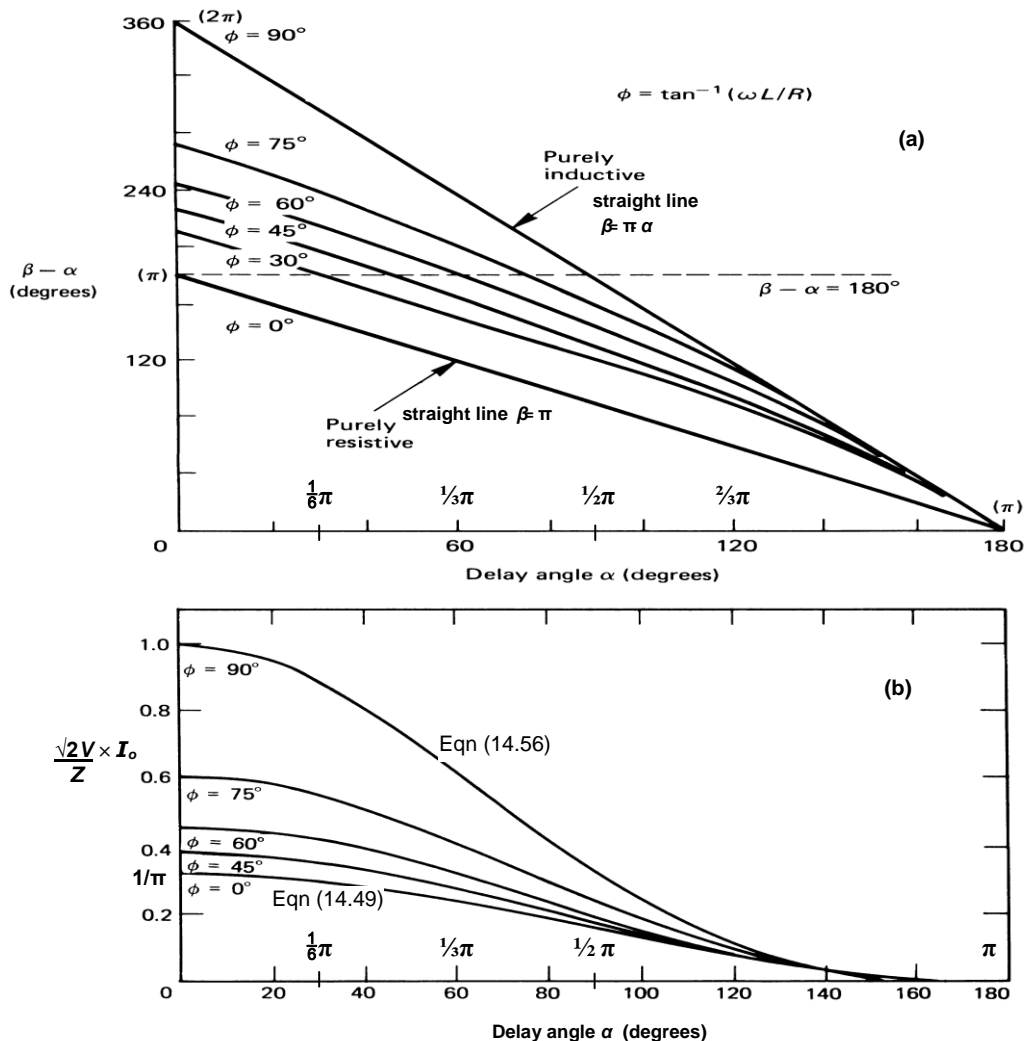

Figure 14.5. Half-wave, controlled converter thyristor trigger delay angle α versus: (a) thyristor conduction angle, $\beta - \alpha$, and (b) normalised mean load current.

The rms output voltage is

$$\begin{aligned} V_{rms} &= \left[\frac{1}{2\pi} \int_{\alpha}^{\pi} (\sqrt{2}V)^2 \sin^2 \omega t \, d\omega t \right]^{1/2} \\ &= V \left[\frac{1}{2\pi} \{(\pi - \alpha) + \frac{1}{2} \sin 2\alpha\} \right]^{1/2} \end{aligned} \quad (14.50)$$

Since the load is purely resistive, $I_{rms} = V_{rms} / R$ and the voltage and current factors (form and ripple) are equal. The power delivered to the load is $P_o = I_{rms}^2 R$.

The output voltage form factor (and output current form factor for a purely resistive load) is

$$FF_{vo} = \frac{V_{rms}}{V_o} = \frac{\sqrt{(\pi - \alpha) + \frac{1}{2} \sin 2\alpha}}{1 + \cos \alpha} \quad (14.51)$$

The supply power factor, for a resistive load, is $P_{out} / V_{rms} I_{rms}$, that is

$$pf = \sqrt{\frac{1}{2} - \frac{\alpha}{2\pi} + \frac{\sin 2\alpha}{4\pi}} \quad (14.52)$$

14.2.1ii - Case 2: Purely inductive load. Circuit waveforms showing equal inductor voltage areas are shown in figure 14.4c. From equation (14.43), $Z = \omega L$, $\phi = \frac{1}{2}\pi$, and the output voltage and current are given by

$$v_o(\omega t) = \begin{cases} \sqrt{2}V \sin \omega t & \alpha \leq \omega t \leq 2\pi - \alpha \\ 0 & \text{elsewhere} \end{cases} \quad (14.53)$$

$$\begin{aligned} i(\omega t) &= \frac{\sqrt{2} V}{\omega L} (\sin(\omega t - \frac{1}{2}\pi) - \sin(\alpha - \frac{1}{2}\pi)) \quad (A) \\ &= \frac{\sqrt{2} V}{\omega L} (\cos \alpha - \cos \omega t) \quad \alpha \leq \omega t \leq \beta \text{ and } \beta = 2\pi - \alpha \end{aligned} \quad (14.54)$$

The average load voltage, based on the equal area criterion, is zero

$$V_o = \frac{1}{2\pi} \int_{\alpha}^{2\pi-\alpha} \sqrt{2}V \sin \omega t \, d\omega t = 0 \quad (14.55)$$

The average output current is

$$\begin{aligned} \bar{I}_o &= \frac{1}{2\pi} \int_{\alpha}^{2\pi-\alpha} \frac{\sqrt{2} V}{\omega L} \{\cos \alpha - \cos \omega t\} \, d\omega t \\ &= \frac{\sqrt{2} V}{\pi \omega L} [(\pi - \alpha) \cos \alpha + \sin \alpha] \end{aligned} \quad (14.56)$$

The rms output current is derived from

$$\begin{aligned} I_{rms} &= \frac{\sqrt{2} V}{\omega L} \left[\frac{1}{2\pi} \int_{\alpha}^{2\pi-\alpha} (\cos \alpha - \cos \omega t)^2 \, d\omega t \right]^{1/2} \\ &= \frac{V}{X} \left[\frac{1}{\pi} \left\{ (\pi - \alpha)(2 + \cos 2\alpha) + \frac{3}{2} \sin 2\alpha \right\} \right]^{1/2} \end{aligned} \quad (14.57)$$

The rms output voltage is

$$\begin{aligned} V_{rms} &= \left[\frac{1}{2\pi} \int_{\alpha}^{2\pi-\alpha} (\sqrt{2}V)^2 \sin^2 \omega t \, d\omega t \right]^{1/2} \\ &= V \left[\frac{1}{\pi} \{(\pi - \alpha) + \frac{1}{2} \sin 2\alpha\} \right]^{1/2} \end{aligned} \quad (14.58)$$

Since the load is purely inductive, $P_o = 0$ and the load voltage ripple factor is undefined since $V_o = 0$. By setting $\alpha = 0$, the equations (14.48) to (14.58) are valid for the uncontrolled rectifier considered in section 13.1.3, for a purely resistive and purely inductive load, respectively.

14.2.1iii - Case 3: Back emf E and R-L load. With a load back emf, current begins to flow when the supply instantaneous voltage exceeds the back emf magnitude E , that is when

$$\alpha = \sin^{-1} \frac{E}{\sqrt{2}V} \quad (14.59)$$

When current flows, Kirchhoff's voltage law gives

$$v_o(t) = \sqrt{2}V \sin \omega t = Ri + L \frac{di}{dt} + E \quad (14.60)$$

Assuming **continuous current conduction**, using $R=Z\cos\phi$ and $E=\sqrt{2}V_s\sin\check{\alpha}$, which yields

$$i(\omega t) = \frac{\sqrt{2}V}{Z} \sin(\omega t - \phi) - \frac{E}{R} - \left(\frac{\sqrt{2}V}{Z} \sin(\alpha - \phi) - \frac{E}{R} \right) e^{-\omega t + \alpha / \tan \phi}$$

$$= \frac{\sqrt{2}V}{Z} \left[\sin(\omega t - \phi) - \frac{\sin\check{\alpha}}{\cos\phi} - \left(\sin(\alpha - \phi) - \frac{\sin\check{\alpha}}{\cos\phi} \right) e^{-\omega t + \alpha / \tan \phi} \right] \quad (14.61)$$

$$\alpha \geq \check{\alpha} \text{ and } i(\omega t = 2\pi + \alpha) > 0$$

The load power is given by

$$P_L = I_{rms}^2 R + \bar{I}_o R \quad (14.62)$$

while the supply power factor is given by

$$pf = \frac{P_L}{V I_{rms}} = \frac{I_{rms}^2 R + \bar{I}_o R}{V I_{rms}} \quad (14.63)$$

The solution for the uncontrolled converter (a half-wave rectifier) is found by setting $\alpha = \check{\alpha}$, eqn (14.59).

The boundary for continuous current conduction is when $i > 0$ at the end of the conduction period when $\omega t = 2\pi + \alpha$, that is

$$\sin(\alpha - \phi) - \frac{\sin\check{\alpha}}{\cos\phi} - \left(\sin(\alpha - \phi) - \frac{\sin\check{\alpha}}{\cos\phi} \right) e^{-2\pi / \tan \phi} \geq 0$$

That is, continuous conduction occurs when

$$\sin(\alpha - \phi) \geq \frac{\sin\check{\alpha}}{\cos\phi} \quad (14.64)$$

With **discontinuous conduction**, the output current is still given by equation (14.61), until the current falls to zero at the extinction angle β . The extinction angle β is found from the boundary condition $i(\omega t) = i(\beta) = 0$, for $2\pi + \alpha > \beta > \frac{1}{2}\pi$, in equation (14.61). That is, β is found iteratively from:

$$\sin(\beta - \phi) - \frac{\sin\check{\alpha}}{\cos\phi} \left(1 - e^{-\alpha - \beta / \tan \phi} \right) - e^{-\alpha - \beta / \tan \phi} \sin(\alpha - \phi) = 0 \quad (14.65)$$

In the interval between $\beta \leq \omega t \leq 2\pi + \alpha$ no current flows and the output voltage is the load back emf, $E = \sqrt{2}V_s\sin\check{\alpha}$. The average output voltage, hence current are given by

$$V_o = \int_{\alpha}^{\beta} \sqrt{2}V \sin \omega t \, d\omega t + \int_{\beta}^{2\pi + \alpha} E \, d\omega t$$

$$= \int_{\alpha}^{\beta} \sqrt{2}V \sin \omega t \, d\omega t + \int_{\beta}^{2\pi + \alpha} \sqrt{2}V \sin\check{\alpha} \, d\omega t$$

$$V_o = \frac{\sqrt{2}V}{2\pi} \left[\cos\alpha - \cos\beta + (2\pi + \alpha - \beta) \times \sin\check{\alpha} \right] \quad (14.66)$$

Therefore

$$\bar{I}_o = \frac{V_o - E}{R} = \frac{V_o - \sqrt{2}V \sin\check{\alpha}}{R}$$

$$\bar{I}_o = \frac{\sqrt{2}V}{R} \frac{1}{2\pi} \left[\cos\alpha - \cos\beta + (\pi + \alpha - \beta) \times \sin\check{\alpha} \right] \quad (14.67)$$

Example 14.2: Single-phase, half-wave controlled rectifier

The ac supply of the half-wave controlled single-phase converter in figure 14.4a is $v = \sqrt{2} 240 \sin\omega t$. For the following loads

Load #1: $R = 10\Omega$, $\omega L = 0\Omega$

Load #2: $R = 0\Omega$, $\omega L = 10\Omega$

Load #3: $R = 7.1\Omega$, $\omega L = 7.1\Omega$

Determine in each load case, for a firing delay angle $\alpha = \pi/6$

- the conduction angle $\gamma = \beta - \alpha$, hence the current extinction angle β
- the dc output voltage and the average output current
- the rms load current and voltage, load current and voltage ripple factor, and power dissipated in the load
- the supply power factor

Solution

Load #1: $Z = R = 10\Omega$, $\omega L = 0\Omega$

From equation (14.43), $Z = 10\Omega$ and $\phi = 0^\circ$.

From equation (14.48), $\beta = \pi$ for all α , thus for $\alpha = \pi/6$, $\gamma = \beta - \alpha = 5\pi/6$.

From equation (14.49)

$$\begin{aligned} V_o &= \bar{I}_o R = \frac{\sqrt{2}V}{2\pi} (1 + \cos \alpha) \\ &= \frac{\sqrt{2}V}{2\pi} (1 + \cos \pi/6) = 100.9V \end{aligned}$$

The average load current is

$$\bar{I}_o = V_o / R = \frac{\sqrt{2}V}{2\pi R} (1 + \cos \alpha) = 100.9V/10\Omega = 10.1A.$$

The rms load voltage is given by equation (14.50), that is

$$\begin{aligned} V_{rms} &= V \left[\frac{1}{2\pi} \left\{ (\pi - \alpha) + \frac{1}{2} \sin 2\alpha \right\} \right]^{1/2} \\ &= 240V \times \left[\frac{1}{2\pi} \left\{ (\pi - \pi/6) + \frac{1}{2} \sin \pi/3 \right\} \right]^{1/2} = 167.2V \end{aligned}$$

Since the load is purely resistive, the power delivered to the load is

$$P_o = I_{rms}^2 R = V_{rms}^2 / R = 167.2V^2 / 10\Omega = 2797.0W$$

$$I_{rms} = V_{rms} / R = 167.2V / 10\Omega = 16.8A$$

For a purely resistive load, the voltage and current factors are equal:

$$FF_i = FF_v = \frac{167.2V}{100.9V} = \frac{16.8A}{10.1A} = 1.68$$

$$RF_i = RF_v = \sqrt{FF^2 - 1} = 1.32$$

The power factor is

$$pf = \frac{2797W}{240V \times 16.8A} = 0.70$$

Alternatively, use of equation (14.52) gives

$$pf = \sqrt{\frac{1}{2} - \frac{\pi/6}{2\pi} + \frac{\sin \pi/6}{4\pi}} = 0.70$$

Load #2: $R = 0\Omega$, $Z = X = \omega L = 10\Omega$

From equation (14.43), $Z = X = 10\Omega$ and $\phi = 1/2\pi$. From equation (14.54), which is based on the equal area criterion, $\beta = 2\pi - \alpha$, thus for $\alpha = \pi/6$, $\beta = 11\pi/6$ whence the conduction period is $\gamma = \beta - \alpha = 5\pi/3$. From equation (14.55) the average output voltage is

$$V_o = 0V$$

The average load current is

$$\begin{aligned} \bar{I}_o &= \frac{\sqrt{2}V}{\pi \omega L} \left[(\pi - \alpha) \cos \alpha + \sin \alpha \right] \\ &= \frac{\sqrt{2} \cdot 240}{\pi \times 10} \times \left[(5\pi/6) \cos \pi/6 + \sin \pi/6 \right] = 14.9A \end{aligned}$$

Using equations (14.57) and (14.58), the load rms voltage and current are

$$V_{rms} = 240V \left[\frac{1}{\pi} \left\{ \pi - \frac{\pi}{6} + \frac{1}{2} \sin \frac{\pi}{3} \right\} \right]^{1/2} = 236.5V$$

$$I_{rms} = \frac{240V}{10\Omega} \left[\frac{1}{\pi} \left\{ (\pi - \pi/6) (2 + \cos 2\alpha) + \frac{3}{2} \sin \frac{\pi}{3} \right\} \right]^{1/2} = 37.9A$$

Since the load is purely inductive, the power delivered to the load is zero, as is the power factor, and the output voltage ripple factor is undefined. The output current ripple factor is

$$FF_i = \frac{I_{rms}}{\bar{I}_o} = \frac{37.9A}{14.9A} = 2.54 \quad \text{whence} \quad RF_i = \sqrt{2.54^2 - 1} = 2.34$$

Load #3: $R = 7.1\Omega$, $\omega L = 7.1\Omega$

From equation (14.43), $Z = 10\Omega$ and $\phi = 1/4\pi$.

From figure 14.5a, for $\phi = 1/4\pi$ and $\alpha = \pi/6$, $\gamma = \beta - \alpha = 195^\circ$ whence $\beta = 225^\circ$.

Iteration of equation (14.44) gives $\beta = 225.5^\circ = 3.936$ rad. From equation (14.45)

$$\begin{aligned} V_o &= \bar{I}_o R = \frac{\sqrt{2}V}{2\pi} (\cos \alpha - \cos \beta) \\ &= \frac{\sqrt{2} \times 240}{2\pi} (\cos 30^\circ - \cos 225^\circ) = 85.0V \end{aligned}$$

The average load current is

$$\begin{aligned} \bar{I}_o &= V_o / R \\ &= 85.0V / 7.1\Omega = 12.0A \end{aligned}$$

Alternatively, the average current can be extracted from figure 14.5b, which for $\phi = 1/4\pi$ and $\alpha = \pi/6$ gives the normalised current as 0.35, thus

$$\begin{aligned} \bar{I}_o &= \sqrt{2}V/Z \times 0.35 \\ &= \sqrt{2} \times 240V / 10\Omega \times 0.35 = 11.9A \end{aligned}$$

From equation (14.47), the rms current is

$$\begin{aligned} I_{rms} &= \frac{V}{Z} \left[\frac{1}{2\pi} \left((\beta - \alpha) - \frac{\sin(\beta - \alpha) \cos(\alpha + \phi + \beta)}{\cos \phi} \right) \right]^{1/2} \\ &= \frac{240V}{10\Omega} \times \left[\frac{1}{2\pi} \left((3.93 - \pi/6) - \frac{\sin(3.93 - \pi/6) \cos(\pi/6 + 1/4\pi + 3.93)}{\cos 1/4\pi} \right) \right]^{1/2} = 18.18A \end{aligned}$$

The power delivered to the load resistor is

$$P_o = I_{rms}^2 R = 18.18A^2 \times 7.1\Omega = 2346W$$

The load rms voltage, from equation (14.46), is

$$\begin{aligned} V_{rms} &= V \left[\frac{1}{2\pi} \left\{ (\beta - \alpha) - \frac{1}{2} (\sin 2\beta - \sin 2\alpha) \right\} \right]^{1/2} \\ &= 240V \left[\frac{1}{2\pi} \left\{ (3.94 - \frac{1}{6}\pi) - \frac{1}{2} (\sin(2 \times 3.94) - \sin(2 \times \frac{1}{6}\pi)) \right\} \right]^{1/2} = 175.1V \end{aligned}$$

The load current and voltage ripple factors are

$$\begin{aligned} FF_i &= \frac{18.18A}{12.0A} = 1.515 & RF_i &= \sqrt{FF_i^2 - 1} = 1.138 \\ FF_v &= \frac{175.1V}{85V} = 2.06 & RF_v &= \sqrt{FF_v^2 - 1} = 1.8 \end{aligned}$$

The supply power factor is

$$pf = \frac{2346W}{240V \times 18.18A} = 0.54$$

♣

14.2.2 Single-phase, half-wave half-controlled

The half-wave controlled converter waveform in figure 14.4b shows that when $\alpha < \omega t < \pi$, during the positive half of the supply cycle, energy is delivered to the load. But when $\pi < \omega t < 2\pi$, the supply reverses and some energy in the load circuit is returned to the supply. More energy can be retained by the load if the load voltage is prevented from reversing. A load freewheel diode facilitates this objective.

The single-phase half-wave converter can be controlled when a load commutating diode is incorporated as shown in figure 14.6a. The diode will prevent the instantaneous load voltage v_o from going negative, as with the single-phase half-controlled converters shown in figure 14.1.

The load current is defined by equation 13.33 for $\alpha \leq \omega t \leq \pi$ and equation 13.34 for $\pi \leq \omega t \leq 2\pi + \alpha$, namely:

$$L \frac{di}{dt} + Ri = \sqrt{2}V \sin \omega t \quad (A) \quad \alpha \leq \omega t \leq \pi$$

$$L \frac{di}{dt} + Ri = 0 \quad (A) \quad \pi \leq \omega t \leq 2\pi + \alpha$$
(14.68)

At $\omega t = \pi$ the thyristor is line commutated and the load current, and hence freewheel diode current, is of the form of equation 13.36. As shown in figure 14.6b, depending on the delay angle α and R - L load time constant (L/R), the load current may fall to zero, producing discontinuous load current.

The mean load voltage (hence mean output current) for all conduction cases, with a passive L - R load, is

$$V_o = \frac{1}{2\pi} \int_{\alpha}^{\pi} \sqrt{2}V \sin \omega t \, d\omega t$$

$$V_o = \bar{I}_o R = \frac{\sqrt{2}V}{2\pi} (1 + \cos \alpha) \quad (V)$$
(14.69)

which is half the mean voltage for a single-phase half-controlled converter, given by equation (14.1).

The maximum mean output voltage, $\hat{V}_o = \sqrt{2}V / \pi$ (equation 13.29), occurs at $\alpha = 0$. The normalised mean output voltage V_n is

$$V_n = V_o / \hat{V}_o = 1/2(1 + \cos \alpha)$$
(14.70)

The Fourier coefficients of the 1-pulse output voltage are given by equation (14.129). For the single-phase, half-wave, half-controlled case, $p=1$, thus the output voltage harmonics occur at $n=1, 2, 3, \dots$

The rms output voltage for both continuous and discontinuous load current is

$$V_{rms} = \left[\frac{1}{2\pi} \int_{\alpha}^{\pi} (\sqrt{2}V)^2 \sin^2 \omega t \, d\omega t \right]^{1/2}$$

$$= V \left[\frac{1}{2\pi} \{ (\pi - \alpha) + 1/2 \sin 2\alpha \} \right]^{1/2}$$
(14.71)

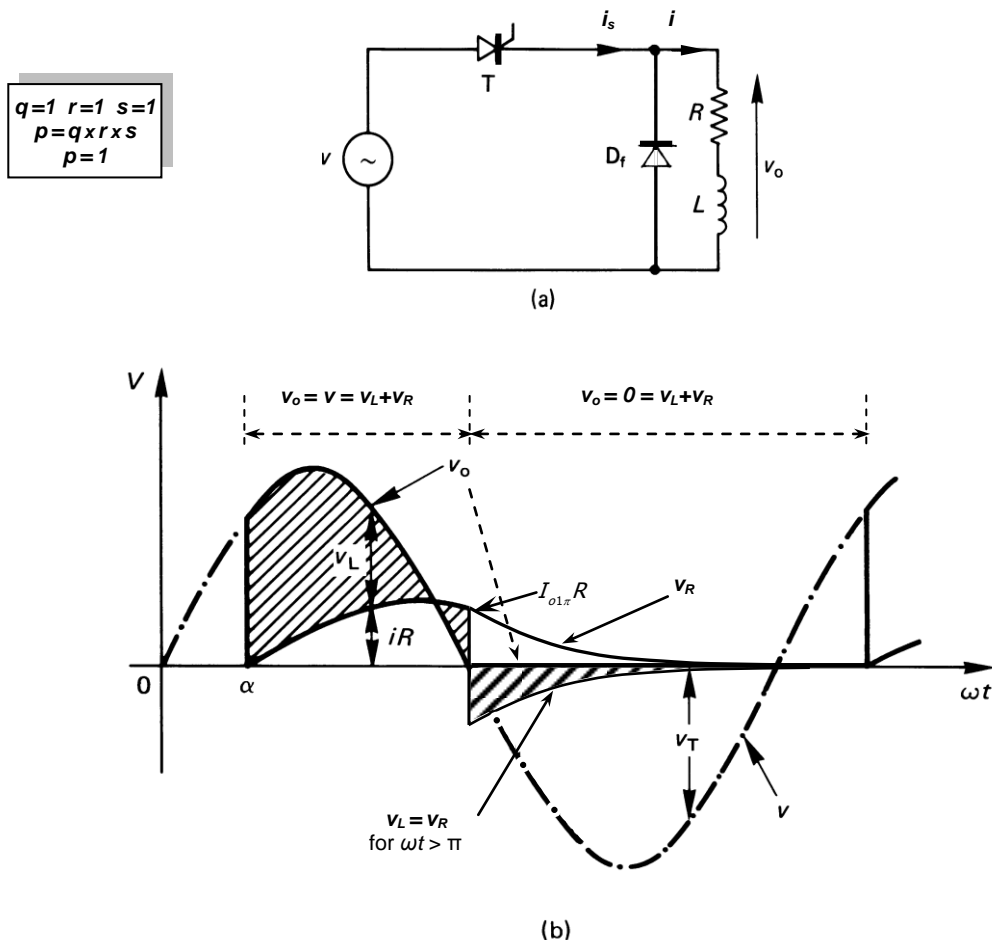

Figure 14.6. Half-wave half-controlled converter:
 (a) circuit diagram and (b) circuit waveforms for an inductive load.

14.2.2i - For **discontinuous conduction** the load current is defined by equation (14.43) during thyristor conduction

$$i(\omega t) = i_s(\omega t) = \frac{\sqrt{2}V}{Z} \times \left(\sin(\omega t - \phi) - \sin(\alpha - \phi) e^{-\omega t + \alpha / \tan \phi} \right) \quad (\text{A})$$

$$\alpha \leq \omega t \leq \pi$$

$$i(\omega t) = i_{Df}(\omega t) = I_{01\pi} e^{-\omega t / \tan \phi} \quad (14.72)$$

$$= \left\{ \frac{\sqrt{2}V}{Z} \times \sin(\phi - \alpha) (1 - e^{-\pi / \tan \phi}) \right\} e^{-\omega t + \pi / \tan \phi} \quad (\text{A})$$

$$\pi \leq \omega t \leq 2\pi + \alpha$$

The average thyristor current is

$$\bar{I}_T = \frac{V}{\sqrt{2}\pi R} \times (\cos^2 \phi + \cos \alpha + \sin \phi \times \sin(\alpha - \phi) \times e^{\alpha - \pi / \tan \phi}) \quad (14.73)$$

while the average freewheel diode current is

$$\bar{I}_{Df} = \bar{I}_o - \bar{I}_T = \frac{V \sin \phi}{\sqrt{2}\pi R} \times (\sin \phi - \sin(\alpha - \phi) \times e^{\alpha - \pi / \tan \phi}) \quad (14.74)$$

14.2.2ii - For **continuous conduction** the load current is defined by

$$i(\omega t) = i_s(\omega t) = \frac{\sqrt{2}V}{Z} \times \left(\sin(\omega t - \phi) + \left(\frac{\sin \phi e^{-\alpha / \tan \phi} - \sin(\alpha - \phi)}{1 - e^{-2\pi / \tan \phi}} \right) e^{-\omega t + \alpha / \tan \phi} \right)$$

$$\alpha \leq \omega t \leq \pi \quad (\text{A})$$

$$i(\omega t) = i_{Df}(\omega t) = I_{01\pi} e^{-\omega t / \tan \phi} \quad (14.75)$$

$$= \left\{ \frac{\sqrt{2}V}{Z} \times \frac{\sin \phi - \sin(\alpha - \phi) e^{-\pi - \alpha / \tan \phi}}{1 - e^{-\pi / \tan \phi}} \right\} e^{-\omega t + \pi / \tan \phi} \quad (\text{A})$$

$$\pi \leq \omega t \leq 2\pi + \alpha$$

For a constant current load I_o the average and rms thyristor currents are

$$\bar{I}_T = \frac{\pi - \alpha}{2\pi} I_o \quad (14.76)$$

$$I_{T_{rms}} = \sqrt{\frac{\pi - \alpha}{2\pi}} I_o \quad (14.77)$$

The advantages (offsetting the dc component in the input) of incorporating a load freewheel diode are

- the input power factor is improved and
- the load waveform is improved (less ripple) giving a better load performance

14.2.3 Single-phase, full-wave controlled rectifier circuit with an R-L load

Full-wave voltage control is possible with the circuits shown in figures 14.7a and b. The circuit in figure 14.7a uses a centre-tapped transformer and two thyristors which experience a reverse bias of twice the supply. At high powers where a transformer may not be applicable, a four-thyristor configuration as in figure 14.7b is suitable. The voltage ratings of the thyristors in figure 14.7b are half those of the devices in figure 14.7a, for a given converter input voltage.

Load voltage and current waveforms are shown in figure 14.7 parts c, d, and e for three different phase control angle conditions.

The load current waveform becomes continuous when the phase control angle α is given by

$$\alpha = \tan^{-1} \omega L / R = \phi \quad (\text{rad}) \quad (14.78)$$

at which angle the output current is a rectified sine wave. For $\alpha > \phi$, discontinuous load current flows as shown in figure 14.7c. At $\alpha = \phi$ the load current becomes continuous as shown in figure 14.7d, whence $\beta = \alpha + \pi$. Further decrease in α , that is $\alpha < \phi$, results in continuous load current that is always greater than zero (no zero current periods), as shown in figure 14.7e.

14.2.3i - $\alpha > \phi$, $\beta - \alpha < \pi$, discontinuous load current

The load current waveform is the same as for the half-wave situation considered in section 14.2.1, given by equation (14.43). That is

$$i(\omega t) = \frac{\sqrt{2}V}{Z} [\sin(\omega t - \phi) - \sin(\alpha - \phi) e^{-(\alpha - \omega t) / \tan \phi}] \quad (\text{A})$$

$$\alpha \leq \omega t < \beta \quad (\text{rad}) \quad (14.79)$$

The mean output voltage for this full-wave circuit will be twice that of the half-wave case in section 14.2.1, given by equation (14.45). That is

$$V_o = \bar{I}_o R = \frac{1}{\pi} \int_{\alpha}^{\beta} \sqrt{2} V \sin \omega t \, d\omega t \tag{14.80}$$

$$= \frac{\sqrt{2} V}{\pi} (\cos \alpha - \cos \beta) \quad (V)$$

where β can be extracted from figure 14.5. For a purely resistive load, $\beta = \pi$. The average output current is given by $\bar{I}_o = V_o / R$ and the average and rms thyristor currents are $1/2 \bar{I}_o$ and $I_{rms} / \sqrt{2}$, respectively.

The rms load voltage is

$$V_{rms} = \left[\frac{1}{\pi} \int_{\alpha}^{\beta} 2V^2 \sin^2 \omega t \, d\omega t \right]^{1/2} \tag{14.81}$$

$$= V \left[\frac{1}{\pi} \{ (\beta - \alpha) - 1/2 (\sin 2\beta - \sin 2\alpha) \} \right]^{1/2}$$

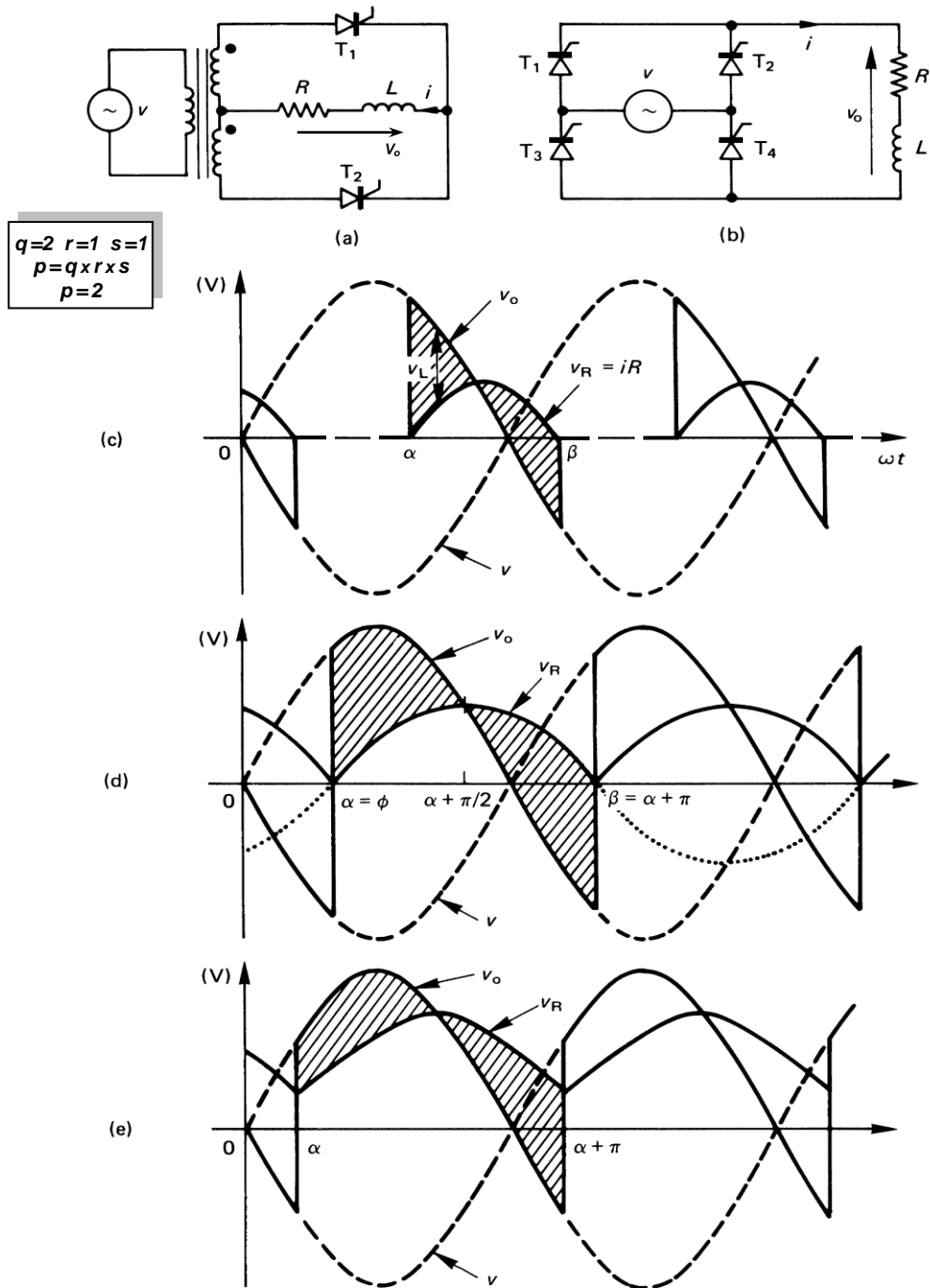

Figure 14.7. Full-wave controlled converter: (a) and (b) circuit diagrams; (c) discontinuous load current; (d) verge of continuous load current, when $a = 0$; and (e) continuous load current.

The rms load current is

$$I_{rms} = \frac{V}{Z} \left[\frac{1}{\pi} \left((\beta - \alpha) - \frac{\sin(\beta - \alpha) \cos(\alpha + \phi + \beta)}{\cos \phi} \right) \right]^{1/2} \quad (14.82)$$

The load power is therefore $P = I_{rms}^2 R$.

14.2.3ii - $\alpha = \phi$, $\beta - \alpha = \pi$, verge of continuous load current

When $\alpha = \phi = \tan^{-1} \omega L / R$, the load current given by equation (14.79) reduces to

$$i(\omega t) = \frac{\sqrt{2}V}{Z} \sin(\omega t - \phi) \quad (A) \quad (14.83)$$

$$\text{for } \phi \leq \omega t \leq \phi + \pi \quad (\text{rad})$$

and the mean output voltage, on reducing equation (14.80) using $\beta = \alpha + \pi$, is given by

$$V_o = \frac{2\sqrt{2}V}{\pi} \cos \alpha \quad (V) \quad (14.84)$$

which is dependent on the load such that $\alpha = \phi = \tan^{-1} \omega L / R$. From equation (14.81), with $\beta - \alpha = \pi$, the rms output voltage is V , $I_{rms} = V/Z$, and power = $VI_{rms} \cos \phi$.

14.2.3iii - $\alpha < \phi$, $\beta - \pi = \alpha$, continuous load current (and also a purely inductive load)

Under a continuous load current conduction condition, a thyristor is still conducting when another is forward-biased and is turned on. The first device is instantaneously reverse-biased by the second device which has been turned on. The first device is commutated and load current is instantaneously transferred to the oncoming device.

The load current is given by

$$i(\omega t) = \frac{\sqrt{2}V}{Z} \left[\sin(\omega t - \phi) - \frac{2 \sin(\alpha - \phi)}{1 - e^{-\pi/\tan \phi}} e^{(\alpha - \omega t)/\tan \phi} \right] \quad (14.85)$$

This equation reduces to equation (14.83) for $\alpha = \phi$ and equation 13.54 for $\alpha = 0$.

The mean output voltage, whence mean output current, are defined by equation (14.84)

$$V_o = \bar{I}_o R = \frac{2\sqrt{2}V}{\pi} \cos \alpha \quad (V)$$

which is uniquely defined by α . The maximum mean output voltage, $\hat{V}_o = 2\sqrt{2}V / \pi$ (equation 13.56), occurs at $\alpha = 0$. Generally, for $\alpha > 1/2\pi$, the average output voltage is negative, (theoretically) resulting in a net energy transfer from the load to the supply.

The normalised mean output voltage V_n is

$$V_n = V_o / \hat{V}_o = \cos \alpha \quad (14.86)$$

The rms output voltage is equal to the rms input supply voltage and is given by

$$V_{rms} = \sqrt{\frac{1}{\pi} \int_{\alpha}^{\pi+\alpha} (\sqrt{2}V)^2 \sin^2 \omega t \, d\omega t} = V \quad (14.87)$$

The ac in the output voltage is

$$V_{ac} = \sqrt{V_{rms}^2 - V_o^2} = V \sqrt{1 + \frac{8}{\pi} \cos^2 \alpha} \quad (14.88)$$

The ac component harmonic magnitudes in the load are given by

$$V_n = \frac{\sqrt{2}V}{2\pi} \times \left(\frac{1}{(n-1)^2} + \frac{1}{(n+1)^2} - \frac{2 \cos 2\alpha}{(n-1)(n+1)} \right) \quad (14.89)$$

for n even, namely $n = 2, 4, 6, \dots$

The load voltage form factor, (thence ripple factor), is

$$FF_v = \frac{\pi}{2\sqrt{2} \cos \alpha} \quad (14.90)$$

The current harmonics are obtained by division of the voltage harmonic by its load impedance at that frequency, that is

$$I_n = \frac{V_n}{Z_n} = \frac{V_n}{\sqrt{R^2 + (n\omega L)^2}} \quad n = 0, 2, 4, 6, \dots \quad (14.91)$$

Integration of equation (14.85), squared, yields the load rms current (or equation 13.55 for $\alpha=0$)

$$I_{rms} = \frac{V}{Z} \left[\frac{1}{\pi} \left\{ \pi + \left(\frac{2 \sin(\alpha - \phi)}{1 - e^{-\pi/\tan \phi}} \right)^2 \tan \phi (1 - e^{-2\pi/\tan \phi}) - 4 \left(\frac{2 \sin(\alpha - \phi)}{1 - e^{-\pi/\tan \phi}} \right) \sin \alpha \sin \phi (1 - e^{-\pi/\tan \phi}) \right\} \right]^{1/2} \quad (14.92)$$

Thyristor average current is $\frac{1}{2} \bar{I}_o$, while thyristor rms current rating is $I_{rms} / \sqrt{2}$. The same thyristor current rating expressions are valid for both continuous and discontinuous load current conditions.

Constant load current

For a highly inductive load, the line current can be considered a square wave of amplitude \bar{I}_o , then the rms input supply current I_{irms} and its fundamental I_{1rms} are

$$I_{irms} = \bar{I}_o \quad \text{and} \quad I_{1rms} = \frac{2\sqrt{2}}{\pi} \bar{I}_o$$

The displacement power factor = $DPF = \cos \alpha$

The distortion factor is

$$DF = \frac{I_{i1}}{I_{irms}} = \frac{2\sqrt{2}}{\pi}$$

The supply power factor is

$$pf = DF \times DPF = \frac{2\sqrt{2}}{\pi} \times \cos \alpha$$

The input current total harmonic distortion is

$$THD = \frac{\sqrt{I_i^2 - I_{i1}^2}}{I_{i1}} = \sqrt{\frac{1 - 8/\pi^2}{8/\pi^2}} = 0.484$$

The harmonic factor or voltage ripple factor for the output voltage is

$$RF_v = \frac{\sqrt{V_{rms}^2 - V_o^2}}{V_o} = \left[\frac{\pi^2}{8} - \cos^2 \alpha \right]^{1/2} \quad (14.93)$$

which has a minimum of 0.483 for $\alpha=0$ and a maximum of 1.11 when $\alpha=\frac{1}{2}\pi$.

Critical load inductance (see figure 14.14)

The critical load inductance, to prevent the load current falling to zero, is given by

$$\frac{\omega L_{crit}}{R} = \frac{\pi}{2 \cos \alpha} \left(\cos \theta + \frac{2}{\pi} \sin \alpha - \frac{2}{\pi} \cos \alpha (\frac{1}{2}\pi + \alpha + \theta) \right) \quad (14.94)$$

for $\alpha \leq \theta$ where

$$\theta = \sin^{-1} \frac{V_o}{\sqrt{2}V} = \sin^{-1} \frac{2 \cos \alpha}{\pi} \quad (14.95)$$

The minimum current occurs at the angle θ , where the mean output voltage V_o equals the instantaneous load voltage, v_o . When the phase delay angle α is greater than the critical angle θ , substituting $\alpha = \theta$ in equation (14.94) gives

$$\frac{\omega L_{crit}}{R} = -\tan \alpha \quad (14.96)$$

14.2.3iv Resistive load, $\beta = \pi$

When the load is purely resistive, that is $L = 0$, the average and rms output voltage and currents are given by substituting $Z=R$ and $\beta = \pi$ in to equations (14.80), (14.81) and (14.82). That is

$$V_o = \bar{I}_o R = 2 \bar{I}_T R = \frac{\sqrt{2}V}{\pi} (\cos \alpha + 1) \quad (V) \quad (14.97)$$

$$V_{rms} = I_{rms} R = I_{o,rms} R = \sqrt{2} I_{T,rms} R = V \left[\frac{1}{\pi} \{ (\pi - \alpha) - \frac{1}{2} \sin 2\alpha \} \right]^{1/2} \quad (14.98)$$

Example 14.3: Controlled full-wave converter – continuous and discontinuous conduction

The fully controlled full-wave, single-phase converter in figure 14.7a has an ac source of 240V rms, 50Hz, and a 10 Ω -50mH series load. If the delay angle is 45°, determine

- the average output voltage and current, hence thyristor mean current
- the rms load voltage and current, hence thyristor rms current and load ripple factors
- the power absorbed by the load and the supply power factor

If the delay angle is increased to 75° determine

- iv. the load current in the time domain
- v. numerically solve the load current equation for β , the current extinction angle
- vi. the load average current and voltage
- vii. the load rms voltage and current hence load ripple factors and power dissipated
- viii. the supply power factor

Solution

The load natural power factor angle is given by

$$\phi = \tan^{-1} \omega L / R = \tan^{-1} (2\pi 50 \times 50\text{mH} / 10\Omega) = 57.5^\circ = 1 \text{ rad}$$

Continuous conduction

Since $\alpha < \phi$ ($45^\circ < 57.5^\circ$), continuous load current flows, which is given by equation (14.85).

$$i(\omega t) = \frac{\sqrt{2} \times 240\text{V}}{18.62\Omega} \left[\sin(\omega t - 1) - \frac{2 \times \sin(1.31 - 1)}{1 - e^{-\pi/1.56}} e^{\{(1.31 - \omega t)/1.56\}} \right]$$

$$= 18.2 \times [\sin(\omega t - 1) - 1.62 \times e^{-\omega t/1.56}]$$

i. The average output current and voltage are given by equation (14.84)

$$V_o = \bar{I}_o R = \frac{2\sqrt{2}V}{\pi} \cos \alpha = \frac{2\sqrt{2}V}{\pi} \cos 45^\circ = 152.8\text{V}$$

$$\bar{I}_o = V_o / R = 152.8\text{V} / 10\Omega = 15.3\text{A}$$

Each thyristor conducts for 180° , hence thyristor mean current is $\frac{1}{2}$ of $15.3\text{A} = 7.65\text{A}$.

ii. The rms load current is determined by harmonic analysis. The voltage harmonics (peak magnitude) are given by equation (14.89)

$$V_n = \frac{\sqrt{2} V}{2\pi} \times \left(\frac{1}{(n-1)^2} + \frac{1}{(n+1)^2} - \frac{2 \cos 2\alpha}{(n-1)(n+1)} \right) \quad \text{for } n = 2, 4, 6, \dots$$

and the corresponding current is given from equation (14.91)

$$I_n = \frac{V_n}{Z_n} = \frac{V_n}{\sqrt{R^2 + (n\omega L)^2}}$$

harmonic n	V_n	$Z_n = \sqrt{R^2 + (n\omega L)^2}$	$I_n = \frac{V_n}{Z_n}$	$\frac{1}{2} I_n^2$
0	(152.79)	10.00	15.28	(233.44)
2	55.65	32.97	1.69	1.42
4	8.16	63.62	0.13	0.01
6	3.03	94.78	0.07	0.00
			$I_o^2 + \sum \frac{1}{2} I_n^2 =$	234.4

The dc output voltage component is given by equation (14.84).

From the calculations in the table, the rms load current is

$$I_{rms} = \sqrt{I_o^2 + \frac{1}{2} \sum I_n^2} = \sqrt{234.4} = 15.3\text{A}$$

Since each thyristor conducts for 180° , the thyristor rms current is $\frac{1}{\sqrt{2}}$ of $15.3\text{A} = 10.8\text{A}$

The rms load voltage is given by equation (14.87), that is 240V .

$$FF_i = \frac{I_{rms}}{\bar{I}_o} = \frac{15.3\text{A}}{15.3\text{A}} = 1.0 \quad RF_i = \sqrt{FF_i^2 - 1} = \sqrt{1.00^2 - 1} = 0.0$$

$$FF_v = \frac{V_{rms}}{V_o} = \frac{240\text{V}}{152.8\text{V}} = 1.57 \quad RF_v = \sqrt{FF_v^2 - 1} = \sqrt{1.57^2 - 1} = 1.21$$

iii. The power absorbed by the load is

$$P_L = I_{rms}^2 R = 15.3\text{A}^2 \times 10\Omega = 2344\text{W}$$

The supply power factor is

$$pf = \frac{P_L}{V_{rms} I_{rms}} = \frac{2344\text{W}}{240\text{V} \times 15.3\text{A}} = 0.64$$

Discontinuous conduction

iv. When the delay angle is increased from 45° to 75° (1.31 rad), discontinuous load current flows since the natural power factor angle $\phi = \tan^{-1} \omega L / R = \tan^{-1} (2\pi 50 \times 50\text{mH} / 10\Omega) = 57.5^\circ \approx 1\text{rad}$ is exceeded. The load current is given by equation (14.79)

$$i(\omega t) = \frac{\sqrt{2} \times 240\text{V}}{18.62\Omega} [\sin(\omega t - 1) - \sin(1.31 - 1) e^{-(1.31 - \omega t)/1.56}]$$

$$= 18.2 \times [\sin(\omega t - 1) - 0.71 \times e^{-\omega t/1.56}]$$

v. Solving the equation in part iv for $\omega t = \beta$ and zero current, that is

$$0 = \sin(\beta - 1) - 0.71 \times e^{-\beta/1.56}$$

gives $\beta = 4.09$ rad or 234.3° .

vi. The average load voltage from equation (14.80) is

$$V_o = \frac{\sqrt{2} \times 240\text{V}}{\pi} (\cos 75^\circ - \cos 234.5^\circ) = 90.8\text{V}$$

$$\bar{I}_o = \frac{V_o}{R} = \frac{90.8\text{V}}{10\Omega} = 9.08\text{A}$$

vii. The rms load voltage is given by equation (14.81)

$$V_{rms} = 240\text{V} \times \left[\frac{1}{\pi} \{ (4.09 - 1.31) - \frac{1}{2}(\sin 8.18 - \sin 2.62) \} \right]^{1/2} = 216.46\text{V}$$

The rms current from equation (14.82) is

$$I_{rms} = \frac{240\text{V}}{18.62\Omega} \times \left[\frac{1}{\pi} \left((4.09 - 1.31) - \frac{\sin(4.09 - 1.31) \times \cos(1.31 + 1 + 4.09)}{\cos 1} \right) \right]^{1/2} = 13.55\text{A}$$

The load voltage and current form and ripple factors are

$$FF_i = \frac{I_{rms}}{\bar{I}_o} = \frac{13.55\text{A}}{9.08\text{A}} = 1.49 \quad RF_i = \sqrt{FF_i^2 - 1} = \sqrt{1.49^2 - 1} = 1.11$$

$$FF_v = \frac{V_{rms}}{V_o} = \frac{216.46\text{V}}{90.8\text{V}} = 2.38 \quad RF_v = \sqrt{FF_v^2 - 1} = \sqrt{2.38^2 - 1} = 2.16$$

The power dissipated in the 10Ω load resistor is

$$P = I_{rms}^2 R = 13.55^2 \times 10\Omega = 1836\text{W}$$

viii. The supply power factor is

$$pf = \frac{P_L}{V_{rms} I_{rms}} = \frac{1836\text{W}}{240\text{V} \times 13.55\text{A}} = 0.56$$

♣

14.2.4 Single-phase, full-wave, fully-controlled circuit with R-L and emf load, E

An emf source and R-L load can be encountered in dc machine modelling. The emf represents the machine speed back emf, defined by $E = k \phi \omega$. DC machines can be controlled by a fully controlled converter configuration as shown in figure 14.8a, where T_1 - T_4 and T_2 - T_3 are triggered alternately.

If in each half sine period the thyristor firing delay angle occurs after the rectified sine supply has fallen below the emf level E , then no load current flows since the bridge thyristors will always be reverse-biased. Thus the zero current firing angle $\hat{\alpha}$ is:

$$\hat{\alpha} = \sin^{-1} (E / \sqrt{2}V) \quad (\text{rad}) \quad \text{for} \quad \frac{1}{2}\pi < \hat{\alpha} < \pi \quad (14.99)$$

where it has been assumed the emf has the polarity shown in figure 14.8a. With discontinuous output current, load current cannot flow until the supply voltage exceeds the back emf E . That is

$$\check{\alpha} = \sin^{-1} (E / \sqrt{2}V) \quad (\text{rad}) \quad \text{for} \quad 0 < \check{\alpha} < \frac{1}{2}\pi \quad (14.100)$$

Load current can always flow with a firing angle defined by

$$\check{\alpha} \leq \alpha \leq \hat{\alpha} \quad (\text{rad}) \quad (14.101)$$

The load circuit current can be evaluated by solving

$$\sqrt{2}V \sin \omega t = L \frac{di}{dt} + Ri + E \quad (\text{V}) \quad (14.102)$$

The load voltage and current ripple are both at twice the supply frequency.

14.2.4i - Discontinuous load current

The load current is given by

$$i(\omega t) = \frac{\sqrt{2}V}{R} \left[\cos \phi \sin(\omega t - \phi) - \frac{E}{\sqrt{2}V} + \left\{ \frac{E}{\sqrt{2}V} - \cos \phi \sin(\alpha - \phi) \right\} e^{\{(\alpha - \omega t)/\tan \phi\}} \right] \quad (14.103)$$

$$\check{\alpha} \leq \omega t \leq \beta < \pi + \alpha \quad (\text{rad})$$

For discontinuous load current conduction, the current extinction angle β , shown on figure 14.8b, is solved by iterative techniques for $i(\omega t = \beta) = 0$ in equation (14.103).

$$\cos \phi \sin(\beta - \phi) - \frac{E}{\sqrt{2}V} + \left\{ \frac{E}{\sqrt{2}V} - \cos \phi \sin(\alpha - \phi) \right\} e^{\{(\alpha - \beta)/\tan \phi\}} = 0 \quad (14.104)$$

The mean output voltage can be obtained from equation (14.80), which is valid for $E = 0$.

In the interval between $\beta \leq \omega t \leq \pi + \alpha$ no current flows and the output voltage is the load back emf, $E = \sqrt{2}V_s \sin \check{\alpha}$. The average output voltage, hence current are given by

$$V_o = \int_{\alpha}^{\beta} \sqrt{2}V \sin \omega t \, d\omega t + \int_{\beta}^{\pi + \alpha} E \, d\omega t$$

$$= \int_{\alpha}^{\beta} \sqrt{2}V \sin \omega t \, d\omega t + \int_{\beta}^{\pi + \alpha} \sqrt{2}V \sin \check{\alpha} \, d\omega t$$

$$V_o = \frac{\sqrt{2}V}{\pi} \left[\cos \alpha - \cos \beta + (\pi + \alpha - \beta) \times \sin \check{\alpha} \right]$$

$$V_o = \frac{\sqrt{2}V}{\pi} \left(\cos \alpha - \cos \beta + (\pi + \alpha - \beta) \frac{E}{\sqrt{2}V} \right) \quad (\text{V}) \quad (14.105)$$

$$0 < \beta - \alpha < \pi \quad (\text{rad})$$

The current extinction angle β is load-dependent, being a function of Z and E , as well as α .

Since $V_o = E + \bar{I}_o R$, the mean load current is given by

$$\bar{I}_o = \frac{V_o - E}{R} = \frac{V_o - \sqrt{2}V \sin \check{\alpha}}{R}$$

$$\bar{I}_o = \frac{V_o - E}{R} = \frac{\sqrt{2}V}{\pi R} \left(\cos \alpha - \cos \beta - \frac{E}{\sqrt{2}V} (\beta - \alpha) \right) \quad (\text{A})$$

$$\bar{I}_o = \frac{\sqrt{2}V}{R} \frac{1}{\pi} \left[\cos \alpha - \cos \beta + (\alpha - \beta) \times \sin \check{\alpha} \right] \quad (14.106)$$

$$0 < \beta - \alpha < \pi \quad (\text{rad})$$

The rms output voltage is given by

$$V_{rms} = \left(V^2 \frac{\beta - \alpha}{\pi} + E^2 \left(1 - \frac{\beta - \alpha}{\pi} \right) - \frac{V^2}{2\pi} (\sin 2\beta - \sin 2\alpha) \right)^{1/2} \quad (\text{V}) \quad (14.107)$$

The rms voltage across the R - L part of the load is given by

$$V_{RL \, rms} = \sqrt{V_{rms}^2 - E^2} \quad (14.108)$$

The total power delivered to the R - L - E load is

$$P_o = I_{rms}^2 R + \bar{I}_o E \quad (14.109)$$

where the rms load current is found by integrating the current in equation (14.103), squared, etc.

The boundary for continuous current conduction is when $i > 0$ at the end of the conduction period when $\omega t = \pi + \alpha$, that is

$$-\sin(\alpha - \phi) - \frac{\sin \check{\alpha}}{\cos \phi} - \left(\sin(\alpha - \phi) - \frac{\sin \check{\alpha}}{\cos \phi} \right) e^{-\pi/\tan \phi} \geq 0$$

That is, continuous conduction occurs when

$$\sin(\alpha - \phi) \geq \frac{\sin \check{\alpha}}{\cos \phi} \times \tanh \left(\frac{-1/2\pi}{\tan \phi} \right) \quad (14.110)$$

With **discontinuous conduction**, the output current is still given by equation (14.61), until the current falls to zero at the extinction angle β . The extinction angle β is found from the boundary condition $i(\omega t) = i(\beta) = 0$, for $\pi + \alpha > \beta > \pi$, in equation(14.61). That is, β is found iteratively from:

$$\sin(\beta - \phi) - \frac{\sin \alpha}{\cos \phi} \left(1 - e^{-\frac{\alpha - \beta}{\tan \phi}} \right) - e^{-\frac{\alpha - \beta}{\tan \phi}} \sin(\alpha - \phi) = 0 \tag{14.111}$$

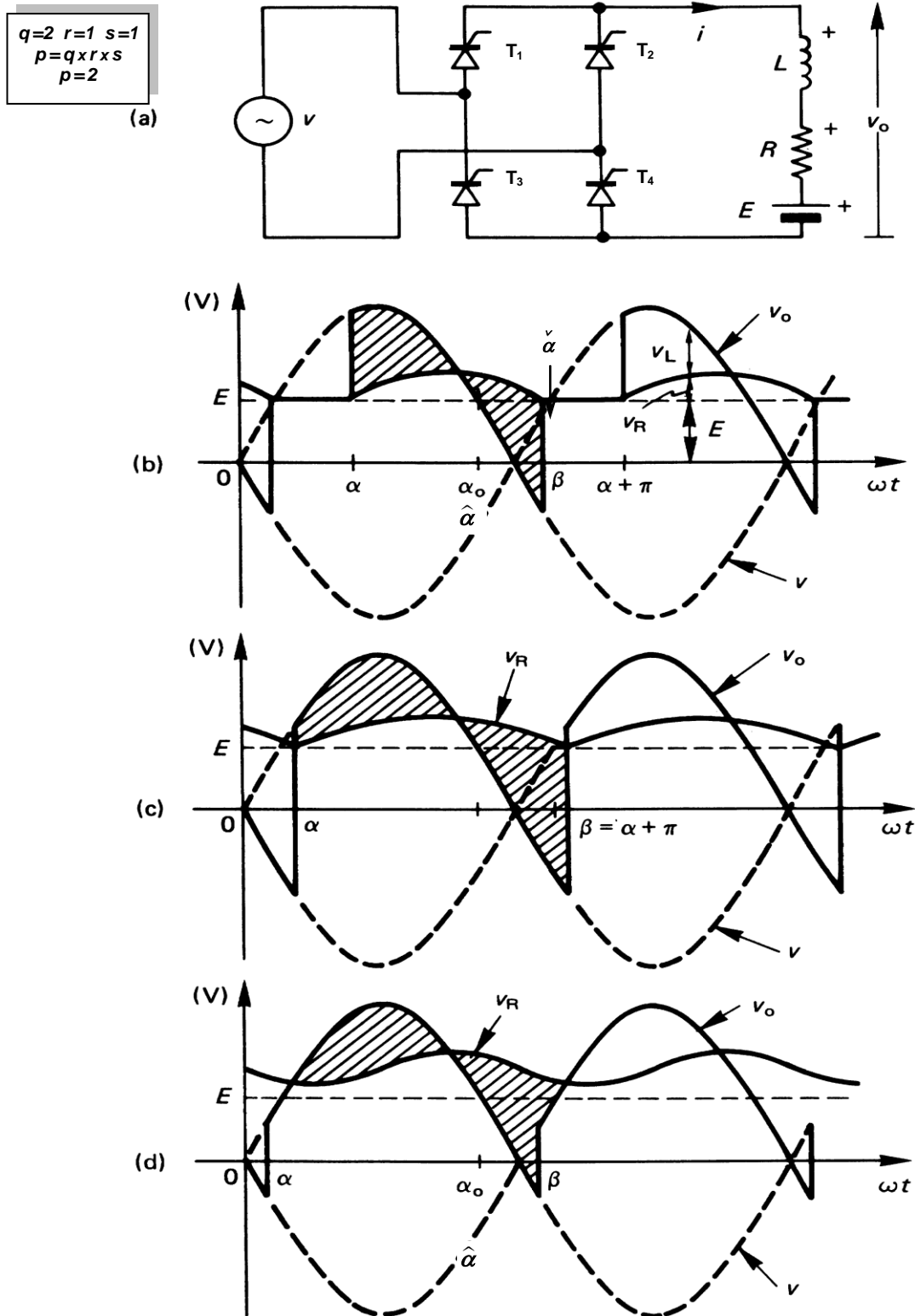

Figure 14.8. A full-wave fully controlled converter with an inductive load which includes an emf source: (a) circuit diagram; (b) voltage waveforms with discontinuous load current; (c) verge of continuous load current; and (d) continuous load current.

Performance aspects of the rectifier such as V_o and \bar{I}_o , can be found in terms of α , β and θ . That is

$$V_o = \frac{1}{\pi} \left[\int_{\alpha}^{\beta} \sqrt{2}V \sin \omega t \, d\omega t + \int_{\beta}^{\pi+\alpha} E \, d\omega t \right]$$

$$= \frac{\sqrt{2}V}{\pi} [\cos \alpha - \cos \beta + (\pi + \alpha - \beta) \sin \theta]$$

$$\bar{I}_o = \frac{V_o - E}{R} = \frac{V_o - E}{Z \cos \phi}$$

$$= \frac{\sqrt{2}V}{\pi Z \cos \phi} [\cos \alpha - \cos \beta + (\pi + \alpha - \beta) \sin \theta]$$

14.2.4ii - Continuous load current

With continuous load current conduction, the load rms voltage is V .

The load current is given by

$$i(\omega t) = \frac{\sqrt{2}V}{Z} \left[\sin(\omega t - \phi) - \frac{E/\sqrt{2}V}{\cos \phi} + 2 \frac{\sin(\alpha - \phi)}{e^{-\pi/\tan \phi} - 1} e^{\{(\alpha - \omega t)/\tan \phi\}} \right]$$

$$= \frac{\sqrt{2}V}{Z} \left[\sin(\omega t - \phi) - \frac{\sin \theta}{\cos \phi} + 2 \frac{\sin(\alpha - \phi)}{e^{-\pi/\tan \phi} - 1} e^{\{(\alpha - \omega t)/\tan \phi\}} \right] \quad (14.112)$$

$$E = \sqrt{2}V \sin \theta \quad \alpha \leq \omega t \leq \pi + \alpha \quad (\text{rad})$$

The periodic minimum current is given by

$$\bar{I} = \frac{\sqrt{2}V}{Z} \sin(\alpha - \phi) \frac{e^{-\pi/\tan \phi} + 1}{e^{-\pi/\tan \phi} - 1} - \frac{E}{R} = \frac{\sqrt{2}V}{Z} \sin(\alpha - \phi) \tanh\left(\frac{1/2\pi}{\tan \phi}\right) - \frac{E}{R} \quad (14.113)$$

For continuous load current conditions, as shown in figures 14.8c and 14.8d, the mean output voltage is given by equation (14.105) with $\beta = \pi - \alpha$

$$V_o = \frac{1}{\pi} \int_{\alpha}^{\pi+\alpha} \sqrt{2}V \sin \omega t \, d\omega t \quad (= E + \bar{I}_o R)$$

$$= \frac{2\sqrt{2}V}{\pi} \cos \alpha \quad (\text{V}) \quad (14.114)$$

$$\left(= \sqrt{2}V \frac{\rho}{\pi} \sin \frac{\pi}{\rho} \cos \alpha \right)$$

The average output voltage is dependent only on the phase delay angle α (independent of E), unlike the mean load current, which is given by

$$\bar{I}_o = \frac{V_o - E}{R} = \frac{\sqrt{2}V}{R} \left(\frac{2}{\pi} \cos \alpha - \frac{E}{\sqrt{2}V} \right) \quad (\text{A}) \quad (14.115)$$

$$= \frac{\sqrt{2}V}{R} \left(\frac{2}{\pi} \cos \alpha - \sin \theta \right)$$

The power absorbed by the emf source in the load is $P = \bar{I}_o E$, while the total power delivered to the R - L - E load is $P_o = I_{rms}^2 R + \bar{I}_o E$.

The output voltage can be expressed as a Fourier series.

$$v_o(t) = V_o + \sqrt{2}V \sum_{n=1}^{\infty} [a_n \cos 2n\omega t + b_n \sin 2n\omega t]$$

$$= \sqrt{2}V \left\{ b_o + \sum_{n=1}^{\infty} [a_n \cos 2n\omega t + b_n \sin 2n\omega t] \right\}$$

$$V_o = \frac{1}{\pi} \int_0^{\pi} v_o(t) \, d\omega t = \frac{1}{\pi} \int_0^{\pi} \sqrt{2}V \sin \omega t \, d\omega t = \sqrt{2}V \frac{2}{\pi} \cos \alpha = \sqrt{2}V \times b_o \quad (14.116)$$

$$a_n = \frac{2}{\pi} \left[\frac{\cos(2n+1)\alpha}{2n+1} - \frac{\cos(2n-1)\alpha}{2n-1} \right]$$

$$b_n = \frac{2}{\pi} \left[\frac{\sin(2n+1)\alpha}{2n+1} - \frac{\sin(2n-1)\alpha}{2n-1} \right] \quad (14.117)$$

Each harmonic current can be found by dividing each harmonic voltage by its associated impedance, that is $i_n = V_n / Z_n$ where $Z_n = \sqrt{R^2 + (2n\omega L)^2}$ and $V_n = V \sqrt{a_n^2 + b_n^2}$. The output current and voltage ripple is at multiples of twice the supply frequency. The output voltage harmonic magnitudes for continuous conduction, given by equation (14.89), are

$$V_n = \frac{\sqrt{2}V}{2\pi} \times \left(\frac{1}{(n-1)^2} + \frac{1}{(n+1)^2} - \frac{2 \cos 2\alpha}{(n-1)(n+1)} \right) \quad \text{for } n = 2, 4, 6, \dots \quad (14.118)$$

The dc component across the R-L (and just the resistor) part of the load is

$$\begin{aligned} V_{oR-L} &= V_o - E \\ &= \frac{2\sqrt{2}V}{\pi} \times \cos \alpha - E \end{aligned} \quad (14.119)$$

The ac component of the output voltage is

$$V_{ac} = \sqrt{V_{rms}^2 - \bar{V}_o^2} = V \sqrt{1 - \left(\frac{2\sqrt{2} \cos \alpha}{\pi} \right)^2} \quad (14.120)$$

and the output voltage form factor is

$$FF_v = \frac{\pi}{2\sqrt{2} \cos \alpha} \quad (14.121)$$

Thyristor average current is $\frac{1}{2}\bar{I}_o$, while thyristor rms current rating is $I_{rms} / \sqrt{2}$. These same two thyristor expressions are valid for both continuous and discontinuous load current conditions.

If the load current is assumed constant and equal to the average current \bar{I}_o then the displacement factor is $\cos \alpha$ and

$$I_{i1rms} = \frac{2\sqrt{2}}{\pi} \bar{I}_o \quad \text{and} \quad I_{irms} = \bar{I}_o$$

Therefore the input distortion factor

$$DF = \frac{I_{i1rms}}{I_{irms}} = \frac{2\sqrt{2}}{\pi}$$

and the input power factor is

$$pf = \frac{\text{actual power}}{\text{apparent power}} = \frac{V_i I_{i1rms} \cos \alpha}{V_i I_{irms}} = \frac{2\sqrt{2}}{\pi} \cos \alpha \quad (\text{lagging})$$

Critical load inductance

From equation (14.113) set to zero (or $i=0$ in equation (14.112)), the boundary between continuous and discontinuous inductor current must satisfy

$$\frac{R}{Z} \sin(\alpha - \phi) \tanh\left(\frac{1/2\pi}{\tan \phi}\right) > \frac{E}{\sqrt{2}V} \quad (> \sin \theta) \quad (14.122)$$

Inversion

If the polarity of the back emf E is reversed as shown in figure 14.9a, waveforms as in parts b and c of figure 14.9 result. The emf supply can provide a forward bias across the bridge thyristors even after the supply polarity has gone negative. The zero current angle $\hat{\alpha}$ now satisfies $\pi < \hat{\alpha} < 3\pi/2$, as given by equation (14.99). Thus load and supply current can flow, even for $\alpha > \pi$.

The relationship between the mean output voltage and current is now given by

$$V_o = -E + \bar{I}_o R = \sqrt{2}V \frac{\rho}{\pi} \sin \frac{\pi}{\rho} \cos \alpha \quad \text{with } \rho = 2 \quad (14.123)$$

That is, the sign of the emf term E in equations (14.99) to (14.122) is appropriately changed to $-E$.

The load current flows from the emf source and if $\alpha > 1/2\pi$, the average load voltage is negative. Power is being delivered to the ac supply from the emf source in the load, which is an energy transfer process called *power inversion*. In general

$$\begin{aligned} 0 < \alpha < 90^\circ &\rightarrow V_o > 0 \quad P_o > 0 \quad i_o > 0 \quad \text{rectification} \\ 90^\circ < \alpha < 180^\circ &\rightarrow V_o < 0 \quad P_o < 0 \quad i_o > 0 \quad \text{inversion} \end{aligned}$$

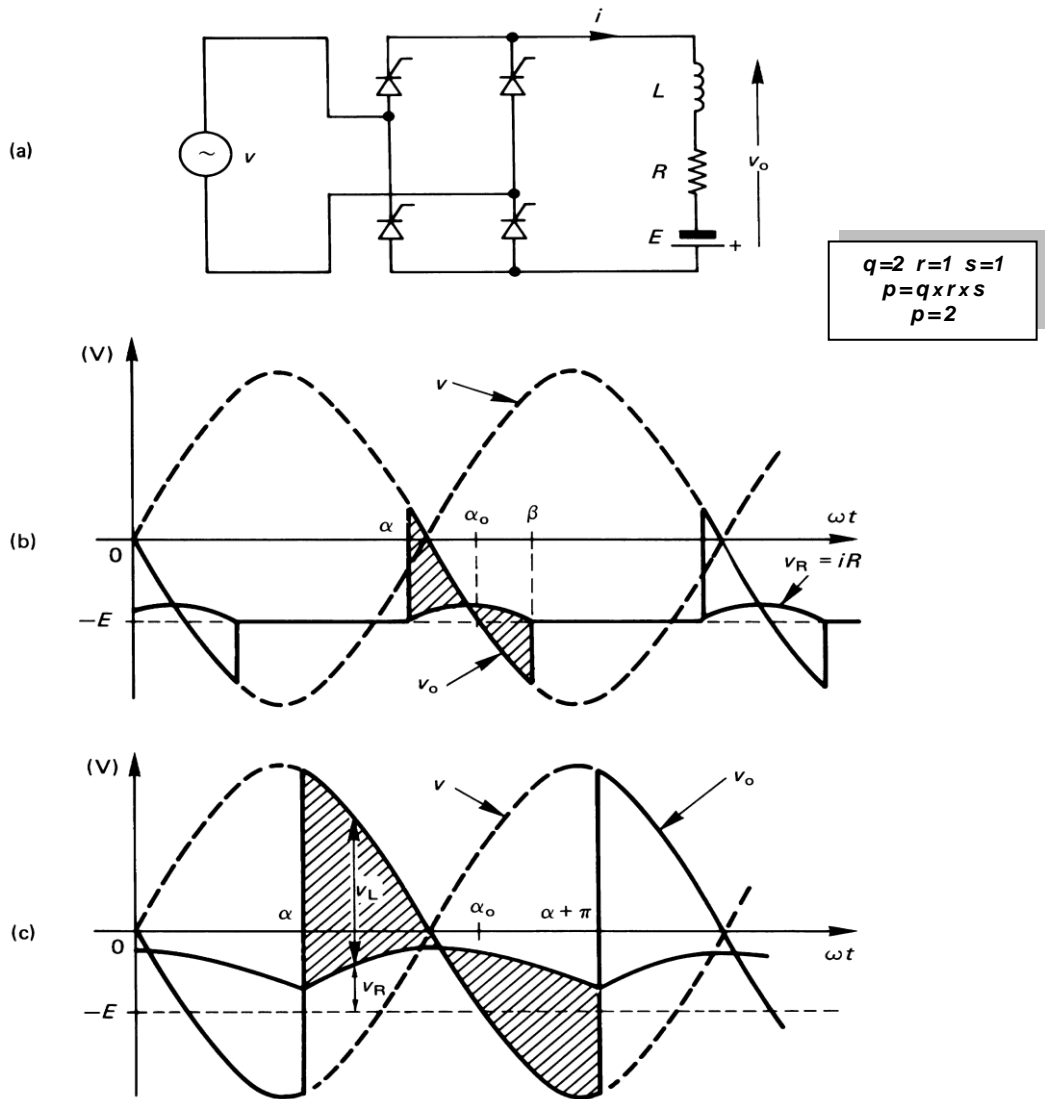

Figure 14.9. A full-wave controlled converter with an inductive load and negative emf source: (a) circuit diagram; (b) voltage waveforms for discontinuous load current; and (c) continuous load current.

Example 14.4: Single-phase, controlled converter – continuous conduction and back emf

The fully controlled full-wave converter in figure 14.7a has a source of 240V rms, 50Hz, and a 10 Ω , 50mH, 50V emf opposing series load (a dc motor). The delay angle is 45°.

Determine

- i. the average output voltage and current
- ii. the rms load voltage and the rms voltage across the R-L part of the load
- iii. the power absorbed by the 50V load back emf
- iv. the rms load current hence power dissipated in the resistive part of the load
- v. the load efficiency, that is percentage of energy into the back emf and power factor
- vi. the load voltage and current form and ripple factors

Solution

From example 14.3, continuous conduction is possible since $\alpha < \phi$ ($45^\circ < 57.5^\circ$).

i. The average output voltage is given by equation (14.114)

$$\begin{aligned}
 V_o &= \frac{2\sqrt{2}V}{\pi} \cos\alpha \\
 &= \frac{2\sqrt{2} \times 240}{\pi} \times \cos 45^\circ = 152.8\text{V}
 \end{aligned}$$

The average current, from equation (14.115) is

$$\bar{I}_o = \frac{V_o - E}{R} = \frac{152.8\text{V} - 50\text{V}}{10\Omega} = 10.28\text{A}$$

ii. From equation (14.87) the rms load voltage is 240V. The rms voltage across the R - L part of the load is

$$\begin{aligned} V_{RLrms} &= \sqrt{V_{rms}^2 - E^2} \\ &= \sqrt{240\text{V}^2 - 50\text{V}^2} = 234.7\text{V} \end{aligned}$$

iii. The power absorbed by the 50V back emf load is

$$P = \bar{I}_o E = 10.28\text{A} \times 50\text{V} = 514\text{W}$$

iv. The R - L load voltage harmonics (which are even) are given by equations (14.118) and (14.119):

$$\begin{aligned} V_{oR-L} &= \frac{2\sqrt{2}V}{\pi} \times \cos \alpha - E \\ V_n &= \frac{\sqrt{2}V}{2\pi} \times \left(\frac{1}{(n-1)^2} + \frac{1}{(n+1)^2} - \frac{2\cos 2\alpha}{(n-1)(n+1)} \right) \quad \text{for } n = 2, 4, 6, \dots \end{aligned}$$

The harmonic currents and voltages are shown in the table to follow.

harmonic n	V_n	$Z_n = \sqrt{R^2 + (n\omega L)^2}$ (Ω)	$I_n = \frac{V_n}{Z_n}$ (A)	$\frac{1}{2}I_n^2$
0	102.79	10.00	10.28	105.66
2	60.02	32.97	1.82	1.66
4	8.16	63.62	0.13	0.01
6	3.26	94.78	0.04	0.00
			$I_o^2 + \sum \frac{1}{2}I_n^2 =$	107.33

From the table the rms load current is given by

$$I_{rms} = \sqrt{I_o^2 + \frac{1}{2}\sum I_n^2} = \sqrt{107.33} = 10.36\text{A}$$

The power absorbed by the 10 Ω load resistor is

$$P_L = I_{rms}^2 R = 10.36\text{A}^2 \times 10\Omega = 1073.3\text{W}$$

v. The load efficiency, that is, percentage energy into the back emf E is

$$\eta = \frac{514\text{W}}{514\text{W} + 1073.3\text{W}} \times 100\% = 32.4\%$$

The power factor is

$$pf = \frac{P_L}{V_{rms} I_{rms}} = \frac{514\text{W} + 1073.3\text{W}}{240\text{V} \times 10.36\text{A}} = 0.64$$

vi. The output performance factors are

$$\begin{aligned} FF_i &= \frac{I_{rms}}{\bar{I}_o} = \frac{10.36\text{A}}{10.28\text{A}} = 1.008 & RF_i &= \sqrt{FF_i^2 - 1} = \sqrt{1.008^2 - 1} = 0.125 \\ FF_v &= \frac{V_{rms}}{V_o} = \frac{240\text{V}}{152.8\text{V}} = 1.57 & RF_v &= \sqrt{FF_v^2 - 1} = \sqrt{1.57^2 - 1} = 1.211 \end{aligned}$$

Note that the voltage form factor (hence voltage ripple factor) agrees with that obtained by substitution into equation (14.121), 1.57.



Example 14.5: Controlled converter – constant load current, back emf, and overlap

The fully controlled single-phase full-wave converter in figure 14.7a has a source of 230V rms, 50Hz, and a series load composed of $\frac{1}{2}\Omega$, infinite inductance, 150V emf non-opposing. If the average load current is to be 200A, calculate the delay angle assuming the converter is operating in the inversion mode, taking into account 1mH of commutation inductance.

Solution

The mean load current is

$$\bar{I}_o = \frac{V_o(\alpha) - E}{R}$$

$$200\text{A} = \frac{V_o(\alpha) - (-150\text{V})}{\frac{1}{2}\Omega}$$

which implies a load voltage $V_o(\alpha) = -50\text{V}$.

The output voltage is given by equation (14.84) $V_o = \frac{2\sqrt{2}V}{\pi} \cos \alpha$. Commutation of current from one rectifier to the other takes a finite time. The effect of commutation inductance is to reduce the output voltage, thus according to equation (14.198), the output voltage becomes

$$V_o = \frac{\sqrt{2}V}{\pi/n} \sin \frac{\pi}{n} \cos \alpha - n\omega L_c I_o / 2\pi \quad \text{where } n = 2$$

$$-50\text{V} = \frac{\sqrt{2} \times 230\text{V}}{\pi/2} \times \cos \alpha - 2 \times 50\text{Hz} \times 1\text{mH} \times 200\text{A}$$

$$= 207\text{V} \times \cos \alpha - 20\text{V}$$

which yields $\alpha = 98.3^\circ$. The commutation overlap causes the output voltage to reduce to zero volts and the overlap period γ is given by equation (14.199)

$$I_o = \frac{\sqrt{2}V}{2\pi f L_c} (\cos \alpha - \cos(\gamma + \alpha))$$

$$200\text{A} = \frac{\sqrt{2} \times 230\text{V}}{2\pi \times 50\text{Hz} \times 1\text{mH}} (\cos 98.3^\circ - \cos(\gamma + 98.3^\circ))$$

This gives an overlap angle of $\gamma = 11.2^\circ$.

♣

14.3 Three-phase half-controlled converter

Compared with single phase converters, three phase ac to dc converters operate from a 3-phase ac supply voltage. They are characterized by

- higher dc output voltage
- higher dc output power and
- higher output voltage ripple frequency

Output filtering requirements are simplified for smoothing the load voltage and load current.

Assuming three phase voltages

$$V_{an} = \vec{V}_a = V \angle 0^\circ = V \sin \omega t$$

$$V_{bn} = \vec{V}_b = V \angle -120^\circ = V \sin(\omega t - 120^\circ)$$

$$V_{cn} = \vec{V}_c = V \angle +120^\circ = V \sin(\omega t + 120^\circ)$$

Then the line to line voltage phase a to phase b is

$$\vec{V}_{ab} = \vec{V}_a - \vec{V}_b$$

$$= \sqrt{2}V \sin \omega t - \sqrt{2}V \sin(\omega t - 120^\circ)$$

$$= \sqrt{2}V \sin \omega t - \frac{1}{2}\sqrt{2}V \sin \omega t - \frac{\sqrt{3}}{2}\sqrt{2}V \cos \omega t$$

$$= \sqrt{3} \sqrt{2}V \sin(\omega t + 30^\circ) = \sqrt{3} \sqrt{2}V \sin(\omega t + \frac{1}{6}\pi)$$

$$\begin{aligned}
 V_o &= \sqrt{2} V \frac{3\sqrt{3}}{2\pi} (1 + \cos \alpha) = \sqrt{2} V_L \frac{3}{2\pi} (1 + \cos \alpha) \\
 &= 2.34 V (1 + \cos \alpha) \quad (\text{V}) \\
 & \quad \quad \quad 0 \leq \alpha \leq \frac{2}{3}\pi \quad (\text{rad})
 \end{aligned} \tag{14.125}$$

$$V_o = \bar{I}_o R$$

At $\alpha = 0$, $\hat{V}_o = \sqrt{2} V \frac{3\sqrt{3}}{2\pi} = 1.35 V_L$, as in equation (13.103). The normalised mean output voltage V_n is

$$V_n = V_o / \hat{V}_o = \frac{1}{2}(1 + \cos \alpha) \tag{14.126}$$

The diodes prevent any negative output, hence inversion cannot occur. Typical output voltage and current waveforms for a highly inductive load (constant current) are shown in figure 14.10b.

14.3i - $\alpha \leq \frac{1}{3}\pi$

When the delay angle is less than $\frac{1}{3}\pi$ the output waveform contains six pulses per cycle, of alternating controlled and uncontrolled phases, as shown in figure 14.10b. The output current is always continuous (even for a resistive load) since no output voltage zeros occur. The rms output voltage is given by

$$\begin{aligned}
 V_{rms} &= \sqrt{\frac{3}{2\pi} \left\{ \int_{\alpha+\pi/3}^{2\pi/3} (\sqrt{2} V_L)^2 \sin^2 \omega t \, d\omega t + \int_{\pi/3}^{\alpha+2\pi/3} (\sqrt{2} V_L)^2 \sin^2 \omega t \, d\omega t \right\}} \\
 &= V_L \left(1 + \frac{3\sqrt{3}}{4\pi} (1 + \cos 2\alpha) \right)^{1/2}
 \end{aligned} \tag{14.127}$$

$$\text{for } 0 \leq \alpha \leq \pi/3$$

14.3ii - $\alpha \geq \frac{1}{3}\pi$

For delay angles greater than $\frac{1}{3}\pi$ the output voltage waveform is made up of three controlled pulses per cycle, as shown in figure 14.10c. Although output voltage zeros result, continuous load current can flow through a diode and the conducting thyristor, or through the commutating diode if employed. The rms output voltage is given by

$$\begin{aligned}
 V_{rms} &= \sqrt{\frac{3}{2\pi} \int_{\alpha}^{\pi} (\sqrt{2} V_L)^2 \sin^2 \omega t \, d\omega t} \\
 &= V_L \left(\frac{3}{2\pi} (\pi - \alpha + \frac{1}{2} \sin 2\alpha) \right)^{1/2}
 \end{aligned} \tag{14.128}$$

$$\text{for } \alpha \geq \pi/3$$

The Fourier coefficients of the p -pulse output voltage are given by

$$\begin{aligned}
 a_n &= \frac{\sqrt{2} V}{2\pi/p} \left[\frac{-2}{n^2 - 1} - \frac{\cos(n+1)\alpha}{n+1} + \frac{\cos(n-1)\alpha}{n-1} \right] \\
 b_n &= \frac{\sqrt{2} V}{2\pi/p} \left[\frac{\sin(n+1)\alpha}{n+1} - \frac{\sin(n-1)\alpha}{n-1} \right]
 \end{aligned} \tag{14.129}$$

where $n = mp$ and $m = 1, 2, 3, \dots$. For the three-phase, full-wave, half-controlled case, $p = 6$, thus the output voltage harmonics occur at $n = 6, 12, \dots$. The three phase supply factors are

$$\text{Displacement Factor} = \cos \frac{1}{2}\alpha$$

$$\text{Distortion factor} = \frac{I_{a1}}{I_a} = \frac{\sqrt{3}\sqrt{2}I_o \cos \frac{1}{2}\alpha}{I_o \sqrt{\frac{\pi - \alpha}{\pi}}} = \frac{\sqrt{3}\sqrt{2}}{\sqrt{\pi(\pi - \alpha)}} \cos \frac{1}{2}\alpha$$

$$\text{Power Factor} = \text{Distortion factor} \times \text{Displacement Factor}$$

$$= \frac{\sqrt{3}}{\sqrt{2\pi(\pi - \alpha)}} (1 + \cos \alpha)$$

The time domain solutions for the rectified output current, assuming an inductive load with a load back emf E , for the three periods are

For the interval $0 < \omega t < \alpha + \frac{1}{3}\pi$

$$i_o(\omega t) = Ie^{\frac{\omega t}{\tan \phi}} + \frac{\sqrt{3}\sqrt{2}V}{Z} \left[\sin(\omega t + \frac{1}{3}\pi - \phi) - \frac{\sin \theta}{\cos \phi} \right] \tag{14.130}$$

where $\tan \phi = \omega L/R$ $Z = \sqrt{R^2 + \omega^2 L^2}$ $E = \sqrt{2}\sqrt{3}V \sin \theta$ and

$$I = \frac{\sqrt{2}\sqrt{3}V}{Z} \frac{e^{\frac{\alpha - \frac{1}{2}\pi}{\tan \phi}} \sin(\phi - \alpha) + \sin \phi}{1 - e^{\frac{2\pi}{3 \tan \phi}}}$$

For the interval $\alpha + \frac{1}{3}\pi < \omega t < \frac{2}{3}\pi$

$$i_o(\omega t) = \frac{\sqrt{3}\sqrt{2}V}{Z} \left[\left\{ e^{\frac{\omega t - \alpha - \frac{1}{2}\pi}{\tan \phi}} + \frac{e^{\frac{\omega t - \alpha + \frac{1}{2}\pi}{\tan \phi}}}{1 - e^{\frac{2\pi}{3 \tan \phi}}} \right\} \sin(\phi - \alpha) + \frac{e^{\frac{\omega t}{\tan \phi}} \sin \phi}{1 - e^{\frac{2\pi}{3 \tan \phi}}} + \sin(\omega t - \phi) - \frac{\sin \theta}{\cos \phi} \right] \quad (14.131)$$

14.4 Three-phase, controlled thyristor converter circuits

The three-phase line input voltages (14.124) are:

$$\begin{aligned} v_{ab} &= V_{\max} \sin(\omega t + \frac{1}{6}\pi) \\ v_{bc} &= V_{\max} \sin(\omega t - \frac{1}{2}\pi) \\ v_{ca} &= V_{\max} \sin(\omega t + \frac{1}{2}\pi) \end{aligned} \quad (14.132)$$

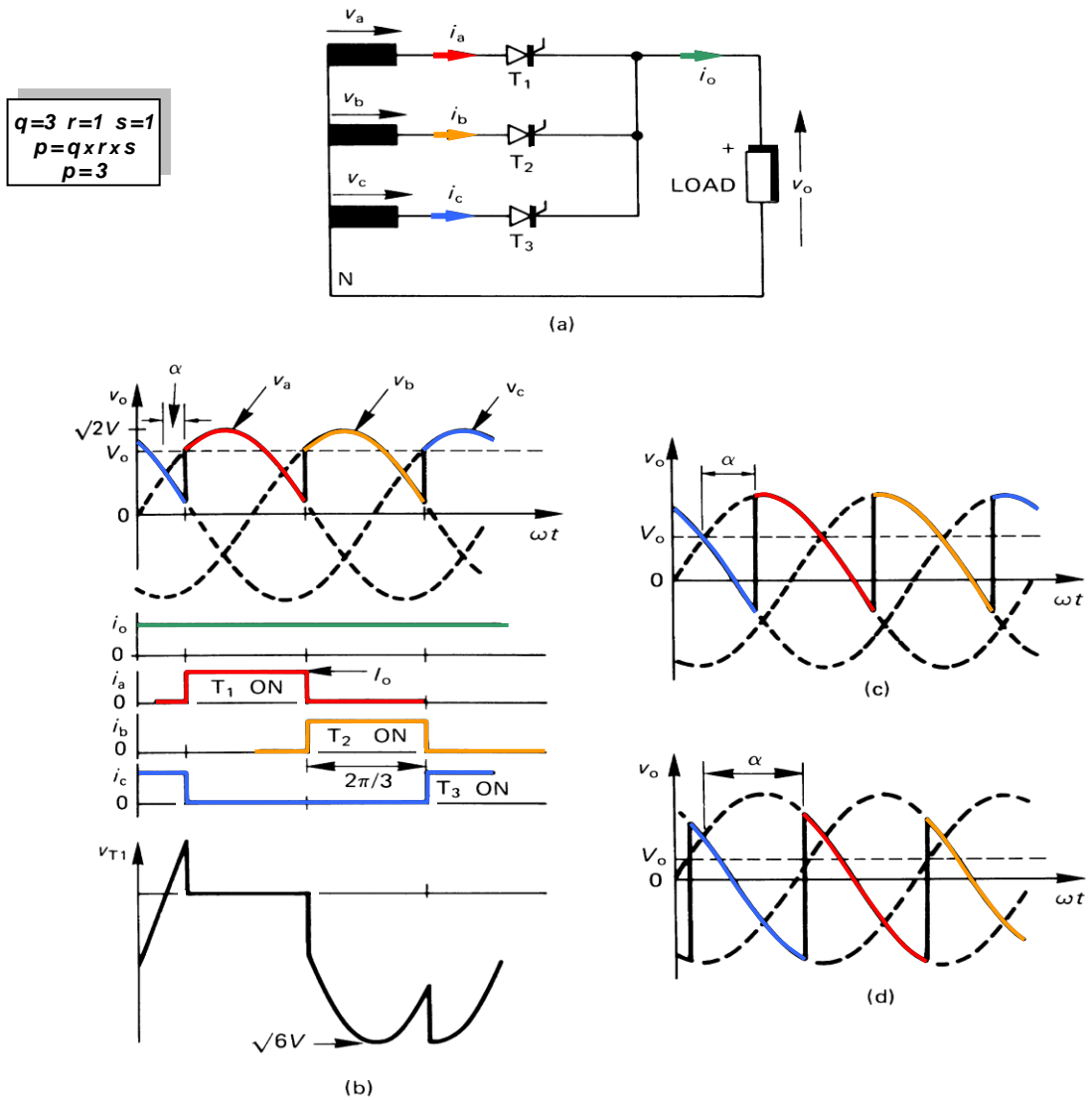

Figure 14.11. Three-phase half-wave controlled converter: (a) circuit connection; (b) voltage and current waveforms for a small firing delay angle α ; (c) and (d) load voltage waveforms for progressively larger delay angles.

14.4.1 Three-phase, fully-controlled, half-wave circuit with an inductive load

When the diodes in the circuit of figure 13.11 are replaced by thyristors, as in figure 14.11a, a three-phase fully controlled half-wave converter results. The output voltage is controlled by the delay angle α . This angle is specified from the thyristor commutation angle, which is the earliest point the associated thyristor becomes forward-biased, as shown in parts b, c, and d of figure 14.11. (The reference is not the phase zero voltage cross-over point). The thyristor with the highest instantaneous anode potential will conduct when fired and in turning on will reverse bias and turn off any previously conducting thyristor. The output voltage ripple is three times the supply frequency and the supply currents contain dc components. Each phase progressively conducts for periods of $\frac{2}{3}\pi$, displaced by α , as shown in figure 14.11b.

The mean output voltage for an n -phase half-wave controlled converter is given by (see example 14.9)

$$\begin{aligned} V_o &= \frac{\sqrt{2}V}{2\pi/n} \int_{\alpha-\pi/n}^{\alpha+\pi/n} \cos \omega t \, d\omega t \\ &= \sqrt{2}V \frac{\sin(\pi/n)}{\pi/n} \cos \alpha \quad (\text{V}) \end{aligned} \quad (14.133)$$

which for the three-phase circuit considered with **continuous or discontinuous (R) load current** gives

$$V_o = \bar{I}_o R = \frac{3\sqrt{3}}{2\pi} \sqrt{2}V \cos \alpha = 1.17V \cos \alpha \quad 0 \leq \alpha \leq \pi/6 \quad (14.134)$$

For **discontinuous conduction**, and a resistive load, the mean output voltage is

$$V_o = \bar{I}_o R = \frac{3}{2\pi} \sqrt{2}V (1 + \cos(\alpha + \pi/6)) \quad \pi/6 \leq \alpha \leq 5\pi/6 \quad (14.135)$$

The mean output voltage is zero for $\alpha = \frac{1}{2}\pi$. For $0 < \alpha < \frac{1}{6}\pi$, the instantaneous output voltage is always greater than zero. Negative average output voltage occurs when $\alpha > \frac{1}{2}\pi$ as shown in figure 14.11d. Since the load current direction is unchanged, for $\alpha > \frac{1}{2}\pi$, power reversal occurs, with energy feeding from the load into the ac supply. Power inversion assumes a load with an emf to assist the current flow, as in figure 14.9. If $\alpha > \pi$ no reverse bias exists for natural commutation and continuous load current will freewheel.

The maximum mean output voltage $\hat{V}_o = \sqrt{2}V \frac{3\sqrt{3}}{2\pi}$ occurs at $\alpha = 0$. The normalised mean output voltage V_n is

$$V_n = V_o / \hat{V}_o = \cos \alpha \quad (14.136)$$

With an R - L load, at $V_o = 0$, the load current falls to zero. Thus for $\alpha > \frac{1}{2}\pi$, continuous load current does not flow for an R - L load.

The rms output voltage (for inductive and resistive loads) is given by

$$\begin{aligned} V_{rms} &= \sqrt{\frac{3}{2\pi} \int_{\alpha-\pi/3}^{\alpha+\pi/3} (\sqrt{2}V)^2 \sin^2(\omega t) \, d\omega t} \\ &= V \left(1 + \frac{3\sqrt{3}}{4\pi} \sin 2\alpha \right)^{1/2} \quad 0 \leq \alpha \leq \pi/6 \\ V_{rms} &= \sqrt{\frac{3}{2\pi} \int_{\pi/6+\alpha}^{\pi} (\sqrt{2}V \sin \omega t)^2 \, d\omega t} \\ &= \sqrt{3} \sqrt{2}V \sqrt{\frac{5}{24} - \frac{\alpha}{4\pi} + \frac{1}{8\pi} \sin(\pi/3 + 2\alpha)} \quad \pi/6 \leq \alpha \leq 5\pi/6 \end{aligned} \quad (14.137)$$

From equations (14.134) and (14.137), the ac in the output voltage is

$$V_{ac} = \sqrt{V_{rms}^2 - V_o^2} = V \left(1 + \frac{3\sqrt{3}}{4\pi} \sin 2\alpha - \frac{9}{\pi} \cos^2 \alpha \right)^{1/2} \quad (14.138)$$

The output voltage distortion ripple factor is

$$RF_v = \sqrt{\frac{2\pi^2}{27} + \frac{\sqrt{3}\pi}{18} \sin 2\alpha - \cos^2 \alpha} \quad (\text{min(at } \alpha=0) = 0.173; \text{ max(at } \alpha=\frac{1}{2}\pi) = 0.66) \quad (14.139)$$

Equation (14.134) holds for a six phase with connected neutral controlled converter, over $0 < \omega t < \frac{2}{3}\pi$.

14.4.1i Three Phase Half Wave Controlled Rectifier with DC Load Current

For a constant current load I_{dc} , each thyristor is forced to conduct for 120° once forward biased, then triggered with a delay α . The phase current Fourier component are given by

$$b_n = \frac{2}{\pi} \int_0^{2\pi/3} I_{dc} \sin(n\omega t) d\omega t = \frac{2I_{dc}}{\pi n} \left(1 - \cos \frac{2n\pi}{3}\right)$$

where

$$b_n = \frac{2I_{dc}}{n\pi} \times \frac{3}{2} \quad \text{for } n=1, 2, 4, 5, 7, 8, 10, \dots$$

$$b_n = 0 \quad \text{for } n=3, 6, 9, 12, \dots \text{(triplens)}$$

Hence the phase current is

$$i_p(\omega t) = \frac{3I_{dc}}{\pi} \left[\sin \omega t + \frac{1}{2} \sin 2\omega t + \frac{1}{4} \sin 4\omega t + \frac{1}{5} \sin 5\omega t + \frac{1}{7} \sin 7\omega t + \dots \right]$$

For a constant current load I_{dc} , each thyristor is forced to conduct for 120° once forward biased, then triggered with a delay α . The phase current Fourier component are given by

$$b_n = \frac{2}{\pi} \int_0^{2\pi/3} I_{dc} \sin(n\omega t) d\omega t = \frac{2I_{dc}}{\pi n} \left(1 - \cos \frac{2n\pi}{3}\right)$$

where

$$b_n = \frac{2I_{dc}}{n\pi} \times \frac{3}{2} \quad \text{for } n=1, 2, 4, 5, 7, 8, 10, \dots$$

$$b_n = 0 \quad \text{for } n=3, 6, 9, 12, \dots \text{(triplens)}$$

Hence the phase current is

$$i_p(\omega t) = \frac{3I_{dc}}{\pi} \left[\sin \omega t + \frac{1}{2} \sin 2\omega t + \frac{1}{4} \sin 4\omega t + \frac{1}{5} \sin 5\omega t + \frac{1}{7} \sin 7\omega t + \dots \right]$$

The rms phase current I_p is

$$I_p = \sqrt{\frac{2}{3}} I_{dc}$$

The supply current THD is

$$THD_{ip} = \sqrt{\frac{I_p^2 - I_{p1}^2}{I_{p1}^2}} = \sqrt{\frac{I_p^2}{I_{p1}^2} - 1} = \sqrt{\frac{\left(\frac{\sqrt{2}}{\sqrt{3}} I_{dc}\right)^2}{\left(\frac{1}{\sqrt{2}} \frac{3I_{dc}}{\pi}\right)^2} - 1} = 68\%$$

or based only on the relative pu harmonic component magnitudes

$$THD_{ip} = \sqrt{\frac{1^2}{2} + \frac{1^2}{4} + \frac{1^2}{5} + \frac{1^2}{7} + \frac{1^2}{8} + \dots} \cong 68\%$$

The input current power factor pf, lagging, which is independent of the dc load current, is given by

$$\begin{aligned} pf &= \frac{I_{p1}}{I_p} \cos\left(\alpha + \frac{1}{6}\pi\right) = \frac{\frac{1}{\sqrt{2}} \frac{3I_{dc}}{\pi}}{\frac{\sqrt{2}}{\sqrt{3}} I_{dc}} \cos\left(\alpha + \frac{1}{6}\pi\right) \\ &= \frac{3\sqrt{3}}{2\pi} \cos\left(\alpha + \frac{1}{6}\pi\right) \end{aligned}$$

Example 14.6: Three-phase half-wave controlled rectifier, with resistive load

Three phase half-wave controlled rectifier is connected to 415Vac three phase supply via a delta way 415/460V transformer. The rectifier load is 10Ω and delay angle is $\alpha=25^\circ$, then increased to $\alpha=60^\circ$. Calculate the PIV of the thyristors and the rectification efficiency for each delay angle.

Solution

i. The thyristor PIV is

$$PIV = \sqrt{2} V_{LL} = \sqrt{2} \times 460 = 650.54 \text{ V}$$

ii. Rectification efficiency at $\alpha=25^\circ$

$$V_{dc} = \frac{3\sqrt{3}}{2\pi} \sqrt{2} V \cos \alpha = \frac{3}{\sqrt{2\pi}} V_{LL} \cos \alpha = \frac{3}{\sqrt{2\pi}} 460 \times \cos 25^\circ = 281.5 \text{ V}$$

$$V_{rms} = \sqrt{2} V_{LL} \sqrt{\frac{1}{6} + \frac{\sqrt{3}}{8\pi} \cos 2\alpha} = \sqrt{2} 460 \sqrt{\frac{1}{6} + \frac{\sqrt{3}}{8\pi} \cos(2 \times 25)} = 298.8 \text{ V}$$

The rectification efficiency with a 25° delay angle (and since the load is purely resistive) is

$$\eta = \frac{V_{dc} I_{dc}}{V_{rms} I_{rms}} \times 100 = \frac{V_{dc}^2 / R}{V_{rms}^2 / R} \times 100 = \frac{V_{dc}^2}{V_{rms}^2} \times 100 = 88.75\%$$

iii. Rectification efficiency at $\alpha=60^\circ$

$$V_{dc} = \frac{3\sqrt{2}V}{2\pi} \left[1 + \cos\left(\frac{\pi}{6} + \alpha\right) \right] = \frac{3\left(\frac{\sqrt{2}}{\sqrt{3}}\right) \times 460}{2\pi} \left[1 + \cos\left(\frac{\pi}{6} + \frac{\pi}{3}\right) \right] = 179.33 \text{ V}$$

$$V_{rms} = V_{LL} \sqrt{\frac{5}{24} - \frac{\alpha}{4\pi} + \frac{1}{8\pi} \sin(\pi/3 + 2\alpha)} = 230 \text{ V}$$

The rectification efficiency with a 60° delay angle is

$$\eta = \frac{V_{dc} I_{dc}}{V_{rms} I_{rms}} \times 100 = \frac{V_{dc}^2}{V_{rms}^2} \times 100 = 60.79\%$$

For a purely resistive load, the rectification efficiency is independent of load resistance and transformer turns ratio, but decreases with increasing delay angle.



14.4.2 Three-phase, half-wave converter with freewheel diode

Figure 14.12 shows a three-phase, half-wave controlled rectifier converter circuit with a load freewheel diode, D_f . This diode prevents the load voltage from going negative, thus inversion is not possible.

14.4.2i - $\alpha < \pi/6$. The output is as in figure 14.11b, with no voltage zeros occurring. The mean output voltage (and current) is given by equation (14.134), that is

$$V_o = \bar{I}_o R = \frac{3\sqrt{3}}{2\pi} \sqrt{2} V \cos \alpha = 1.17V \cos \alpha \quad (\text{V}) \quad 0 \leq \alpha \leq \pi/6 \quad (\text{rad}) \quad (14.140)$$

The maximum mean output $V_o = \sqrt{2} V 3\sqrt{3}/2\pi$ occurs at $\alpha = 0$. The normalised mean output voltage, V_n is given by

$$V_n = V_o / \hat{V}_o = \cos \alpha \quad (14.141)$$

The Fourier coefficients of the 3-pulse output voltage are given by (14.129). For the three-phase, half-wave, half-controlled case, $p=3$, thus the output voltage harmonics occur at $n=3, 6, 9, \dots$

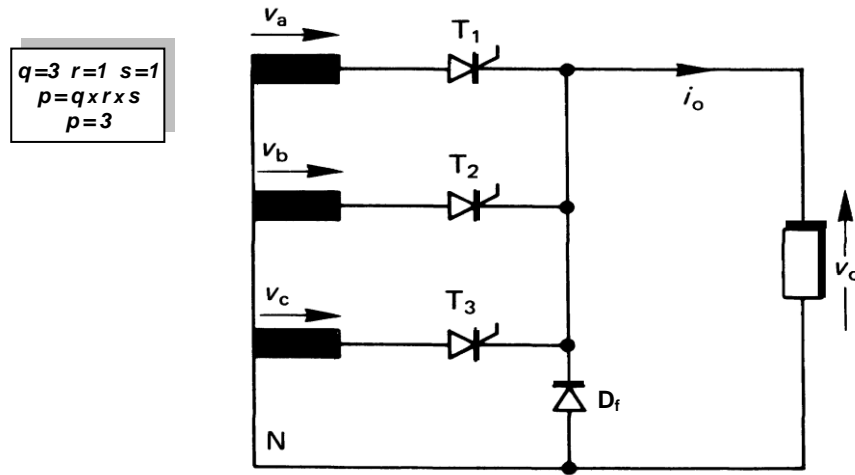

Figure 14.12. A half-wave fully controlled three-phase converter with a load freewheel diode.

14.4.2ii - $\alpha > \pi/6$. Because of the freewheel diode, voltage zeros occur and the negative portions in the waveforms in parts c and d of figure 14.11 do not occur. The mean output voltage is given by

$$V_o = \bar{I}_o R = \frac{\sqrt{2}V}{2\pi/3} \int_{\alpha-\pi/6}^{\pi} \sin \omega t \, d\omega t$$

$$= \frac{\sqrt{2}V}{2\pi/3} (1 + \cos(\alpha + \pi/6)) \quad (\text{V}) \quad (14.142)$$

$$\pi/6 \leq \alpha \leq 5\pi/6$$

The normalised mean output voltage V_n is

$$V_n = V_o / \hat{V}_o = [1 + \cos(\alpha + \pi/6)] / \sqrt{3} \quad (14.143)$$

The average load current (with an emf E in the load) is given by

$$\bar{I}_o = \frac{V_o - E}{R} \quad (14.144)$$

These equations assume continuous load current.

14.4.2iii - $\alpha > 5\pi/6$. A delay angle of greater than $5\pi/6$ would imply a negative output voltage, clearly not possible with a freewheel load diode.

Example 14.7: Three-phase half-wave rectifier with freewheel diode

The half-wave three-phase rectifier in figure 14.12 has a three-phase 415V 50Hz source (240V phase), and a 10 Ω resistor and infinite series inductance as a load. If the delay angle is 60° determine the load current and output voltage if:

- i. the phase commutation inductance is zero
- ii. the phase commutation reactance is $\frac{1}{4}\Omega$

Solution

i. The output voltage, without any line commutation inductance and a 60° phase delay angle, is given by equation (14.142)

$$V_o = \bar{I}_o R = \frac{\sqrt{2}V}{2\pi/3} (1 + \cos(\alpha + \pi/6))$$

$$= \frac{\sqrt{2} \, 240\text{V}}{2\pi/3} (1 + \cos(60^\circ + \pi/6)) = 162\text{V}$$

The constant load current is therefore

$$I_o = \frac{V_o}{R} = \frac{162\text{V}}{10\Omega} = 16.2\text{A}$$

ii. When the current changes paths, any inductance will control the rate at which the commutation from one path to the next occurs. The voltage drops across the commutating inductors modifies the output voltage. Since the voltage across the freewheel diode is not associated with commutation inductance, the output voltage is not effected when the current swaps from a phase to the freewheel

diode. But when the current transfers from the freewheel diode to a phase, while the commutation inductance current in the phase is building up to the constant load current level, the output remains clamped at the diode voltage level, viz. zero. The average voltage across the load during this overlap period is therefore reduced. The commutation current is defined by

$$\sqrt{2}V \sin \omega t = L_c \frac{di_c}{dt} = X_c \frac{di_c}{d\omega t}$$

$$i_c = \frac{\sqrt{2}V}{X_c} \left(\cos \left(\alpha + \frac{\pi}{6} \right) - \cos \omega t \right)$$

Solving for when the current rises to the load current I_o^γ gives

$$I_o^\gamma = \frac{\sqrt{2}V}{X_c} \left(\cos \left(\alpha + \frac{\pi}{6} \right) - \cos \left(\alpha + \frac{\pi}{6} + \gamma \right) \right)$$

but

$$I_o^\gamma = \frac{V_o^\gamma}{R} = \frac{\sqrt{2}V}{R 2\pi/3} (1 + \cos(\alpha + \pi/6 + \gamma))$$

$$\frac{\cos \left(\alpha + \frac{\pi}{6} \right) - \frac{X_c}{R 2\pi/3}}{\frac{X_c}{R 2\pi/3} + 1} = \cos \left(\alpha + \frac{\pi}{6} + \gamma \right)$$

$$\gamma = \cos^{-1} \left(\frac{\cos \left(\alpha + \frac{\pi}{6} \right) - \frac{X_c}{R 2\pi/3}}{\frac{X_c}{R 2\pi/3} + 1} \right) - \left(\alpha + \frac{\pi}{6} \right) = 0.68^\circ$$

The load current and voltage are therefore

$$I_o^\gamma = \frac{\sqrt{2}V}{X_c} \left(\cos \left(\alpha + \frac{\pi}{6} \right) - \cos \left(\alpha + \frac{\pi}{6} + \gamma \right) \right) = \frac{\sqrt{2} 240V}{\frac{1}{4}\Omega} (\cos 90^\circ - \cos 90.68^\circ) = 16.11A$$

$$V_o^\gamma = I_o^\gamma R = 16.11A \times 10\Omega = 161.1V$$

♣

14.4.3 Three-phase, full-wave, fully-controlled circuit with an inductive load

A three-phase bridge is fully controlled when all six bridge devices are thyristors, as shown in figure 14.13a. The frequency of the output ripple voltage is six times the supply frequency and each thyristor always conducts for $\frac{2}{3}\pi$. Circuit waveforms are shown in figure 14.13b. The output voltage is **continuous**, and the mean output voltage for both inductive and resistive loads is given by

$$\begin{aligned} V_o &= \frac{3}{\pi} \int_{\alpha+\pi/6}^{\alpha+1/2\pi} \sqrt{3}\sqrt{2}V \sin(\omega t + \frac{1}{6}\pi) d\omega t \\ &= \frac{3\sqrt{3}}{\pi} \sqrt{2}V \cos \alpha = 2.34V \cos \alpha \end{aligned} \quad (V) \quad (14.145)$$

$$0 \leq \alpha \leq 2\pi/3$$

which is twice the voltage given by equation (14.134) for the half-wave circuit, but for a purely resistive load the output voltage is **discontinuous** and equation (14.145) becomes

$$V_o = \frac{3}{\pi} V_{\max} [1 + \cos(\alpha + \frac{1}{6}\pi)] = \frac{3\sqrt{3}}{\pi} \sqrt{2}V [1 + \cos(\alpha + \frac{1}{6}\pi)] \quad (V) \quad (14.146)$$

$$\pi/3 \leq \alpha \leq 2\pi/3$$

The average output current is given by $\bar{I}_o = V_o / R$ in each case. If a load back emf exists, the average current becomes

$$\bar{I}_o = \frac{V_o - E}{R} \quad (14.147)$$

The maximum mean output voltage $\hat{V}_o = \sqrt{2}V 3\sqrt{3}/\pi$ occurs at $\alpha = 0$. The normalised mean output V_n is

$$V_n = V_o / \hat{V}_o = \cos \alpha \quad (14.148)$$

For delay angles up to $\frac{1}{3}\pi$, the output voltage is at all instances non-zero, hence the load current is continuous for any passive load (both resistive and inductive). Beyond $\frac{1}{3}\pi$ the load current may be discontinuous (always discontinuous for a resistive load). For $\alpha > \frac{1}{2}\pi$ the current is always discontinuous for passive loads (no back emf, E) and the average output voltage is less than zero

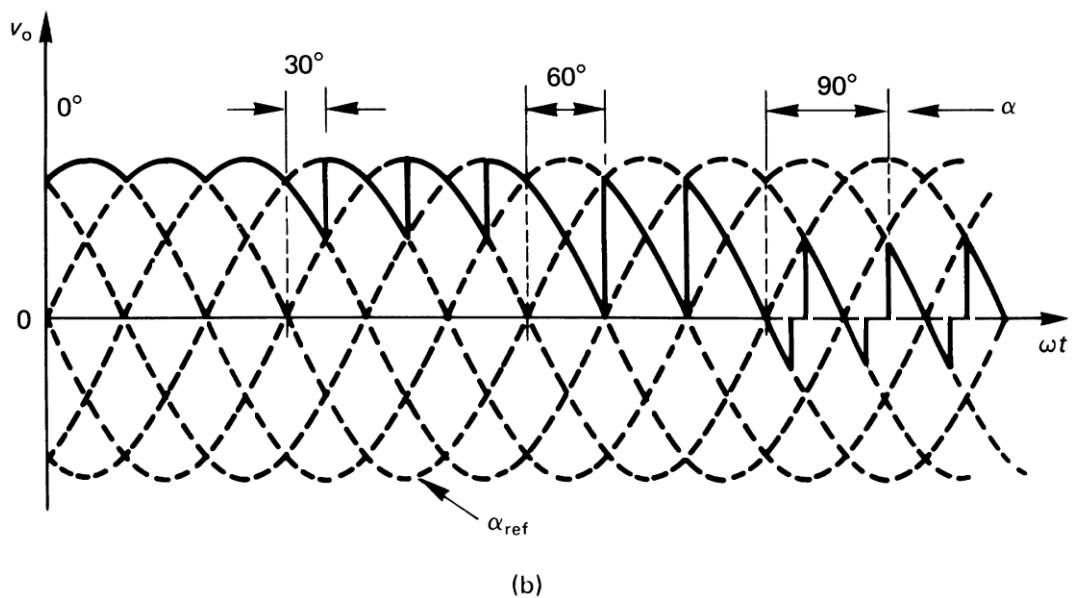
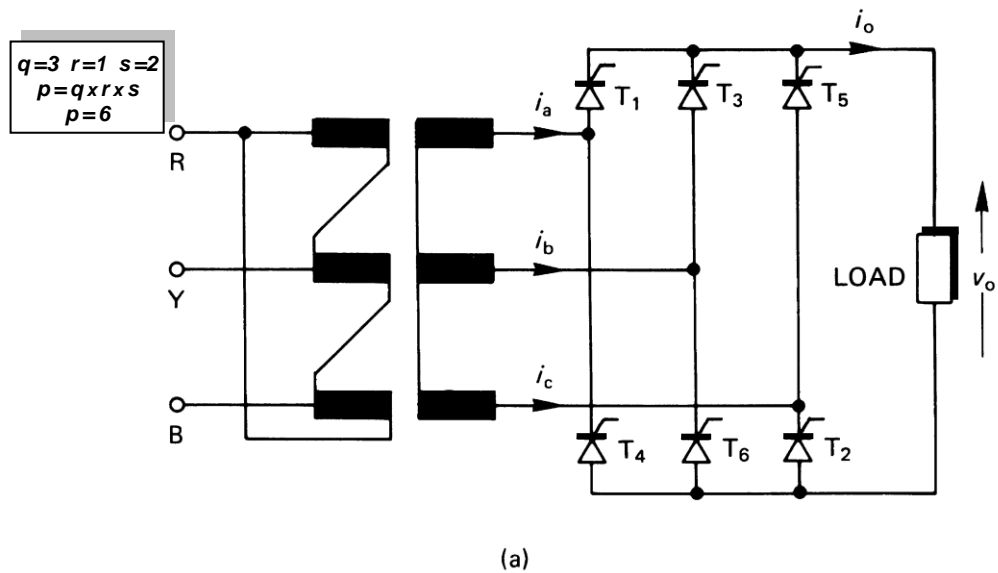

Figure 14.13. A three-phase fully controlled converter: (a) circuit connection and (b) load voltage waveform for four delay angles.

For **continuous load current**, the load current is given by

$$i(\omega t) = \frac{\sqrt{3}\sqrt{2}V}{Z} \sin\left(\omega t + \frac{\pi}{6} - \phi\right) - \frac{E}{R} + \frac{\sqrt{3}\sqrt{2}V}{Z} \sin(\alpha - \phi) \frac{e^{-\omega t + \pi/6 + \alpha/\tan\phi}}{e^{-\pi/3\tan\phi} - 1} \quad (14.149)$$

The maximum and minimum ripple current magnitudes are

$$\hat{I} = \frac{\sqrt{3}\sqrt{2}V}{Z} \sin\left(\alpha + \frac{\pi}{2} - \phi\right) - \frac{E}{R} + \frac{\sqrt{3}\sqrt{2}V}{Z} \sin(\alpha - \phi) \frac{e^{\pi/6/\tan\phi}}{e^{-\pi/3/\tan\phi} - 1} \quad (14.150)$$

at $\omega t = \alpha + \frac{1}{6}n\pi$ for $n = 0, 6, 12, \dots$

$$\check{I} = \frac{\sqrt{3}\sqrt{2}V}{Z} \sin\left(\alpha + \frac{\pi}{3} - \phi\right) - \frac{E}{R} + \frac{\sqrt{3}\sqrt{2}V}{Z} \sin(\alpha - \phi) \frac{1}{e^{-\pi/3/\tan\phi} - 1} \quad (14.151)$$

at $\omega t = \alpha - \frac{1}{6}\pi + \frac{1}{6}n\pi$ for $n = 0, 6, 12, \dots$

With a load back emf the critical inductance for continuous load current must satisfy $\dot{I} = 0$ in equation (14.151), that is

$$\frac{R}{Z} \times \left[\sin(\alpha - \phi + \frac{1}{3}\pi) + \frac{\sin(\alpha - \phi)}{e^{-\pi/3 \tan \phi} - 1} \right] \geq \frac{E}{\sqrt{3}\sqrt{2}V} \tag{14.152}$$

where $\tan \phi = \omega L / R$.

The rms value of the output voltage for an inductive and purely resistive load (**continuous**) is given by

$$V_{rms} = \left(\frac{3}{\pi} \int_{\alpha-\pi/6}^{\alpha+\pi/2} 3(\sqrt{2}V)^2 \sin^2(\omega t) d\omega t \right)^{1/2} \quad 0 \leq \alpha \leq \pi/3 \tag{14.153}$$

$$= \sqrt{3}\sqrt{2}V \sqrt{\frac{1}{2} + \frac{3\sqrt{3}}{4\pi} \cos 2\alpha}$$

but for a purely resistive load (**discontinuous**)

$$V_{rms} = \sqrt{3}\sqrt{2}V \sqrt{1 - \frac{3\alpha}{2\pi} - \frac{3}{4\pi} \sin(2\alpha - \pi/3)} \quad \pi/3 \leq \alpha \leq 2\pi/3 \tag{14.154}$$

The output voltage ripple factor (with continuous current) is

$$RF_v(\alpha) = \sqrt{\frac{\pi^2}{18} + \frac{\sqrt{3}\pi}{12} \cos 2\alpha - \cos^2 \alpha} \quad (\min(\text{at } \alpha=0) = 0.025; \max(\text{at } \alpha=\frac{1}{2}\pi) = 0.3) \tag{14.155}$$

and the efficiency is

$$\eta(\alpha) = 1 / FF^2 = 1 / \left(1 + \frac{3\sqrt{3}}{2\pi} \cos 2\alpha \right)^2$$

The normalise voltage harmonic peak magnitudes in the output voltage, with continuous load current, are

$$V_{Ln} = \sqrt{2}V \frac{3\sqrt{3}}{\pi} \left(\frac{1}{(n-1)^2} + \frac{1}{(n+1)^2} - \frac{2 \cos 2\alpha}{(n-1)(n+1)} \right)^{1/2} \tag{14.156}$$

for $n = 6, 12, 18, \dots$

The harmonics occur at multiples of six times the fundamental frequency.

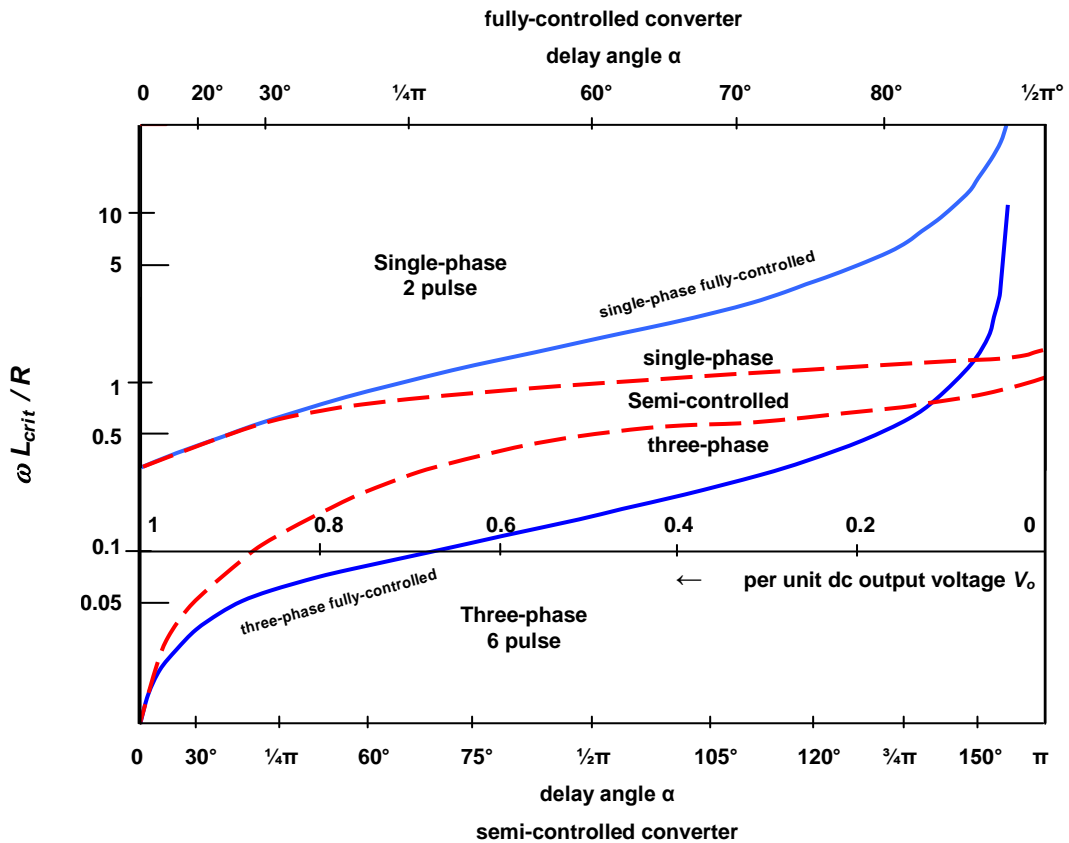

Figure 14.14. Critical load inductance (reactance) of single-phase (two pulse) and three-phase (six pulse), semi-controlled and fully-controlled converters, as a function phase delay angle α whence dc output voltage V_o . For a rectifier, $\alpha = 0$.

For **discontinuous load current**, at high delay angles, when the output current becomes discontinuous with an inductive load, the output current is given by

$$i(\omega t) = \frac{\sqrt{3}\sqrt{2}V}{Z} \left[\sin\left(\omega t + \frac{\pi}{6} - \phi\right) - \sin\left(\alpha + \frac{\pi}{3} - \phi\right) e^{-\omega t - \pi/6 + \alpha/\tan\phi} \right] - \frac{E}{R} \left[1 - e^{-\omega t - \pi/6 + \alpha/\tan\phi} \right] \quad (14.157)$$

$$\alpha \leq \omega t \leq \alpha + \theta_c$$

where θ_c is the conduction period, which is found by solving the transcendental equation formed when in equation (14.157), $i(\omega t = \alpha + \frac{1}{6}\pi + \theta_c) = 0$. The average output voltage can then be found from

$$V_o = \frac{3\sqrt{3}\sqrt{2}V}{\pi} \left[\cos\left(\alpha + \frac{\pi}{3}\right) - \cos\left(\alpha + \frac{\pi}{3} + \theta_c\right) \right] - \frac{3E}{\pi} \left[\frac{\pi}{3} - \theta_c \right] \quad (14.158)$$

14.4.3i - Resistive load

For a resistive load, the load voltage harmonics for p pulses per cycle, are given by

$$a_n = \frac{\sqrt{2}V}{2\pi/p} \left[\frac{-2}{n^2 + 1} - \frac{\cos(n+1)\alpha}{n+1} - \frac{\cos(n-1)\alpha}{n-1} \right]$$

$$b_n = \frac{\sqrt{2}V}{2\pi/p} \left[\frac{\sin(n+1)\alpha}{n+1} - \frac{\sin(n-1)\alpha}{n-1} \right] \quad (14.159)$$

for $n = pm$ and $m = 1, 2, 3, \dots$. The harmonics occur at multiples of six times the fundamental frequency, for a 6-pulse ($p=6$) per cycle output voltage.

14.4.3ii - Highly inductive load – constant load current

As with a continuous load current, with a constant load current the input current comprises $\frac{2}{3}\pi$ alternating polarity blocks of current, with each phase displaced relative to the others by $\frac{2}{3}\pi$, independent of the thyristor triggering delay angle. At maximum voltage hence maximum power output, the delay angle is zero and the phase voltage and current fundamental are in phase. As the phase angle is increased, the inverter output voltage, hence power output is decreased, and the line current block of current (fundamental) shifts by α with respect to the line voltage. Reactive input power increases as the real power decreases. At $\alpha = \frac{1}{2}\pi$, the output voltage reduces to zero, the output power is zero, and the $\frac{2}{3}\pi$ current blocks in the ac input are shifted $\frac{1}{2}\pi$ with respect to the line voltage, producing only VAR's from the ac input. When the delay angle is increased above $\frac{1}{2}\pi$, the inverter dc output reverses polarity and energy transfers back into the ac supply (inversion), with maximum inverted power reached at $\alpha = \pi$, where the reactive VAR is reduced to zero, from a maximum at $\alpha = \frac{1}{2}\pi$.

For a highly inductive load, that is a constant load current \bar{I}_o :

the mean diode current is

$$\bar{I}_{Th} = \frac{1}{n} \bar{I}_o = \frac{1}{3} \bar{I}_o \quad (A) \quad (14.160)$$

and the rms diode current is

$$I_{Th\ rms} = \frac{1}{\sqrt{n}} I_{o\ rms} \approx \frac{1}{\sqrt{n}} \bar{I}_o = \frac{1}{\sqrt{3}} \bar{I}_o \quad (A) \quad (14.161)$$

The diode current form factor is

$$FF_{Th} = I_{Th\ rms} / \bar{I}_{Th} = \sqrt{3} \quad (14.162)$$

The diode current ripple factor is

$$RF_{Th} = \sqrt{FF_{Th}^2 - 1} = \sqrt{2} \quad (14.163)$$

The rms input line currents are

$$I_{L\ rms} = \sqrt{\frac{2}{3}} I_{o\ rms} = 0.816 I_{o\ rms} \quad (14.164)$$

A phase voltage is given by

$$v_a = \sqrt{2} V \sin \omega t \quad (14.165)$$

with phases b and c shifted by $\frac{2}{3}\pi$. That is substitute ωt with $\omega t \pm \frac{2}{3}\pi$.

The line current i_a is given by

$$i_a(\omega t - \phi_1) = \frac{2\sqrt{3}}{\pi} I_o \left(\sin \omega t - \frac{1}{5} \sin 5\omega t - \frac{1}{7} \sin 7\omega t + \frac{1}{11} \sin 11\omega t + \frac{1}{13} \sin 13\omega t \right. \\ \left. - \frac{1}{17} \sin 17\omega t - \frac{1}{19} \sin 19\omega t + \dots \right) \quad (14.166)$$

where Φ_1 is the angle between the supply v_a and the fundamental line current i_{a1} .

From Fourier coefficients of the line current harmonics are

$$\begin{aligned}
 a_n &= \frac{1}{\pi} \int_0^{2\pi} i_i(t) \cos n\omega t \, d\omega t \\
 &= \frac{1}{\pi} \left[\int_{\frac{\pi}{6}+\alpha}^{\frac{5\pi}{6}+\alpha} \bar{I}_o \cos n\omega t \, d\omega t - \int_{\frac{7\pi}{6}+\alpha}^{\frac{11\pi}{6}+\alpha} \bar{I}_o \cos n\omega t \, d\omega t \right] \\
 &= -\frac{4\bar{I}_o}{n\pi} \sin \frac{n\pi}{3} \sin n\alpha \quad n = 1, 3, 5, \dots \text{odd}
 \end{aligned} \tag{14.167}$$

$$\begin{aligned}
 b_n &= \frac{1}{\pi} \int_0^{2\pi} i_s(t) \sin n\omega t \, d\omega t \\
 &= \frac{1}{\pi} \left[\int_{\frac{\pi}{6}+\alpha}^{\frac{5\pi}{6}+\alpha} \bar{I}_o \sin n\omega t \, d\omega t - \int_{\frac{7\pi}{6}+\alpha}^{\frac{11\pi}{6}+\alpha} \bar{I}_o \sin n\omega t \, d\omega t \right] \\
 &= \frac{4\bar{I}_o}{n\pi} \sin \frac{n\pi}{3} \cos n\alpha \quad n = 1, 3, 5, \dots \text{odd}
 \end{aligned} \tag{14.168}$$

$$\text{such that } \sqrt{a_n^2 + b_n^2} = \frac{4\bar{I}_o}{n\pi} \sin \frac{n\pi}{3}$$

The input line current, which has no dc component ($a_n=0$), is

$$i_i(t) = \sum_{n=1,3,5,\dots}^{\infty} \frac{4\bar{I}_o}{n\pi} \sin \frac{n\pi}{3} \sin(n\omega t - n\alpha) \tag{14.169}$$

The fundamental input current and rms are

$$I_{i1}(t) = \frac{2\sqrt{3}\bar{I}_o}{\pi} \sin(\omega t - \alpha) = \sqrt{2} I_{1rms} \sin(\omega t - \alpha) \tag{14.170}$$

$$\text{where } I_{1rms} = \sqrt{3} \frac{\sqrt{2}}{\pi} \bar{I}_o$$

The power factor for a constant load current is

$$pf = \frac{\sqrt{3}V_{rms} I_{1rms} \cos \alpha}{\sqrt{3}V_{rms} \times \sqrt{\frac{2}{3}} \bar{I}_o} = \frac{\sqrt{3}V_{rms} \sqrt{3} \frac{\sqrt{2}}{\pi} \bar{I}_o \cos \alpha}{\sqrt{3}V_{rms} \times \sqrt{\frac{2}{3}} \bar{I}_o} = \frac{3}{\pi} \cos \alpha = 0.995 \cos \alpha \quad (= DF \times DPF) \tag{14.171}$$

where $\cos \alpha$ is the displacement factor, DPF, the cosine of the angle between the fundamental input voltage and current, Φ_1 , as given in equation (14.170). The displacement factor is the component $3/\pi$.

The supply fundamental apparent power, S_1 , active power P and reactive power Q , are given by

$$\begin{aligned}
 S_1 &= \sqrt{3} V I_{1rms} = 3V \frac{\sqrt{2}}{\pi} \bar{I}_o = \frac{3\sqrt{2}V}{\pi} \bar{I}_o = \sqrt{P_d^2 + Q_d^2} \\
 P_d &= P_1 = S_{\max} \cos \alpha
 \end{aligned} \tag{14.172}$$

$$Q_d = Q_1 = S_{\max} \sin \alpha \quad \text{where } P_{\max} = \left| \frac{3\sqrt{2}V}{\pi} \bar{I}_o \right| = |Q_{\max}| = |S_{\max}|$$

The apparent power drawn by the 6-pulse converter, for a constant load current is

$$\begin{aligned}
 S_d &= P_d + j Q_d \\
 &= S_{\max} (\cos \alpha + j \sin \alpha)
 \end{aligned} \tag{14.173}$$

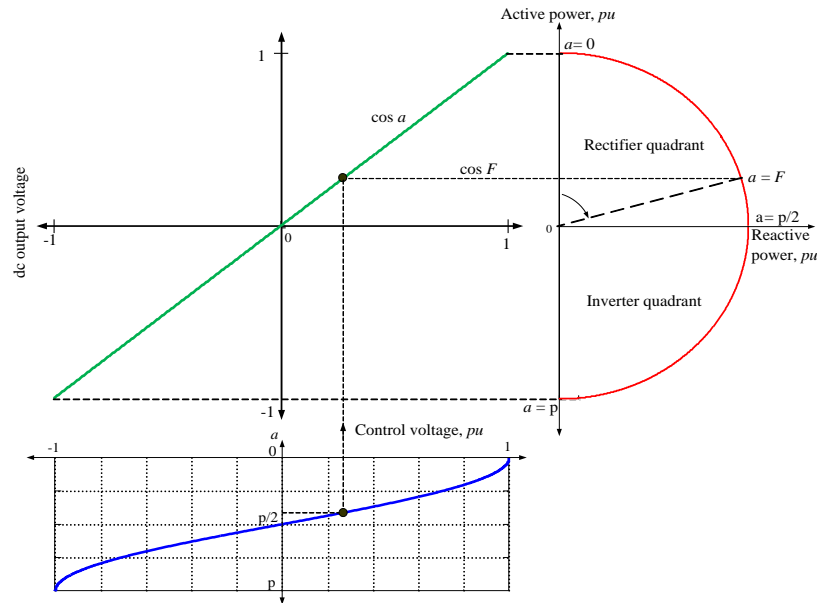

Figure 14.15. Power locus of 6-pulse converter and per unit output voltage.

The supply apparent power is constant for a given constant load current, independent of the thyristor turn-on delay angle. Maximum power is drawn for zero delay angle, while maximum apparent power is drawn at $\alpha = \frac{1}{2}\pi$. Dividing equation (14.173) by S_1 gives the system power locus in per unit. The semicircle shown in figure 14.15 with centre 'o' and a radius of 1 pu is the P - Q locus of the 6-pulse converter obtained by varying α from 0 to π in equation (14.173). The pu output voltage is $\cos\alpha$.

The supply power factor, equation (14.171), is defined as the ratio of the supply power delivered P , to apparent supply power S ,

$$pf = \frac{P}{S} = \frac{I_{s1}}{I_s} \cos\alpha = \frac{3}{\pi} \times \cos\alpha = DF \times DPF = \frac{DPF}{\sqrt{1 + THD^2}} \quad (14.174)$$

where $DPF = \cos\alpha = \cos\Phi_1$, $DF = I_{s1}/I_s = 3/\pi$, and the total harmonic input current distortion, THD , from equations (14.164) and (14.170) is

$$THD = \frac{\sqrt{I_s^2 - I_{s1}^2}}{I_{s1}} = \sqrt{\frac{I_s^2}{I_{s1}^2} - 1} = \sqrt{\left(\frac{\pi}{3}\right)^2 - 1} = 0.311 \quad (14.175)$$

The dc-side voltage harmonics of the 6-pulse converter are generated at $6n$ times the fundamental line frequency. The output voltage, V_o , can be expressed as a Fourier series (see equation (14.156)):

$$V_o = \frac{3\sqrt{2}V_L}{\pi} \left(\cos\alpha + \sum_{n=1}^{\infty} \sqrt{\frac{1}{(6n-1)^2} + \frac{1}{(6n+1)^2} + \frac{2\cos 2\alpha}{(6n-1)(6n+1)}} \sin(6n\omega t + \lambda_{6n}) \right) \quad (14.176)$$

where

$$\lambda_{6n} = -n\pi + \tan^{-1} \left[\frac{\frac{\cos(6n+1)\alpha}{6n+1} - \frac{\cos(6n-1)\alpha}{6n-1}}{\frac{\sin(6n+1)\alpha}{6n+1} - \frac{\sin(6n-1)\alpha}{6n-1}} \right]$$

For a highly inductive load, the harmonic components tend to zero whence the average output voltage from equation (14.176) reduces to equation (14.145), whilst the rms output voltage is given by (14.153). The output current in the time domain, from equation (14.149), is

$$i_o(\omega t) = \frac{\sqrt{3}\sqrt{2}V}{Z} \left[\sin(\omega t + \frac{1}{3}\pi - \phi) + \frac{\sin(\phi - \alpha)}{1 - e^{-\frac{\pi}{3\tan\phi}}} e^{-\frac{\omega t - \alpha}{\tan\phi}} \right] \quad (14.177)$$

Undesirably, if triggering pulses to all the thyristors are removed, the dc current decays slowly and uncontrolled to zero through the last pair of thyristors that were triggered. Converter shut down is best achieved regeneratively by increasing (and controlling) the delay angle to greater than $\frac{1}{2}\pi$ such that the output voltage goes negative, which results in controlled power inversion back into the ac supply. Series and parallel connection of fully-controlled, phase-shifted converters is considered in Chapter 23, in relation to HVDC transmission.

14.4.3iii - R-L load with load EMF, E

The load current during the interval $\alpha \leq \omega t \leq \alpha + \frac{1}{3}\pi$ is defined by

$$Ri + L \frac{di}{dt} + E = \sqrt{2}V_L \sin(\omega t + \frac{1}{3}\pi) \quad (14.178)$$

which, provided it is continuous, yields

$$i(t) = \frac{\sqrt{2}V_L}{Z} \left[\frac{\sin(\phi - \alpha)}{1 - e^{\frac{-\pi}{3\tan\phi}}} e^{\frac{-\omega t + \alpha}{\tan\phi}} + \sin(\omega t + \frac{1}{3}\pi - \phi) - \frac{\sin \check{\alpha}}{\cos \phi} \right] \quad (14.179)$$

where $Z = \sqrt{R^2 + \omega^2 L^2}$; $\tan \phi = \omega L / R$; $R = Z \cos \phi$; and $E = \sqrt{2}V_L \sin \check{\alpha}$.

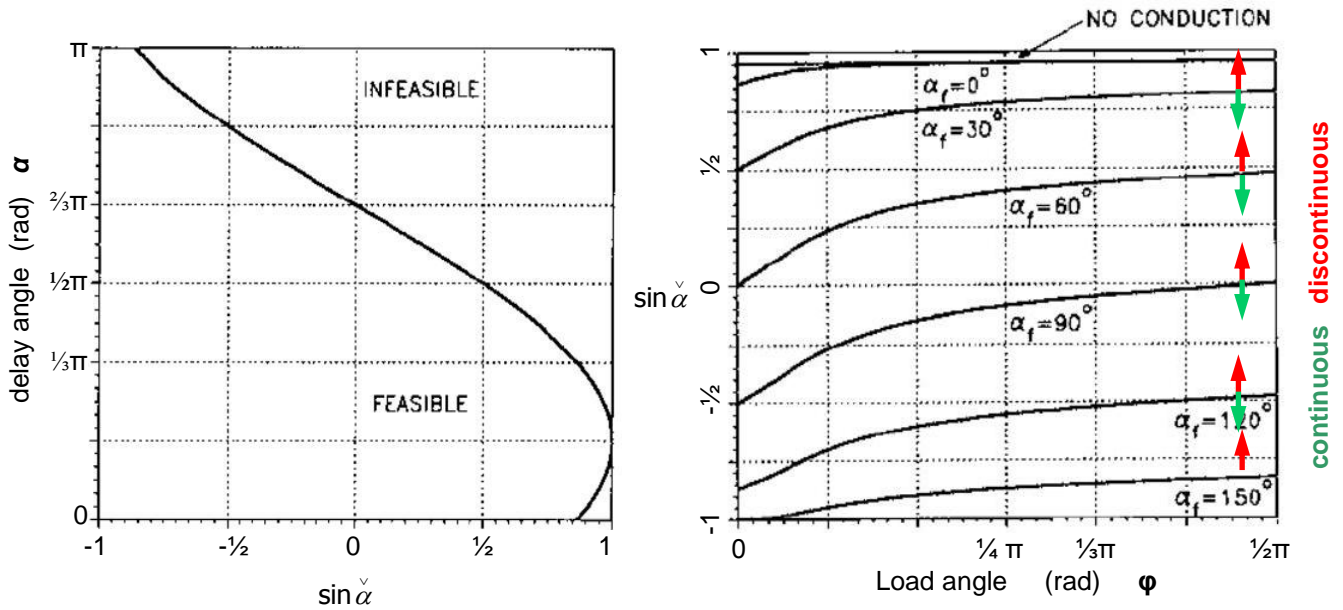

Figure 14.16. Conduction constraints with load back emf:
(a) minimum delay angle and (b) load dependence.

The boundary for continuous load current, figure 14.16, $i(\omega t = \alpha) > 0$, from equation (14.179), is

$$\sin \check{\alpha} > \left[\frac{\sin(\phi - \alpha)}{1 - e^{\frac{-\pi}{3\tan\phi}}} \times 1 + \sin(\alpha + \frac{1}{3}\pi - \phi) \right] \cos \phi$$

In the discontinuous mode current conduction starts at $\omega t = \alpha_c$ and can be obtained from (14.157) as

$$i_{dis}(t) = \frac{\sqrt{2}V_L}{Z} \left[\left(\frac{\sin \check{\alpha}}{\cos \phi} - \sin(\frac{1}{3}\pi + \alpha - \phi) \right) e^{\frac{-\omega t + \alpha_f}{\tan\phi}} + \sin(\omega t + \frac{1}{3}\pi - \phi) - \frac{\sin \check{\alpha}}{\cos \phi} \right]$$

while the average output voltage is obtained from equation (14.158):

$$V_{o,dis} = \frac{3}{\pi} \sqrt{2}V \left[2 \sin \frac{1}{2}\beta \sin(\frac{1}{3}\pi + \alpha + \frac{1}{2}\beta) + (\frac{1}{3}\pi - \beta) \sin \check{\alpha} \right]$$

where the conduction angle $\beta = \alpha_c - \alpha$. In continuous conduction, $\beta = \frac{1}{3}\pi$, which gives equation (14.148). The supply power factor is $\frac{3}{\pi} \cos \alpha$.

Example 14.8: Three-phase full-wave controlled rectifier with constant output current

The full-wave three-phase controlled rectifier in figure 14.13a has a three-phase 415V 50Hz source (240V phase), and provides a 100A constant current load.

Determine:

- i. the average and rms thyristor current
- ii. the rms and fundamental line current
- iii. the apparent fundamental power S_1

If 25kW is delivered to the dc load, calculate:

- iv. the supply power factor
- iv. the dc output voltage, load resistance, hence the converter phase delay angle
- v. the real active and reactive Q_1 ac supply power
- vi. the delay angle range if the ac supply varies by $\pm 5\%$ (with 25kW and 100A dc).

Solution

- i. From equations (14.160) and (14.161) the thyristor average and rms currents are

$$\bar{I}_{Th} = \frac{1}{3} \bar{I}_o = \frac{1}{3} \times 100A = 33 \frac{1}{3} A$$

$$I_{Th\,rms} = \sqrt{\frac{1}{3}} \bar{I}_o = \sqrt{\frac{1}{3}} \times 100A = 57.7A$$

- ii. The rms and fundamental line currents are

$$I_{L\,rms} = \sqrt{\frac{2}{3}} I_{o\,rms} = \sqrt{\frac{2}{3}} \times 100A = 81.6A$$

$$I_{1\,rms} = \sqrt{3} \frac{\sqrt{2}}{\pi} \bar{I}_o = \sqrt{3} \frac{\sqrt{2}}{\pi} \times 100A = 78.0A$$

- iii. The apparent power is

$$S_1 = \sqrt{3} V I_{1\,rms} = \sqrt{3} \times 415V \times 78A = 56.1kVA$$

- iv. The supply power factor, from equation (14.171), is

$$pf = \frac{P_L}{\sqrt{3} V_{rms} I_{rms}} = \frac{25kW}{\sqrt{3} \times 415V \times 81.6A} = 0.426 \quad \left(= \frac{3}{\pi} \cos \alpha \right)$$

- v. The output voltage is

$$V_o = \frac{\text{power}}{I_o} = \frac{25kW}{100A} = 250V \text{ dc}$$

The load resistance is

$$R_L = \frac{V_o}{I_o} = \frac{250V}{100A} = 2.5\Omega$$

Thyristor delay angle is given by equation (14.145), that is

$$V_o = 2.34V \cos \alpha$$

$$250Vdc = 2.34 \times \frac{415V}{\sqrt{3}} \times \cos \alpha$$

which yields a delay angle of $\alpha = 1.11\text{rad} = 63.5^\circ$

- vi. For a constant output power at 100A dc, the output voltage must be maintained at 250V dc independent of the ac input voltage magnitude, thus for equation (14.145)

$$\alpha = \cos^{-1} \frac{250Vdc}{2.34 \times \frac{(415 \pm 5\%)V}{\sqrt{3}}}$$

$$\check{\alpha} = \cos^{-1} \frac{250Vdc}{2.34 \times \frac{(415 - 5\%)V}{\sqrt{3}}} = 1.08\text{rad} = 61.9^\circ$$

$$\hat{\alpha} = \cos^{-1} \frac{250Vdc}{2.34 \times \frac{(415 + 5\%)V}{\sqrt{3}}} = 1.13\text{rad} = 64.9^\circ$$

♣

14.4.4 Three-phase, full-wave converter with freewheel diode

Both half-controlled and fully controlled converters can employ a discrete load freewheel diode. These circuits have the voltage output characteristic that the output voltage can never go negative, hence power inversion is not possible. Figure 14.17 shows a fully controlled three-phase converter with a freewheel diode D. Thyristor/diode variations similar to those shown in figure 14.1 are possible.

- The freewheel diode is only active for $\alpha > \frac{1}{3}\pi$. The output is as in figure 14.13b for $\alpha < \frac{1}{3}\pi$. Each thyristor conducts for $\frac{2}{3}\pi$. The mean output voltage is

$$V_o = \bar{I}_o R = \frac{3\sqrt{3}}{\pi} \sqrt{2} V \cos \alpha = 2.34 V \cos \alpha \quad (\text{V}) \quad (14.180)$$

$$0 \leq \alpha \leq \pi / 3 \quad (\text{rad})$$

The maximum mean output voltage $\hat{V}_o = \sqrt{2} V 3\sqrt{3}/\pi$ occurs at $\alpha = 0$.

The normalised mean output voltage V_n is given by

$$V_n = V_o / \hat{V}_o = \cos \alpha \quad (14.181)$$

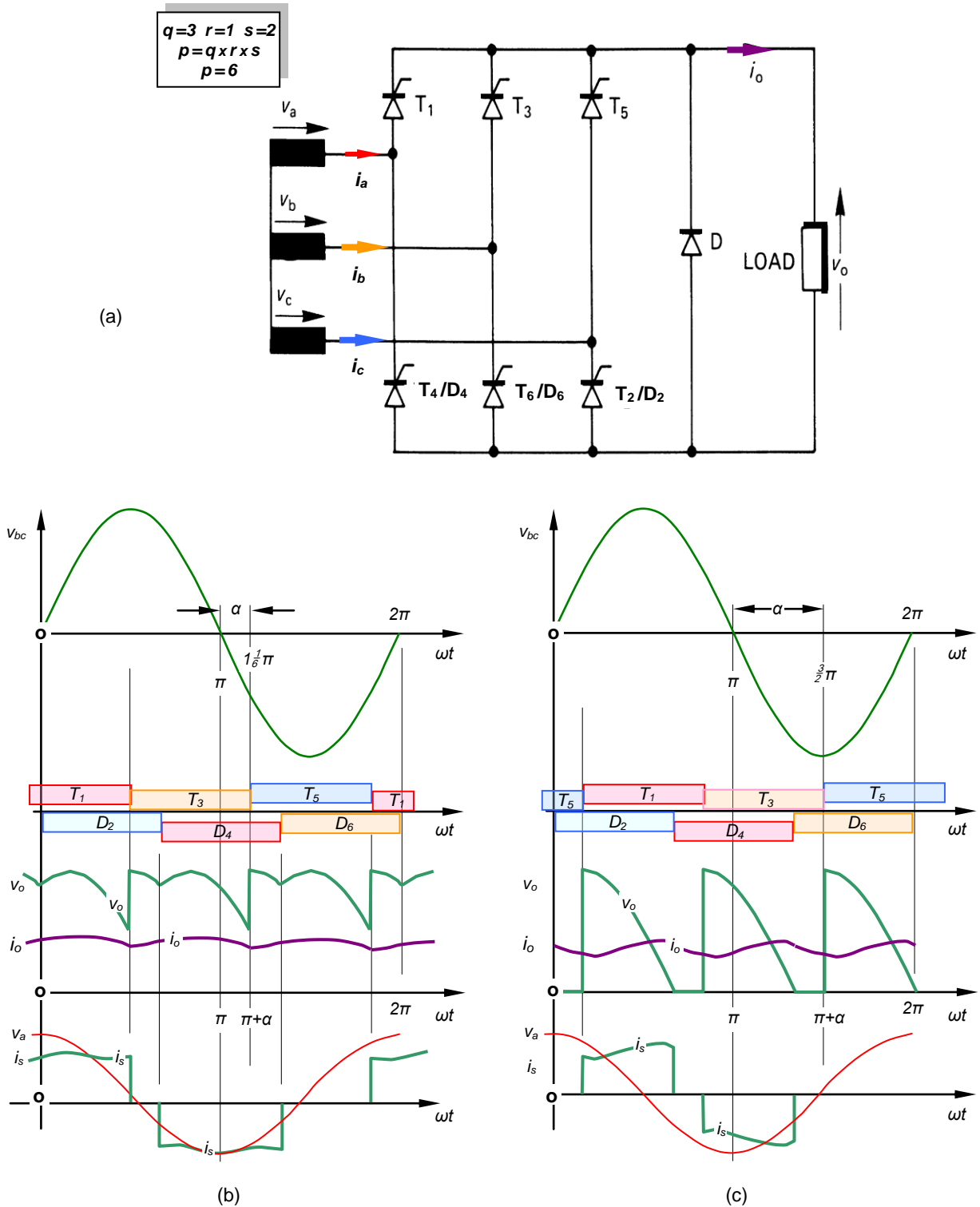

Figure 14.17. A full-wave three-phase half-controlled converter with a load freewheeling diode: (a) circuit; (b) $\alpha = \frac{1}{6}\pi$; and (c) $\alpha = \frac{1}{2}\pi$.

The rms output voltage is

$$V_{rms} = \sqrt{3}\sqrt{2}V\sqrt{\frac{3}{\pi}(\pi - \alpha + \frac{1}{2}\sin 2\alpha)} \quad (14.182)$$

- while

$$V_o = \bar{I}_o R = \frac{3\sqrt{3}}{\pi}\sqrt{2}V(1 + \cos(\alpha + \pi/3)) \quad (\text{V}) \quad (14.183)$$

$$\pi/3 \leq \alpha \leq 2\pi/3 \quad (\text{rad})$$

The normalised mean output, V_n , is

$$V_n = V_o / \hat{V}_o = 1 + \cos(\alpha + \pi/3) \quad (14.184)$$

The rms output voltage, assuming continuous conduction, is

$$V_{rms} = \sqrt{3}\sqrt{2}V\sqrt{\frac{3}{\pi}\left(\frac{2\pi}{3} + \sqrt{3}\cos^2 \alpha\right)} \quad (14.185)$$

- while

$$V_o = 0 \quad (\text{V}) \quad 2\pi/3 \leq \alpha \quad (\text{rad}) \quad (14.186)$$

In each case the average output current is given by $\bar{I}_o = V_o / R$, which can be modified to include any load back emf, that is, $\bar{I}_o = (V_o - E) / R$.

From the waveforms of figure 14.17, v_o is periodic over one third of the input cycle. Therefore, for $\alpha \leq \frac{1}{3}\pi$

$$v_o(\omega t) = V_o + \sum_{n=1}^{\infty} V_{An} \cos 3n\omega t + V_{Bn} \sin 3n\omega t$$

where

$$V_{An} = \frac{3\sqrt{2}}{2\pi}V_L \left[\frac{1 + (-1)^n \cos(3n+1)\alpha}{3n+1} + \frac{1 + (-1)^n \cos(3n-1)\alpha}{3n-1} \right]$$

$$V_{Bn} = \frac{3\sqrt{2}}{2\pi}V_L \sin \frac{1}{2}n\pi \left[\frac{\sin(3n+1)\alpha}{3n+1} + \frac{\sin(3n-1)\alpha}{3n-1} \right]$$

Similar results are obtained for $\alpha > \frac{1}{3}\pi$.

To find the Fourier series of the input ac line current, the load may be replaced by a constant current source \bar{I}_o having the same value as the average load current. This approximation will be valid provided the load current ripple is relatively small. With this assumption:

$$i_a(\omega t) = \sum_{n=1}^{\infty} [I_{an} \cos n\omega t + I_{bn} \sin n\omega t]$$

where

$$I_{an} = \frac{\bar{I}_o}{n\pi} [\cos n\alpha - (-1)^n] \sin \frac{1}{3}n\pi$$

$$I_{bn} = \frac{\bar{I}_o}{n\pi} \sin \frac{1}{3}n\pi \sin n\alpha$$

The fundamental component, with $n=1$, is

$$i_{a1} = \frac{2\sqrt{3}}{\pi} \bar{I}_o \cos \frac{1}{2}\alpha \cos(\omega t - \frac{1}{2}\alpha)$$

Assuming a constant load current results in

$$\text{displacement factor} = \cos \frac{1}{2}\alpha$$

$$\text{distortion factor} = \frac{I_{a1}}{I_1} = \frac{\frac{\sqrt{6}}{\pi} \bar{I}_o \cos \frac{1}{2}\alpha}{\bar{I}_o \sqrt{\frac{\pi - \alpha}{\pi}}} = \sqrt{\frac{6}{\pi(\pi - \alpha)}} \cos \frac{1}{2}\alpha$$

power factor = distortion factor x displacement factor

$$= \sqrt{\frac{6}{\pi(\pi - \alpha)}} \cos^2 \frac{1}{2}\alpha = \sqrt{\frac{3}{2\pi(\pi - \alpha)}} (1 + \cos \alpha)$$

With continuous load current, with an $R-L-E$ load, the closed form solution for the current is

For $0 \leq \alpha \leq \frac{1}{3}\pi$

$$i(t) = \frac{\sqrt{2}V}{Z} \left[\frac{e^{\frac{-\omega t + \alpha + \frac{1}{3}\pi}{\tan \phi}}}{1 - e^{\frac{-2\pi}{3 \tan \phi}}} \sin(\phi - \alpha) + \frac{e^{\frac{-\omega t}{\tan \phi}}}{1 - e^{\frac{-2\pi}{3 \tan \phi}}} \sin \phi + \sin(\omega t + \frac{1}{3}\pi - \phi) - \frac{\sin \alpha}{\cos \phi} \right] \quad (14.187)$$

For $\frac{1}{3}\pi \leq \alpha \leq \frac{2}{3}\pi$

$$i(t) = \frac{\sqrt{2}V}{Z} \left[\left\{ e^{\frac{-\omega t + \alpha + \frac{1}{3}\pi}{\tan \phi}} + \frac{e^{\frac{-\omega t + \alpha + \frac{1}{3}\pi}{\tan \phi}}}{1 - e^{\frac{-2\pi}{3 \tan \phi}}} \right\} \sin(\phi - \alpha) + \frac{e^{\frac{-\omega t}{\tan \phi}}}{1 - e^{\frac{-2\pi}{3 \tan \phi}}} \sin \phi + \sin(\omega t - \phi) - \frac{\sin \alpha}{\cos \phi} \right] \quad (14.188)$$

where $Z = \sqrt{R^2 + \omega^2 L^2}$; $\tan \phi = \omega L / R$; $R = Z \cos \phi$; and $E = \sqrt{2}V_L \sin \alpha$.

Example 14.9: Converter average load voltage

Derive a general expression for the average load voltage of a p -pulse controlled converter.

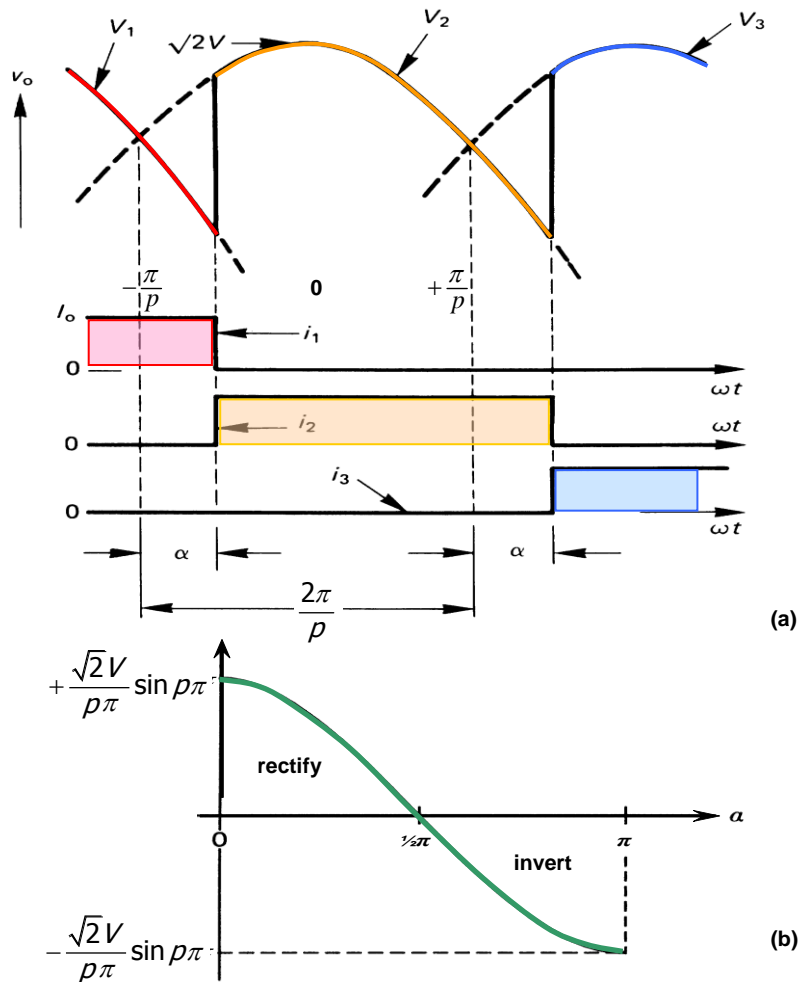

Figure 14.18. A half-wave n -phase controlled converter: (a) output voltage and current waveform and (b) transfer function of voltage versus delay angle α .

Solution

Figure 14.18 defines the general output voltage waveform where p is the output pulse number per cycle of the ac supply. From the output voltage waveform

$$\begin{aligned}
 V_o &= \frac{1}{2\pi/p} \int_{-\pi/n+\alpha}^{\pi/n+\alpha} \sqrt{2}V \cos \omega t \, d\omega t \\
 &= \frac{\sqrt{2}V}{2\pi/p} (\sin(\alpha + \pi/p) - \sin(\alpha - \pi/p)) \\
 &= \frac{\sqrt{2}V}{2\pi/p} 2\sin(\pi/p) \cos \alpha \\
 V_o &= \frac{\sqrt{2}V}{\pi/p} \sin(\pi/p) \cos \alpha \\
 &= \hat{V}_o \cos \alpha \quad (\text{V})
 \end{aligned}$$

where

for $p = 2$ for the single-phase ($n = 1$) full-wave controlled converter in figure 14.7.
 for $p = 3$ for the three-phase ($n = 3$) half-wave controlled converter in figure 14.11.
 for $p = 6$ for the three-phase ($n = 3$) full-wave controlled converter in figure 14.13.



14.5 Overlap

In the previous sections of this chapter, impedance of the ac source has been neglected, such that current transfers or *commutates* instantly from one switch to the other with higher anode potential, when triggered. However, in practice the source has inductive reactance X_c and current takes a finite time to fall in the device turning off and rise in the device turning on.

Consider the three-phase half-wave controlled rectifying converter in figure 14.11a, where it is assumed that a continuous dc load current, I_o , flows. When thyristor T_1 is conducting and T_2 (which is forward biased) is turned on after delay α , the equivalent circuit is shown in figure 14.19a. The source reactances X_1 and X_2 limit the rate of change of current in T_1 as i_1 decreases from I_o to 0 and in T_2 as i_2 increases from 0 to I_o . These current transitions in T_1 and T_2 are shown in the waveforms of figure 14.19d. A circulating current, i , flows between the two thyristors. If the line reactances are identical, for a constant output current, the inductor di/dt currents are equal and opposite, the output voltage during commutation, v_γ , is mid-way between the conducting phase voltages v_1 and v_2 , as shown in figure 14.19b. That is $v_\gamma = \frac{1}{2}(v_1 + v_2)$, creating a series of notches in the output voltage waveform as shown in figure 14.19c. This interval during which both T_1 and T_2 conduct ($i \neq 0$) is termed the *overlap period* and is defined by the *overlap angle* γ . Ignoring thyristor voltage drops, the overlap angle is calculated as follows:

$$v_2 - v_1 = 2L \frac{di}{dt}$$

With reference $t = 0$ when T_2 is triggered

$$v_2 - v_1 = v_L = \sqrt{3} v_{\text{phase}} = \sqrt{3}\sqrt{2} V \sin(\omega t + \alpha)$$

where V is the line to neutral rms voltage.

Equating these two equations

$$2L di / dt = \sqrt{3}\sqrt{2} V \sin(\omega t + \alpha)$$

Rearranging and integrating gives

$$i(\omega t) = \frac{\sqrt{3}\sqrt{2}V}{2\omega L} (\cos \alpha - \cos(\omega t + \alpha)) \quad (14.189)$$

Commutation from T_1 to T_2 is complete when $i = I_o$, at $\omega t = \gamma$, that is

$$I_o = \frac{\sqrt{3}\sqrt{2}V}{2\omega L} (\cos \alpha - \cos(\gamma + \alpha)) = \frac{2\pi V_o}{3\omega L} (\cos \alpha - \cos(\gamma + \alpha)) \quad (\text{A}) \quad (14.190)$$

This equation holds for $\gamma \leq \frac{1}{3}\pi$, provided

$$I_o \leq \frac{\sqrt{3}V}{\sqrt{2}\omega L} \cos(\alpha - \frac{1}{3}\pi) \quad \left[I_o \leq \frac{2\pi V_o}{3\omega L} \cos(\alpha - \frac{1}{3}\pi) \right]$$

Figure 14.19b shows that the load voltage comprises the phase voltage v_2 when no source inductance exists minus the voltage due to circulating current $v_\gamma (= \frac{1}{2}(v_1 + v_2))$ during commutation.

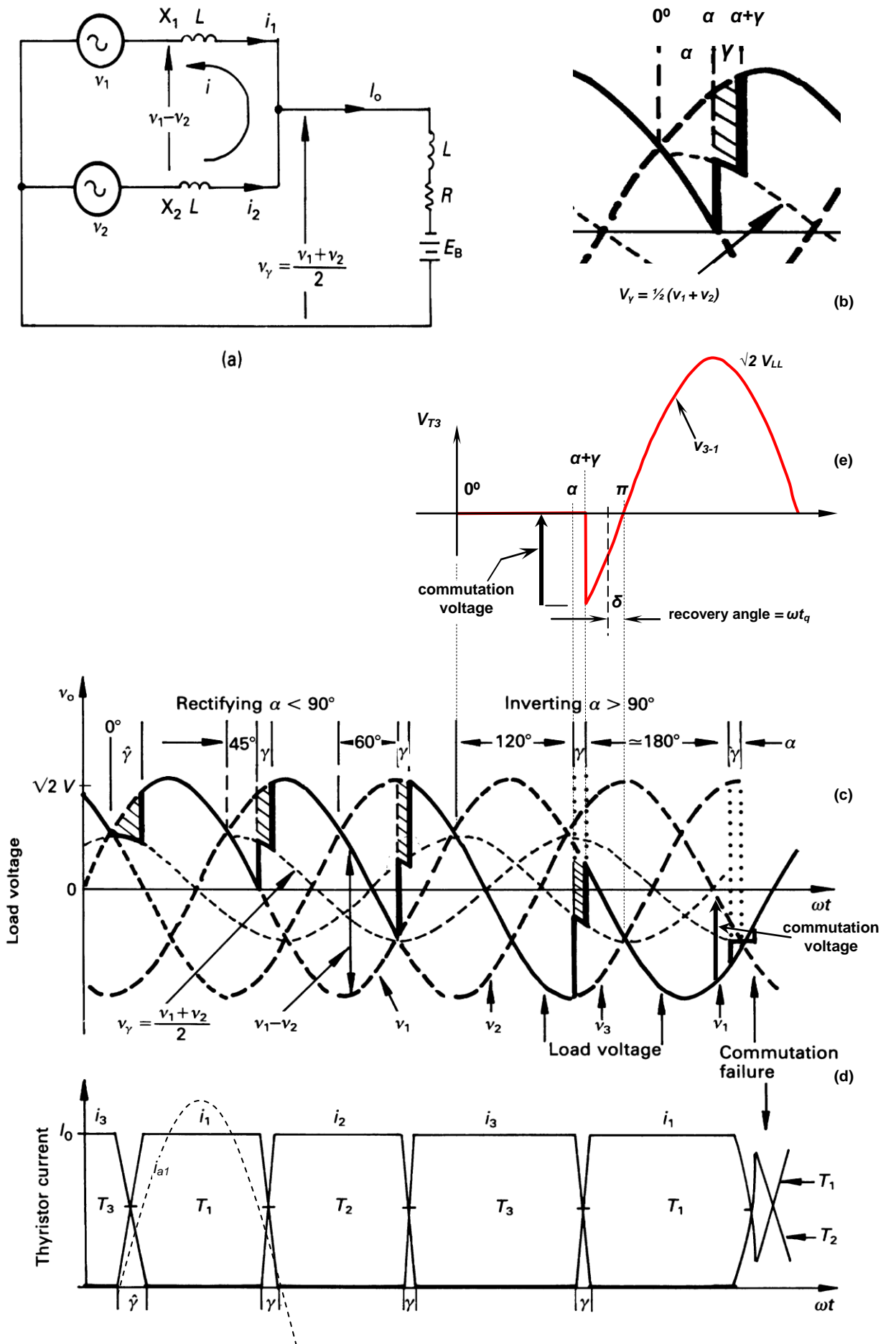

Figure 14.19. Overlap: (a) equivalent circuit during overlap; (b) angle relationships; (c) load voltage for different delay angles α (hatched areas equal to $I_o L$; last overlap shows commutation failure); (d) thyristor currents showing eventual failure; and (e) voltage across a thyristor in the inversion mode, $\alpha > 90^\circ$.

The mean output voltage V_o^γ is therefore

$$V_o^\gamma = V_o - \bar{v}_\gamma$$

$$= \frac{1}{2\pi/3} \left[\int_{\alpha+\pi/6}^{\alpha+5\pi/6} v_2 d\omega t - \int_{\alpha+\pi/6}^{\gamma+\alpha+\pi/6} v_1 d\omega t \right]$$

where $v_\gamma = \frac{1}{2}(v_1 + v_2)$

$$V_o^\gamma = \frac{3}{2\pi} \left[\int_{\alpha+\pi/6}^{\alpha+5\pi/6} \sqrt{2} V \sin(\omega t + \alpha) d\omega t - \int_{\alpha+\pi/6}^{\gamma+\alpha+\pi/6} \sqrt{2} V \{ \sin(\omega t + 2\pi/3) + \sin \omega t \} d\omega t \right]$$

$$v_2 - v_1 = 2L di / dt$$

$$V_o^\gamma = \frac{3}{2\pi} \sqrt{3} \sqrt{2} V \cos \alpha - \frac{3}{2\pi} \frac{\sqrt{3}}{2} \sqrt{2} V (\cos \alpha - \cos(\alpha - \gamma)) \tag{14.191}$$

$$V_o^\gamma = \frac{3\sqrt{3}}{4\pi} \sqrt{2} V [\cos \alpha + \cos(\alpha + \gamma)] = \frac{1}{2} V_o [\cos \alpha + \cos(\alpha + \gamma)] \tag{14.192}$$

which reduces to equation (14.134) when $\gamma=0$. Substituting $\cos \alpha - \cos(\alpha + \gamma)$ from equation (14.190) into equation (14.191) yields

$$V_o^\gamma = \frac{3\sqrt{3}}{2\pi} \sqrt{2} V \cos \alpha - \frac{3}{2\pi} \omega L I_o = V_o - \frac{3}{2\pi} \omega L I_o \quad \text{where } V_o = \frac{3\sqrt{3}}{2\pi} \sqrt{2} V \tag{14.193}$$

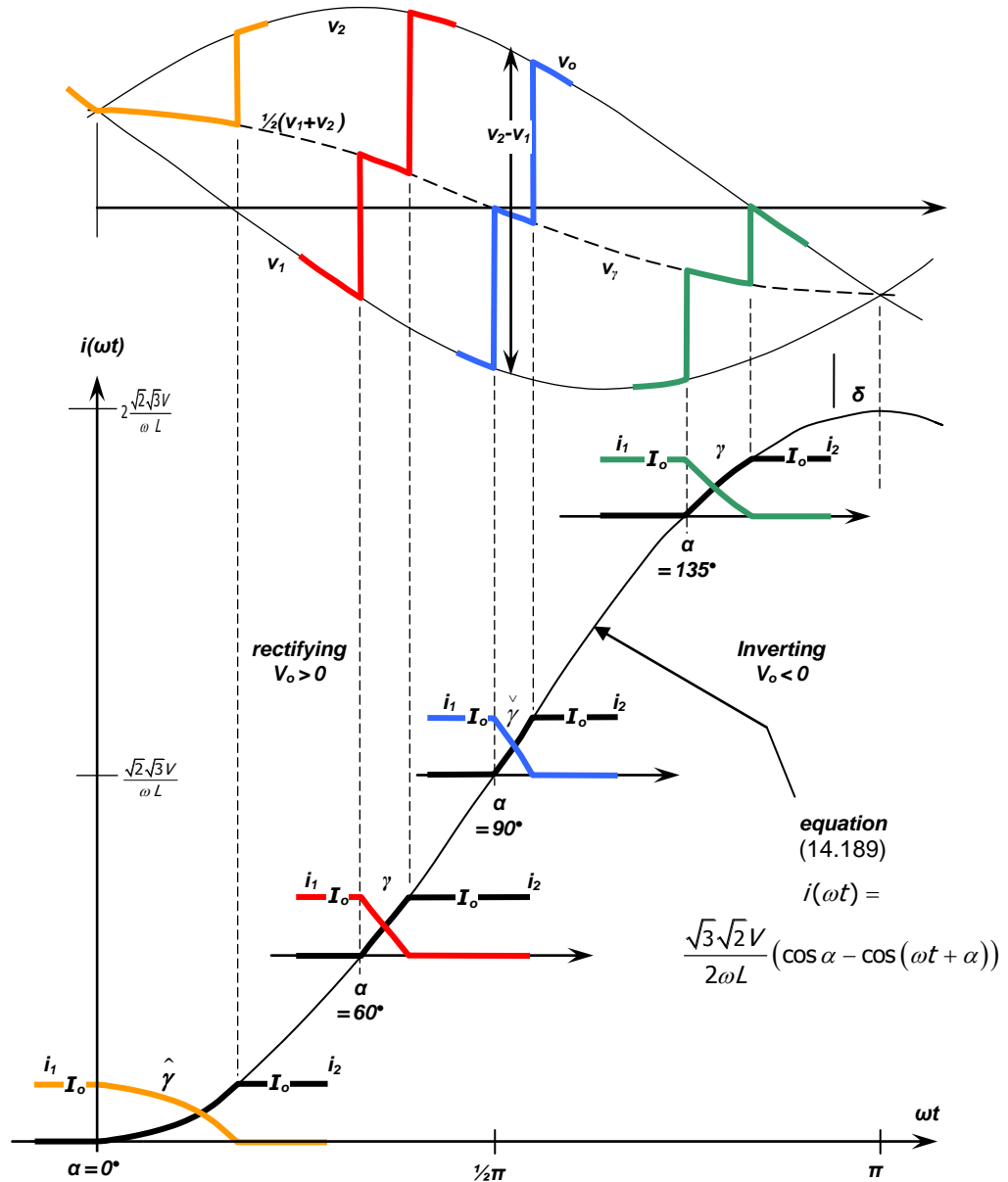

Figure 14.20. Overlap γ for current commutation from thyristor 1 to thyristor 2, at delay angle α .

From equation (14.190) the commutation angle γ is

$$\gamma = \cos^{-1} \left(\cos \alpha - \frac{2\omega L}{\sqrt{3}\sqrt{2}V} I_o \right) - \alpha = \cos^{-1} \left(\cos \alpha - \frac{3\omega L}{2\pi V_o} I_o \right) - \alpha \quad (14.194)$$

The displacement power factor angle is displaced by half the overlap angle, that is

$$DPF = \cos \phi_1 = \cos(\alpha + 1/2\gamma) \quad (14.195)$$

while the overall power factor is

$$pf = DPF \times DF = \frac{\cos(\alpha + 1/2\gamma)}{\sqrt{1 + THD^2}} \quad (14.196)$$

The mean output voltage V_o is reduced or regulated by the commutation reactance $X_c = \omega L$ and this regulation varies with load current magnitude I_o . Converter semiconductor voltage drops also regulate (decrease) the output voltage.

The component $3\omega L/2\pi$ is called the *equivalent internal resistance*. Being an inductive phenomenon, it does not represent a power loss component.

As shown in figure 14.20, the overlap occurs immediately after the delay α . The commutation voltage, $v_2 - v_1$, is $\sqrt{3}\sqrt{2}V \sin \alpha$. The commutation time is inversely proportional to the commutation voltage $v_2 - v_1$.

For rectification, as α increases from zero to $1/2\pi$, the commutation voltage increases from a minimum of zero volts to a maximum of $\sqrt{3}\sqrt{2}V$ at $1/2\pi$, whence the overlap angle γ decreases from a maximum of $\hat{\gamma}$ at $\alpha = 0$ to a minimum of $\check{\gamma}$ at $1/2\pi$.

[For inversion, the overlap angle γ decreases from a minimum of $\check{\gamma}$ at $1/2\pi$ to a maximum of $\hat{\gamma}$ at π , as the commutation voltage reduces from a maximum, back to zero volts.]

From equation (14.190), with $\alpha = \pi$

$$\check{\gamma} = \arcsin(2\omega L I_o / \sqrt{2}\sqrt{3}V)$$

The general expressions for the mean load voltage V_o^γ of an n -pulse, fully-controlled converter, with underlap, are given by

$$V_o^\gamma = \frac{\sqrt{2}V}{2\pi/n} \sin \pi/n [\cos \alpha + \cos(\alpha + \gamma)] \quad (14.197)$$

and

$$V_o^\gamma = \frac{\sqrt{2}V}{\pi/n} \sin \pi/n \cos \alpha \mp nX_c I_o / 2\pi \quad (14.198)$$

where V is the line voltage for a full-wave converter and the phase voltage for a half-wave converter. The plus sign in equation (14.198) accounts for inversion operation.

Effectively, as shown in figure 14.21, during rectification, overlap reduces the mean output voltage by nLI_o or as if α were increased. The supply voltage is effectively distorted and the harmonic content of the output is increased. Equating equations (14.197) and (14.198) gives the mean output current

$$I_o = \frac{\sqrt{2}V}{X_c} \sin \pi/n (\cos \alpha - \cos(\gamma + \alpha)) \quad (A) \quad (14.199)$$

which reduces to equation (14.190) when $n = 3$.

Harmonic input current magnitudes are decreased by a factor $\sin(1/2n\gamma) / 1/2n\gamma$.

In the three-phase case, for a constant dc link current I_o , without commutation effects, the rms phase current and the magnitude of the n^{th} current harmonic are

$$I_{rms} = \frac{\sqrt{2}I_o}{\sqrt{3}} \quad I_{hn} = I_o \frac{2\sqrt{3}}{n\pi} \quad (14.200)$$

When accounting for commutation reactance effects the fundamental current is

$$I_{h1} = I_o \frac{2\sqrt{3}}{\pi} \frac{\left[\cos 2\alpha - \cos 2(\alpha + \gamma) \right]^2 + \left[2\gamma + \sin 2\alpha - \sin 2(\alpha + \gamma) \right]^2}{4 \left[\cos \alpha - \cos(\alpha + \gamma) \right]} \quad (14.201)$$

The single-phase, full-wave, converter voltage drop is $2\omega LI_o/\pi$ and the overlap output voltage is zero.

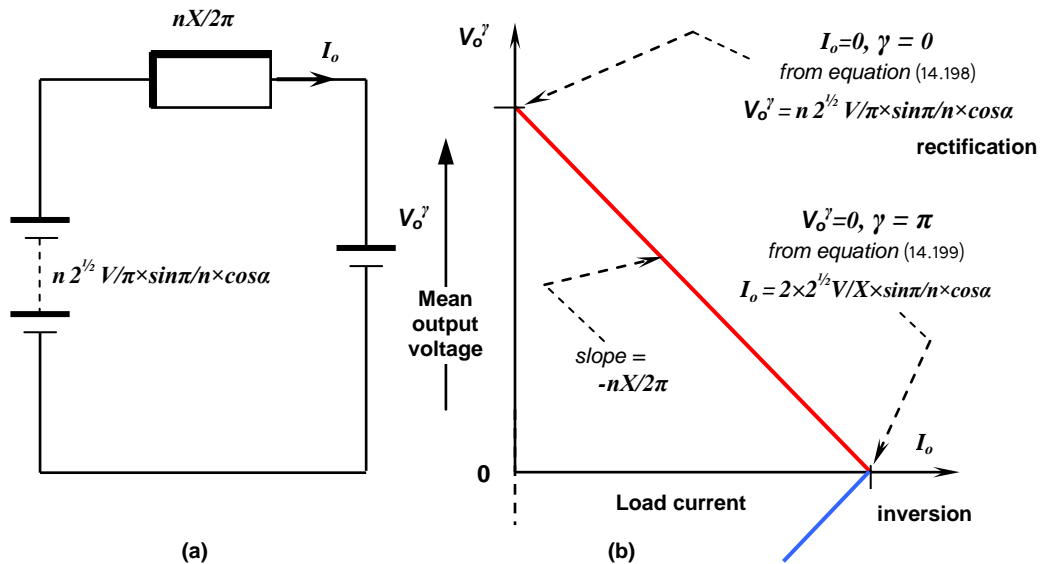

Figure 14.21. Overlap regulation model: (a) equivalent circuit and (b) load plot of overlap model.

The general effects of line inductance, which causes current overlap are:

- the average output voltage is reduced
- the input voltage is distorted – notching in the ac voltage
- the inversion safety angle to allow for thyristor commutation, is increased
- the output voltage spectrum component frequencies are unchanged but there magnitudes are decreased slightly
- thyristor di/dt is reduced.

Table 14.2. Summary of overlap effects on rectifier circuits

configuration	single-phase full-wave	single-phase bridge	three-phase half-wave	three-phase bridge	n -pulse rectifier
ΔV_c	$\frac{X_c}{\pi} I_o$	$\frac{2X_c}{\pi} I_o$	$\frac{3X_c}{2\pi} I_o$	$\frac{3X_c}{\pi} I_o$	$\frac{nX_c}{2\pi} I_o$
$\cos \alpha - \cos(\gamma + \alpha)$	$\frac{I_o X_c}{\sqrt{2}V}$	$\frac{2I_o X_c}{\sqrt{2}V}$	$\frac{2I_o X_c}{\sqrt{6}V}$	$\frac{2I_o X_c}{\sqrt{6}V}$	$\frac{I_o X_c}{\sqrt{2}V \sin \frac{\pi}{n}}$

14.6 Overlap - inversion

A **fully controlled** converter operates in the inversion mode when $\alpha > 90^\circ$ and the mean output voltage is negative and less than the load back emf shown in figure 14.19a. Since the direction of the load current I_o is from the supply and the output voltage is negative, energy is being returned, *regenerated* into the supply from the load. Figure 14.22 shows the power flow differences between rectification and inversion.

As α increases, the returned energy magnitude increases. If α plus the necessary overlap γ exceeds $\omega t = \pi$, commutation failure occurs. The output goes positive and the load current builds up uncontrolled. The last commutation with $\alpha \approx \pi$ in figures 14.19c and d results in a commutation failure of thyristor T_1 . Before the circulating inductor current i has reduced to zero, the incoming thyristor T_2 experiences an anode potential which is less positive than that of the thyristor to be commutated T_1 , $v_1 - v_2 < 0$. The incoming device T_2 fails to stay on and conduction continues through T_1 , impressing positive supply cycles across the load. This positive converter voltage aids the load back emf and the load current builds up uncontrolled.

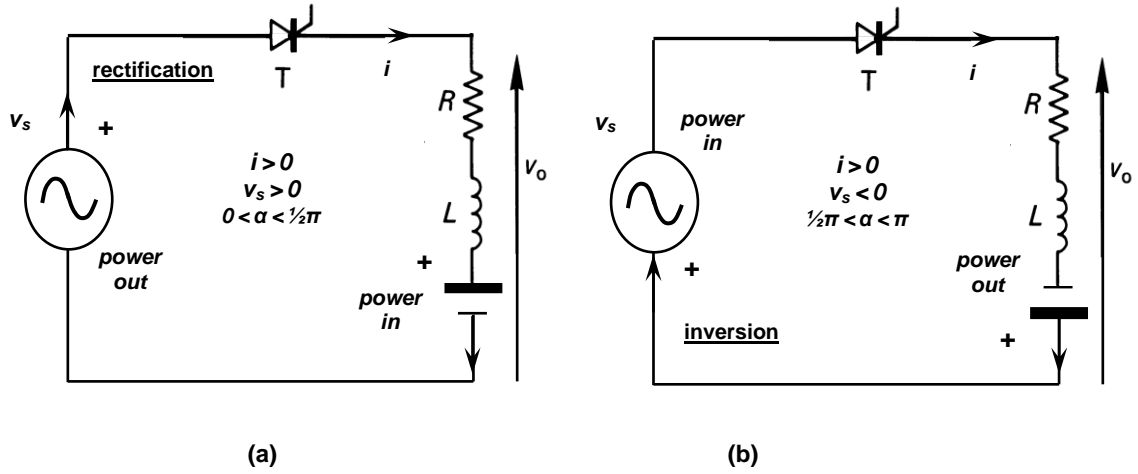

Figure 14.22. Controlled converter model showing:
(a) rectification and (b) inversion.

Analysis of the converter in the inverting mode is similar to its rectifier mode of operation. The same expressions hold for the dc and harmonic components in the output voltage and current. The input supply current Fourier series is also identical. In particular

$$V_o = \frac{3\sqrt{2}}{\pi} V_L \cos \alpha$$

$$i_{a1} = \frac{2\sqrt{3}}{\pi} \bar{I}_o \cos(\omega t - \alpha)$$

Equations (14.197) and (14.198) are valid provided a commutation failure does not occur. The controllable delay angle range is curtailed to

$$0 \leq \alpha \leq \pi - \gamma$$

The maximum allowable delay angle $\hat{\alpha}$ occurs when $\hat{\alpha} + \gamma = \pi$ and from equations (14.197) and (14.198) with $\alpha + \gamma = \pi$ gives

$$\hat{\alpha} = \cos^{-1} \left\{ \frac{X I_o}{\sqrt{2} V \sin \pi / n} - 1 \right\} < \pi \quad (\text{rad}) \quad (14.202)$$

In practice commutation must be complete δ rad before $\omega t = \pi$, in order to allow the outgoing thyristor to regain a forward blocking state. That is $\alpha + \gamma + \delta \leq \pi$. δ is known as the *recovery* or *extinction angle*, and is shown in figure 14.19e. The thyristor recovery period increases with increased anode current and temperature, and decreases with increased voltage.

The input power is equal to the dc power

$$P = \sqrt{3} V I \cos \phi = V_o I_o \quad (14.203)$$

The input power factor is therefore

$$\cos \phi = \frac{V_o I_o}{\sqrt{3} V I} \approx \frac{1}{2} [\cos \alpha + \cos(\alpha + \gamma)] \quad (14.204)$$

See chapter 23 for higher pulse number converters (12 pulse - section 23.4 and 18 pulse - section 23.6).

Example 14.10: Converter overlap

A three-phase full-wave converter is supplied from the 415 V ac, 50 Hz mains with phase source inductance of 0.1 mH. If the average load current is 100 A continuous, for phase delay angles of (i) 0° and (ii) 60° determine

- i. the supply reactance voltage drop,
- ii. mean output voltage (with and without commutation overlap), load resistance, and output power, and
- iii. the overlap angle

Ignoring thyristor forward blocking recovery time requirements, determine the maximum allowable delay angle.

Solution

Using equations (14.197) and (14.198) with $n = 6$ and $V = 415$ V ac, the mean supply reactance voltage

$$\begin{aligned}\bar{v}_\gamma &= \frac{n}{2\pi} 2\pi f L I_o = \frac{6}{2\pi} \times 2\pi 50 \times 10^{-4} \times 10^2 \\ &= 3\text{V}\end{aligned}$$

(i) $\alpha = 0^\circ$ - as for uncontrolled rectifiers. From equation (14.198), the maximum output voltage is

$$\begin{aligned}V_o^\gamma &= \frac{\sqrt{2}V}{2\pi/n} \sin \pi/n \cos \alpha - nX_c I_o / 2\pi \\ &= \frac{\sqrt{2} \times 415}{2\pi/6} \sin \pi/6 \times \cos 0 - 3\text{V} = 560.44\text{V} - 3\text{V} = 557.44\text{V}\end{aligned}$$

where the mean output voltage without commutation inductance effects is 560.4V.

The power output for 100A is $560.4\text{V} \times 100\text{A} = 56.04\text{kW}$ and the load resistance is $560.4\text{V}/100\text{A} = 5.6\Omega$.

From equation (14.197)

$$\begin{aligned}V_o^\gamma &= \frac{\sqrt{2}V}{2\pi/n} \sin \pi/n [\cos \alpha + \cos(\alpha + \gamma)] \\ 557.44 &= \frac{\sqrt{2} \times 415}{2\pi/6} \times \sin \pi/6 \times [1 + \cos \gamma] \\ \text{that is } \gamma &= 8.4^\circ\end{aligned}$$

(ii) $\alpha = 60^\circ$

$$\begin{aligned}V_o^\gamma &= \frac{\sqrt{2}V}{2\pi/n} \sin \pi/n \cos \alpha - nX_c I_o / 2\pi \\ &= \frac{\sqrt{2} \times 415}{2\pi/6} \sin \pi/6 \times \cos 60^\circ - 3\text{V} = 280.22\text{V} - 3\text{V} = 277.22\text{V}\end{aligned}$$

where the mean output voltage without commutation inductance effects is 280.2V.

The power output for 100A is $280.2\text{V} \times 100\text{A} = 28.02\text{kW}$ and the load resistance is $280.2\text{V}/100\text{A} = 2.8\Omega$.

$$\begin{aligned}V_o^\gamma &= \frac{\sqrt{2}V}{2\pi/n} \sin \pi/n [\cos \alpha + \cos(\alpha + \gamma)] \\ 277.22 &= \frac{\sqrt{2} \times 415}{2\pi/6} \times \frac{1}{2} \times [\cos 60^\circ + \cos(60^\circ + \gamma)] \\ \text{that is } \gamma &= 0.71^\circ\end{aligned}$$

Equation (14.202) gives the maximum allowable delay angle as

$$\begin{aligned}\hat{\alpha} &= \cos^{-1} \left\{ \frac{X I_o}{\sqrt{2}V \sin \pi/n} - 1 \right\} \\ &= \cos^{-1} \left\{ \frac{2\pi 50 \times 10^{-4} \times 10^2}{\sqrt{2} \times 415 \times \frac{1}{2}} - 1 \right\} \\ &= 171.56^\circ \text{ and } V_o^\gamma = -557.41\text{V}\end{aligned}$$

♣

14.7 Summary

General expressions for n -phase converter mean output voltage, V_o

(i) Half-wave and full-wave, fully-controlled converter

$$V_o = \sqrt{2}V \frac{\sin(\pi/n)}{\pi/n} \cos \alpha$$

where V is

the rms line voltage for a full-wave converter or
the rms phase voltage for a half-wave converter.

$\cos \alpha = \cos \psi$, the supply displacement factor
 From L'Hopital's rule, for $n \rightarrow \infty$, $V_o = \sqrt{2} V \cos \alpha$

(ii) Full-wave, half-controlled converter

$$V_o = \sqrt{2} V \frac{\sin(\pi/n)}{\pi/n} (1 + \cos \alpha)$$

where V is the rms line voltage.

(iii) Half-wave and full-wave controlled converter with load freewheel diode

$$V_o = \sqrt{2} V \frac{\sin(\pi/n)}{\pi/n} \cos \alpha \quad 0 < \alpha < \pi/2 - \pi/n$$

$$V_o = \sqrt{2} V \frac{1 + \cos(\alpha + \pi/2 - \pi/n)}{2\pi/n} \quad \pi/2 - \pi/n < \alpha < \pi/2 + \pi/n$$

the output rms voltage is given by

$$V_{rms} = V \sqrt{1 + \frac{\cos 2\alpha \sin 2\pi/n}{2\pi/n}} \quad \alpha + \pi/n \leq \pi/2$$

$$V_{rms} = V \sqrt{\frac{1}{2} + \frac{n}{4} - \frac{\alpha}{2\pi/n} - \frac{\cos(2\alpha - 2\pi/n)}{4\pi/n}} \quad \alpha + \pi/n > \pi/2$$

where V is

the rms line voltage for a full-wave converter or
 the rms phase voltage for a half-wave converter.

- $n = 0$ for single-phase and three-phase half-controlled converters
- $= \frac{1}{6}\pi$ for three-phase half-wave converters
- $= \frac{1}{3}\pi$ for three-phase fully controlled converters

These voltage output characteristics are shown in figure 14.23 and the main converter circuit characteristics are shown in table 14.2.

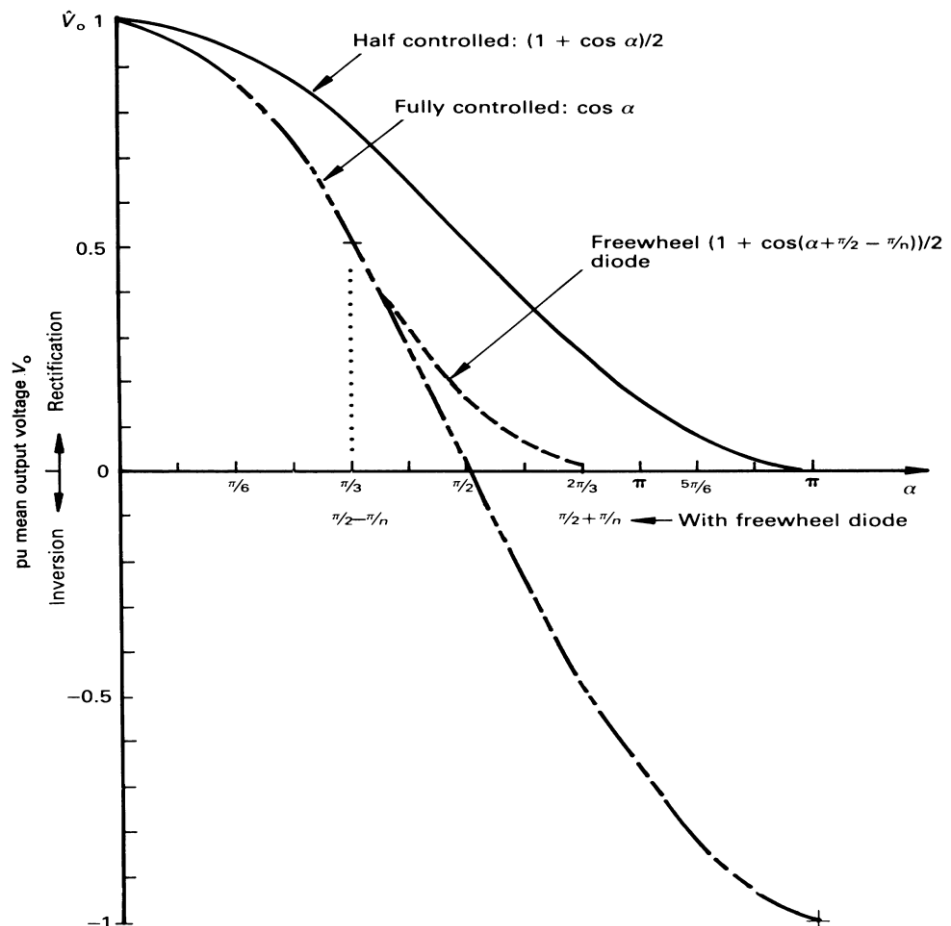

Figure 14.23. Converter normalised output voltage characteristics as a function of firing delay angle α .

14.8 Definitions (see Chapter 13.6) V_o average output voltage \bar{I}_o average output current V_{rms} rms output voltage I_{rms} rms output current \hat{V} peak output voltage \hat{I} peak output current

$$\text{Load voltage form factor} = FF_v = \frac{V_{rms}}{V_o} \quad \text{Load voltage crest factor} = CF_v = \frac{\hat{V}}{V_{rms}}$$

$$\text{Load current form factor} = FF_i = \frac{I_{rms}}{\bar{I}_o} \quad \text{Load current crest factor} = CF_i = \frac{\hat{I}}{I_{rms}}$$

$$\text{Rectification efficiency} = \eta = \frac{\text{dc load power}}{\text{ac load power} + \text{rectifier losses}}$$

$$= \frac{V_o \bar{I}_o}{V_{rms} I_{rms} + \text{Loss}_{\text{rectifier}}}$$

$$\text{Waveform smoothness} = \text{Ripple factor} = RF_v = \frac{\text{effective values of ac } V \text{ (or } I\text{)}}{\text{average value of } V \text{ (or } I\text{)}} = \frac{V_{Ri}}{V_o}$$

$$= \sqrt{\frac{V_{rms}^2 - V_o^2}{V_o^2}} = \sqrt{FF_v^2 - 1}$$

$$\text{where} \quad V_{Ri} = \left[\sum_{n=1}^{\infty} \frac{1}{2} (v_{an}^2 + v_{bn}^2) \right]^{1/2}$$

$$\text{similarly the current ripple factor is } RF_i = \frac{I_{Ri}}{\bar{I}_o} = \sqrt{FF_i^2 - 1}$$

$$RF_i = RF_v \text{ for a resistive load}$$

14.9 Output pulse number

Output pulse number p is the number of pulses in the output voltage that occur during one ac input cycle, of frequency f_s . The pulse number p therefore specifies the output harmonics, which occur at $px f_s$, and multiples of that frequency, $m \times px f_s$, for $m = 1, 2, 3, \dots$

$$p = \frac{\text{period of input supply voltage}}{\text{period of minimum order harmonic in the output } V \text{ or } I \text{ waveform}}$$

The pulse number p is specified in terms of:

- q the number of elements in the commutation group
- r the number of parallel connected commutation groups
- s the number of series connected (phase displaced) commutating groups

Parallel connected commutation groups, r , are usually associated with (and identified by) intergroup reactors (to reduce circulating current), with transformers where at least one secondary is effectively star connected while another is delta connected. The rectified output voltages associated with each transformer secondary, are connected in parallel.

Series connected commutation groups, s , are usually associated with (and identified by) transformers where at least one secondary is effectively star while another is delta connected, with the rectified output associated with each transformer secondary, connected in series.

$q=3 \quad r=2 \quad s=2$ $p=q \times r \times s$ $p=12$
--

The mean converter output voltage V_o can be specified by

$$V_o = s \frac{q}{\pi} \sqrt{2} V_\phi \times \sin \frac{\pi}{q} \times \cos \alpha \quad (14.205)$$

For a full-wave fully-controlled single-phase converter, $r=1$, $q=2$, and $s=1$, whence $p=2$

$$V_o = 1 \times \frac{2}{\pi} \sqrt{2} V_\phi \times \sin \frac{\pi}{2} \times \cos \alpha = \frac{2\sqrt{2} V_\phi}{\pi} \times \cos \alpha$$

For a full-wave, fully-controlled, three-phase converter, $r=1$, $q=3$, and $s=2$, whence $p=6$

$$V_o = 2 \times \frac{3}{\pi} \sqrt{2} V_\phi \times \sin \frac{\pi}{3} \times \cos \alpha = \frac{3\sqrt{2} V_\phi}{\pi} \times \cos \alpha$$

Table 14.3: Main characteristics of controllable converter circuits

Output phase number n and ripple frequency (xf_s):		1	2		3	6		
Type of controlled circuit:			Single-phase bridge			Three-phase bridge		
Text figure number:		Single-phase half-wave 12.2a	Two-phase half-wave 12.7a	Fully controlled 12.6b	Half controlled 12.1	Three-phase half-wave 12.11a	Fully controlled 12.12a	Half controlled 12.10a
Mean output voltage	Maximum output voltage \hat{V}_o $\alpha = 0$ or diode bridge V is rms phase voltage	$\sqrt{2} V/\pi$ (0.45 V)	$2\sqrt{2} V/\pi$	(0.9 V)		$3\sqrt{3} \sqrt{2} V/2\pi$ (1.17 V)	$3\sqrt{3}\sqrt{2} V/\pi$	(2.33 V)
	Normalised controlled mean output voltage V_o/\hat{V}_o	Pure resistive load or with freewheel diode D_f	$\frac{1 + \cos \alpha}{2}$	$\frac{1 + \cos \alpha}{2}$		$0 \leq \alpha \leq \pi/6$ $\cos \alpha$	$0 \leq \alpha \leq \pi/3$ $\cos \alpha$	$\frac{1 + \cos \alpha}{2}$
		Inductive load without D_f		$\cos \alpha$	$\frac{1 + \cos \alpha}{2}$	$\pi/6 < \alpha \leq 5\pi/6$ $\frac{1 + \cos(\alpha + \pi/6)}{\sqrt{3}}$	$\pi/3 < \alpha < 2\pi/3$ $\frac{1 + \cos(\alpha + \pi/3)}{\sqrt{3}}$	
	Text figure no.	12.6a	12.1		12.12	12.15	12.10a	
Equivalent internal resistance $i nX/2\pi$ $X = \omega L$			0.318X	0.637X		0.477X	0.955X	
Output voltage ripple ratio (per cent) ($\alpha = 0, \gamma = 0$)		121	48			19	4.2	
Rectifying device	Average current I_o/n	I_o	$I_o/2$			$I_o/3$	$I_o/3$	
	Peak voltage, $\times V$	$\sqrt{2}$	$2\sqrt{2}$	$\sqrt{2}$		$\sqrt{3}\sqrt{2}$	$\sqrt{3}\sqrt{2}$	I_s
Supply rms currents	Fundamental I_1			$2\sqrt{2} I_o/\pi$	$\frac{2\sqrt{2} I_o}{\pi} \cos \alpha/2$		$\sqrt{6} I_o/\pi$	$\alpha \leq \frac{1}{3} \pi$ $\sqrt{\frac{2}{3}} I_o$
	Total I_s			I_o	$I_o \sqrt{1 - \alpha/\pi}$		$\sqrt{\frac{2}{3}} I_o$	$\alpha \geq \frac{1}{3} \pi$ $\sqrt{\frac{\pi - \alpha}{\pi}} I_o$
Supply factors	Harmonic factor ρ			$\sqrt{\frac{\pi^2}{8} - 1}$	$\frac{\sqrt{\pi(\pi - \alpha)}}{4(1 + \cos \alpha)} - 1$		$\sqrt{\left(\frac{\pi}{3}\right)^2 - 1}$	λ $\alpha \leq \frac{1}{3} \pi$
	Displacement factor, $\cos \psi$			$\cos -\alpha$	$\cos -\alpha/2$		$\cos -\alpha$	$\frac{3}{2\pi}(1 + \cos \alpha)$ $\alpha \geq \frac{1}{3} \pi$
	Power factor λ			$\frac{2\sqrt{2}}{\pi} \cos \alpha$	$\frac{\sqrt{2}(1 + \cos \alpha)}{\sqrt{\pi(\pi - \alpha)}}$		$\frac{3}{\pi} \cos \alpha$	$\frac{\sqrt{3}(1 + \cos \alpha)}{\sqrt{\pi - \alpha}}$

Name	Circuit		Waveforms	Max. Thyristor Voltage	PRV		Maximum Load Voltage $E_d = \text{Average}$ $E_a = \text{RMS}$	Load Voltage with Delayed Firing	Maximum Average Thyristor Current		Maximum Average Diode Current	
	Notation	Schematic			SCR	Diode			Average Amps.	Cond. Period	Average Amps.	Cond. Period
Half-Wave Resistive Load	1-1-1-H			1.4 E_{RMS}	E_p	...	$E_d = \frac{E_p}{\pi}$ $E_a = \frac{E_p}{2}$	$E_d = \frac{E_p}{2\pi} (1 + \cos\alpha)$ $E_a = \frac{E_p}{2\sqrt{\pi}} \sqrt{(\pi - \alpha) + \frac{1}{2} \sin 2\alpha}$	$\frac{E_p}{\pi R}$	180°
Half-Wave Inductive Load with Free Wheeling Diode	1-1-1-H with Free Wheeling Diode			1.4 E_{RMS}	E_p	E_p	$E_d = \frac{E_p}{\pi}$	$E_d = \frac{E_p}{2\pi} (1 + \cos\alpha)$	Highly Ind. Load $\frac{E_p}{2\pi R}$ Conventional $\frac{E_p}{\pi R}$	180°	$\frac{E_p}{\pi R}$	210°
Center Tap Full Wave Resistive Load or Inductive Load with FWD	2-1-1-C			2.8 E_{RMS}	$2E_p$...	$E_d = \frac{2E_p}{\pi}$	$E_d = \frac{E_p}{\pi} (1 + \cos\alpha)$	$\frac{E_p}{\pi R}$	180°	$\frac{2E_p}{\pi R}$	<180°
Center Tap Inductive Load	2-1-1-C			2.8 E_{RMS}	$2E_p$...	$E_d = \frac{2E_p}{\pi}$	$E_d = \frac{2E_p}{\pi} (\cos\alpha)$ $(I_L = K)$	$\frac{E_p}{\pi R}$	180°
Center Tap Inductive Load with FWD Thyristor in DC Circuit	2-1-1-C with Thyristor in DC Circuit			1.4 E_{RMS}	0	2.8 E_{RMS}	$E_d = \frac{2E_p}{\pi}$	$E_d = \frac{E_p}{\pi} (1 + \cos\alpha)$	$\frac{2E_p}{\pi R}$	360°	$\frac{E_p}{\pi R}$	180°
Single Phase Bridge Half Control Resistive or Inductive FWD Load	Half Control 4-1-1-B and FWD			1.4 E_{RMS}	E_p	E_p	$E_d = \frac{2E_p}{\pi}$	$E_d = \frac{E_p}{\pi} (1 + \cos\alpha)$	$\frac{E_p}{\pi R}$	180°	$\frac{E_p}{\pi R}$	180°
Single Phase Bridge Full Control Resistive or Inductive FWD Load	Full Control 4-1-1-B			1.4 E_{RMS}	E_p	...	$E_d = \frac{2E_p}{\pi}$	$E_d = \frac{2E_p}{\pi} (\cos\alpha)$ $(I_L = K)$	$\frac{E_p}{\pi R}$	180°
Single Phase Bridge with Thyristor in DC and Free Wheeling Diode	4-1-1-B with Thyristor Control and FWD			1.4 E_{RMS}	E_p	E_p	$E_d = \frac{2E_p}{\pi}$	$E_d = \frac{E_p}{\pi} (1 + \cos\alpha)$	$\frac{2E_p}{\pi R}$	360°	$\frac{E_p}{\pi R}$	180°
Three Phase Half Wave Inductive Load	3-1-1-Y			2.45 E_{RMS}	2.45 E_{RMS}	...	$E_d = \frac{3\sqrt{3}E_p}{2\pi}$	$E_d = \frac{3\sqrt{3}E_p}{2\pi} (\cos\alpha)$ $(I_L = K)$.33 I _D	120°
Three Phase Half Wave Resistive Load or Inductive Load with Free Wheeling Diode	3-1-1-Y with Free Wheeling Diode			2.45 E_{RMS}	2.45 E_{RMS}	E_p	$E_d = \frac{3\sqrt{3}E_p}{2\pi}$	$E_d = \frac{3\sqrt{3}E_p}{2\pi} (\cos\alpha)$ $(0 < \alpha < 30^\circ)$ $E_d = \frac{3E_p}{2\pi} [1 + \cos(\alpha + 30^\circ)]$ $(30^\circ < \alpha < 150^\circ)$.33 I _D	120°	Size to .33 I _D	<120° FWD
Three Phase Bridge Full Control Inductive Load	6-1-1-B with Full Control			2.45 E_{RMS}	2.45 E_{RMS}	...	$E_d = \frac{3\sqrt{3}E_p}{\pi}$	$E_d = \frac{3\sqrt{3}E_p}{\pi} (\cos\alpha)$.33 I _D	120°
Three Phase Bridge Full Control Resistive Load or Inductive Load with Free Wheeling Diode	6-1-1-B Full Control and FWD			2.45 E_{RMS}	2.45 E_{RMS}	2.45 E_{RMS}	$E_d = \frac{3\sqrt{3}E_p}{\pi}$	$E_d = \frac{3\sqrt{3}E_p}{\pi} (\cos\alpha)$ $(0 < \alpha < 60^\circ)$ $E_d = \frac{3\sqrt{3}E_p}{\pi} \left(1 + \frac{\cos\alpha}{2} + \frac{\sqrt{3}}{2} \sin\alpha \right)$ $(60^\circ < \alpha < 120^\circ)$.33 I _D	120°	Size to .33 I _D	<120° FWD
Three Phase Bridge Half Control Resistive Load or Inductive Load with Free Wheeling Diode	6-1-1-B Half Control and FWD			2.45 E_{RMS}	2.45 E_{RMS}	2.45 E_{RMS}	$E_d = \frac{3\sqrt{3}E_p}{\pi}$	$E_d = \frac{3\sqrt{3}E_p}{2\pi} (1 + \cos\alpha)$.33 I _D	120°	Size to .33 I _D	<120° FWD
Inverse Parallel Thyristors Resistive Load	AC Switch			1.4 E_{RMS}	E_p	...	$E_d = \frac{E_p}{1.4}$	$E_d = \frac{E_p}{2\sqrt{\pi}} \sqrt{(\pi - \alpha) + \frac{1}{2} \sin 2\alpha}$	$\frac{E_p}{\pi R}$	180°

14.10 AC-dc converter generalised equations

Alternating sinusoidal voltages

$$V_1 = \sqrt{2} V \sin \omega t$$

$$V_2 = \sqrt{2} V \sin \left(\omega t - \frac{2\pi}{q} \right)$$

$$\vdots$$

$$V_q = \sqrt{2} V \sin \left(\omega t - (q-1) \frac{2\pi}{q} \right)$$

where q is the number of phases (number of voltage sources)

On the secondary or converter side of any transformer, if the load current is assumed constant I_o then the power factor is determined by the load voltage harmonics.

Voltage form factor

$$FF_v = \frac{V_{rms}}{V_o}$$

whence the voltage ripple factor is

$$RF_v = \frac{1}{V_o} [V_{rms}^2 - V_o^2]^{1/2} = [FF_v^2 - 1]^{1/2}$$

The power factor on the secondary side of any transformer is related to the voltage ripple factor by

$$pf = \frac{P_d}{S} = \frac{V_o I_o}{q V I_{rms}} = \frac{1}{\sqrt{RF_v^2 + 1}}$$

On the primary side of a transformer the power factor is related to the secondary power factor, but since the supply is assumed sinusoidal, the power factor is related to the primary current harmonics.

Relationship between current ripple factor and power factor

$$RF_i = \frac{1}{I_1} \sqrt{\sum_{h=3}^{\infty} I_h^2} = \frac{1}{I_1} \sqrt{I_{rms}^2 - I_1^2}$$

$$pf = \frac{I_1}{I_{rms}} = \frac{1}{\sqrt{1 + RF_i^2}}$$

The supply power factor is related to the primary power factor and is dependent of the supply connection, star or delta, etc.

Half-wave controlled rectifiers – star connected secondary supply [see figures 14.4, 14.11]

q phases and q thyristors, and a phase delay angle of α . The pulse number is $p (=q)$.

Mean output voltage is

$$V_o = \frac{q}{2\pi} \int_{\frac{1}{2}\pi - \frac{\pi}{q} + \alpha}^{\frac{1}{2}\pi + \frac{\pi}{q} + \alpha} \sqrt{2} V \sin \omega t \, d\omega t$$

$$= \frac{q}{\pi} \sqrt{2} V \sin \frac{\pi}{q} \cos \alpha$$

$$= V_o(\alpha = 0) \cos \alpha$$

The rms output voltage is

$$V_{rms} = \frac{q}{2\pi} \int_{\frac{1}{2}\pi - \frac{\pi}{q} + \alpha}^{\frac{1}{2}\pi + \frac{\pi}{q} + \alpha} (\sqrt{2} V \sin \omega t)^2 \, d\omega t$$

$$= \sqrt{2} V \left[\frac{1}{2} + \frac{q}{4\pi} \sin \frac{2\pi}{q} \cos \alpha \right]^{1/2}$$

The maximum and minimum voltages in the output are

$$\hat{v} = \sqrt{2} V \quad \text{for } 0 < \alpha < \frac{\pi}{q}$$

$$= \sqrt{2} V \cos \left(-\frac{\pi}{q} + \alpha \right) \quad \text{for } \alpha > \frac{\pi}{q}$$

$$\check{v} = \sqrt{2} V \cos \left(\frac{\pi}{q} + \alpha \right) \quad \text{for } \alpha < \frac{3\pi}{2} + \frac{\pi}{q}$$

$$= -\sqrt{2} V \quad \text{for } \alpha > \frac{3\pi}{2} + \frac{\pi}{q}$$

Normalised peak to peak ripple voltage and amplitude of the output harmonics are

$$V_{n_{p-p}} = \frac{V_{p-p}}{V_o} = \frac{\pi}{q} \frac{1 - \cos \frac{\pi}{q}}{\sin \frac{\pi}{q}}$$

$$V_h = \frac{q}{4\pi} \sqrt{2} V \sin \frac{2\pi}{q} |\cos \alpha| \frac{2}{k^2 q^2 - 1} \sqrt{1 + k^2 q^2 \tan^2 \alpha}$$

Diode reverse voltage

$$\begin{aligned} \hat{V}_{D_R} &= 2\sqrt{2} V \quad q \text{ even} \\ \hat{V}_{D_R} &= 2\sqrt{2} V \cos \frac{\pi}{2q} \quad q \text{ odd} \end{aligned}$$

The thyristor currents are the same as the equivalent diode circuit

Power factor (is related to the equivalent diode circuit)

$$pf = \frac{\sqrt{2} q}{\pi} \sin \frac{\pi}{q} \cos \alpha = pf_{\alpha=0} \cos \alpha$$

Overlap angle and inductive voltage

$$\begin{aligned} \cos \alpha - \cos(\alpha + \mu) &= \frac{\omega L_c I_o}{\sqrt{2} V \sin \frac{\pi}{q}} \\ v_{com} &= \frac{q}{2\pi} \omega L_c I_o \end{aligned}$$

Time domain equations, for an R - L load

$$L \frac{di}{dt} + Ri = \sqrt{2} V \cos \omega t \quad (V)$$

Continuous current

$$i(\omega t) = \frac{\sqrt{2} V}{Z} \cos(\omega t - \phi) + \left\{ i_o - \frac{\sqrt{2} V}{Z} \cos\left(-\frac{\pi}{p} + \alpha - \phi\right) e^{\left(-\frac{\pi}{p} + \alpha - \omega t\right)/\tan \phi} \right\}$$

where $Z = \sqrt{R^2 + \omega^2 L^2}$ (ohms)

$$\tan \phi = \omega L / R$$

where

$$i_o = \frac{\sqrt{2} V}{R \sec^2 \phi} \times \frac{\cos\left(\frac{\pi}{p} + \alpha\right) + \tan \phi \sin\left(\frac{\pi}{p} + \alpha\right) - \left[\cos\left(\frac{\pi}{p} - \alpha\right) - \tan \phi \sin\left(\frac{\pi}{p} - \alpha\right) \right] e^{-\frac{2\pi}{p \tan \phi}}}{1 - e^{-\frac{2\pi}{p \tan \phi}}}$$

with an average value of

$$I_o = \frac{V_o}{R} = \frac{p}{\pi} \frac{\sqrt{2} V}{R} \sin \frac{\pi}{p} \cos \alpha$$

Discontinuous current

Boundary condition

$$\tan \alpha = \frac{\tan \phi \tan \frac{\pi}{p} + \tanh \frac{\pi}{p \tan \phi}}{\tan \frac{\pi}{p} - \tan \phi \tanh \frac{\pi}{p \tan \phi}}$$

$$i(\omega t) = \frac{\sqrt{2} V}{R \sec^2 \phi} \left\{ \cos \omega t + \tan \phi \sin \omega t + \left[\cos\left(\frac{\pi}{p} - \alpha\right) - \tan \phi \sin\left(\frac{\pi}{p} - \alpha\right) \right] e^{\left(-\frac{\pi}{p} + \alpha - \omega t\right)/\tan \phi} \right\}$$

The average output voltage is dependent on the current extinction angle, β

$$V_o = \frac{p}{2\pi} \sqrt{2} V \left[\sin \beta - \sin\left(-\frac{\pi}{p} + \alpha\right) \right]$$

Half-wave controlled rectifiers, with freewheel diode [see figures 14.6, 14.12]

q phases q thyristors and 1 diode

$$v(\omega t) = \sqrt{2}V \cos \omega t \quad \text{for } -\frac{\pi}{p} + \alpha < \omega t < \frac{\pi}{p} + \alpha$$

$$= 0 \quad \text{for } \frac{\pi}{2} < \omega t < \frac{\pi}{p} + \alpha$$

where the earliest conduction point is

$$\alpha > \frac{1}{2}\pi - \frac{\pi}{p}$$

Mean rectified output voltage is

$$V_o = \frac{p}{2\pi} \int_{-\pi/4+\alpha}^{1/2\pi} \sqrt{2}V \cos \omega t \, d\omega t$$

$$= \frac{p}{2\pi} \sqrt{2}V \left[1 - \sin\left(-\frac{\pi}{p} + \alpha\right) \right]$$

RMS voltage

$$V_{rms} = \sqrt{2}V \left[\frac{1}{4} - \frac{p}{8} - \frac{p\alpha}{4\pi} + \frac{p}{8\pi} \sin\left(2\alpha - \frac{2\pi}{q}\right) \right]^{1/2}$$

The maximum ripple occurs at $\omega t = -\frac{\pi}{p} + \alpha$, with zero volts during diode freewheeling, thus

$$v_{p-p} = \sqrt{2}V \cos\left(\frac{\pi}{p} - \alpha\right) - 0$$

$$V_{n_{p-p}} = \frac{v_{p-p}}{\hat{V}_o} = \frac{\sqrt{2}V \cos\left(\frac{\pi}{p} - \alpha\right)}{\frac{p}{2\pi} \sqrt{2}V \left(1 - \sin\left(\frac{\pi}{p} - \alpha\right)\right)} = \frac{2\pi}{p} \frac{\cos\left(\frac{\pi}{p} - \alpha\right)}{1 + \sin\left(\frac{\pi}{p} - \alpha\right)}$$

The freewheel diodes conduct for p periods of duration $\pi/p + \alpha$, and the currents are

$$\bar{I}_{Df} = \bar{I}_o \left(\frac{1}{2} + \frac{p\alpha}{2\pi} - \frac{1}{4}p \right)$$

$$I_{rmsDf} = \bar{I}_o \left(\frac{1}{2} + \frac{p\alpha}{2\pi} - \frac{1}{4}p \right)^{1/2}$$

The thyristor conducts for $2\pi/p$ without a load freewheel diode and $2\pi/p - (\pi/p + \alpha + \frac{1}{2}\pi)$ when the diode is present. The thyristor rms current is

$$I_{rmsTh} = \frac{I_o}{\sqrt{q}} \left[\frac{1}{2} - \frac{p\alpha}{2\pi} + \frac{1}{4}p \right]^{1/2}$$

Full-wave fully controlled thyristor converters—star connected supply [see figures 14.7, 14.8, 14.9, 14.13]

q phases $2q$ thyristors

Pulse number, p

$$p=q \quad \text{if } q \text{ is even}$$

$$p=2q \quad \text{if } q \text{ is odd}$$

Mean voltage

$$V_o = \frac{p}{\pi} \hat{V} \sin \frac{\pi}{p} \cos \alpha = V_o' \cos \alpha$$

The rms output voltage is

$$V_{o,rms} = \hat{V} \left[\frac{1}{2} + \frac{p}{4\pi} \sin \frac{2\pi}{p} \cos \alpha \right]^{1/2}$$

The maximum and minimum voltages in the output are

$$\begin{aligned}\hat{v} &= \hat{V} && \text{for } 0 < \alpha < \frac{\pi}{\rho} \\ &= \hat{V} \cos\left(-\frac{\pi}{\rho} + \alpha\right) && \text{for } \alpha > \frac{\pi}{\rho} \\ \check{v} &= \hat{V} \cos\left(\frac{\pi}{\rho} + \alpha\right) && \text{for } \alpha < \frac{3\pi}{2} + \frac{\pi}{\rho} \\ &= -\hat{V} && \text{for } \alpha > \frac{3\pi}{2} + \frac{\pi}{\rho}\end{aligned}$$

where

$$\begin{aligned}\hat{V} &= \frac{\pi}{\rho} \frac{1}{\sin \frac{\pi}{\rho}} \times V_o' \\ V_o' &= \frac{2q}{\pi} \sqrt{2} V \sin \frac{\pi}{q}\end{aligned}$$

Thyristor maximum reverse and forward voltage

$$\begin{aligned}\hat{V}_R &= 2\sqrt{2} V && q \text{ even} \\ \hat{V}_R &= 2\sqrt{2} V \cos \frac{\pi}{2q} && q \text{ odd}\end{aligned}$$

RMS currents and power factor

$$\begin{aligned}I_{TH} &= \frac{I_o}{q} && I_{TH\ rms} = I_o \sqrt{\frac{2}{q}} \\ pf &= \frac{q}{\pi} \sin \frac{\pi}{q} \cos \alpha = pf_{\alpha=0} \cos \alpha\end{aligned}$$

Overlap angle and inductive voltage

$$\begin{aligned}\cos \alpha - \cos(\alpha - \mu) &= \frac{\omega L_c I_o}{\sqrt{2} V \sin \frac{\pi}{q}} \\ V_{com} &= \frac{q}{\pi} \omega L_c I_o\end{aligned}$$

Half-controlled full bridges – star connected secondary [see figures 14.1, 14.10, 14.17]

q phases q thyristors and q diodes, each of which conduct for $2\pi/q$

Pulse number

$$p=q \quad \text{for all } q, \text{ odd or even}$$

Mean voltage

$$\begin{aligned}V_o &= \frac{q}{\pi} \sqrt{2} V \sin \frac{\pi}{q} (1 + \cos \alpha) \\ &= V_o' \frac{1 + \cos \alpha}{2} \\ \text{where } V_o' &= \frac{2q}{\pi} \sqrt{2} V \sin \frac{\pi}{q}\end{aligned}$$

Thyristor and diode reverse voltage

$$\begin{aligned}\hat{V}_R &= 2\sqrt{2} V && q \text{ even} \\ \hat{V}_R &= 2\sqrt{2} V \cos \frac{\pi}{2q} && q \text{ odd}\end{aligned}$$

Power factor

$$\begin{aligned}I_s &= I_o \sqrt{\frac{2}{q}} && pf = \frac{2}{\pi} \sqrt{q} \sin \frac{\pi}{q} \frac{1 + \cos \alpha}{2} && \alpha < \pi - \frac{2\pi}{q} \\ I_s &= I_o \left(1 - \frac{\alpha}{\pi}\right)^{1/2} && pf = \frac{\sqrt{2}}{\pi} \sin \frac{\pi}{q} (1 + \cos \alpha) \left(\frac{\pi}{\pi - \alpha}\right)^{1/2} && \alpha > \pi - \frac{2\pi}{q}\end{aligned}$$

Full-wave fully-controlled bridges – delta connected secondary supply

Pulse number in the rectified output is

$$\begin{aligned} p &= q && \text{for } q \text{ even} \\ p &= 2q && \text{for } q \text{ odd} \end{aligned}$$

Thyristor maximum forward and reverse voltages

$$\begin{aligned} \hat{V}_R &= \frac{2\sqrt{2}V}{\frac{q}{\pi} \sin \frac{\pi}{q}} && q \text{ even} \\ \hat{V}_R &= \frac{2\sqrt{2}V \cos \frac{\pi}{2q}}{\frac{q}{\pi} \sin \frac{\pi}{q}} && q \text{ odd} \end{aligned}$$

The power factor is the same as for the star case.

Half-controlled full bridges – delta connected secondary supply

In terms of the semiconductors and rectified voltage star and mesh behave the same.

Mean voltage, for all q is

$$\begin{aligned} V_o &= \frac{q}{\pi} \sqrt{2}V \sin \frac{\pi}{q} (1 + \cos \alpha) \\ &= V_o' \frac{1 + \cos \alpha}{2} \\ \text{where } V_o' &= \frac{2q}{\pi} \sqrt{2}V \sin \frac{\pi}{q} \end{aligned}$$

For a 3-phase half-controlled converter, the secondary current is

$$I_s = \frac{I_o}{\sqrt{3}} \left(1 - \frac{\alpha}{\pi} \right)^{1/2}$$

For large q , $q > 6$

$$\begin{aligned} I_s &= \frac{I_o}{\sqrt{3}} \left(1 - \left(\frac{\alpha}{\pi} \right)^2 \right)^{1/2} \\ pf &= \frac{\sqrt{2}}{\pi} \frac{1 + \cos \alpha}{\pi \left(1 - \left(\frac{\alpha}{\pi} \right)^2 \right)^{1/2}} \end{aligned}$$

Reading list

Dewan, S. B. and Straughen, A., *Power Semiconductor Circuits*, John Wiley and Sons, New York, 1975.

Sen, P.C., *Power Electronics*, McGraw-Hill, 5th reprint, 1992.

Shepherd, W *et al.* *Power Electronics and motor control*, Cambridge University Press, 2nd Edition 1995.

<http://www.ipes.ethz.ch/>

Problems

- 14.1. For the circuit shown in figure 14.24, if the thyristor is fired at $\alpha = \frac{1}{3}\pi$
- derive an expression for the load current, i
 - determine the current extinction angle, β
 - determine the peak value and the time at which it occurs
 - sketch to scale on the same ωt axis the supply voltage, load voltage, thyristor voltage, and load current.

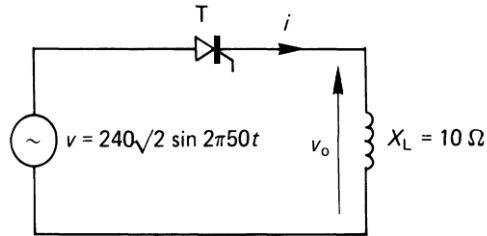

Figure 14.24. Problem 14.1.

- 14.2. For the circuit shown in figure 14.25, if the thyristor is fired at $\alpha = \frac{1}{4}\pi$ determine
- the current extinction angle, β
 - the mean and rms values of the output current
 - the power delivered to the source E .
 - sketch the load current and load voltage v_o .

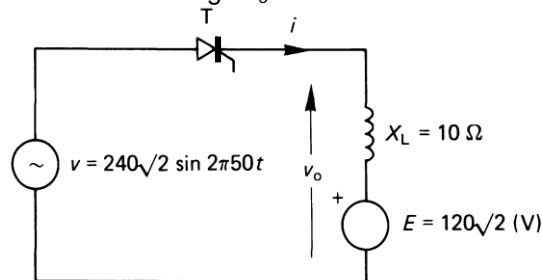

Figure 14.25. Problem 14.2.

- 14.3. Assuming a constant load current derive an expression for the mean and rms device current and the device form factor, for the circuit in figure 14.1.
- 14.4. Plot load ripple voltage K_{Rl} and load voltage ripple factor RF_v , against the thyristor phase delay angle α for the circuit in figure 14.1.
- 14.5. Show that the average output voltage of a n -phase half-wave controlled converter with a freewheel diode is characterised by
- $$V_o = \sqrt{2}V \frac{\sin(\pi/n)}{\pi/n} \cos \alpha \quad (\text{V})$$
- $$0 < \alpha < \frac{1}{2} - \pi/n$$
- $$V_o = \sqrt{2}V \frac{1 + \cos \alpha + \frac{1}{2}\pi - \frac{1}{n}\pi}{2\pi/n} \quad (\text{V})$$
- $$\frac{1}{2}\pi - \frac{1}{n}\pi < \alpha < \frac{1}{2}\pi + \frac{1}{n}\pi$$
- 14.6. Draw the load voltage and current waveforms for the circuit in figure 14.6a when a freewheel diode is connected across the load. Specify the load rms voltage.
- 14.7. The converter in figure 14.6a, with a freewheel diode, is operated from the 240 V, 50 Hz supply. The load consists of, series connected, a 10 Ω resistor, a 5 mH inductor and a 40 V battery. Derive the load voltage expression in the form of a Fourier series. Determine the rms value of the fundamental of the load current.

- 14.8. Show that the average output voltage of a single-phase fully controlled converter is given by

$$V_o = \frac{2\sqrt{2}V}{\pi} \cos \alpha$$

Assume that the output current I_o is constant.

Prove that the supply current Fourier coefficients are given by

$$a_n = -\frac{4I_o}{n\pi} \sin n\alpha \quad b_n = \frac{4I_o}{n\pi} \cos n\alpha$$

for n odd.

Hence or otherwise determine (see section 14.6)

- i. the displacement factor, $\cos \psi$
- ii. the distortion factor, μ
- iii. the total supply power factor λ .

Determine the supply harmonic factor, ρ , if

$$\rho = I_h / I_\ell$$

where I_h is the total harmonic current and I_ℓ is the fundamental current.

- 14.9. Show that the average output voltage of a single-phase half-controlled converter is given by

$$v_o = \frac{\sqrt{2}V}{\pi} (1 + \cos \alpha)$$

Assume that the output current I_o is constant.

- Determine
- i. the displacement factor, $\cos \psi$
 - ii. the distortion factor, μ
 - iii. the total supply power factor, λ .

Show that the supply harmonic factor, ρ (see problem 14.8), is given by

$$\rho = \sqrt{\left[\frac{\pi(\pi - \alpha)}{4(1 + \cos \alpha)} - 1 \right]}$$

- 14.10. A centre tapped transformer, single-phase, full-wave converter (figure 14.7a) with a load freewheel diode is supplied from the 240 V ac, 50 Hz supply with source inductance of 0.25 mH. The continuous load current is 5 A. Find the overlap angles for

- i. the transfer of current from a conducting thyristor to the load freewheel diode and
- ii. from the freewheel diode to a thyristor when the delay angle α is 30° .

$$\gamma_{t-d} = \cos^{-1} \left\{ 1 - \frac{\omega L I_o}{\sqrt{2}V} \right\} = 2.76^\circ;$$

$$\gamma_{t-d} = \cos^{-1} \left\{ \cos \alpha - \frac{\omega L I_o}{\sqrt{2}V} \right\} - \alpha = 0.13^\circ$$

- 14.11. The circuit in figure 14.4a, with $v = \sqrt{2}V \sin(\omega t + \alpha)$, has a steady-state time response of

$$i(\omega t) = \frac{\sqrt{2}V}{Z} \left\{ \sin(\omega t + \alpha - \phi) - \sin(\alpha - \phi) e^{-Rt/L} \right\}$$

where α is the trigger phase delay angle after voltage crossover and $\phi = \tan^{-1}(\omega L / R)$

Sketch the current waveform for $\alpha = \frac{1}{4}\pi$ and Z with

- i. $R \gg \omega L$
- ii. $R = \omega L$
- iii. $R \ll \omega L$.

$$[(\sqrt{2}V/R) \sin(\omega t + \frac{1}{4}\pi); (V/R) \sin \omega t; (V/\omega L) (\sin \omega t - \cos \omega t + 1)]$$

- 14.12. A three-phase, fully-controlled converter is connected to the 415 V supply, which has a reactance of 0.25 Ω /phase and resistance of 0.05 Ω /phase. The converter is operating in the inverter mode with $\alpha = 150^\circ$ and a continuous 50 A load current. Assuming a thyristor voltage drop of 1.5 V at 50 A, determine the mean output voltage, overlap angle, and available recovery angle.

$$[-485.36 \text{ V } -3 \text{ V } -5 \text{ V } -11.94 \text{ V} = -505.3 \text{ V}; 6.7^\circ; 23.3^\circ]$$

- 14.13. For the converter system in problem 14.12, what is the maximum dc current that can be accommodated at a phase delay of 165° , allowing for a recovery angle of 5° ?

$$[35.53 \text{ A}]$$

- 14.14. The single-phase half-wave controlled converter in figure 14.4 is operated from the 240 V, 50 Hz supply and a 10 Ω resistive load. If the mean load voltage is 50 per cent of the maximum mean voltage, determine the (a) delay angle, α , (b) mean and rms load current, and (c) the input power factor.
- 14.15. The converter in figure 14.1a is operated from the 240 V, 50 Hz supply with a load consisting of the series connection of a 10 Ω resistor, a 5 mH inductor, and a 40 V battery. Derive the load voltage expression in the form of a Fourier series. Determine the rms value of the fundamental of the load current.
- 14.16. The converter in figure 14.12 is operated from a Y-connected, 415 V, 50 Hz supply. If the load is 100 A continuous with a phase delay angle of $\pi/6$, calculate the (a) harmonic factor of the supply current, (b) displacement factor $\cos \psi$, and (c) supply power factor, λ .
- 14.17. The converter in figure 14.12 is operated from the 415 V line-to-line voltage, 50 Hz supply, with a series load of 10 Ω + 5 mH + 40 V battery. Derive the load voltage expression in terms of a Fourier series. Determine the rms value of the fundamental of the load current.
- 14.18. Repeat problem 14.17 for the three-phase, half-controlled converter in figure 14.10.
- 14.19. Repeat problem 14.17 for the three-phase, fully-controlled converter in figure 14.13.
- 14.20. The three-phase, half-controlled converter in figure 14.10 is operated from the 415 V, 50 Hz supply, with a 100 A continuous load current. If the line inductance is 0.5 mH/phase, determine the overlap angle γ if (a) $\alpha = \pi/6$ and (b) $\alpha = \frac{2}{3}\pi$.
- 14.21. Repeat *example 14.2* using a 100Vac 60Hz supply.
- 14.22. A fully controlled half-wave rectifier has a resistive 30 Ω and a 240V ac 50Hz voltage source.
- (a) If the delay angle $\alpha = 60^\circ$, determine:
 - i. the average voltage across the load resistor
 - ii. the power absorbed by the load resistor
 - iii. the ac source power factor.
 - (b) If the average load current is 5A determine
 - i. the average voltage across the load
 - ii. the power absorbed by the load
 - iii. the supply power factor.
- 14.23. A fully controlled half-wave rectifier has a 240V ac 50Hz source and a series R - L load of $R = 20\Omega$ and $L = 50\text{mH}$. If the delay angle is $\alpha = 60^\circ$, determine
- i. an expression for the load current
 - ii. the average load current
 - iii. the power absorbed by the load
 - iv. the supply power factor
- 14.24. An electromagnet is modelled by a series R - L circuit with $R=10\Omega$ and $L=100\text{mH}$, and supplied from a 50Hz 240V ac voltage source.
- i. when supplied from a full-wave uncontrolled rectifier, the average current must be 20A to active the magnetic field. What series resistance must be added to increase the average current to 20A?
 - ii. when supplied from a full-wave fully-controlled converter, what delay angle will produce the necessary average current of 20A to activate the electro-magnet?
- 14.25. Show that the power factor for a fully-controlled single-phase full-wave converter with a purely resistive load is given by

$$pf = \sqrt{1 - \frac{\alpha}{\pi} + \frac{\sin 2\alpha}{2\pi}}$$

- 14.26. A fully controlled single-phase full-wave bridge converter has a $60\ \Omega$ resistive load and a 240V ac 50Hz voltage source. If the firing delay angle is $\alpha = 60^\circ$, determine:
- the average load current
 - the rms load current
 - the rms source current
 - the ac source power factor
- 14.27. A three-phase, fully-controlled, converter is supplied from a 3.3kV ac 50Hz source. If the load is a $110\ \Omega$ resistor determine:
- the delay angle which results is an average load current of 20A
 - the amplitude of the first voltage harmonic (at 300Hz)
- 14.28. A three-phase, fully-controlled, converter is supplied from a 3.3kV ac 50Hz source. If the R - L load is $R = 100\ \Omega$ and $L = 100\text{mH}$, and the delay angle is $\alpha = 30^\circ$, determine:
- the average load current
 - the amplitude of the first current harmonic (at 300Hz)
 - the rms phase current from the ac voltage source.

blank