

CHAPTER 13

Naturally Commutating AC to DC Converters

- Uncontrolled Rectifiers

The rectifier converter circuits considered in this chapter have in common an ac voltage supply input and a dc load output. The function of the converter circuit is to convert the ac source energy into fix dc load voltage. Turn-off of converter semiconductor devices is brought about by the ac supply voltage reversal, a process called *line commutation* or *natural commutation*.

Converter circuits employing only diodes are termed *uncontrolled* (or *rectifiers*) while the incorporation of only thyristors results in a (fully) *controlled converter*. The functional difference is that the diode conducts when forward-biased whereas the turn-on of the forward-biased thyristor can be controlled from its gate. An uncontrolled converter provides a fixed output voltage for a given ac supply and load.

Thyristor converters allow an adjustable output voltage by controlling the phase angle at which the forward biased thyristors are turned on. With diodes, converters can only transfer power from the ac source to the dc load, termed rectification and can therefore be described as *unidirectional converters*. Although rectifiers provide a dc output, they differ in characteristics such as output ripple and mean voltage as well as efficiency and ac supply current harmonics.

An important rectifier characteristic is that of pulse number, which is defined as the repetition rate in the direct output voltage during one complete cycle of the input ac supply.

A useful way to judge the quality of the required dc output, is by the contribution of its superimposed ac harmonics. The harmonic or ripple factor RF is defined by

$$RF_v = \frac{V_{ac}}{V_{dc}} = \sqrt{\frac{V_{rms}^2 - V_{dc}^2}{V_{dc}^2}} = \sqrt{\frac{V_{rms}^2}{V_{dc}^2} - 1} = \sqrt{FF^2 - 1} = \sqrt{\frac{1}{\eta_{eff}} - 1}$$

where FF is termed the form factor. RF_v is a measure of the voltage harmonics in the output voltage while if currents are used in the equation, RF_i gives a measure of the current harmonics in the output current. Both FF and RF are applicable to the input and output, and are defined in section 13.7.

The general analysis in this chapter is concerned with single and three phase ac rectifier supplies feeding inductive and resistive dc loads. Purely resistive load equations generally can be derived by setting inductance L to zero in the L - R load equations. Just as purely inductive load equations generally can be derived by setting resistance R to zero in the same L - R load equations.

13.1 Single-phase uncontrolled converter circuits – ac rectifiers

13.1.1 Half-wave circuit with a resistive load, R

The simplest meaningful single-phase half-wave load to analyse is the resistive load. The ac supply V is impressed across the load every second ac cycle half period, when load current flows.

The load voltage and current shown in figure 13.1a are defined by

$$v_o(\omega t) = i_o R = \begin{cases} \sqrt{2} V \sin \omega t & 0 \leq \omega t \leq \pi \\ 0 & \pi \leq \omega t \leq 2\pi \end{cases} \quad (13.1)$$

The circuit voltage and current equations can be found by substituting $L = 0$, $\beta = \pi$ and $\phi = 0$ in the generalised equations (13.18) to (13.20) in section 13.1.3. The average dc output current I_o and voltage V_o are given by

$$V_o = I_o R = \frac{1}{2\pi} \int_0^\pi \sqrt{2} V \sin \omega t \, d\omega t = \frac{\sqrt{2}}{\pi} V = 0.45V \quad (13.2)$$

The rms voltage across the load $V_{o\,rms}$, and rms load current $I_{o\,rms}$, are

$$V_{o\,rms} = \left[\frac{1}{2\pi} \int_0^\pi 2V^2 \sin^2 \omega t \, d\omega t \right]^{1/2} = I_{o\,rms} R = \frac{1}{\sqrt{2}} V \tag{13.3}$$

and the power dissipated in the load, specifically the load resistor, is

$$P_o = I_{o\,rms}^2 R = \frac{1}{2} \frac{V^2}{R} \tag{13.4}$$

The ac current in the load is

$$I_{ac} = \sqrt{I_{o\,rms}^2 - I_o^2} = \frac{V}{R} \left[\frac{1}{2} - \frac{2}{\pi^2} \right]^{1/2} \tag{13.5}$$

The load voltage harmonics are

$$v_o(\omega t) = \frac{\sqrt{2}V}{\pi} + \frac{\sqrt{2}V}{2} \sin \omega t - \frac{2\sqrt{2}V}{\pi} \left[\frac{1}{1 \times 3} \cos 2\omega t + \frac{1}{3 \times 5} \cos 4\omega t + \dots + \frac{1}{n^2 - 1} \cos n\omega t \dots \right] \tag{13.6}$$

for $n=2, 4, 6, \dots$

For a resistive load, the load voltage and current ripple factors are both $\sqrt{(1/2\pi)^2 - 1}$. $FF = 1/2\pi$. $PF = 0.707$
 The poor output voltage FF can be improved with a capacitor across the output load resistor. $\eta = 0.405$.

13.1.2 Half-wave circuit with a resistive and back emf R-E load

With an opposing emf E in series with the resistive load, the load current and voltage waveforms are as shown in figure 13.1b. Load current commences when the source voltage exceeds the load back emf at

$$\omega t = \alpha = \sin^{-1} \frac{E}{\sqrt{2}V} \tag{13.7}$$

and ceases when the source voltage falls to the load back emf level at

$$\omega t = \pi - \alpha = \pi - \sin^{-1} \frac{E}{\sqrt{2}V} \tag{13.8}$$

The diode conducts for a period $\theta = \pi - 2\alpha$, during which energy is delivered to both the load resistor R and load back emf E .

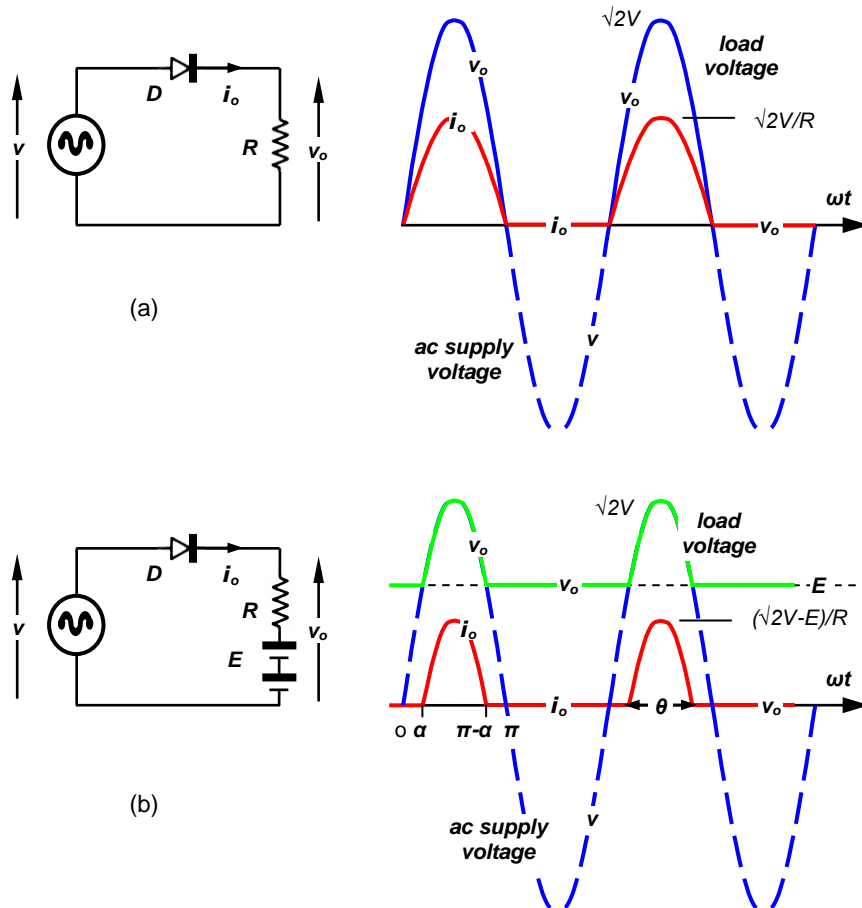

Figure 13.1. Single-phase half-wave rectifiers: (a) purely resistive load, R and (b) resistive load R with back emf, E .

The load average and rms voltages are

$$\begin{aligned} V_o &= \left(\frac{1}{2} + \frac{\alpha}{\pi} \right) E + \frac{1}{2\pi} \int_{\alpha}^{\pi-\alpha} \sqrt{2} V \sin \omega t \, d\omega t \\ &= \left(\frac{1}{2} + \frac{\alpha}{\pi} \right) E + \frac{1}{\pi} \sqrt{2} V \cos \alpha \end{aligned} \quad (13.9)$$

$$V_{o\,rms} = \left[E^2 \left(\frac{1}{2} + \frac{\alpha}{\pi} \right) + V^2 \left(\frac{1}{2} - \frac{\alpha}{\pi} + \frac{1}{2\pi} \sin 2\alpha \right) \right]^{1/2} \quad (13.10)$$

The load average and rms currents are

$$I_o = \frac{1}{R} \left[\frac{\sqrt{2} V}{\pi} \cos \alpha - E \left(\frac{1}{2} - \frac{\alpha}{\pi} \right) \right] = \frac{1}{R} \left[\frac{\sqrt{2} V}{\pi} \sin \frac{1}{2} \theta - E \frac{\theta}{2\pi} \right] \quad (13.11)$$

$$I_{o\,rms} = \frac{1}{R} \left[\frac{V^2}{2\pi} \sin \theta - \frac{2\sqrt{2}}{\pi} V E \sin \frac{1}{2} \theta + (V^2 + E^2) \frac{\theta}{2\pi} \right]^{1/2} \quad (13.12)$$

The total power delivered to the R - E load is

$$P_o = P_R + P_E = I_{o\,rms}^2 R + E I_o \quad (13.13)$$

Example 13.1: Half-wave rectifier with resistive and back emf load

A dc motor has series armature resistance of 10Ω and is fed via a half-wave rectifier, from the single-phase 230V 50Hz ac mains. Calculate

- i. rectifier diode peak current
- ii. motor average starting current

If at full speed, the motor back emf is 100V dc, calculate

- iii. average and rms motor voltages and currents
- iv. motor electrical losses
- v. power converted to rotational energy
- vi. supply power factor and motor efficiency
- vii. diode approximate loss if modelled by $v_D = 0.8 + 0.025 \times i_D$.

Solution

Worst case conditions are at standstill when the motor back emf is zero ($E = k\Phi\omega$) and the circuit and waveforms in figure 13.1a are applicable.

- i. The peak supply and peak load voltage is $\sqrt{2} \times V = \sqrt{2} \times 230 = 325.3V$.
The peak diode and load current is

$$\hat{i}_D = \hat{i}_o = \frac{\hat{V}_o}{R} = \frac{325.3V}{10\Omega} = 32.5A$$

- ii. The motor average current, at starting, is given by equation (13.2)

$$V_o = I_o R = 0.45 \times 230V = 103.5V$$

$$I_o = \frac{V_o}{R} = \frac{103.5V}{10\Omega} = 10.35A$$

With a 100V back emf, the circuit and waveforms in figure 13.1b are applicable.

The current starts conducting when

$$\omega t = \alpha = \sin^{-1} \frac{E}{\sqrt{2} V} = \sin^{-1} \frac{100V}{\sqrt{2} \times 230V} = 17.9^\circ$$

The current conducts for a period $\theta = \pi - 2\alpha = 180^\circ - 2 \times 17.9^\circ = 144.2^\circ$, ceasing at $\omega t = \pi - \alpha = 162.1^\circ$.

- iii. The average and rms load currents and voltages are given by equations (13.9) to (13.12).

$$\begin{aligned} V_o &= \left(\frac{1}{2} + \frac{\alpha}{\pi} \right) E + \frac{1}{\pi} \sqrt{2} V \cos \alpha \\ &= \left(\frac{1}{2} + \frac{17.9^\circ}{180^\circ} \right) \times 100V + \frac{1}{\pi} \sqrt{2} \times 230V \times \cos 17.9^\circ = 158.5V \end{aligned}$$

$$\begin{aligned}
 I_o &= \frac{1}{R} \left[\frac{\sqrt{2}V}{\pi} \sin \frac{1}{2}\theta - E \frac{\theta}{2\pi} \right] \\
 &= \frac{1}{10\Omega} \left[\frac{\sqrt{2} \times 230\text{V}}{\pi} \sin \frac{1}{2} \times 144.2^\circ - 100\text{V} \times \frac{144.2^\circ}{360^\circ} \right] = 5.85\text{A} \\
 V_{o\text{rms}} &= \left[E^2 \left(\frac{1}{2} + \frac{\alpha}{\pi} \right) + V^2 \left(\frac{1}{2} - \frac{\alpha}{\pi} + \frac{1}{2\pi} \sin 2\alpha \right)^2 \right]^{1/2} \\
 &= \left[100^2 \left(\frac{1}{2} + \frac{17.9^\circ}{180^\circ} \right) + 230^2 \left(\frac{1}{2} - \frac{17.9^\circ}{180^\circ} + \frac{1}{2\pi} \sin 2 \times 17.9^\circ \right)^2 \right]^{1/2} = 179.2\text{V} \\
 I_{o\text{rms}} &= \frac{1}{R} \left[\frac{V^2}{2\pi} \sin \theta - \frac{2\sqrt{2}}{\pi} V E \sin \frac{1}{2}\theta + (V^2 + E^2) \frac{\theta}{2\pi} \right]^{1/2} \\
 &= \frac{1}{10\Omega} \left[\frac{230^2}{2\pi} \sin 144.2^\circ - \frac{2\sqrt{2}}{\pi} \times 230\text{V} \times 100\text{V} \times \sin \frac{1}{2} \times 144.2^\circ + (230^2 + 100^2) \frac{144.2^\circ}{360^\circ} \right]^{1/2} \\
 &= 10.2\text{A}
 \end{aligned}$$

iv. The motor loss is the loss in the 10Ω resistor in the dc motor equivalent circuit

$$P_R = I_{o\text{rms}}^2 R = 10.2^2 \times 10\Omega = 1041.5\text{W}$$

v. The back emf represents the source of electrical energy converted to mechanical energy

$$P_E = E \times I_o = 100\text{V} \times 5.85\text{A} = 585\text{W}$$

vi. The supply power factor is defined as the ratio of the supply power delivered, P , to apparent supply power, S

$$pf = \frac{P}{S} = \frac{P_R + P_E}{V \times I_{o\text{rms}}} = \frac{1041.5\text{W} + 585\text{W}}{230\text{V} \times 10.2\text{A}} = 0.69$$

The motor efficiency is

$$\eta = \frac{P_E}{P_R + P_E} = \frac{585\text{W}}{1041.5\text{W} + 585\text{W}} \times 100 = 40.0\%$$

vii. By assuming the diode voltage drop is insignificant in magnitude compared to the 230V ac supply, then the currents and voltages previously calculated involve minimal error. The rectifying diode power loss is

$$\begin{aligned}
 P_D &= 0.8 \times I_o + 0.025\Omega \times I_{o\text{rms}}^2 \\
 &= 0.8 \times 5.85\text{A} + 0.025\Omega \times 10.2^2 = 7.3\text{W}
 \end{aligned}$$



13.1.3 Single-phase half-wave rectifier circuit with an R-L load

A single-phase half-wave diode rectifying circuit with an R-L load is shown in figure 13.2a, while various circuit electrical waveforms are shown in figure 13.2b. Load current commences when the supply voltage goes positive at $\omega t = 0$. It will be seen that load current flows not only during the positive half of the ac supply voltage, $0 \leq \omega t \leq \pi$, but also during a portion of the negative supply voltage, $\pi \leq \omega t \leq \beta$. The load inductor stored energy maintains the load current and the inductor's terminal voltage reverses and is able to overcome the negative supply and keep the diode forward-biased and conducting. This current continues until all the inductor energy, $\frac{1}{2}L\dot{i}^2$, is released ($i = 0$) at the *current extinction angle* (or *cut-off angle*), $\omega t = \beta$.

During diode conduction the circuit is defined by the Kirchhoff voltage equation

$$v_R + v_L = L \frac{di}{dt} + Ri = v = \sqrt{2} V \sin \omega t \quad (\text{V}) \quad (13.14)$$

where V is the rms ac supply voltage. Solving equation (13.14) yields the load (and diode) current

$$i(\omega t) = \frac{\sqrt{2}V}{Z} \left\{ \sin(\omega t - \phi) + \sin \phi e^{-\omega t / \tan \phi} \right\} \quad (\text{A}) \quad (13.15)$$

$$0 \leq \omega t \leq \beta \geq \pi \quad (\text{rad})$$

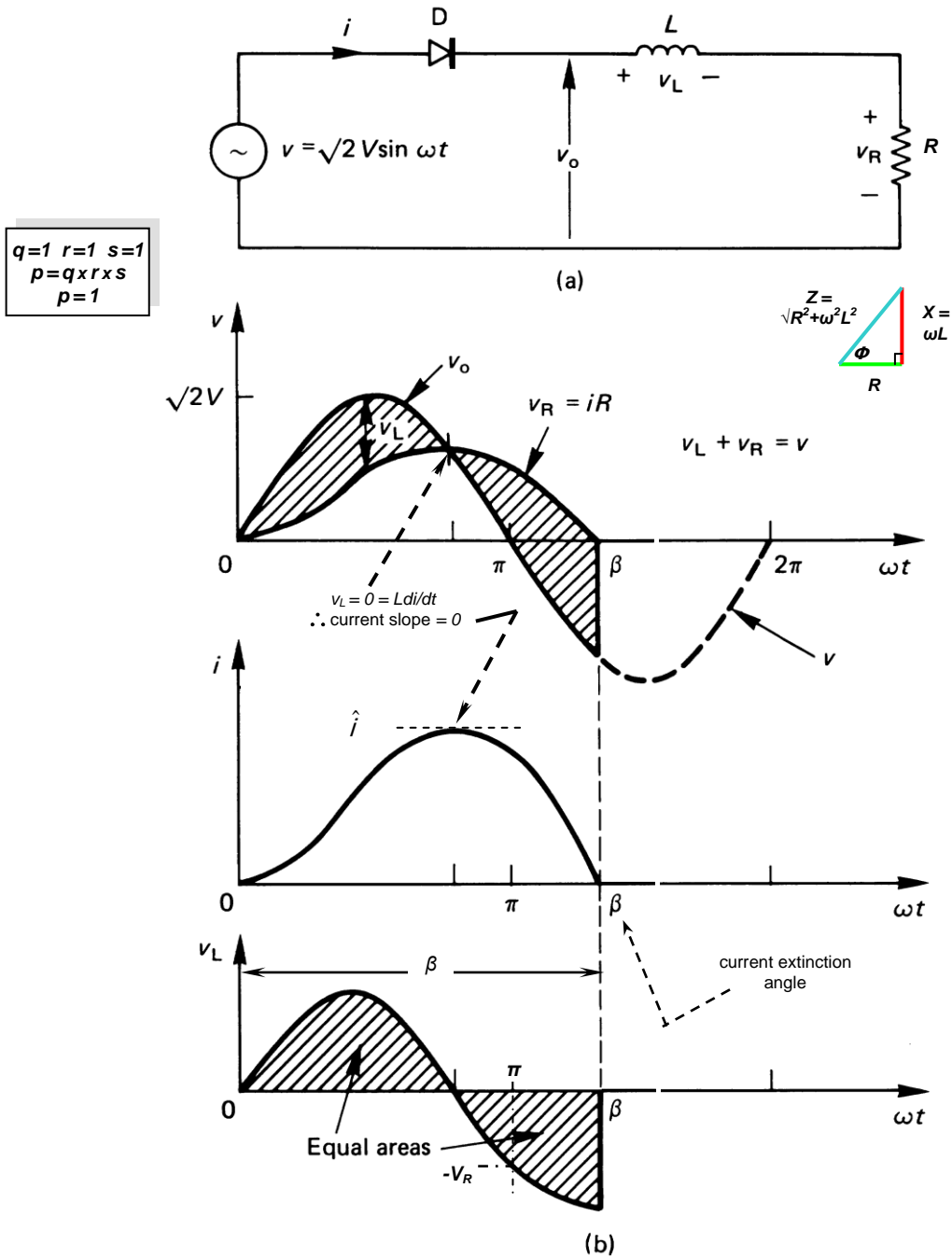

Figure 13.2. Half-wave rectifier with an R-L load:
 (a) circuit diagram and (b) waveforms, illustrating the equal area and zero current slope criteria.

where $Z = \sqrt{R^2 + \omega^2 L^2}$ (ohms)
 $\tan \phi = \omega L / R = Q$ and $R = Z \cos \phi$

$$i(\omega t) = 0 \tag{A}$$

$$\beta \leq \omega t \leq 2\pi \tag{rad}$$

(13.16)

The current extinction angle β is determined solely by the load impedance Z and can be solved from equation (13.15) when the current, $i = 0$ with $\omega t = \beta$, such that $\beta > \pi$, that is

$$\sin(\beta - \phi) + \sin \phi e^{-\beta / \tan \phi} = 0 \tag{13.17}$$

This is a transcendental equation which can be solved by iterative techniques. Figure 13.3a can be used to determine the extinction angle β , given any load impedance (power factor) angle $\phi = \tan^{-1} \omega L / R$.

The mean value of the rectified current, the output current, \bar{I}_o , is given by integration of equation (13.15)

$$\bar{I}_o = \frac{1}{2\pi} \int_0^\beta i(\omega t) d\omega t \tag{A}$$

$$\bar{I}_o = \frac{\sqrt{2}V}{2\pi R} (1 - \cos \beta) \tag{A}$$

(13.18)

while the mean output voltage V_o is given by

$$V_o = \frac{1}{2\pi} \int_0^\beta \sqrt{2} V \sin \omega t \, d\omega t = \bar{I}_o R = \frac{\sqrt{2}V}{2\pi} (1 - \cos \beta) \quad (V) \quad (13.19)$$

Since the mean voltage across the load inductance is zero, $V_o = \bar{I}_o R$ (see the equal area criterion to follow). Figure 13.3b shows the normalised output voltage V_o / V as a function of $\omega L / R$.

The rms output (load) voltage and current are given by

$$V_{rms} = \left[\frac{1}{2\pi} \int_0^\beta (\sqrt{2}V)^2 \sin^2 \omega t \, d\omega t \right]^{1/2} = V \left[\frac{1}{2\pi} \left\{ \beta - \frac{1}{2} \sin 2\beta \right\} \right]^{1/2} \quad (13.20)$$

$$i_{rms} = \frac{V \cos \phi}{R} \left[\frac{1}{2\pi} \left\{ \beta - \frac{\sin \beta \cos(\beta + \phi)}{\cos \phi} \right\} \right]^{1/2} = \frac{V}{Z} \left[\frac{1}{2\pi} \left\{ \beta - \frac{\sin \beta \cos(\beta + \phi)}{\cos \phi} \right\} \right]^{1/2}$$

From equations (13.19) and (13.20) the harmonic content in the output voltage is indicated by the voltage form factor.

$$FF_v = \frac{V_{rms}}{V_o} = \frac{\left[\pi \left\{ \beta - \frac{1}{2} \sin 2\beta \right\} \right]^{1/2}}{1 - \cos \beta} \quad (13.21)$$

For a resistive load, when $\beta = \pi$, the form factor reduces to a value of 1.57. The ripple factor is therefore $\sqrt{FF_v^2 - 1} = 1.21$. For a purely resistive load the voltage and current form factors are equal.

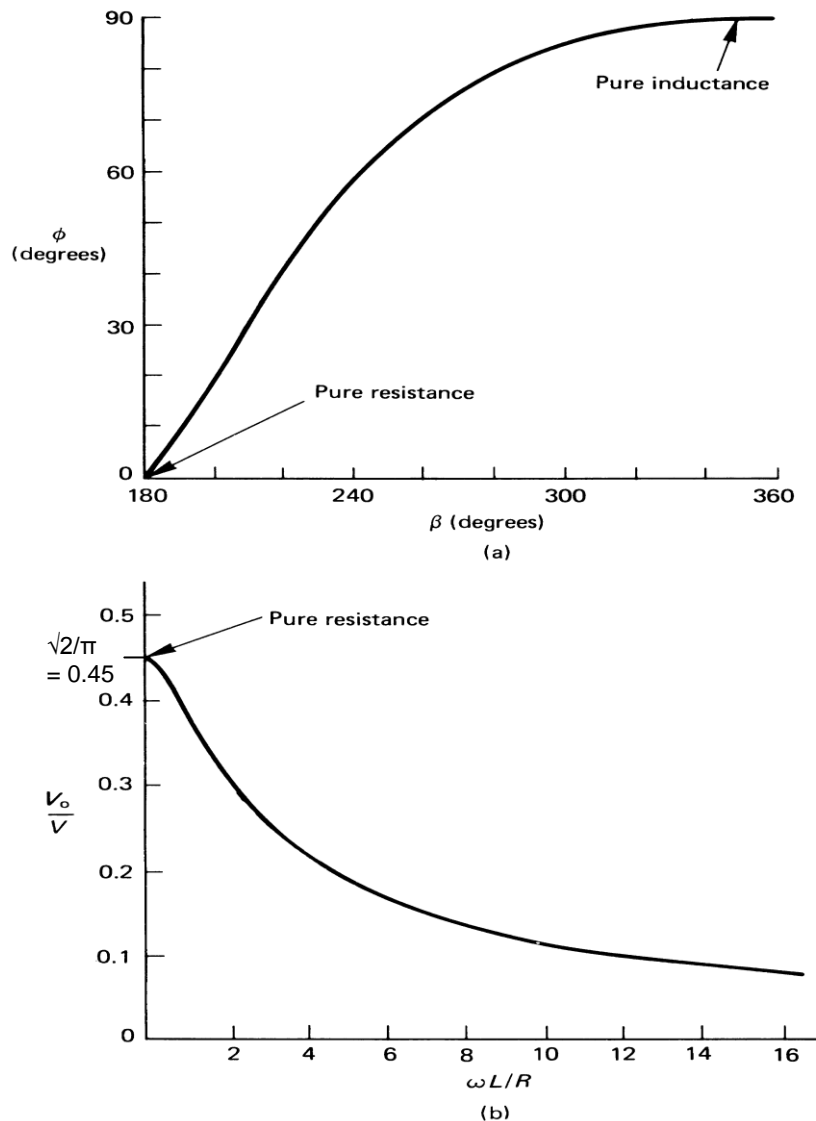

Figure 13.3. Single-phase half-wave converter characteristics: (a) load impedance angle ϕ versus current extinction angle β and (b) variation in normalised mean output voltage V_o / V versus $\omega L / R$.

The power delivered to the load, which is the power delivered to the load resistance R , is

$$P_L = I_{rms}^2 R \quad (13.22)$$

The supply power factor, using the rms current in equation (13.20), is

$$pf = \frac{\text{power, } P_L}{\text{apparent power}} \quad (13.23)$$

$$= \frac{I_{rms}^2 R}{I_{rms} V} = \frac{I_{rms} R}{V} = \frac{V_{R,rms}}{V} = \left[\frac{1}{2\pi} \left\{ \beta - \frac{\sin \beta \cos(\beta + \phi)}{\cos \phi} \right\} \right]^{1/2} \cos \phi = \mu \times \cos \phi$$

The characteristics for an R - L - E load can be determined by using $\alpha = 0$ in the case of the half-wave controlled converter in section 14.2.1iii.

For a purely inductive load, L , $\beta = 2\pi$ is substituted into the appropriate equations. The average output voltage tends to zero and the current is given by

$$i(\omega t) = \frac{\sqrt{2}V}{\omega L} \{1 - \cos \omega t\} \quad (A)$$

which has a mean current value of $\sqrt{2} V/\omega L$.

13.1.3i – Inductor equal voltage area criterion

The average output voltage V_o , given by equation (13.19), is based on the fact that the average voltage across the load inductance, in steady state, is zero. The inductor voltage is given by

$$v_L = L di / dt \quad (V)$$

which for the circuit in figure 13.2a can be expressed as

$$\int_0^{\beta/\omega} v_L(t) dt = \int_{i_o}^{i_\beta} L di = L(i_\beta - i_o) \quad (13.24)$$

If the load current is in steady state then $i_\beta = i_o$, which is zero here, and in general

$$\int v_L dt = 0 \quad (Vs) \quad (13.25)$$

The inductor voltage waveform for the circuit in figure 13.2a is shown in the last plot in figure 13.2b. The inductor equal voltage area criterion implies that the shaded positive area must equal the shaded negative area, in order to satisfy equation (13.25). The net inductor energy at the end of the cycle is zero (specifically, unchanged since $i_o = i_\beta$), that is, the energy into the inductor equals the energy transferred from the inductor. This area aspect is a useful aid in predicting and drawing the load current waveform.

It is useful to superimpose the supply voltage v , the load voltage v_o , and the resistor voltage v_R waveforms on the same time axis, ωt . The load resistor voltage, $v_R = Ri$, is directly related to the load current, i . The inductor voltage v_L will be the difference between the load voltage and the resistor voltage, and this bounded net area must be zero. Thus the average output voltage is $V_o = I_o R$. The equal voltage areas associated with the load inductance are shown shaded in two plots in figure 13.2b.

13.1.3ii - Load current zero slope criterion

The load inductance voltage polarity changes from positive to negative as energy initially transferred into the inductor, is released. The stored energy in the inductor allows current to continue to flow after the input ac voltage has reversed. At the instant when the inductor voltage reverses, its terminal voltage is zero, and

$$v_L = L di / dt = 0 \quad (13.26)$$

$$\text{that is } di / dt = 0$$

The current slope changes from positive to negative, whence the voltage across the load resistance ceases to increase and starts to decrease, as shown in figure 13.2b. That is, the Ri waveform crosses the supply voltage waveform with zero slope, whence when the inductor voltage is zero, the current begins to decrease. The fact that the resistor voltage slope is zero when $v_L = 0$, aids prediction and sketching of the various circuit waveforms in figure 13.2b, and subsequent waveforms in this chapter.

13.1.4 Single-phase half-wave rectifier circuit with an R - L load and a back emf

If α is the angle at which conduction begins and γ is the diode conduction angle, greater than $\pi - 2\alpha$, then for a back emf E

$$\sin \alpha = \frac{E}{\sqrt{2}V} = m$$

The current is given by

$$i = \frac{\sqrt{2}V}{Z} \left[\sin(\omega t - \phi) - \left\{ \frac{m}{\cos \phi} - B e^{-Rt/L} \right\} \right] \quad \alpha < \omega t < \alpha + \gamma$$

where

$$\cos \phi = \frac{R}{Z} = \frac{R}{\sqrt{R^2 + \omega^2 L^2}} \quad B = \left[\frac{m}{\cos \phi} - \sin(\alpha - \phi) \right] e^{\alpha R/\omega L} \quad \omega t = \alpha$$

Substituting $i = 0$ at $\omega t = \alpha + \gamma$ gives

$$e^{-\gamma/\omega t} = \frac{m - \cos \phi \sin(\alpha + \gamma - \phi)}{m - \cos \phi \sin(\alpha - \phi)}$$

An iterative solution in terms of m, ϕ, γ is shown in figure 13.4

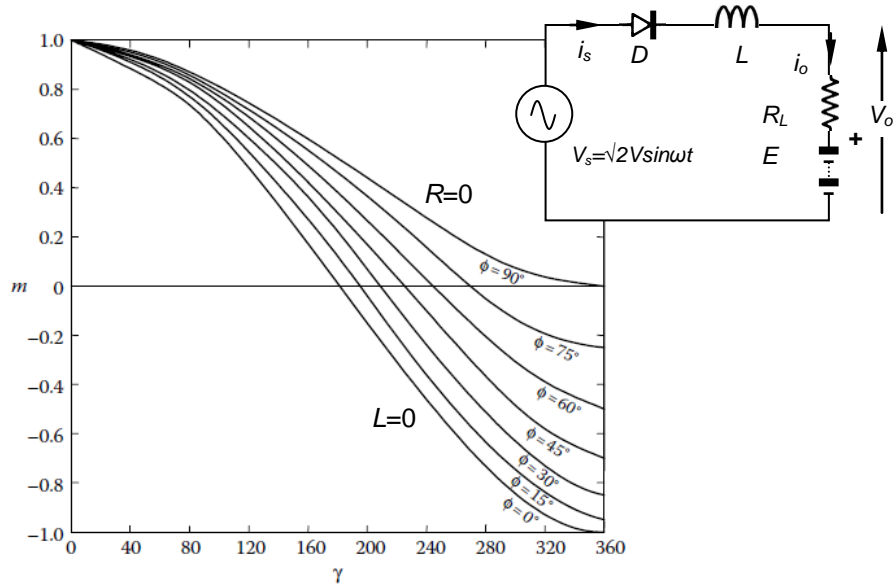

Figure 13.4. Single-phase half-wave rectifier: (a) circuit with a inductive R-L load and back emf E and (b) design curves.

$L=0$ gives $\cos \phi = 1$, the curve $\phi = 0^\circ$ in figure 13.4 and equation 13.11.

$$I_o = \frac{\sqrt{2}V}{\pi R} [\cos \alpha - m(\frac{1}{2}\pi - \alpha)] = \frac{\sqrt{2}V}{\pi R} [\sqrt{1 - m^2} - m \cos^{-1} m]$$

13.1.5 Half-wave rectifier circuit with an R load and capacitor filter

The output voltage ripple factor of a half-wave rectifier with a resistive load can be improved by adding decoupling capacitance across the load output, as shown in figure 13.5.

In the period $\alpha \leq \omega t \leq \beta$

$$v_o(t) = \sqrt{2}V_s \sin \omega t$$

and

$$i_s = i_c + i_o = C \frac{dv_o}{dt} + \frac{v_o}{R_L}$$

Solving for the source current i_s

$$\begin{aligned} i_s(t) &= \frac{\sqrt{2}V_s}{R_L} [\omega R_L C \cos \omega t + \sin \omega t] \\ &= \frac{\sqrt{2}V_s}{R_L} \sqrt{1 + (\omega R_L C)^2} \cos(\omega t - \theta) \end{aligned} \quad (13.27)$$

where $\theta = \tan^{-1} \frac{1}{\omega R_L C}$

Since $i_s = 0$ when $\omega t = \beta$, $\beta - \theta = \frac{1}{2}\pi$. That is

$$\beta = \frac{1}{2}\pi + \theta = \frac{1}{2}\pi + \tan^{-1} \frac{1}{\omega R_L C}$$

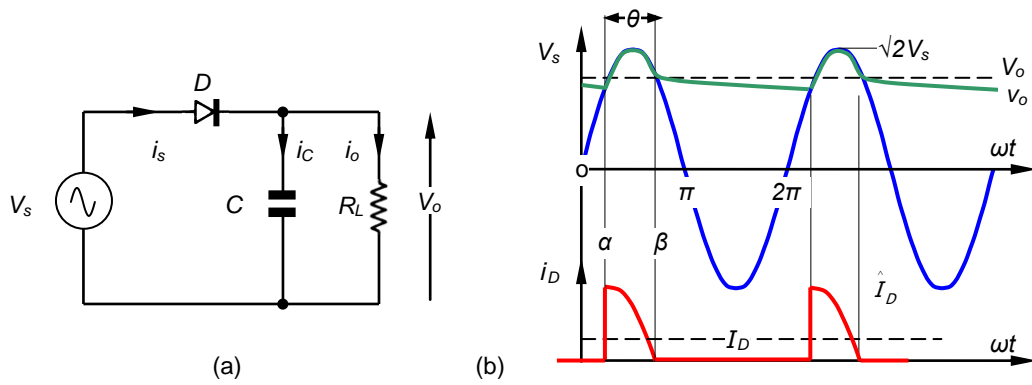

Figure 13.5. Single-phase half-wave rectifier: (a) circuit with a capacitively filtered resistive load and (b) waveforms.

For the period $\beta \leq \omega t \leq 2\pi + \alpha$

$$i_s = 0$$

and

$$C \frac{dv_o}{dt} + \frac{v_o}{R_L} = 0 \quad \text{where } v_o(\omega t = \beta) = \sqrt{2}V_s \cos \theta$$

Therefore

$$v_o(t) = \sqrt{2}V_s e^{-(\omega t - \beta)\tan \theta} \cos \theta \tag{13.28}$$

Since $v_o = \sqrt{2}V_s \sin \alpha$ when $\omega t = 2\pi + \alpha$

$$\sin \alpha = e^{-\alpha \tan \theta} e^{-(\frac{3}{2}\pi - \theta)\tan \theta} \cos \theta$$

where α can be solved iteratively.

The peak to peak ripple voltage is $2V_s(1 - \sin \alpha)$, which decreases as C increases for which $\alpha \rightarrow \frac{1}{2}\pi$. The peak inverse voltage rating of the diode is approximately $2\sqrt{2}V_s$. Capacitor peak current is $\omega C \sqrt{2}V_s \sin \alpha$. The full-wave rectified case is considered in section 13.1.9iv, where the period boundary $\omega t = \pi + \alpha$ is used.

Example 13.2: Half-wave rectifier with source resistance

In the dc supply half-wave rectifier circuit of figure 13.6, the source voltage is $230\sqrt{2} \sin(2\pi 50t)$ V with an internal resistance $R_i = 1$ Ohm, $R_L = 10$ Ohms, and the filter capacitor C is very large. Calculate

- i. the mean value of the load voltage, V_o
- ii. the diode average and peak currents, I_D, \hat{I}_D
- iii. the capacitor peak charging and discharging currents
- iv. the diode reverse blocking voltage, V_{DR}

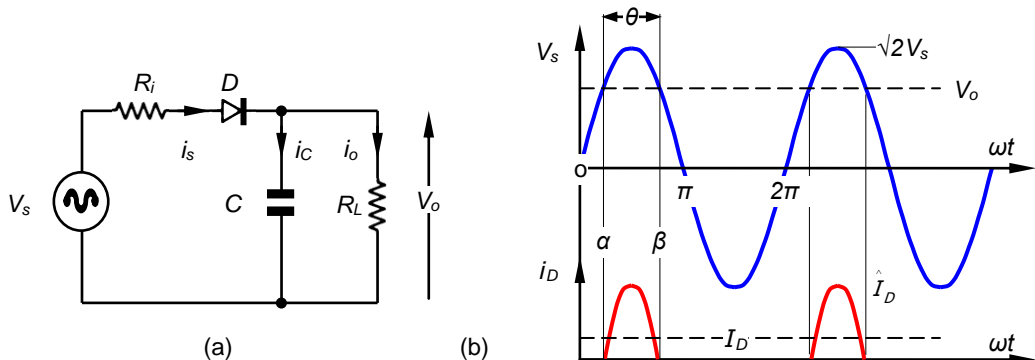

Figure 13.6. Single-phase half-wave rectifier: (a) circuit with a resistive load and (b) waveforms.

Solution

- i. Because the load filter capacitor is large, it is assumed that the dc output voltage is ripple free and constant. The capacitor provides the load current when the ac supply level is less than the dc output. The load current and peak diode (hence supply) current are therefore

$$I_o = \frac{V_o}{R_L} \quad \hat{I}_D = \frac{\sqrt{2}V_s - V_o}{R_f}$$

The ac supply provides current, through the rectifying diode, during the period

$$i_s = \frac{1}{R_f} (\sqrt{2}V_s \sin \omega t - V_o) \quad \alpha \leq \omega t \leq \beta$$

If the capacitor voltage is to be maintained constant, the charge into the capacitor must equal the charge delivered by the capacitor when the rectifying diode is not conducting, that is

$$\int_{\alpha}^{\beta} (i_s - i_o) d\omega t = \int_{\beta}^{\alpha+2\pi} i_o d\omega t$$

Also

$$V_o = \sqrt{2}V_s \sin \alpha$$

$$\alpha = \frac{\pi - \theta}{2} \quad \beta = \frac{\pi + \theta}{2}$$

Manipulation yields

$$\tan \frac{1}{2}\theta - \frac{1}{2}\theta = \pi \frac{R_f}{R_L} = \pi \frac{1\Omega}{10\Omega} = 0.1\pi$$

An iterative solution yields $\theta = 99.6^\circ$, that is, the diode conducts for a period of 5.53ms (10ms \times 99.6°/180°), every cycle of the ac supply, 20ms. The capacitor, hence output voltage, is

$$V_o = \sqrt{2}V_s \sin \alpha = \sqrt{2}V_s \sin \frac{\pi - \theta}{2}$$

$$= \sqrt{2} \times 230V \times \sin \frac{180^\circ - 99.6^\circ}{2} = 209.95V$$

- ii. The average diode current is given by

$$\bar{I}_D = \frac{1}{2\pi} \int_{\alpha}^{\beta} \frac{1}{R_f} (\sqrt{2}V_s \sin \omega t - V_o) d\omega t = \frac{1}{2\pi R_f} \left(\sqrt{2}V_s \times 2 \times \cos \frac{\pi - \theta}{2} - V_o \times \theta \right)$$

$$= \frac{1}{2\pi \times 1\Omega} \left(\sqrt{2} \times 230V \times 2 \times \cos \frac{180^\circ - 99.6^\circ}{2} - 209.95V \times \pi \times \frac{99.6^\circ}{180^\circ} \right) = 21.0A$$

Alternatively, as would be expected, the average diode current is the average load current:

$$\bar{I}_D = I_o = \frac{V_o}{R_L} = \frac{209.95V}{10\Omega} = 21.0A$$

The peak diode current is

$$\hat{I}_D = \frac{\sqrt{2}V_s - V_o}{R_f} = \frac{\sqrt{2} \times 230V - 210V}{1\Omega} = 115.3A$$

- iii. The capacitor peak charging current is the difference between the peak diode current and the load current, viz., 115A - 21A = 94A, while the peak discharging current is the average load current of 21A.
- iv. The diode reverse voltage is the difference between the instantaneous supply voltage and the output voltage 210V. This is a maximum at the negative peak of the ac supply, when the diode voltage is $\sqrt{2} \times 230V + 210V = 535.3V$. During any period when the load is disrupted, the output capacitor can charge up to $\sqrt{2} \times 230V$, hence the diode can experience, worst case, $2 \times \sqrt{2} \times 230V = 650.5V$.

**13.1.6 Half-wave circuit with an R-L load and freewheel diode**

The circuit in figure 13.2a, which has an R-L load, is characterised by discontinuous current ($i = 0$) and high ripple current. Continuous load current can result when a diode D_f is added across the load as shown in figure 13.7a. This freewheel diode prevents the voltage across the load from reversing during the negative half-cycle of the ac supply voltage. The inductor energy is not returned to the ac supply, rather is retained in the load circuit. The stored energy in the inductor cannot reduce to zero

instantaneously, so the current is forced to find an alternative path whilst decreasing towards zero. When the rectifier diode D_1 ceases to conduct at zero volts it blocks, and diode D_f provides an alternative load current freewheeling path, as indicated by the waveforms in figure 13.7b.

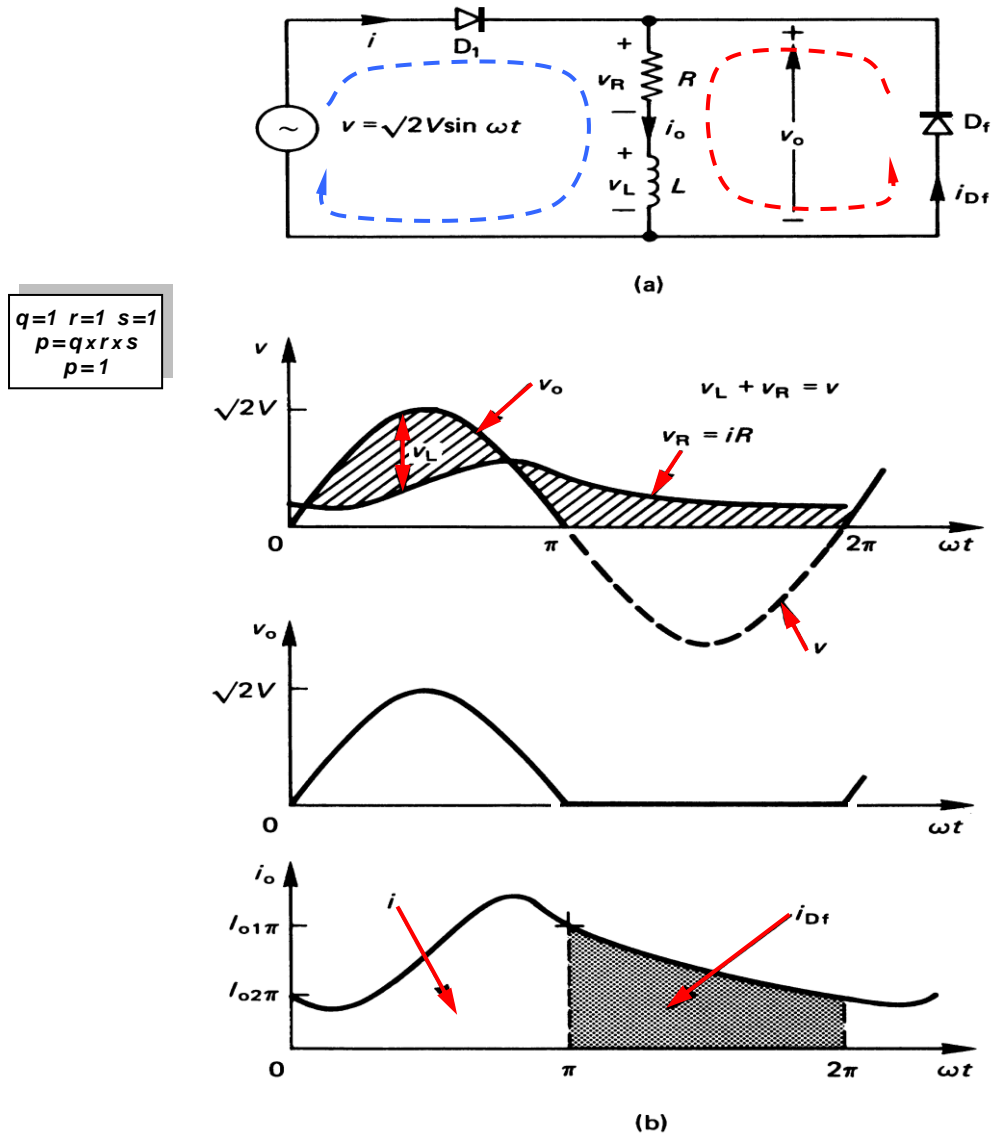

Figure 13.7. Half-wave rectifier with a load freewheel diode and an R-L load: (a) circuit diagram and parameters and (b) circuit waveforms.

The output voltage is the positive half of the sinusoidal input voltage. The mean output voltage (thence mean output current) is

$$V_o = \bar{I}_o R = \frac{1}{2\pi} \int_0^\pi \sqrt{2}V \sin \omega t \, d\omega t \tag{13.29}$$

$$V_o = \frac{\sqrt{2}V}{\pi} = 0.45 \times V = \bar{I}_o R \tag{V}$$

The rms value of the load circuit voltage v_o is given by

$$V_{rms} = \sqrt{\frac{1}{2\pi} \int_0^\pi (\sqrt{2}V \sin \omega t)^2 \, d\omega t} \tag{13.30}$$

$$= \frac{V}{\sqrt{2}} = 0.71 \times V \tag{V}$$

The output ripple (ac) voltage is defined as

$$V_{Ri} \triangleq \sqrt{V_{rms}^2 - V_o^2} \tag{13.31}$$

$$= \sqrt{\left(\frac{\sqrt{2}V}{2}\right)^2 - \left(\frac{\sqrt{2}V}{\pi}\right)^2} = V \sqrt{1/2 - 2/\pi^2} = 0.545 \times V$$

hence the load voltage form and ripple factors are defined as

$$FF_v = V_{rms} / V_o = 1/\sqrt{2} = 1.57$$

$$RF_v \triangleq V_{Ri} / V_o = \sqrt{\left(\frac{V_{rms}}{V_o}\right)^2 - 1} = \sqrt{FF_v^2 - 1} = \sqrt{1/2 - 1} = 1.211 \quad (13.32)$$

After a large number of ac supply cycles, steady-state load current conditions are established, and from Kirchhoff's voltage law, the load current is defined by

$$L \frac{di}{dt} + Ri = \sqrt{2}V \sin \omega t \quad (A) \quad 0 \leq \omega t \leq \pi \quad (13.33)$$

and when the freewheel diode conducts

$$L \frac{di}{dt} + Ri = 0 \quad (A) \quad \pi \leq \omega t \leq 2\pi \quad (13.34)$$

During the period $0 \leq \omega t \leq \pi$, when the freewheel diode current is given by $i_{Df} = 0$, the supply current, which is the load current, are given by

$$i(\omega t) = i_o(\omega t) = \frac{\sqrt{2}V}{Z} \sin(\omega t - \phi) + (I_{o2\pi} + \frac{\sqrt{2}V}{Z} \sin \phi) e^{-\omega t / \tan \phi} \quad (A) \quad (13.35)$$

$$0 \leq \omega t \leq \pi$$

for

$$I_{o2\pi} = \frac{\sqrt{2}V}{Z} \sin \phi \frac{1 + e^{-\pi / \tan \phi}}{e^{\pi / \tan \phi} - e^{-\pi / \tan \phi}} \quad (A)$$

$$\text{where } Z = \sqrt{R^2 + (\omega L)^2} \quad (\text{ohms})$$

$$\tan \phi = \omega L / R$$

During the period $\pi \leq \omega t \leq 2\pi$, when the supply current $i = 0$, the freewheel diode current and hence load current are given by

$$i_o(\omega t) = i_{Df}(\omega t) = I_{o1\pi} e^{-(\omega t - \pi) / \tan \phi} \quad (A) \quad \pi \leq \omega t \leq 2\pi \quad (13.36)$$

for

$$I_{o1\pi} = I_{o2\pi} e^{\pi / \tan \phi} \quad (A)$$

For discontinuous load current (the freewheel diode current i_{Df} falls to zero before the rectifying diode D_1 recommences conduction), the appropriate integration gives the average diode currents as

$$\bar{I}_{D1} = \frac{V}{\sqrt{2} \pi R} (2 - (1 + e^{-\pi / \tan \phi}) \times \sin^2 \phi)$$

$$\bar{I}_{Df} = \bar{I}_o - \bar{I}_{D1} = \frac{V}{\sqrt{2} \pi R} (1 + e^{-\pi / \tan \phi}) \times \sin^2 \phi \quad (13.37)$$

In figure 13.7b it will be seen that although the load current can be continuous, the supply current is discontinuous and therefore has a high harmonic content.

The output voltage Fourier series ($V_o + V_1 + V_{n=2,4,6..}$) is (see equation (13.6))

$$v_o(t) = \frac{\sqrt{2}V}{\pi} + \frac{\sqrt{2}V}{2} \sin \omega t - \frac{\sqrt{2}V}{\pi} \sum_{n=2,4,6}^{\infty} \frac{2}{(n^2 - 1)} \cos n\omega t \quad (13.38)$$

Dividing each harmonic output voltage component by the corresponding load impedance at that frequency gives the harmonic output current, whence rms current. That is

$$I_n = \frac{V_n}{Z_n} = \frac{V_n}{|R + jn\omega L|} = \frac{V_n}{\sqrt{R^2 + (n\omega L)^2}} \quad (13.39)$$

and

$$I_{rms} = \sqrt{I_o^2 + \sum_{n=1,2,4,6..} 1/2 I_n^2} \quad (13.40)$$

Example 13.3: Half-wave rectifier – with load freewheel diode

In the circuit of figure 13.7, the source voltage is $240\sqrt{2} \sin(2\pi 50t)$ V, $R = 10$ ohms, and $L = 50$ mH. Calculate

- the mean and rms values of the load voltage, V_o and V_{rms}
- the mean value of the load current, \bar{I}_o
- the current boundary conditions, namely $I_{o1\pi}$ and $I_{o2\pi}$
- the average freewheel diode current, hence average rectifier diode current
- the rms load current, hence load power and supply rms current
- the supply power factor

If the freewheel diode is removed from across the load, determine

- vii. an expression for the current hence the current extinction angle
- viii. the average load voltage hence average load current
- ix. the rms load voltage and current
- x. the power delivered to the load and supply power factor

From the rms and average output voltages and currents, determine the load form and ripple factors.

Solution

- i. From equation (13.29), the mean output voltage is given by

$$V_o = \sqrt{2}V/\pi = \sqrt{2} \times 240V/\pi = 108V$$

From equation (13.30) the load rms voltage is

$$V_{rms} = V/\sqrt{2} = 240V/\sqrt{2} = 169.7V$$

- ii. The mean output current, equation (13.29), is

$$\bar{I}_o = V_o/R = \sqrt{2}V/\pi R = \sqrt{2} \times 240V/\pi \times 10\Omega = 10.8A$$

- iii. The load impedance is characterised by

$$Z = \sqrt{R^2 + (\omega L)^2} \\ = \sqrt{10^2 + (2\pi \times 50\text{Hz} \times 0.05)^2} = 18.62 \Omega$$

$$\tan \phi = \omega L/R$$

$$= 2\pi \times 50\text{Hz} \times 0.05\text{H}/10\Omega = 1.57 \text{ or } \phi = 57.5^\circ \approx 1\text{rad}$$

From section 13.1.6, equation (13.35)

$$I_{o2\pi} = \frac{\sqrt{2}V}{Z} \sin \phi \frac{1 + e^{-\pi/\tan \phi}}{e^{\pi/\tan \phi} - e^{-\pi/\tan \phi}}$$

$$I_{o2\pi} = \frac{\sqrt{2} \times 240V}{18.62\Omega} \times \sin(\tan^{-1} 1.57) \times \frac{1 + e^{-\pi/1.57}}{e^{\pi/1.57} - e^{-\pi/1.57}} = 3.41A$$

Hence, from equation (13.36)

$$I_{o1\pi} = I_{o2\pi} e^{\pi/\tan \phi} = 3.41 \times e^{\pi/1.57} = 25.22A$$

Since $I_{o2\pi} = 3.41A > 0$, continuous load current flows.

- iv. Integration of the diode current given in equation (13.36) yields the average freewheel diode current.

$$\bar{I}_{Df} = \frac{1}{2\pi} \int_0^\pi i_{Df}(\omega t) d\omega t = \frac{1}{2\pi} \int_0^\pi I_{o1\pi} e^{-\omega t/\tan \phi} d\omega t \\ = \frac{1}{2\pi} \int_0^\pi 25.22A \times e^{-\omega t/1.57\text{rad}} d\omega t = \frac{25.22A}{2\pi} \times 1.57\text{rad} \times \left[1 - e^{-\frac{\pi}{1.57}} \right] = 5.46A$$

The average input current, which is the rectifying diode mean current, is given by

$$\bar{I}_s = \bar{I}_{D1} = \bar{I}_o - \bar{I}_{Df} = 10.8A - 5.46A = 5.34A$$

harmonic n	$V_n = \frac{2\sqrt{2}V}{(n^2 - 1)\pi}$ (V)	$Z_n = \sqrt{R^2 + (n\omega L)^2}$ (Ω)	$I_n = \frac{V_n}{Z_n}$ (A)	$\frac{1}{2}I_n^2$
0	(108.04)*	10.00	10.80	(116.72)
1	(169.71)*	18.62	9.11	41.53
2	72.03	32.97	2.18	2.39
4	14.41	63.62	0.23	0.03
6	6.17	94.78	0.07	0.00
8	3.43	126.06	0.03	0.00
see equation (13.38) for first two terms			$I_o^2 + \sum \frac{1}{2}I_n^2 =$	160.67

- v. The load voltage harmonics given by equation (13.38) can be used to evaluate the load current at the load impedance for that frequency harmonic.

$$v(t) = \frac{\sqrt{2}V}{\pi} + \frac{\sqrt{2}V}{2} \sin \omega t - \sum_{n=2,4,6}^{\infty} \frac{2\sqrt{2}V}{(n^2-1)\pi} \cos(n\omega t)$$

The preceding table shows the calculations for each frequency component.

The rms load current is

$$I_{rms} = \sqrt{I_o^2 + \sum_{n=1,2,4..} \frac{1}{2} I_n^2} = \sqrt{160.7} = 12.68A$$

The power dissipated in the load resistance is therefore

$$P_{10\Omega} = I_{rms}^2 R = 12.68A^2 \times 10\Omega = 1606.7W$$

The freewheel diode rms current is

$$\begin{aligned} I_{Df} &= \sqrt{\frac{1}{2\pi} \int_0^{\pi} (I_{o1\pi} e^{-\omega t / \tan \phi})^2 d\omega t} \\ &= \sqrt{\frac{1}{2\pi} \int_0^{\pi} (25.22A \times e^{-\omega t / 1.57 \text{rad}})^2 d\omega t} = 8.83A \end{aligned}$$

Thus the input (and rectifying diode) rms current is given by

$$\begin{aligned} I_{D1,rms} = I_{s,rms} &= \sqrt{I_{rms}^2 - I_{Df,rms}^2} \\ &= \sqrt{12.68^2 - 8.83^2} = 9.09A \end{aligned}$$

- vi. The input ac supply power factor is

$$pf = \frac{P_{out}}{V_{rms} I_{rms}} = \frac{1606.7W}{240V \times 9.09A} = 0.74$$

- vii. If the freewheel diode D_f is removed, the current is given by equation (13.15), that is

$$\begin{aligned} i(\omega t) &= \frac{\sqrt{2}V}{Z} \{ \sin(\omega t - \phi) + \sin \phi e^{-\omega t / \tan \phi} \} \\ &= \frac{\sqrt{2} \times 240V}{18.62\Omega} \{ \sin(\omega t - 1.0) + 0.841 \times e^{-\omega t / 1.57} \} \\ &= 18.23 \times \{ \sin(\omega t - 1.0) + 0.841 \times e^{-\omega t / 1.57} \} \quad (A) \quad 0 \leq \omega t \leq \beta \quad (\text{rad}) \end{aligned}$$

The current extinction angle β is found by setting $i = 0$ and solving iteratively for β . Figure 13.3a gives an initial estimate of 240° (4.19 rad) when $\phi = 57.5^\circ$ (1 rad). That is

$$0 = \sin(\beta - 1.0) + 0.841 \times e^{-\beta / 1.57}$$

gives $\beta = 4.08$ rad or 233.8° , after iteration.

- viii. The average load voltage from equation (13.19) is

$$V_o = \frac{\sqrt{2}V}{2\pi} (1 - \cos \beta) = \frac{\sqrt{2} \times 240V}{2\pi} (1 - \cos 4.08) = 86.0V$$

The average load current is

$$\bar{I}_o = V_o / R = 86.0V / 10\Omega = 8.60A$$

- ix. The load rms voltage is 169.7V with the freewheel diode and increases without the diode to, as given by equation (13.20)

$$\begin{aligned} V_{rms} &= V \left[\frac{1}{2\pi} \{ \beta - \frac{1}{2} \sin 2\beta \} \right]^{1/2} \\ &= 240V \left[\frac{1}{2\pi} \{ 4.08 - \frac{1}{2} \sin 2 \times 4.08 \} \right]^{1/2} = 181.6V \end{aligned}$$

The rms load current from equation (13.20) is decreased to

$$\begin{aligned} i_{rms} &= \frac{V}{Z} \left[\frac{1}{2\pi} \left\{ \beta - \frac{\sin \beta \cos(\alpha + \beta + \phi)}{\cos \phi} \right\} \right]^{1/2} \\ &= \frac{240V}{18.62\Omega} \times \left[\frac{1}{2\pi} \left\{ 4.08 - \frac{\sin 4.08 \cos(4.08 + 1.57)}{\cos 1.57} \right\} \right]^{1/2} = 9.68A \end{aligned}$$

Removal of the freewheel diode decreases the rms load current from 12.68A to 9.68A.

- x. The load power is reduced without a load freewheel diode, from 1606.7W with a load freewheel diode, to

$$P_{10\Omega} = i_{rms}^2 R = 9.68^2 \times 10\Omega = 937W$$

The supply power factor is also reduced, from 0.74 to

$$pf = \frac{P_{out}}{V_{rms} I_{rms}} = \frac{937W}{240V \times 9.68A} = 0.40$$

Load factor	circuit with freewheel diode		circuit without freewheel diode	
	form factor	ripple factor	form factor	ripple factor
	$FF = \frac{rms}{ave}$	$RF = \sqrt{FF^2 - 1}$	$FF = \frac{rms}{ave}$	$RF = \sqrt{FF^2 - 1}$
Voltage factor	169.7V/108V = 1.57	1.21	181.6V/86V = 2.1	1.86
Current factor	12.68A/10.8A = 1.17	0.615	9.68A/8.60A = 1.12	0.517



13.1.7 Single-phase full-wave bridge rectifier circuit with a resistive load, R

The simplest meaningful single-phase full-wave load to analyse is the resistive load. The supply is impressed across the load every ac cycle half period, when load current flows.

The load voltage and current shown in figure 13.8a are defined by

$$v_o(\omega t) = i_o R = \left| \sqrt{2} V \sin \omega t \right| \quad 0 \leq \omega t \leq 2\pi \quad (13.41)$$

The average dc output current and voltage are double the half-wave case and are given by

$$V_o = I_o R = \frac{1}{\pi} \int_0^\pi \sqrt{2} V \sin \omega t \, d\omega t = \frac{2\sqrt{2}}{\pi} V = 0.90V \quad (13.42)$$

The rms voltage across the load, and rms load current, are $\sqrt{2}$ greater than the half-wave case, specifically

$$V_{o\,rms} = \left[\frac{1}{\pi} \int_0^\pi 2V^2 \sin^2 \omega t \, d\omega t \right]^{1/2} = I_{o\,rms} R = V \quad (13.43)$$

and the power dissipated in the load, specifically the load resistor R , is

$$P_o = I_{o\,rms}^2 R = \frac{V^2}{R} \quad (13.44)$$

The ac current in the load is

$$I_{ac} = \sqrt{I_{o\,rms}^2 - I_o^2} = \frac{V}{R} \left[1 - \frac{8}{\pi^2} \right]^{1/2} \quad (13.45)$$

The load voltage harmonics are (twice the half-wave case, without the supply frequency component)

$$v_o(\omega t) = \frac{2\sqrt{2}V}{\pi} - \frac{4\sqrt{2}V}{\pi} \left[\frac{1}{1 \times 3} \cos 2\omega t + \frac{1}{3 \times 5} \cos 4\omega t + \frac{1}{n^2 - 1} \cos n\omega t \dots \right] \quad (13.46)$$

for $n=2, 4, 6, \dots$. The output voltage form factor $V_{o\,rms}/V_o = \pi/2\sqrt{2}=1.11$, hence $RF = 0.483$ and $pf = 1/\sqrt{2}$.

13.1.8 Single-phase full-wave bridge rectifier circuit with a resistive and back emf load, R-E

With an opposing emf E in the load circuit, the load current and voltage waveforms are as shown in figure 13.8b. Load current commences when

$$\omega t = \alpha = \sin^{-1} \frac{E}{\sqrt{2}V} \quad (13.47)$$

and ceases when

$$\omega t = \pi - \alpha = \pi - \sin^{-1} \frac{E}{\sqrt{2}V} \quad (13.48)$$

Diodes conduct every ac half cycle for a period $\theta = \pi - 2\alpha$, during which energy is delivered to both the load resistor R and load back emf E .

The load average and rms voltages are

$$\begin{aligned} V_o &= 2E \frac{\alpha}{\pi} + \frac{1}{\pi} \int_\alpha^{\pi-\alpha} \sqrt{2} V \sin \omega t \, d\omega t \\ &= 2E \frac{\alpha}{\pi} + \frac{2}{\pi} \sqrt{2} V \cos \alpha \end{aligned} \quad (13.49)$$

$$V_{o\,rms} = \left[2 \frac{\alpha}{\pi} E^2 + V^2 \left(1 - 2 \frac{\alpha}{\pi} + \frac{1}{\pi} \sin 2\alpha \right)^2 \right]^{1/2} \tag{13.50}$$

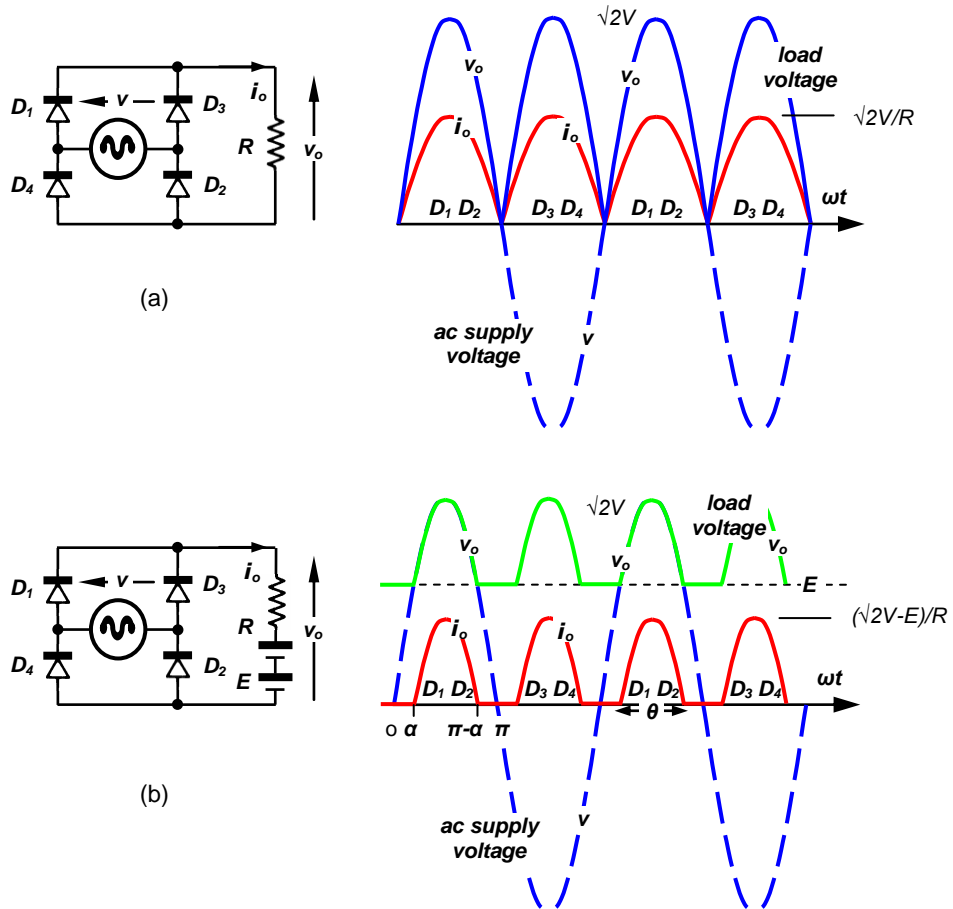

Figure 13.8. Single-phase full-wave rectifiers: (a) purely resistive load, R and (b) resistive load R with back emf, E.

The load average and rms currents are

$$I_o = \frac{1}{R} \left[\frac{2\sqrt{2}V}{\pi} \sin \frac{1}{2}\theta - E \frac{\theta}{\pi} \right] \tag{13.51}$$

which is double the half-wave case and

$$I_{o\,rms} = \frac{1}{R} \left[\frac{V^2}{\pi} \sin \theta - \frac{4\sqrt{2}}{\pi} V E \sin \frac{1}{2}\theta + (V^2 + E^2) \frac{\theta}{\pi} \right]^{1/2} \tag{13.52}$$

which is √2 greater than the half-wave case.

The total power delivered to the load is (double the half-wave case):

$$P_o = P_R + P_E = I_{o\,rms}^2 R + E I_o \tag{13.53}$$

Example 13.4: Full-wave rectifier with resistive and back emf load

A dc motor, with series armature resistance of 10Ω and a back emf of 100V dc, is fed via a full-wave rectifier from the single-phase 230V 50Hz ac mains. Calculate

- i. The average and rms motor voltages and currents, and diode maximum reverse voltage
- ii. The supply power factor and motor efficiency

Solution

With a 100V back emf, the circuit and waveforms in figure 13.8b are applicable.

The current starts conducting when

$$\omega t = \alpha = \sin^{-1} \frac{E}{\sqrt{2}V} = \sin^{-1} \frac{100V}{\sqrt{2} \times 230V} = 17.9^\circ$$

The current conducts for a period $\theta = \pi - 2\alpha = 180^\circ - 2 \times 17.9 = 144.2^\circ$, ceasing at $\omega t = \pi - \alpha = 162.1^\circ$.

i. The average and rms load currents and voltages are given by equations (13.49) to (13.52).

$$V_o = 2E \frac{\alpha}{\pi} + \frac{2}{\pi} \sqrt{2} V \cos \alpha$$

$$= 2 \times 100V \frac{17.9^\circ}{180^\circ} + \frac{2}{\pi} \sqrt{2} \times 230V \times \cos 17.9^\circ = 216.9V$$

$$I_o = \frac{1}{R} \left[\frac{2\sqrt{2}V}{\pi} \sin \frac{1}{2}\theta - E \frac{\theta}{\pi} \right]$$

$$= \frac{1}{10\Omega} \left[\frac{2\sqrt{2} \times 230V}{\pi} \sin \frac{1}{2} \times 144.2^\circ - 100V \times \frac{144.2^\circ}{180^\circ} \right] = 11.7A$$

$$V_{o\,rms} = \left[2 \frac{\alpha}{\pi} E^2 + V^2 \left(1 - 2 \frac{\alpha}{\pi} + \frac{1}{\pi} \sin 2\alpha \right) \right]^{1/2}$$

$$= \left[2 \times 100^2 \frac{17.9^\circ}{180^\circ} + 230^2 \left(1 - 2 \times \frac{17.9^\circ}{180^\circ} + \frac{1}{\pi} \sin 2 \times 17.9^\circ \right) \right]^{1/2} = 231.4V$$

$$I_{o\,rms} = \frac{1}{R} \left[\frac{V^2}{\pi} \sin \theta - \frac{4\sqrt{2}}{\pi} V E \sin \frac{1}{2}\theta + (V^2 + E^2) \frac{\theta}{\pi} \right]^{1/2}$$

$$= \frac{1}{10\Omega} \left[\frac{230^2}{\pi} \sin 144.2^\circ - \frac{4\sqrt{2}}{\pi} \times 230V \times 100V \times \sin \frac{1}{2} \times 144.2^\circ + (230^2 + 100^2) \frac{144.2^\circ}{180^\circ} \right]^{1/2}$$

$$= 14.43A$$

The diode maximum reverse voltage is $\sqrt{2} \times 230 + 100 = 425.3V$.

ii. The motor loss is the loss in the 10Ω resistance in the dc motor equivalent circuit

$$P_R = I_{o\,rms}^2 R = 14.43^2 \times 10\Omega = 2082.2W$$

The back emf represents the source of electrical energy converted to mechanical energy

$$P_E = E \times I_o = 100V \times 11.7A = 1170W$$

The supply power factor is defined as the ratio: supply power delivered to apparent supply power

$$pf = \frac{P}{S} = \frac{P_R + P_E}{V \times I_{o\,rms}} = \frac{2082.2W + 1170W}{230V \times 14.43A} = 0.98$$

The motor efficiency is

$$\eta = \frac{P_E}{P_R + P_E} = \frac{1170W}{2082.2W + 1170W} \times 100 = 36.0\%$$

♣

13.1.9 Single-phase, full-wave bridge rectifier circuit with an R-L load

Single-phase full-wave diode bridge circuits are shown in figures 13.9a and 13.9b. Both circuits appear identical as far as the load and supply are concerned. It will be seen in part b that two fewer diodes can be employed but this circuit requires a centre-tapped secondary transformer where each secondary has only a 50% copper utilisation factor. For the same output voltage, each of the secondary windings in figure 13.9b must have the same rms voltage rating as the single secondary winding of the transformer in figure 13.9a. The rectifying diodes in figure 13.9b experience twice the reverse voltage, ($2\sqrt{2}V$), as that experienced by each of the four diodes in the circuit of figure 13.9a, ($\sqrt{2}V$).

Figure 13.9c shows bridge circuit voltage and current waveforms. Assuming a 1:1(:1) transformer turns ratio, and with an inductive passive load, (no back emf) continuous load current flows, which is given by

$$i_o(\omega t) = \frac{\sqrt{2}V}{Z} \left[\sin(\omega t - \phi) + \frac{2 \sin \phi}{1 - e^{-\pi/\tan \phi}} \times e^{-\omega t/\tan \phi} \right] \quad 0 \leq \omega t \leq \pi \quad (13.54)$$

Appropriate integration of the load current squared, gives the rms load (and ac supply) current:

$$I_{rms} = \frac{V}{Z} \left[1 + 4 \sin^2 \phi \tan \phi \times (1 + e^{-\pi/\tan \phi}) \right]^{1/2} = I_s \quad (13.55)$$

The load experiences the transformer secondary rectified voltage which has a mean voltage (thence mean load current) of

$$V_o = \frac{1}{\pi} \int_0^\pi \sqrt{2}V \sin \omega t \, d\omega t = \bar{I}_o R = \frac{2\sqrt{2}V}{\pi} = 0.90V \quad (V) \quad (13.56)$$

Since the average inductor voltage is zero, the average resistor voltage equals the average R-L voltage.

The rms value of the load circuit voltage v_o is

$$V_{rms} = \sqrt{\frac{1}{2\pi} \int_0^{2\pi} (\sqrt{2}V \sin \omega t)^2 d\omega t} = V \tag{V} \tag{13.57}$$

From the load voltage definitions in section 13.5, the load voltage form factor is constant:

$$FF_v = \frac{V_{rms}}{V_o} = \frac{V}{2\sqrt{2}V/\pi} = \frac{\pi}{2\sqrt{2}} = 1.11 \tag{13.58}$$

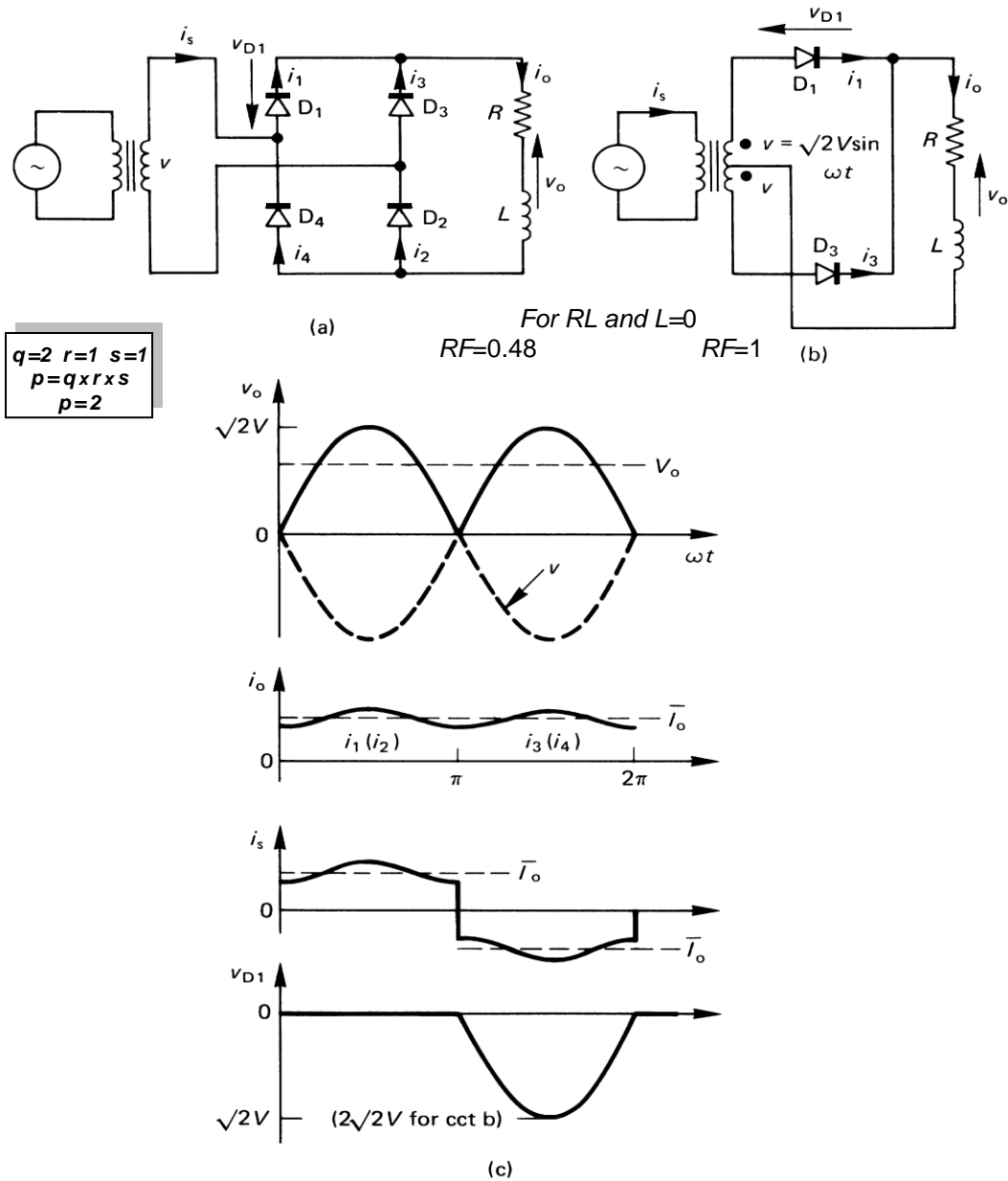

Figure 13.9. Single-phase full-wave rectifier bridge: (a) circuit with four rectifying diodes; (b) circuit with two (Graetz) rectifying diodes; and (c) circuit waveforms.

The load ripple voltage is

$$V_{Rl} \triangleq \sqrt{V_{rms}^2 - V_o^2} = \sqrt{V^2 - (2\sqrt{2}/\pi)^2 V^2} = V \sqrt{1 - 8/\pi^2} = 0.435V \tag{V} \tag{13.59}$$

hence the load voltage ripple factor is

$$RF_v \triangleq V_{Rl} / V_o = \sqrt{FF_v^2 - 1} \tag{13.60}$$

$$RF_v = \sqrt{1 - (2\sqrt{2}/\pi)^2} / 2\sqrt{2}/\pi = \sqrt{\pi^2/8 - 1} = 0.483 \quad FF_v = \pi / 2\sqrt{2} = 1.11 \quad \eta = 8 / \pi^2 = 0.81$$

which is significantly less (better) than the half-wave rectified value of 1.211 from equation (13.32).

The output voltages and currents (rms and average) can be derived from the voltage Fourier expansion in equation (13.46):

$$v_o(\omega t) = \frac{2\sqrt{2}V}{\pi} + \frac{2\sqrt{2}V}{\pi} \sum_{n=2,4,6}^{\infty} \frac{2}{n^2-1} \cos n\omega t \quad (13.61)$$

The first term is the average output voltage, as given by equation (13.56). Note the harmonic magnitudes decrease rapidly with increased order, namely $\frac{2}{3} : \frac{2}{15} : \frac{2}{35} : \frac{2}{63} : \dots$. The output voltage is therefore dominated by the dc component and the harmonic at 2ω .

The output current can be derived by dividing each voltage component by the appropriate load impedance at that frequency. That is

$$\begin{aligned} \bar{I}_o &= \frac{V_o}{R} = \frac{2\sqrt{2}V}{\pi R} \\ I_n &= \frac{V_n}{Z_n} = \frac{2\sqrt{2}V}{\pi} \times \frac{2}{\sqrt{R^2 + (n\omega L)^2}} \quad \text{for } n = 2, 4, 6.. \end{aligned} \quad (13.62)$$

The load rms current whence load power, critical load inductance, and power factor, are given by

$$\begin{aligned} I_{rms} &= \sqrt{I_o^2 + \sum_{n=2,4,6}^{\infty} \frac{1}{2} \times I_n^2} & P_L &= I_{rms}^2 R \\ pf &= \frac{P_L}{V I_{rms}} = \frac{I_{rms} R}{V} & L_{critical} &= \frac{R}{3 \times \omega} \quad (\text{see equation 11.67}) \end{aligned} \quad (13.63)$$

Each diode rms current is $I_{rms} / \sqrt{2}$. For the circuit in figure 13.9a, the transformer secondary winding rms current is I_{rms} , while for the centre-tapped transformer, for the same load voltage, each winding has an rms current rating of $I_{rms} / \sqrt{2}$ (implying a poorer transformer utilisation factor 0.813:0.671). The primary current rating is the same for both transformers and is related to the secondary rms current rating by the turns ratio. Power factor is independent of turns ratio.

13.1.9i - Single-phase full-wave bridge rectifier circuit with an output L-C filter

A – with an output L-C filter and continuous inductor current

Table 13.1 shows three typical single-phase, full-wave rectifier output stages, where part c is a typical output filtering stage used to obtain a near constant dc output voltage.

If it is assumed that the load inductance is large and the load resistance small such that continuous load current flows, then the bridge average output voltage \bar{V}_o is the same as the average voltage across the load resistor since the average voltage across the filter inductor is zero. From equation (13.61), the dominant load voltage harmonic is due to the second harmonic therefore the ac current is predominately the second harmonic current, $I_{o,ac} \approx I_{o,2}$. By neglecting the higher order harmonics, the various circuit currents and voltages can be readily obtained as shown in Table 13.1. From equation (13.61) the output voltage is given by

$$\begin{aligned} v_o(\omega t) &= \bar{V}_o + V_{o,2} \cos 2\omega t \\ &= \frac{2\sqrt{2}V}{\pi} + \frac{2\sqrt{2}V}{\pi} \times \frac{2}{n^2-1} \cos n\omega t \quad \text{for } n = 2 \\ &= \frac{2\sqrt{2}V}{\pi} + \frac{2\sqrt{2}V}{\pi} \times \frac{2}{3} \cos 2\omega t \\ &= 0.90V + 0.60V \times \cos 2\omega t \end{aligned} \quad (13.64)$$

With the filter capacitor across the load resistor, the average inductor current is equal to the average resistor current, since the average capacitor current is zero.

With continuous inductor current, the inductor current is

$$\begin{aligned} i_o(\omega t) &= \bar{I}_o + I_{o,2} \cos 2\omega t \\ &= \frac{\bar{V}_o}{R} + \frac{2}{3} \frac{\bar{V}_o}{Z_2} \cos 2\omega t = \frac{0.90V}{R} + \frac{0.60V}{\sqrt{R^2 + (2\omega L)^2}} \times \cos 2\omega t \end{aligned} \quad (13.65)$$

From equation (13.65) for continuous inductor current, the average current must be larger than the peak second harmonic current magnitude, that is

$$\begin{aligned} \bar{I}_o &> |I_{o,2}| \\ \frac{\bar{V}_o}{R} &> \frac{2}{3} \frac{\bar{V}_o}{Z_2} \end{aligned} \quad (13.66)$$

Since the load resistance must be low enough to ensure continuous inductor current, then $2\omega L > R$ such that $Z_2 = \sqrt{R^2 + (2\omega L)^2} \approx 2\omega L$. Equation (13.66) therefore gives the following load identity for continuous inductor current

$$\frac{1}{R} > \frac{2}{3} \frac{1}{Z_2} = \frac{1}{3\omega L} \text{ that is } \frac{L}{R} > \frac{1}{3\omega} \quad \text{generally } \left[\frac{L}{R} > \frac{1}{m(m^2 - 1)\omega} \right] \quad (13.67)$$

The load and supply (peak) ac currents are $I_{o,ac} = I_{s,ac} = I_{o,2}$. The output and supply rms currents are

$$I_{o,rms} = I_{s,rms} = \sqrt{I_o^2 + \frac{1}{2}I_{o,ac}^2} = \sqrt{I_o^2 + \frac{1}{2}I_{o,2}^2} \quad (13.68)$$

and the power delivered to resistance R in the load is

$$P_R = I_{o,rms}^2 R \quad (13.69)$$

B – with an output L-C filter and discontinuous inductor current

If the inductor current reduces to zero, at angle β , all the load current is provided by the capacitor. Its voltage falls to V_o ($< \sqrt{2} V$) and inductor current recommences when

$$v_L = \sqrt{2}V \sin \omega t - V_o \quad (13.70)$$

at an angle

$$\alpha = \sin^{-1} \frac{V_o}{\sqrt{2}V} \quad (13.71)$$

By integrating $v = L di/dt$ for i , the inductor current is of the form

$$i_L(\omega t) = \frac{1}{\omega L} (\sqrt{2}V (\cos \alpha - \cos \omega t) - V_o (\omega t - \alpha)) \quad (13.72)$$

where $\alpha \leq \omega t \leq \beta$. The voltage V_o is found from equation (13.72) by iterative techniques.

13.1.9ii Single-phase, full-wave bridge rectifier circuit with an R-L-E load

An R-L load incorporating a back emf E , is shown in Table 13.1.

For **continuous** output current

When continuous load current flows, the rectified supply is continuously impressed across the series L-R-E load, therefore the average and rms output voltages respectively are

$$\begin{aligned} \bar{V}_o &= \frac{1}{\pi} \int_0^\pi \sqrt{2}V_s \sin \omega t \, d\omega t = \frac{2\sqrt{2}}{\pi} V_s \\ V_o &= \sqrt{\frac{1}{\pi} \int_0^\pi (\sqrt{2}V_s \sin \omega t)^2 \, d\omega t} = V_s \end{aligned} \quad (13.73)$$

Hence the output voltage form and ripple factors are

$$\begin{aligned} FF_v &= \frac{V_o}{\bar{V}_o} = \frac{\pi}{2\sqrt{2}} \\ RF_v &= \sqrt{V_{FF}^2 - 1} = \sqrt{\frac{\pi^2}{8} - 1} \end{aligned} \quad (13.74)$$

If the input current is approximated by its fundamental, $4\bar{I}_o / \pi$, the following input characteristics are realised:

$$\text{input displacement factor} = DPF = \cos \phi_i = \cos 0^\circ = 1$$

$$\text{distortion factor} = DF_{i1} = \frac{I_{i1}}{I_o} = \frac{2\sqrt{2}}{\pi}$$

$$\text{power factor} = pf = DPF \times DF_{i1} = \frac{2\sqrt{2}}{\pi}$$

$$THD_{i1} = \sqrt{\frac{1 - DF_{i1}^2}{DF_{i1}^2}} \times 100 = \sqrt{\frac{\pi^2}{8} - 1} \times 100$$

The output current is found by solving

$$\sqrt{2}V_s \sin \omega t = Ri_o + L \frac{di_o}{dt} + E \quad (13.75)$$

which in steady state yields

$$i_o(t) = I_o e^{-\frac{\omega t}{\tan \theta}} + \sqrt{2} V_s \left[\sin(\omega t - \theta) - \frac{\sin \alpha}{\cos \theta} \right] \quad (13.76)$$

$$\text{where } \tan \theta = \frac{\omega L}{R}; \quad Z = \sqrt{R^2 + \omega^2 L^2}; \quad \sin \alpha = \frac{E}{\sqrt{2} V_s}$$

and the boundary conditions give

$$I_o = \frac{\sqrt{2} V_s}{Z} \frac{2 \sin \theta}{1 - e^{-\frac{\pi}{\tan \theta}}}$$

For continuous conduction, $i_o(\omega t = \theta) \geq 0$ in equation (13.76) gives the condition

$$\frac{2 \sin \theta}{1 - e^{-\frac{\pi}{\tan \theta}}} e^{-\frac{\alpha}{\tan \theta}} \geq \sin(\theta - \alpha) + \frac{\sin \alpha}{\cos \theta} \quad (13.77)$$

Table 11.1: Single-phase full-wave uncontrolled rectifier circuits – continuous inductor current

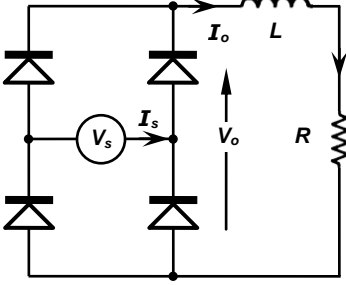
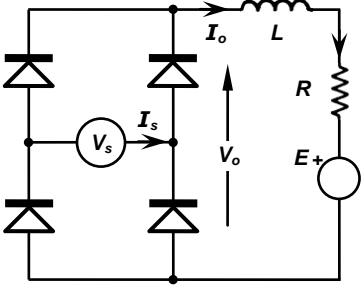
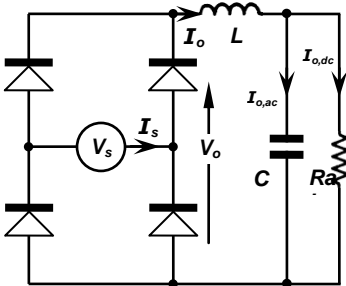
Full-wave rectifier circuit		2 nd harmonic current	average output current	output power
Load	circuit	$I_{o,2}$	\bar{I}_o	$P_R + P_E$
		(A)	(A)	(W)
(a) R-L see section 13.1.9i and 12.2.3 $\alpha = 0$		$\frac{V_{o,2}}{\sqrt{R^2 + (2\omega L)^2}}$	$\frac{\bar{V}_o}{R}$ $= \frac{2\sqrt{2}V}{\pi R}$	$I_{o,ms}^2 R$
(b) R-L-E see section 13.1.9ii and 12.2.4 $\alpha = 0$		$\frac{V_{o,2}}{\sqrt{R^2 + (2\omega L)^2}}$	$\frac{\bar{V}_o - E}{R}$ $= \frac{1}{R} \left(\frac{2\sqrt{2}V}{\pi} - E \right)$	$I_{o,ms}^2 R + \bar{I}_o E$
(c) L-R/C see section 13.1.9i		$\frac{V_{o,2}}{2\omega L}$	$\frac{\bar{V}_o}{R}$ $= \frac{2\sqrt{2}V}{\pi R}$	$I_{o,ms}^2 R = \bar{I}_o^2 R$

If the left hand side is less than the right hand side, **discontinuous** current flows in the load, and if the current extinction angle is β , then the average output voltage is given by

$$\bar{V}_o = \frac{1}{\pi} \left[\int_{\alpha}^{\beta} \sqrt{2} V_s \sin \omega t \, d\omega t + \int_{\beta}^{\pi+\alpha} E \, d\omega t \right]$$

$$\bar{V}_o = \frac{\sqrt{2} V_s}{\pi} \left[\cos \alpha - \cos \beta + (\pi + \alpha - \beta) \sin \alpha \right] \quad (13.78)$$

In the general solution to the circuit differential equation in equation (13.76), for discontinuous output current, (zero current boundary conditions), I_o for equation (13.76) becomes (during conduction)

$$I_o = \frac{\sqrt{2}V_s}{Z} \left[\sin(\theta - \beta) + \frac{\sin \alpha}{\cos \theta} \right]$$

The conduction period β is found by iteratively solving

$$\sin(\beta - \alpha) = \left[1 - e^{\frac{\alpha - \beta}{\tan \theta}} \right] \times \frac{\sin \alpha}{\cos \theta} - e^{\frac{\alpha - \beta}{\tan \theta}} \times \sin(\theta - \alpha) \quad (13.79)$$

Example 13.5: *Full-wave diode rectifier with an L-C filter and continuous load current*

A single-phase, full-wave, diode rectifier is supplied from a 230V ac, 50Hz voltage source and uses an L-C output filter with a resistor load, as shown in the last circuit in Table 13.1. The average inductor current is 10A with a 4A rms ripple current dominated by the 100Hz component. Ignoring diode voltage drops and initially assuming the output voltage is ripple free, determine

- i. dc output voltage, hence load resistance and power
- ii. dc filter inductance and its average voltage, whilst neglecting any capacitor voltage ripple
- iii. dc filter capacitance if its peak-to-peak ripple voltage is 5% the average voltage
- iv. diode average, rms, and peak current
- v. supply power factor

Solution

Since $\sqrt{2} I_{o,rms,2} < \bar{I}_o$ ($\sqrt{2} \times 4A < 10A$), the output current is continuous.

- i. The dc output voltage is $\bar{V}_o = 0.9 \times 230V = 207V$. Assuming the 207V is ripple free, that is, $V_{rms} = V_{dc}$, then the load resistance and power dissipated are

$$R = \frac{\bar{V}_o}{\bar{I}_o} = \frac{207V}{10A} = 20.7\Omega$$

$$P_R = \bar{V}_o \times \bar{I}_o = 207V \times 10A = 2070W$$

- ii. The 100Hz voltage component in the output voltage is given by equation (13.64), that is

$$\begin{aligned} V_{o,2} &= \frac{2\sqrt{2}V}{\pi} \times \frac{2}{n^2 - 1} \cos n\omega t \\ &= \frac{2\sqrt{2}V}{\pi} \times \frac{2}{3} \cos 2\omega t \\ &= 0.60 \times 230V \times \cos 2\omega t = 138 \times \cos 2\omega t \end{aligned}$$

which has an rms value of $138/\sqrt{2} = 97.6V$. The 100Hz rms current $I_{o,2} / \sqrt{2}$ produced by this voltage is 4A thus

$$\begin{aligned} \text{from } \frac{I_{o,2}}{\sqrt{2}} &= \frac{V_{o,2}}{2\omega L} \\ L &= \frac{V_{o,2}}{2\omega I_{o,2}} = \frac{97.6V}{2 \times 2\pi 50\text{Hz} \times 4A} = 38.8\text{mH} \end{aligned}$$

The average inductor voltage is zero.

- iii. From part i, the dc output voltage is 207V. The peak-to-peak ripple voltage is 5% of 207V, that is 10.35V. This gives an rms value of $10.35V / 2\sqrt{2} = 3.66V$. From

$$\begin{aligned} V_{o,2}/\sqrt{2} &= I_{o,2}/\sqrt{2} \times X_{c,100\text{Hz}} = \frac{I_{o,2}/\sqrt{2}}{2\omega C} \\ \Rightarrow C &= \frac{I_{o,2}}{2\omega \times V_{o,2}} = \frac{4A}{2 \times 2\pi 50\text{Hz} \times 3.66V} = 1.7\text{mF} \end{aligned}$$

- iv. The diode currents are

$$I_{D,rms} = I_{o,rms} / \sqrt{2} = \sqrt{I_o^2 + \frac{1}{2}I_{o,2}^2} / \sqrt{2} = \sqrt{10A^2 + 4A^2} / \sqrt{2} = 10.8A / \sqrt{2} = 7.64A$$

$$I_{D,rms} = I_{o,rms} / \sqrt{2} = \sqrt{I_o^2 + \frac{1}{2}I_{o,2}^2} \quad \hat{I}_D = \bar{I}_o + I_{o,2} = 10A + \sqrt{2} \times 4A = 15.7A$$

- v. The input and output rms current is

$$I_s = I_{o,rms} = \sqrt{I_o^2 + \frac{1}{2}I_{o,2}^2} = \sqrt{10A^2 + 4A^2} = 10.8A$$

Assuming the input power equals the output power, then from part *i*, $P_o = P_i = 2070\text{W}$. The supply power factor is

$$pf = \frac{P_i}{S} = \frac{P_i}{V_s I_s} = \frac{2070\text{W}}{230\text{V} \times 10.8\text{A}} = 0.83$$

♣

13.1.9iii - Single-phase full-wave bridge rectifier with highly inductive load– constant load current

With a highly inductive load, which is the usual practical case, virtually constant load current flows, as shown dashed in figure 13.9c. The bridge diode currents are then square wave 180° blocks of current of magnitude \bar{I}_o . The diode current ratings can now be specified and depend on the pulse number p . For this full-wave single-phase application each input cycle comprises two 180° output current pulses, hence $p=2$.

The mean current in each diode is

$$\bar{I}_D = \frac{1}{p} \bar{I}_o = \frac{1}{2} \bar{I}_o \quad (\text{A}) \quad (13.80)$$

and the rms current in each diode is

$$I_D = \frac{1}{\sqrt{p}} \bar{I}_o = \bar{I}_o / \sqrt{2} \quad (\text{A}) \quad (13.81)$$

whence the diode current form factor is

$$RF_{ID} = I_D / \bar{I}_D = \sqrt{p} = \sqrt{2} \quad (13.82)$$

Since the load current is approximately constant, power delivered to the load is

$$P_o \approx \bar{V}_o \bar{I}_o = \frac{8}{\pi^2} \times V^2 / R \quad (\text{W}) \quad (13.83)$$

The supply power factor is $pf = V_o / V = 2\sqrt{2}/\pi = 0.90$, since $\bar{I}_o = I_{rms}$.

13.1.9iv - Single-phase full-wave bridge rectifier circuit with a C-filter and resistive load

The capacitor smoothed single-phase full-wave diode rectifier circuit shown in figure 13.10a is a common power rectifier circuit used to obtain unregulated dc voltages. The circuit is simple and cheap but the input current has high peak and rms values, high harmonics, and a poor power factor. The full-wave rectified case is an extension of the half-wave case considered in section 13.1.5.

The capacitor reduces the ripple voltage, so large voltage-polarised capacitance is used to produce an almost constant dc output voltage. Isolation and voltage matching (step-up or step down) are obtained by using a transformer before the diode rectification stage as shown in figures 13.9a and b. The resistor R across the filter capacitor represents a resistive dissipative load.

As the ac supply voltage rises to its extremes each half cycle, as shown in figure 13.10b, a pair of rectifier diodes D1-D2 or D3-D4, alternately become forward biased at time $\omega t = \alpha$. The ac supply provides load resistor current and simultaneously charges the capacitor, its voltage having drooped whilst providing the load current during the previous diode non-conduction period. The capacitor charging current period θ_c around the ac supply extremes is short, giving a high peak to rms ratio of diode and supply current. When all the rectifier diodes are reverse biased at $\omega t = \beta$ because the capacitor voltage is greater than the instantaneous supply ac voltage, the capacitor supplies the load current and its voltage decreases with an R - C time constant until $\omega t = \pi + \alpha$. The output voltage and diode voltages, plus load current v_o/R , and capacitor current $C dv_o/dt$ are defined in Table 13.2.

The start of diode conduction, α , the diode current extinction angle, β , hence diode conduction period, θ_c , are specified by the following equations.

From $i_c + i_R = 0$ at $\omega t = \beta$:

$$\frac{\sqrt{2}V}{X} \cos \beta + \frac{\sqrt{2}V}{R} \sin \beta = 0 \quad (13.84)$$

$$\beta = \tan^{-1}(-\omega RC) = \pi - \tan^{-1}(\omega RC) \quad \frac{1}{2}\pi \leq \beta \leq \pi$$

By equating the two expression for output voltage at the boundary $\omega t = \pi + \alpha$ gives

$$\sqrt{2}V |\sin(\pi + \alpha)| = \sqrt{2}V \sin \beta \times e^{-(\pi + \alpha - \beta)/\tan \beta} \quad (13.85)$$

and a transcendental expression for α results:

$$\sin \alpha - \sin \beta \times e^{-(\pi + \alpha - \beta)/\omega RC} = 0 \quad (13.86)$$

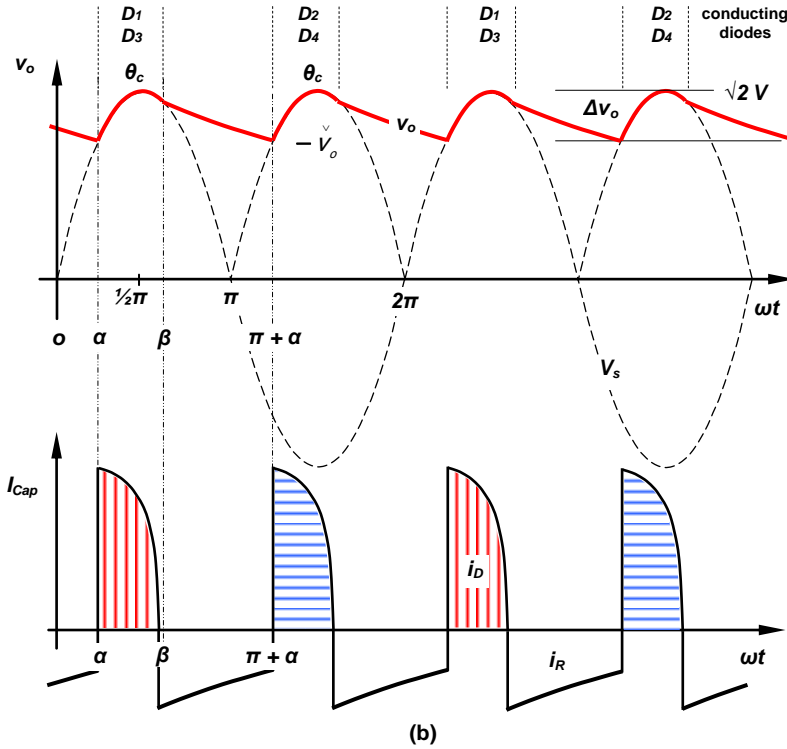
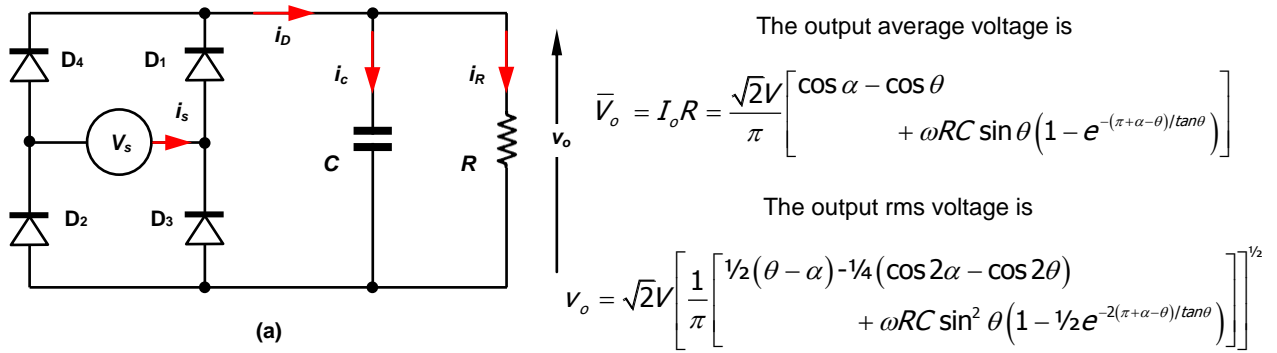

Figure 13.10. Single-phase full-wave rectifier bridge: (a) circuit with C-filter capacitor and (b) circuit waveforms.

Table 13.2: Single-phase, full-wave rectifier voltages and currents

$v_s(\omega t) = \sqrt{2}V \sin \omega t$		Diodes conducting	Diodes non-conducting
		$\alpha \leq \omega t \leq \beta$	$\beta \leq \omega t \leq \pi + \alpha$
Output voltage	$v_o(\omega t)$	$\sqrt{2}V \sin \omega t $	$\sqrt{2}V \sin \beta \times e^{-(\omega t - \beta)/\tan \beta}$
Diode voltage	$v_D(\omega t)$	0 and $-\sqrt{2}V \sin \omega t$	$-\sqrt{2}V \sin \beta \times e^{-(\omega t - \beta)/\tan \beta} + \sqrt{2}V \sin \omega t$
Capacitor current	$i_c(\omega t)$	$\frac{\sqrt{2}V}{X} \cos \omega t$	$\frac{\sqrt{2}V}{Z} \times e^{-(\omega t - \beta)/\tan \beta}$
Resistor current	$i_R(\omega t)$	$\frac{\sqrt{2}V}{R} \sin \omega t$	$\frac{\sqrt{2}V}{Z} \times e^{-(\omega t - \beta)/\tan \beta} = -i_c(\omega t)$
Diode bridge current	$I_D(\omega t) = i_c(\omega t) + i_R(\omega t)$	$\frac{\sqrt{2}V}{R \cos \phi} \times \sin(\omega t + \phi)$	0

The diode current conduction period θ_c is given by

$$\theta_c = \beta - \alpha \tag{13.87}$$

When the diodes conduct, R and C are in parallel and $\tan \phi = \omega C R$.

When the diodes are not conducting, the output circuit current flows in a series R - C circuit with a fundamental impedance of:

$$Z = \sqrt{R^2 + X^2} \quad \text{and} \quad X = \frac{1}{\omega C}$$

The resistor average voltage and current are

$$\bar{V}_R = \frac{\sqrt{2}V(1 - \cos\theta_c)}{\pi - \cos\beta} = \bar{I}_R R \quad (13.88)$$

The maximum output voltage occurs at $\omega t = \frac{1}{2}\pi$ when $v_o = \hat{V}_o = \hat{V}_s = \sqrt{2}V$, while the minimum output voltage occurs at the end of the capacitor discharge period when $\omega t = \alpha$ and $v_o = V_o = \sqrt{2}V \sin\alpha$. The output peak-to-peak ripple voltage is therefore the difference:

$$\Delta V_o = \hat{V}_o - \check{V}_o = \sqrt{2}V - \sqrt{2}V \sin\alpha = \sqrt{2}V(1 - \sin\alpha) \quad (13.89)$$

By assuming $\alpha \approx \frac{1}{2}\pi$, $\beta \approx \frac{1}{2}\pi$, and a series expansion for the exponent

$$\Delta V_o \approx \frac{\sqrt{2}V\pi}{\omega RC} = \frac{V}{\sqrt{2}f RC} \quad (13.90)$$

The ac source current is the sum of the diode currents, that is

$$i_s = i_{D1,2} - i_{D3,4} = i_R + i_c \quad (13.91)$$

when $\alpha < \omega t < \beta$. Otherwise $i_s = 0$.

Since the capacitor voltage is in steady-state, the average capacitor current is zero, thus for full-wave rectification, the average diode current is half the average load current.

The peak capacitor current occurs at $\omega t = \alpha$, when the diodes first conduct. From the capacitor current equation in Table 13.2:

$$\hat{I}_c = \sqrt{2}V\omega C \cos\alpha \quad (13.92)$$

From Table 13.2, the peak diode current occurs at the same time as the peak capacitor current, $\omega t = \alpha$:

$$\begin{aligned} \hat{I}_D &= i_c(\pi + \alpha) + i_R(\pi + \alpha) \\ &= \sqrt{2}V\omega C \cos\alpha + \frac{\sqrt{2}V}{R} \sin\alpha = \frac{\sqrt{2}V}{X} \cos\alpha + \frac{\sqrt{2}V}{R} \sin\alpha = \frac{\sqrt{2}V}{R} \frac{Z}{X} \sin(\alpha + \phi) \end{aligned} \quad (13.93)$$

Similar expressions can be derived for the half-wave rectifier case. For the non-conduction period, $\beta = 2\pi + \alpha$. The output ripple voltage is about twice that given by equation (13.90) and the average resistor voltage in equation (13.88) (after modification), is reduced. The diode PIV rating is $2\sqrt{2}V$ in both cases.

Example 13.6: Single-phase full-wave bridge rectifier circuit with C-filter and resistive load

A single-phase, full-wave, diode rectifier is supplied from a 230V ac, 50Hz voltage source and uses a capacitor output filter, 1000 μ F, with a resistor 100 Ω load, as shown in Figure 13.10a. Ignoring diode voltage drops, determine

- i. expressions for the output voltage
- ii. output voltage ripple Δv_o and the % error in using the approximation equation (13.90)
- iii. expressions for the capacitor current
- iv. diode peak current
- v. average load voltage and current

Assuming the output ripple voltage is triangular, estimate

- vi. average output voltage and rms output ripple voltage
- vii. capacitance C for $\Delta v_o = 2\%$ of the maximum output voltage

Solution

The supply voltage is $v_s = \sqrt{2} \times 230 \sin 2\pi 50t$, which has a peak value of $\hat{V}_s = 325.3V$.

$$\omega RC = 2\pi 50\text{Hz} \times 100\Omega \times 1000\mu\text{F} = 31.416 \text{ rad}$$

Thus $X = 1/\omega C = 3.1831\Omega$ and $Z = 100.0507\Omega$.

(5 figure accuracy is used because of the sensitivity of the applicable equations around $\alpha = 90^\circ$.)

From equation (13.84) the diode current extinction angle β is

$$\beta = \pi - \tan^{-1}(\omega RC) = \pi - \tan^{-1}(31.416\text{rad}) = 1.6026\text{rad} = 91.8^\circ$$

The diode current turn-on angle α is solve iteratively from equation (13.86), that is

$$\begin{aligned} \sin\alpha - \sin\beta \times e^{-(\pi+\alpha-\beta)/\omega RC} &= 0 \\ \sin\alpha - \sin 1.603 \times e^{-(\pi+\alpha-1.603)/31.416} &= 0 \end{aligned}$$

gives $\alpha = 1.16095 \text{ rad}$ or 66.5° . The diode conduction period is $\theta_c = \beta - \alpha = 1.6026 - 1.16095 = 0.44167\text{rad}$ or 25.3° .

i. From Table 13.2, the output voltage, which is the capacitor voltage, is given by

$$v_o(\omega t) = |\sqrt{2}V \sin \omega t| = |325.27V \times \sin \omega t| \quad 66.5^\circ \leq \omega t \leq 91.8^\circ$$

$$v_o(\omega t) = \sqrt{2} \times 230V \times \sin 1.6026\text{rad} \times e^{-(\omega t - 1.6026\text{rad})/31.416\text{rad}} = 325.13 \times e^{-(\omega t - 1.6026\text{rad})/31.416\text{rad}} \quad 91.8^\circ \leq \omega t \leq 246.5^\circ$$

ii. The output voltage ripple Δv_o is given by equation (13.89), that is

$$\Delta V_o = \sqrt{2}V(1 - \sin \alpha) = \sqrt{2} \times 230V \times (1 - \sin 1.16026) = 26.94V \text{ p-p}$$

From equation (13.90)

$$\Delta V_o \approx \frac{V}{\sqrt{2}fRC} = \frac{230V}{\sqrt{2} \times 50\text{Hz} \times 100\Omega \times 1000\mu\text{F}} = 32.5V$$

The approximation predicts a higher ripple: a +21% over-estimate.

iii. From Table 13.2, the capacitor current is

$$i_c(\omega t) = \sqrt{2}V\omega C \cos \omega t = \sqrt{2} \times 230V \times 2\pi \times 50\text{Hz} \times 1000\mu\text{F} \times \cos \omega t = 102.2 \times \cos \omega t$$

$$66.5^\circ \leq \omega t \leq 91.8^\circ$$

$$i_c(\omega t) = \frac{\sqrt{2}V \sin \beta}{R} \times e^{-(\omega t - \beta)/\omega RC} = \frac{\sqrt{2} \times 230V \times \sin 1.16}{100\Omega} \times e^{-(\omega t - 1.16)/31.4} = 3.0 \times e^{-(\omega t - 1.16)/31.4}$$

$$91.8^\circ \leq \omega t \leq 246.5^\circ$$

iv. The peak diode current is given by equation (13.93):

$$\begin{aligned} \hat{I}_D &= \sqrt{2}V\omega C \cos \alpha + \frac{\sqrt{2}V}{R} \sin \alpha \\ &= \sqrt{2} \times 230V \times 2\pi \times 50\text{Hz} \times 1000\mu\text{F} \times \cos 1.16026 + \frac{\sqrt{2} \times 230V}{100\Omega} \times \sin 1.16026 \\ &= 40.7A + 3A = 43.7A \end{aligned}$$

The peak diode current is dominated by the capacitor initial charging current of 40.7A

v. The average load voltage and current are given by equation (13.88)

$$\begin{aligned} \bar{V}_R &= \frac{\sqrt{2}V(1 - \cos \theta_c)}{\pi - \cos \beta} \\ &= \frac{\sqrt{2} \times 230V}{\pi} \times \frac{(1 - \cos 0.4417)}{-\cos 1.603} = 312.3V \\ \bar{I}_R &= \frac{\bar{V}_R}{R} = \frac{312.3V}{100\Omega} = 3.12A \end{aligned}$$

vi. If the ripple voltage is assumed triangular then

(a) The average output voltage is the peak output voltage minus half the ripple voltage, that is

$$\hat{V}_s - \frac{1}{2}\Delta v_o = \sqrt{2} \times 230V - \frac{1}{2} \times 26.9V = 311.8V$$

which is less than that given by the accurate equation (13.89), 312.3V.

(b) If the 26.9V p-p ripple voltage is assumed triangular then its rms value is $\frac{1}{2} \times 26.9 / \sqrt{3} = 7.8V$ rms.

vii. Re-arrangement of equation (13.90), which under-estimates the capacitance requirement for 2% ripple, gives

$$\begin{aligned} C &= \frac{V}{\sqrt{2}fR \times \Delta V_o} = \frac{\hat{V}_s}{2fR \times 2\% \text{ of } \hat{V}_s} = \frac{1}{2fR \times 2\%} \\ &= \frac{1}{2 \times 50\text{Hz} \times 100\Omega \times 0.02} = 5,000\mu\text{F} \end{aligned}$$

♣

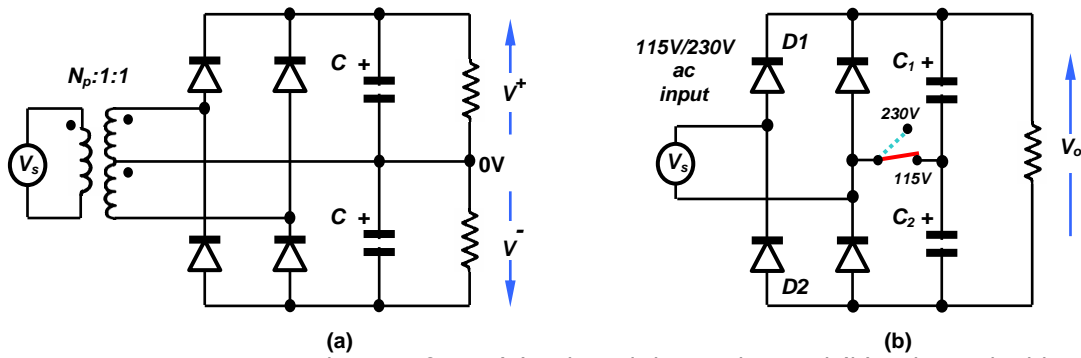

Figure 13.11. Bridge rectifiers: (a) split rail dc supplies and (b) voltage doubler.

13.1.9v - Other single-phase bridge rectifier circuit configurations

Figure 13.11a shows a transformer used to create a two-phase supply (each phase is 180° apart), which upon rectification produce equal split-rail dc output voltages, V^+ and V^- . The electrical characteristics can be analysed as in the case of the single-phase full-wave bridge rectifier circuit with a capacitive C -filter and resistive load, in section 13.1.9iv. In the split rail case, the rectifiers conduct every 180° , alternately feeding each output voltage rail capacitor. Thus the diode average and rms currents are increased by 2 and $\sqrt{2}$ respectively, above those of a conventional single phase rectifier.

The voltage doubler in figure 13.11b can be used in equipment that must be able to operate from both 115Vac and 230V ac voltage supplies, without the aid of a voltage-matching transformer. With the switch in the 115V position, the output is twice the peak of the input ac supply. The capacitor C_1 charges through diode $D1$, and when the supply reverses, capacitor C_2 charges through $D2$. Since C_1 and C_2 are in series, the output voltage is the sum $V_{C1}+V_{C2}$, where each capacitor is alternately charged (half-wave rectified) from the ac source V_s . The other, unused, two diodes remain reverse biased, and are only necessary if the dual input voltage function is required.

With the switch in the 230V ac position (open circuit), standard rectification occurs, with the two series capacitors charging simultaneously every half cycle. In dual frequency applications (110V ac, 60Hz and 230V ac, 50Hz), the capacitance requirements are based on the supply with the lower frequency, 50Hz.

13.2 Three-phase uncontrolled rectifier converter circuits

Single-phase supply circuits are adequate below a few kilowatts. At higher power levels, restrictions on unbalanced loading, line harmonics, current surge voltage dips, and filtering require the use of three-phase (or higher - polyphase) converter circuits. Generally it will be assumed that the output current is both continuous and smooth. This assumption is based on the dc load being highly inductive.

The characteristics of three-phase rectifiers with a purely resistive load are summarised in Table 13.8.

13.2.1 Three-phase half-wave rectifier circuit with an inductive R-L load

Figure 13.12 shows a half-wave (single way), three-phase diode rectifier circuit along with various circuit voltage and current waveforms. A transformer having a star connected secondary is required for neutral access, N.

The diode with the highest potential with respect to the neutral conducts a rectangular current pulse. As the potential of another diode becomes the highest, load current is transferred to that device, and the previously conducting device is reverse-biased and naturally (line) commutated. Note that the load voltage, hence current never reaches zero, when the load is passive (no opposing back emf).

In general terms, the mean output voltage for an n -phase p -pulse system is given by (see example 13.8)

$$V_o = \frac{1}{2\pi/p} \int_{-\pi/p}^{\pi/p} \sqrt{2}V \cos \omega t \, d\omega t \quad (\text{V})$$

$$= \sqrt{2}V \frac{\sin(\pi/p)}{\pi/p} \quad (\text{V}) \quad (13.94)$$

For a three-phase, half-wave circuit ($p = 3$) the mean output voltage, (thence average current) is

$$V_o = \bar{I}_o R = \frac{1}{2\pi/3} \int_{\pi/6}^{5\pi/6} \sqrt{2}V \sin \omega t \, d\omega t$$

$$= \sqrt{2}V \frac{1/2\sqrt{3}}{\pi/3} = 1.17 \times V \quad (\text{V}) \quad (13.95)$$

The rms load voltage is

$$V_{rms} = \sqrt{\frac{1}{2\pi/p} \int_{-\pi/p}^{\pi/p} (\sqrt{2}V)^2 \cos^2 \omega t d\omega t} = \sqrt{2}V \sqrt{\frac{1}{2} \left[1 + \frac{\sin 2\pi/p}{2\pi/p} \right]} \tag{13.96}$$

$$= \sqrt{2}V \left[\frac{3}{2\pi} \left(\frac{\pi}{3} + \frac{\sqrt{3}}{4} \right) \right]^{1/2} = 1.19 \times V$$

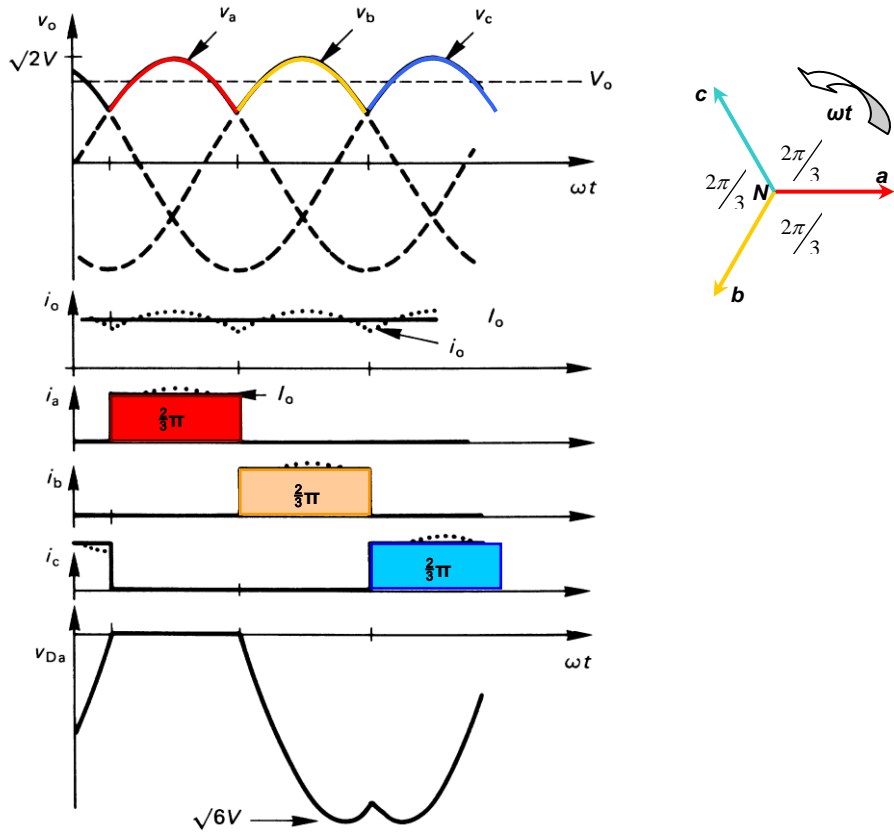
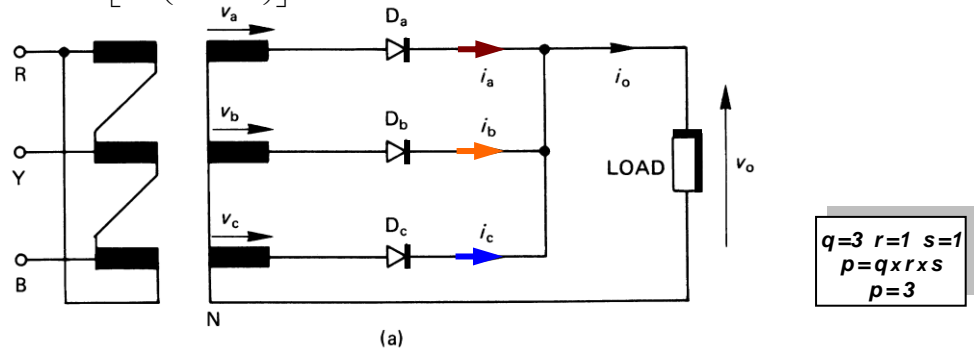

Figure 13.12. Three-phase half-wave diode rectifier: (a) circuit diagram and (b) circuit voltage and current waveforms.

The load voltage form factor is

$$FF_v = \frac{V_{rms}}{V} = \frac{\sqrt{\frac{1}{2} \left[1 + \frac{\sin 2\pi/p}{2\pi/p} \right]}}{\frac{\sin \pi/p}{\pi/p}} = 1.19V / 1.17V = 1.016 \quad \text{for } p = 3 \tag{13.97}$$

$$RF_v = \text{ripple factor} = \frac{\text{ac voltage across the load}}{\text{dc voltage across the load}} = \sqrt{\left(\frac{V_{rms}}{V} \right)^2 - 1} = 0.185 \tag{13.98}$$

The diode conduction angle is $2\pi/n$, namely $\frac{2}{3}\pi$. The peak diode reverse voltage is given by the maximum voltage between any two phases, $\sqrt{3}\sqrt{2} V = \sqrt{6} V$.

From equations (13.80), (13.81), and (13.82), for a constant output current, $\bar{I}_o = I_{o\ rms}$, the mean diode current is

$$\bar{I}_D = \frac{1}{n} \bar{I}_o = \frac{1}{3} \bar{I}_o \quad (A) \quad (13.99)$$

and the rms diode current is

$$I_D = \frac{1}{\sqrt{n}} I_{o\ rms} \approx \frac{1}{\sqrt{3}} \bar{I}_o = \frac{1}{\sqrt{3}} \bar{I}_o \quad (A) \quad (13.100)$$

The diode current form factor is

$$FF_{ID} = I_D / \bar{I}_D = \sqrt{3} \quad (13.101)$$

The input displacement factor $\cos\Phi$ is unity and the input power factor (and displacement factor), assuming diode square currents, is

$$pf = \frac{V_o I_o}{3V_s I_{rms}} = \frac{\frac{3\sqrt{6}}{2\pi} V_s I_o}{3V_s \frac{I_o}{\sqrt{3}}} = \frac{3}{\sqrt{2}\pi} = 0.675 \quad (13.102)$$

The load average and rms voltage, current and FF, RF, and power factor are the same for an *RL* load as for the resistive load case.

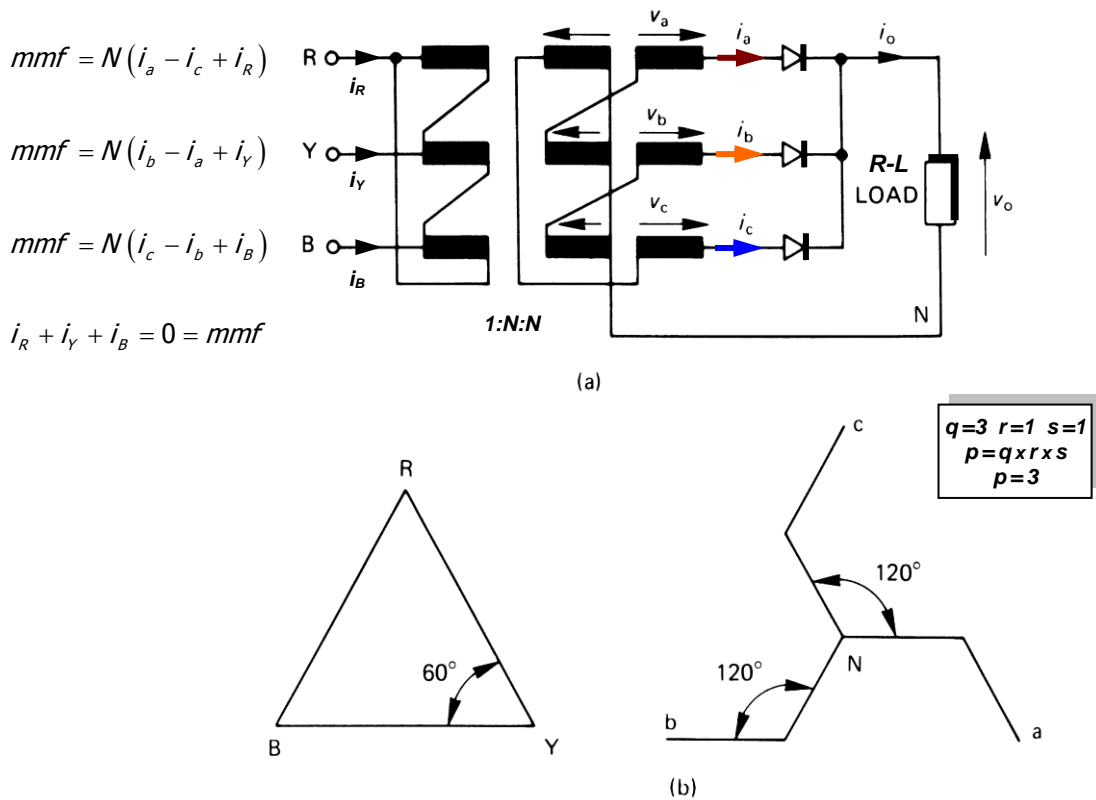

Figure 13.13. Three-phase zig-zag interconnected star winding, with three windings per limb, 1:N:N: (a) transformer connection showing zero dc mmf in each limb (phase) and (b) phasor diagram of transformer primary and secondary voltages.

If neutral is available, a transformer is not necessary. Then the full load current is returned via the neutral supply. This neutral current is generally not acceptable other than at low power levels. The simple delta-star connection of the supply in figure 13.12a is not appropriate since the unidirectional current in each phase is transferred from the supply to the transformer. This may result in increased magnetising current and iron losses if dc magnetisation occurs. As discussed in section 13.3.5, this problem is avoided in most cases by the special interconnected star winding, called zig-zag, shown in figure 13.13a and discussed in section 13.3.7. Each transformer limb has two equal voltage secondaries which are connected such that the magnetising forces balance. The resultant phasor diagram is shown in figure 13.13b. 15% more turns are needed than with a star connection. This transformer mmf problem resulting from half-wave rectification is considered in section 13.3 and chapter 22.

As the number of phases increases, the windings become less utilised per cycle since the diode conduction angle decreases, from π for a single-phase circuit, to $\frac{2}{3}\pi$ for the three-phase case.

13.2.2 Three-phase full-wave rectifier circuit with an inductive R-L load

Figure 13.14a shows a three-phase full-wave rectifier circuit where no neutral is necessary and it will be seen that two series diodes (not in the same bridge leg) are always conducting. One diode (one of D_1 , D_3 , or D_5 , at the highest potential) can be considered as being in the feed circuit, while the other (one of D_2 , D_4 , or D_6 , at the lowest potential) is in the return circuit. As such, the line-to-line voltage is impressed across the load. Given no two series connected bridge leg diodes conduct simultaneously, there are six possible diode pair combinations. The rectifier circuit waveforms in figure 13.14b show that the load ripple frequency is six times the supply. Each diode conducts for $\frac{2}{3}\pi$ and experiences a reverse voltage of the peak line voltage, $\sqrt{2} V_L$.

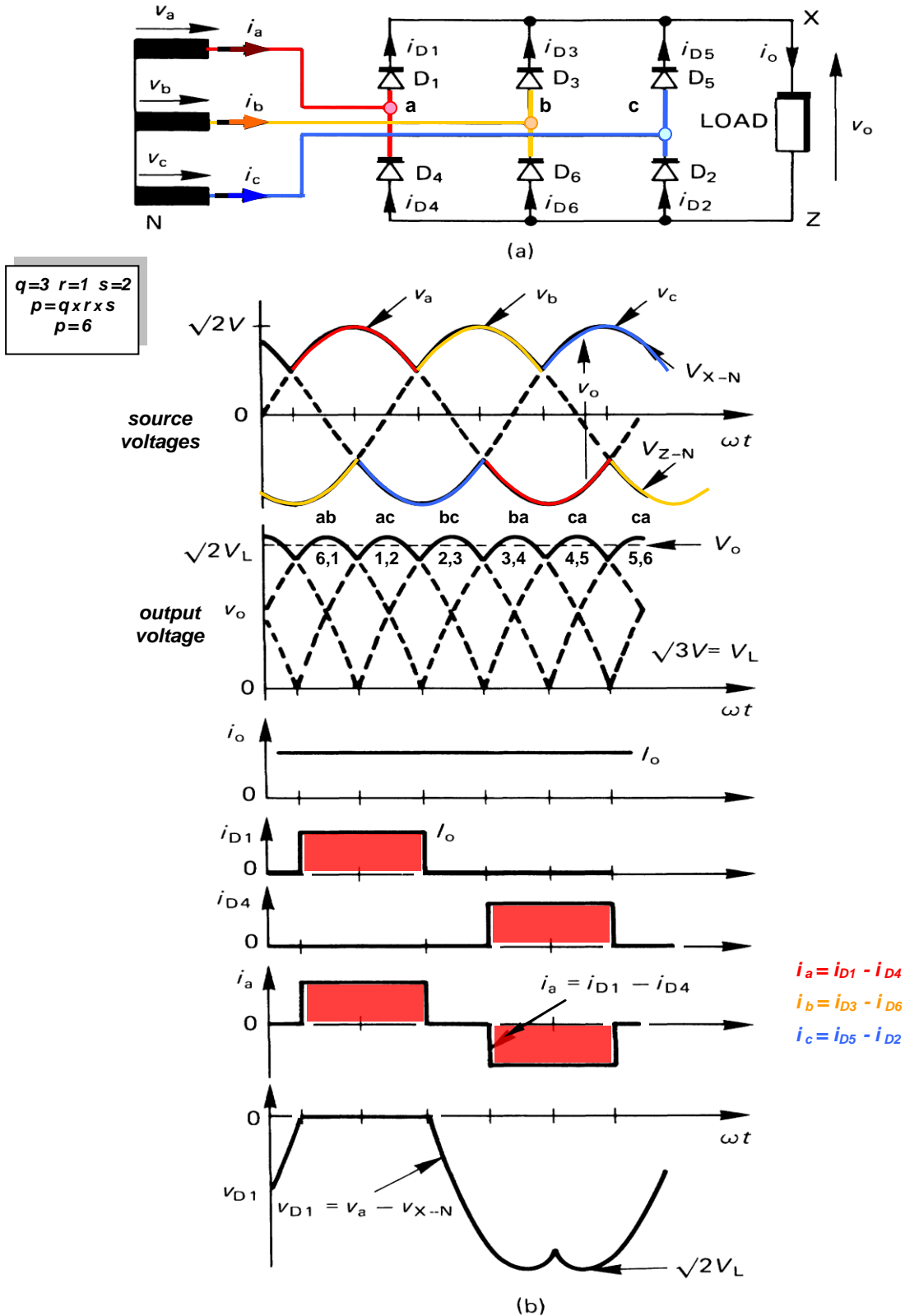

Figure 13.14. Three-phase full-wave bridge rectifier: (a) circuit connection and (b) voltage and current waveforms.

The mean load voltage is given by twice equation (13.95), that is

$$\begin{aligned} V_o &= I_o R = \frac{1}{\pi/3} \int_{\pi/3}^{2\pi/3} \sqrt{2} V_L \sin \omega t \, d\omega t \quad (\text{V}) \\ &= \sqrt{2} V \frac{\sqrt{3}}{\pi/3} = \frac{3}{\pi} \sqrt{2} V_L = 1.35 V_L = 2.34 V \end{aligned} \quad (13.103)$$

where V_L is the line-to-line rms voltage ($V_L = \sqrt{3} V$).

Generally the peak-to-peak ripple voltage for n -phases is $\sqrt{2} V - \sqrt{2} V \cos \frac{\pi}{n}$. (see Table 13.4)

The critical load inductance (see figure 12.12) for continuous load current, is $L_{critical} = \frac{R}{\frac{3}{2} \omega \times p} (p^2 - 1)$.

The output harmonics of a p -pulse voltage output are

$$\begin{aligned} V_{an} &= -1^{n/p} \times \frac{\sqrt{2} V}{\pi/p} \sin \frac{\pi}{p} \frac{2}{[n^2 - 1]} \\ &= -1^{n/p} \times V_o \times \frac{2}{[n^2 - 1]} \end{aligned} \quad (13.104)$$

where $n = mp$ and $m = 1, 2, 3, \dots$ and V_o is the mean output voltage given by equation (13.94).

The output voltage harmonics for $p = 6$ are given by

$$V_{on} = \frac{6 \hat{V}_L}{\pi (n^2 - 1)} \quad (13.105)$$

for $n = 6, 12, 18, \dots$

The rms output voltage is given by

$$\begin{aligned} V_{rms} &= \left(\frac{1}{2\pi/6} \int_{\pi/3}^{2\pi/3} \sqrt{2} V_L \sin^2 \omega t \, d\omega t \right)^{1/2} \\ &= V_L \sqrt{1 + \frac{3\sqrt{3}}{2\pi}} = 1.352 V_L \end{aligned} \quad (13.106)$$

Generally, for a p -pulse rectifier output, the rms output voltage is

$$V_{rms} = V_L \sqrt{1 + \frac{p}{2\pi} \sin^2 \frac{2\pi}{p}} \quad (13.107)$$

The load voltage form factor = $1.352/1.35 = 1.00091$, the ripple factor = $\sqrt{(\text{form factor}^2 - 1)} = 0.042$, power factor = 0.956 , and the efficiency is 0.998 .

13.2.2i Three-phase full-wave bridge rectifier circuit with continuous load current

If it is assumed that the load inductance is large, then (even with a load back emf), continuous load current flows and the dominate load current harmonic is due to the sixth harmonic current, that is let $I_{o,ac} = I_{o,6}$. By neglecting the higher order harmonics, the various circuit currents and voltages can be readily obtained as shown in Table 13.3. From equations (13.103) and (13.105) the output voltage is given by

$$\begin{aligned} v_o(\omega t) &= \bar{V}_o + V_{o,6} \cos 6\omega t \\ &= \frac{3}{\pi} \sqrt{2} V_L + \frac{3}{\pi} \sqrt{2} V_L \frac{2}{(n^2 - 1)} \cos n\omega t \quad \text{for } n = 6 \\ &= \frac{3}{\pi} \sqrt{2} V_L + \frac{3}{\pi} \sqrt{2} V_L \times \frac{2}{35} \cos 2\omega t \\ &= 1.35 V_L + 0.077 V_L \cos 2\omega t \end{aligned} \quad (13.108)$$

The fundamental voltage, hence current, V_o/R , is therefore much larger than the sixth harmonic current, $V_{o,6}/Z_6$, that is $\bar{I}_o > \hat{I}_{o,6}$. The load and supply ac currents are $I_{o,ac} = I_{s,ac} = I_{o,6}$. The output and supply rms currents are

$$I_{o,rms} = I_{s,rms} = \sqrt{\bar{I}_o^2 + I_{o,ac}^2} = \sqrt{\bar{I}_o^2 + I_{o,6}^2} \quad (13.109)$$

and the power delivered to resistance R in the load is

$$P_R = I_{o,rms}^2 R \quad (13.110)$$

13.2.2ii Three-phase full-wave bridge circuit with highly inductive load – constant load current

For a highly inductive load, that is a constant load current the average output voltage and current are given by equation (13.103), the rms output voltage by equation (13.106), and:

- the mean diode current is

$$\bar{I}_D = \frac{1}{n} \bar{I}_o = \frac{1}{3} \bar{I}_o \quad (\text{A}) \quad (13.111)$$

- and the rms diode current is

$$I_{D,rms} = \frac{1}{\sqrt{n}} I_{o,rms} \approx \frac{1}{\sqrt{n}} \bar{I}_o = \frac{1}{\sqrt{3}} \bar{I}_o \quad (\text{A}) \quad (13.112)$$

- and the power factor for a constant load current is

$$pf = \frac{3}{\pi} = 0.955 \quad (13.113)$$

The rms input line currents are

$$I_{L,rms} = \sqrt{\frac{2}{3}} I_{o,rms} \quad (13.114)$$

The diode current form factor is

$$FF_{ID} = I_{D,rms} / \bar{I}_D = \sqrt{3} \quad (13.115)$$

The diode current ripple factor is

$$RF_{ID} = \sqrt{FF_{ID}^2 - 1} = \sqrt{2} \quad (13.116)$$

A phase voltage and current are given by

$$v_a = \sqrt{2} V \sin \omega t \quad (13.117)$$

$$i_a = \frac{2\sqrt{3}}{\pi} \bar{I}_o \left[\sin \omega t + \frac{\sin(n-1)\omega t}{n-1} + \frac{\sin(n+1)\omega t}{n+1} \right] \quad n = 6, 12, 18, \dots \quad (13.118)$$

with phases b and c shifted by $\frac{2}{3}\pi$. That is substitute ωt in equations (13.117) and (13.118) with $\omega t \pm \frac{2}{3}\pi$.

Each load current harmonic n produces harmonics $n+1$ and $n-1$ on the input current.

The total load instantaneous power is given by

$$p(\omega t) = 3 \times \sqrt{2} V \bar{I}_o \times \left(\frac{1}{2} - \frac{\cos n\omega t}{n^2 - 1} \right) \quad (13.119)$$

The supply apparent power is

$$S = \sqrt{3} V_L I_{s,rms} \quad (13.120)$$

while the ac power, in terms of apparent ac resistance, is

$$P_{ac} = 3 \times \frac{V^2}{R_{ac}} \quad (13.121)$$

Using the output voltage from equation (13.103), the output power is

$$P_{dc} = \left(\sqrt{2} V \frac{\sqrt{3}}{\pi / 3} \right)^2 / R_{dc} \quad (13.122)$$

Since $P_{ac} = P_{dc}$, then $R_{dc} = 2 \left(\frac{9}{\pi^2} \right) R_{ac} \approx 2R_{ac}$.

At the ac input, for a constant load current:

The rms value of the fundamental line current

$$I_{L1,rms} = \frac{2\sqrt{3}}{\pi} I_o / \sqrt{2} = \frac{\sqrt{6}}{\pi} I_o = 0.78 I_o$$

The input distortion, DF , is

$$DF = \frac{I_{o,1}}{I_o} = \frac{\sqrt{6}/\pi I_o}{\sqrt{2/3} I_o} = \frac{3}{\pi} = 0.955 \quad (13.123)$$

The input power factor, with unity displacement power factor, is therefore

$$pf = DF \times DPF = \frac{3}{\pi} = 0.955 \quad (13.124)$$

The input total harmonic distortion is

$$THD = \frac{\sqrt{I_L^2 - I_{L,1}^2}}{I_{L,1}} = \frac{\sqrt{\frac{2}{3} I_o^2 - \frac{6}{\pi^2} I_o^2}}{\sqrt{6}/\pi I_o} = 0.3108 \quad (13.125)$$

Table 13.3: Three-phase full-wave uncontrolled rectifier circuits

Full-wave rectifier circuit		6 th harmonic current	average output current	output power
load	circuit	$I_{o,6}$ (A)	\bar{I}_o (A)	$P_R + P_E$ (W)
(a) R-L see section 13.2.2i		$\frac{V_{o,6}}{\sqrt{R^2 + (6\omega L)^2}}$	$\frac{\bar{V}_o}{R}$	$I_{o,rms}^2 R$
(b) 13.2.2iii R-L-E		$\frac{V_{o,6}}{\sqrt{R^2 + (6\omega L)^2}}$	$\frac{\bar{V}_o - E}{R}$	$I_{o,rms}^2 R + \bar{I}_o E$
(c) R-L-C		$\frac{V_{o,6}}{6\omega L}$	$\frac{\bar{V}_o}{R}$	$I_{o,rms}^2 R = \bar{I}_o^2 R$
(d) 13.2.2iv R-C		-	$\frac{\bar{V}_o}{R}$	$I_{o,rms}^2 R$

13.2.2iii Three-phase full-wave bridge circuit with highly inductive load with an EMF source

With continuous load current, the output voltage and input characteristics are unaffected by a load back emf, with the average and rms output voltages given by equations (13.103) and (13.106) respectively. The input power factor and distortion factor are $3/\pi$, as per equation (13.125). The output, that is, load current, is found from

$$L \frac{di_o}{dt} + Ri_o + E = \sqrt{2}V_s \sin \omega t \quad \frac{1}{3}\pi \leq \omega t \leq \frac{2}{3}\pi$$

$$i_o(t) = I_o e^{\frac{\omega t - \frac{1}{3}\pi}{\tan \phi}} + \frac{\sqrt{2}V_s}{Z} \left[\sin(\omega t - \phi) - \frac{\sin \alpha}{\cos \phi} \right] \quad (13.126)$$

$$\text{where } \tan \phi = \frac{\omega L}{R}; \quad Z = \sqrt{R^2 + \omega^2 L^2}; \quad \sin \alpha = \frac{E}{\sqrt{2}V_s}; \quad \text{and } I_o = \frac{\sqrt{2}V_s}{Z} \frac{\sin \phi}{1 - e^{\frac{-\pi/3}{\tan \phi}}}$$

13.2.2iv Three-phase full-wave bridge circuit with capacitively filtered load resistance

Part d in Table 13.1 shows a three-phase full-wave rectifier circuit with a parallel R-C load.

Interval $\alpha \leq \omega t \leq \beta$

In the interval $\alpha \leq \omega t \leq \beta$, two diodes are conducting connecting the supply voltage across the load. The input current provides both the resistive load and the output filter capacitor across the load.

$$i_s = i_o + i_c = \frac{v_o}{R} + C \frac{dv_o}{dt} \text{ where } v_o = V_s = \sqrt{2}V_s \sin \omega t \quad (V_s \text{ is the line-to-line voltage})$$

That is

$$\begin{aligned} i_s &= i_o + i_c \\ i_s(t) &= \frac{\sqrt{2}V_s \sin \omega t}{R} + \sqrt{2}V_s \omega C \cos \omega t \\ &= \frac{\sqrt{2}V_s}{R} \sqrt{1 + \omega^2 C^2 R^2} \cos(\omega t - \phi) = \frac{\sqrt{2}V_s}{R \cos \phi} \cos(\omega t - \phi) \end{aligned} \tag{13.127}$$

where $\tan \phi = \frac{1}{\omega RC}$ and $\beta = \frac{1}{2}\pi + \phi$

Interval $\beta \leq \omega t \leq \alpha + \frac{1}{3}\pi$

In the interval $\beta \leq \omega t \leq \alpha + \frac{1}{3}\pi$, the bridge diodes are all reverse biased, isolating the source from the load (discontinuous input current), and the load current is provided from the output capacitor.

$$i_s = i_o + i_c = 0 = \frac{v_o}{R} + C \frac{dv_o}{dt}$$

In satisfying a boundary condition yields

$$\begin{aligned} v_o(t) = v_c(t) = v_R(t) &= \\ &= \sqrt{2}V_s \frac{\omega RC}{\sqrt{1 + \omega^2 R^2 C^2}} e^{-\frac{(\omega t - \beta)}{\omega RC}} = \sqrt{2}V_s \frac{R \cos \phi}{X_C} \times e^{-\frac{(\omega t - \beta)}{\omega RC}} \\ &= i_o R \end{aligned} \tag{13.128}$$

Equating the two output voltage expressions, equations (13.127) and (13.128), at the boundary $\omega t = \alpha + \frac{1}{3}\pi$ yields an equation for determining α iteratively.

$$\sin \alpha = \frac{\omega RC}{\sqrt{1 + \omega^2 R^2 C^2}} e^{-\frac{(\alpha - \frac{1}{6}\pi - \tan^{-1} \frac{1}{\omega RC})}{\omega RC}}$$

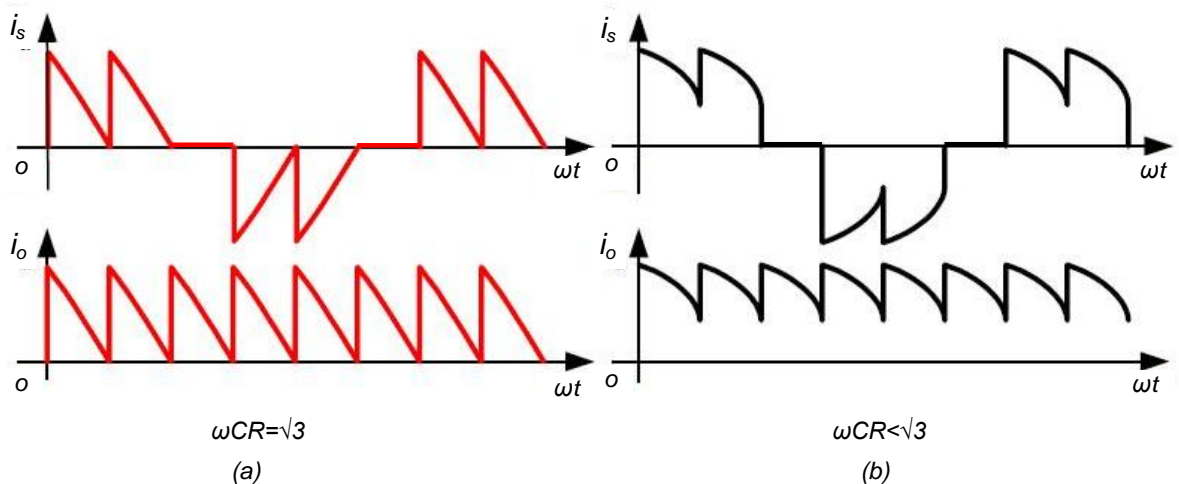

Figure 13.15. Three-phase full-wave bridge rectifier a capacitive output filter: (a) verge of discontinuous conduction and (b) continuous current conduction.

Example 13.7: Three-phase full-wave rectifier

The full-wave three-phase dc rectifier in figure 13.14a has a three-phase 415V 50Hz source (240V phase), and a 10Ω, 50mH, series load. During the problem solution, verify that the only harmonic that need be considered is the sixth.

Determine

- i. average output voltage and current
- ii. rms load voltage and the ac output voltage
- iii. rms load current hence power dissipated and supply power factor
- iv. load power percentage error in assuming a constant load current
- v. diode average and rms current requirements

Solution

i. From equation (13.103) the average output voltage and current are

$$V_o = I_o R = 1.35 V_L = 1.35 \times 415 \text{V} = 560.45 \text{V}$$

$$I_o = \frac{V_o}{R} = \frac{560.45 \text{V}}{10 \Omega} = 56.045 \text{A}$$

ii. The rms load voltage is given by equation (13.106)

$$V_{rms} = 1.352 V_L = 1.352 \times 415 \text{V} = 560.94 \text{V}$$

The ac component across the load is

$$\begin{aligned} V_{ac} &= \sqrt{V_{rms}^2 - V_o^2} \\ &= \sqrt{560.94 \text{V}^2 - 560.447 \text{V}^2} = 23.52 \text{V} \end{aligned}$$

iii. The rms load current is calculated from the harmonic currents, which are calculated from the harmonic voltages given by equation (13.105).

harmonic n	$V_n = \frac{6 \hat{V}_L}{\pi(n^2 - 1)}$	$Z_n = \sqrt{R^2 + (n\omega L)^2}$	$I_n = \frac{V_n}{Z_n}$	$\frac{1}{2} I_n^2$
0	(560.45)	10.00	56.04	(3141.01)
6	32.03	94.78	0.34	0.06
12	7.84	188.76	0.04	0.00
Note the 12 th harmonic current is not significant			$I_o^2 + \sum \frac{1}{2} I_n^2 =$	3141.07

The rms load current is

$$\begin{aligned} I_{rms} &= \sqrt{I_o^2 + \sum \frac{1}{2} I_n^2} \\ &= \sqrt{3141.07} = 56.05 \text{A} \end{aligned}$$

The power absorbed by the 10Ω load resistor is

$$P_L = I_{rms}^2 R = 56.05 \text{A}^2 \times 10 \Omega = 31410.7 \text{W}$$

The supply power factor is

$$pf = \frac{P_L}{V_{rms} I_{rms}} = \frac{P_L}{\sqrt{3} V_L I_L} = \frac{31410.7 \text{W}}{\sqrt{3} \times 415 \text{V} \times \sqrt{\frac{2}{3}} \times 56.05 \text{A}} = 0.955$$

This power factor of 0.955 is as predicted by equation (13.113), $\frac{3}{\pi}$, for a constant current load.

iv. The percentage output power error in assuming the load current is constant is given by

$$1 - \frac{\tilde{P}_L}{P_L} = 1 - \frac{I_o^2 R}{I_{rms}^2 R} = 1 - \frac{56.045 \text{A}^2 \times 10 \Omega}{56.05 \text{A}^2 \times 10 \Omega} = 1 - \frac{31410.1 \text{W}}{31410.7 \text{W}} = 0\%$$

v. The diode average and rms currents are given by equations (13.111) and (13.112)

$$\bar{I}_D = \frac{1}{3} \bar{I}_o = \frac{1}{3} \times 56.045 = 18.7 \text{A}$$

$$I_{D,rms} = \frac{1}{\sqrt{3}} I_{o,rms} = \frac{1}{\sqrt{3}} \times 56.05 = 23.4 \text{A}$$

Example 13.8: Rectifier average load voltage

Derive a general expression for the average load voltage of a p -pulse rectifier.

Solution

Figure 13.16 defines the general output voltage waveform where p is the output pulse number per cycle of the ac supply. From the output voltage waveform

$$\begin{aligned}
 V_o &= \frac{1}{2\pi/p} \int_{-\pi/n}^{\pi/n} \sqrt{2}V \cos \omega t \, d\omega t \\
 &= \frac{\sqrt{2}V}{2\pi/p} (\sin(\pi/p) - \sin(-\pi/p)) = \frac{\sqrt{2}V}{2\pi/p} 2\sin(\pi/p) \\
 V_o &= \frac{\sqrt{2}V}{\pi/p} \sin(\pi/p) \quad (V)
 \end{aligned}$$

where

for $p = 2$ for the single-phase ($n = 1$) full-wave rectifier in figure 13.9.
 for $p = 3$ for the three-phase ($n = 3$) half-wave rectifier in figure 13.12.
 for $p = 6$ for the three-phase ($n = 3$) full-wave rectifier in figure 13.14.

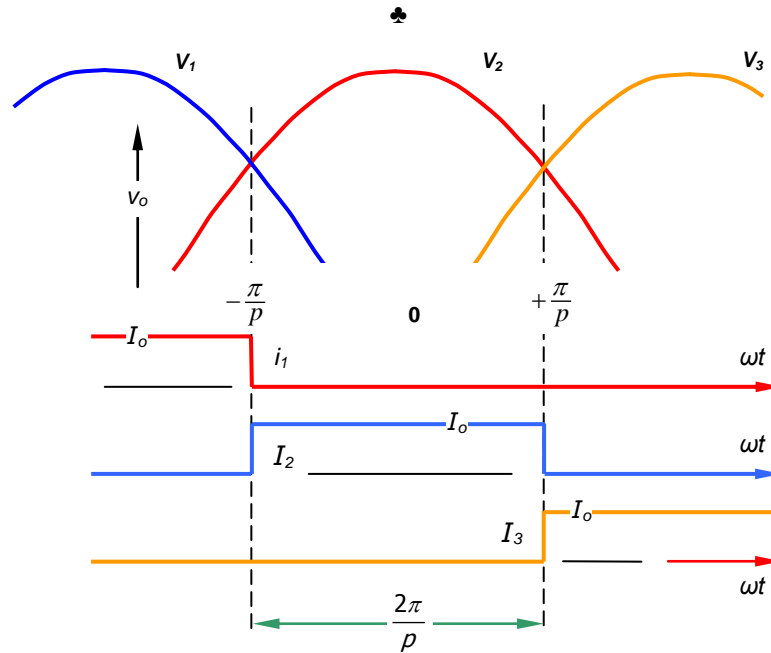

Figure 13.16. A half-wave n -phase uncontrolled rectifier: output voltage and current waveforms.

The output waveform smoothness, termed harmonic or ripple factor RF is defined by

$$\begin{aligned}
 \text{Ripple factor} = RF_v &= \frac{\text{effective values of ac } V}{\text{average value of } V} = \frac{V_{ac}}{V_{dc}} \\
 &= \sqrt{\frac{V_{rms}^2 - V_{dc}^2}{V_{dc}^2}} = \sqrt{\frac{V_{rms}^2}{V_{dc}^2} - 1} = \sqrt{FF^2 - 1}
 \end{aligned}$$

$$\text{where } V_{ac} = \left[\sum_{n=1}^{\infty} \frac{1}{2} (v_{an}^2 + v_{bn}^2) \right]^{1/2}$$

where FF is termed the form factor. RF_v is a measure of the voltage harmonics in the output voltage.

Ripple factors for constant output current rectifiers with different number of pulses, n

n	2	3	6	12	∞
%	48.2	18.27	4.18	0.994	0

13.3 Uncontrolled rectifier input current harmonics and power factor compensation

As rectifier phase and pulse number increase, input power factor and input current THD decrease. Three phase rectifiers, without input filtering, generally cannot comply with current harmonic standards, such as IEEE Std. 519-1992, Table 13.4. Independent of the short circuit ratio, SCR, the lower order harmonics, 5th and 7th, present the most difficulty (although limits increase as SCR increases). Passive filtering may not be viable because of large LC component sizes, tolerances, ageing, noise, and costs.

An active front end, based on boost converters as in chapter 15.8 and chapter 26.3.1 present an alternative that offer high quality sinusoidal input currents at unity power factor. In such active topologies, as in figure 13.17, the input converter (three-phase inverter bridge) is rated at the link power rating, and the input inductors L_s are rated at the input phase current level. For a given THD, the input inductance is inversely related to inverter switching frequency.

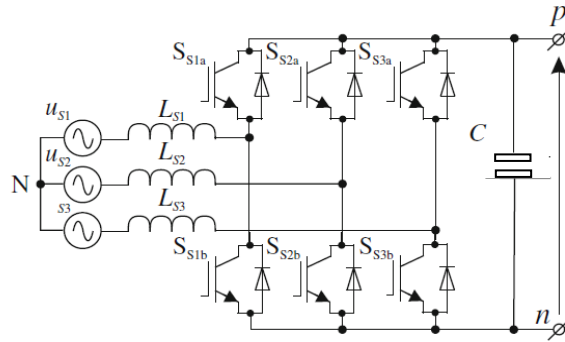

Figure 13.17. Active front end, reversible three-phase ac to dc converter.

The shunt compensator is a FACTS device and offers an active front end alternative in three phase 415V ac to dc conversion stages found in many grid connected power electronics applications. Such a configuration, as in figure 13.18 offers distinct advantages: the current ratings of the shunt inverter and inductors are less than one third the ac line current, since the shunt only processes the harmonics and VAR for power factor compensation. The dc link capacitor voltage must exceed the peak of the line voltage, although triplen injection reduces the necessary voltage overhead.

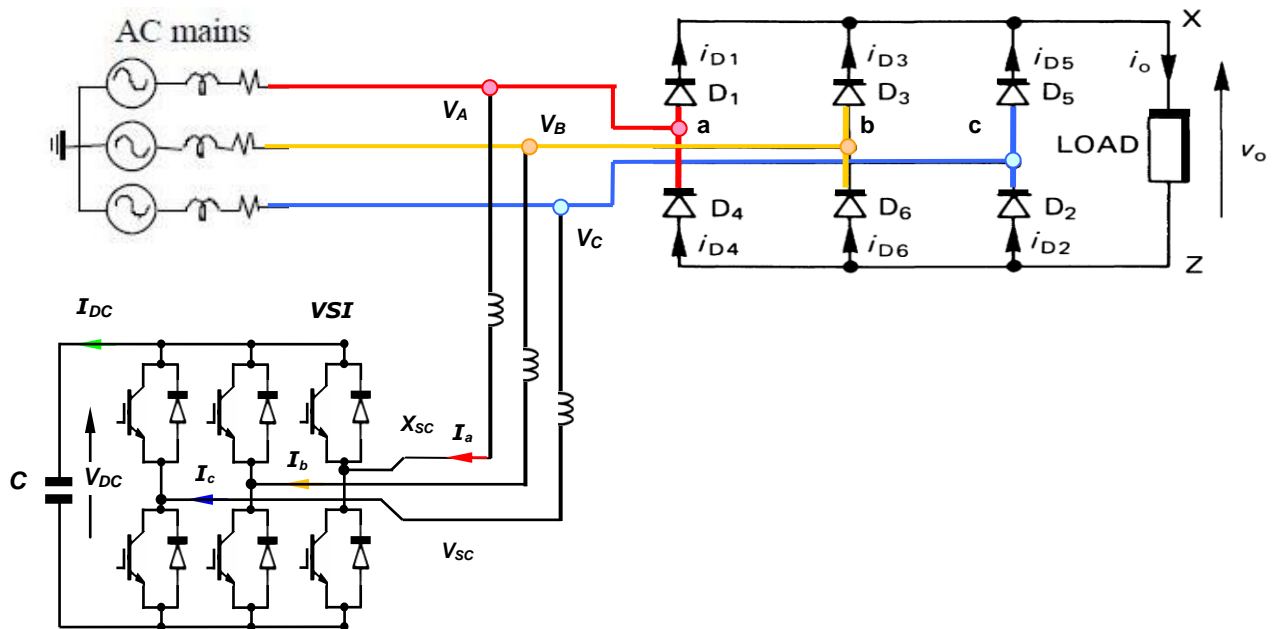

Figure 13.18. Shunt compensation (for VAR and harmonics) of an uncontrolled rectifier.

Table 13.4: Current Harmonic Limits

Maximum Harmonic Current Distortion in % of I_L						
Individual Harmonic Order (Odd Harmonics)						
I_{SC} / I_L	<11	$11 \leq h < 17$	$17 \leq h < 23$	$23 \leq h < 35$	$35 \leq h$	TDD
<20*	4.0	2.0	1.5	0.6	0.3	5.0
20<50	7.0	3.5	2.5	1.0	0.5	8.0
50<100	10.0	4.5	4.0	1.5	0.7	12.0
100<1000	12.0	5.5	5.0	2.0	1.0	15.0
>1000	15.0	7.0	6.0	2.5	1.4	20.0

Even harmonics are limited to 25% of the harmonic limits, TDD refers to Total Demand Distortion and is based the average maximum demand current at the fundamental frequency, taken at PCC.

*All power generation equipment is limited to these values of current distortion regardless of I_{SC} , I_L .

I_{SC} = maximum short current at the PCC
 I_L = maximum demand load current (fundamental) at the PCC
 h = harmonic number

13.4 DC MMFs in converter transformers

Half-wave rectification – whether controlled, semi-controlled or uncontrolled, is notorious for producing a dc *mmf* in transformers and triplen harmonics in the ac supply neutral of three-phase circuits. Generally, a transformer based solution can minimise the problem. In order to simplify the underlying concepts, a constant dc load current I_o is assumed, that is, the load inductance is assumed infinite. The transformer is assumed linear, no-load excitation is ignored, and the ac supply is assumed sinusoidal. Independent of the transformer and its winding connection, the average output voltage from a rectifier, when the rectifier bridge input rms voltage is V_B and there are q pulses in the output, is given by

$$V_o = \frac{\hat{V}_B}{2\pi/q} \int_{-\pi/q}^{\pi/q} \cos \omega t \, d\omega t = \hat{V}_B \frac{\sin \pi/q}{\pi/q} \tag{13.129}$$

The rectifier bridge rms voltage output is dominated by the dc component and is given by

$$V_{o,rms} = \frac{q}{2\pi} \int_{-\pi/q}^{\pi/q} 2V_B^2 \cos^2(\omega t) \, d\omega t = V_B \sqrt{1 + \frac{q}{2\pi} \sin \frac{2\pi}{q}} \tag{13.130}$$

The Fourier expression for the output voltage, which is also dominated by the dc component, is

$$v_o(\omega t) = V_o + V_o \sum_{k=1}^{\infty} \frac{2(-1)^{k+1}}{k^2 n^2 - 1} \cos k n \omega t \tag{13.131}$$

Table 13.5: Rectifier characteristics with q phases (see section 13.8)

q phases	Parallel connected secondary windings	Series connected secondary windings	
	Star, thus neutral always exists	Polygon, hence no neutral	
	$v_1 = \sqrt{2}V \sin[\omega t]$ $v_2 = \sqrt{2}V \sin\left[\omega t - \frac{2\pi}{q}\right]$. $v_q = \sqrt{2}V \sin\left[\omega t - (q-1)\frac{2\pi}{q}\right]$		
	Half-wave	Full-wave	
V_o	$\frac{q}{\pi} \sqrt{2}V \sin \frac{\pi}{q}$	$2 \frac{q}{\pi} \sqrt{2}V \sin \frac{\pi}{q}$	$\frac{q}{\pi} \sqrt{2}V$
Load harmonics	$n=q$	$n=q$ q even $n=2q$ q odd	$n=q$ q even $n=2q$ q odd
\hat{V}_o \check{V}_o	$\sqrt{2}V$ $\sqrt{2}V \cos \frac{\pi}{q}$	$2\sqrt{2}V \cos \frac{\pi}{2q}$	
\hat{V}_{DR}	$\sqrt{2}V$ q even $\sqrt{2}V \cos \frac{\pi}{2q}$ q odd	$2\sqrt{2}V$ q even $2\sqrt{2}V \cos \frac{\pi}{2q}$ q odd	$\frac{\sqrt{2}V}{\sin \frac{\pi}{q}}$ q even $\frac{\sqrt{2}V}{2 \sin \frac{\pi}{2q}}$ q odd
N ^o of diodes	q diodes	$2q$ diodes	$2q$ diodes
\bar{I}_D $I_{D,rms}$	$\bar{I}_D = \frac{I_o}{q}$ $I_{D,rms} = \frac{I_o}{\sqrt{q}}$		
I_s	$I_s = I_o \sqrt{\frac{1}{q}}$	$I_s = I_o \sqrt{\frac{2}{q}}$	$I_s = \frac{1}{2} I_o$ q even $I_s = \frac{1}{2} I_o \frac{\sqrt{q^2 - 1}}{q}$ q odd
$P_o = V_o I_o$ $S = q V_s I_s$ $pf_{load} = \frac{P_o}{S}$	$\frac{\sqrt{2q}}{\pi} \sin \frac{\pi}{q}$	$\frac{2\sqrt{q}}{\pi} \sin \frac{\pi}{q}$	$\frac{2\sqrt{2}}{\pi}$ q even $\frac{2\sqrt{2}}{\pi} \times \frac{q}{\sqrt{q^2 - 1}}$ q odd

The core flux effects of dc currents in 50/60Hz transformers are considered in Chapter 22.

Table 13.5 summarizes the various rectifier characteristics that are independent of the transformer winding configuration.

The transformer for a single-phase two-pulse half-wave rectifier has three windings, a primary and two secondary windings as shown in Chapter 22. Two possible transformer core and winding configurations are shown, namely shell and core. In each case the winding turns ratios are identical, as is the load voltage and current, but the physical transformer limb arrangements are different. The reason for the two possibilities is related to the fact that the circular core can use a single strip of wound cold-rolled grain-orientated silicon steel as lamination material. Such steels offer better magnetic properties than the non-oriented steel that must be used for E core laminations. Single-phase toroidal core transformers are attractive because of the reduced size and weight but manufacturers do not highlight their inherent limitation and susceptibility to dc flux biasing, particularly in half-wave type applications. Although the solution is simple, the advantageous features of the toroidal transformer are lost, as will be shown. For power electronics aspects of 50/60Hz single and 3 phase transformers see Chapter 22.

13.5 Transformer rectifier combinations

Three-phase transformer-rectifier combinations vary depending on the transformer output phase number, their phase shift, and the neutral connection.

13.5.1 Six-phase half wave rectified converters

13.5.1i Six-phase with neutral connection

Figure 13.19 shows two six-phase half-wave rectifiers, which can employ either a star or delta primary. With an RL load, each diode conducts for 60°, and integration over that period gives the average output voltage:

$$V_o = \frac{1}{\frac{1}{3}\pi} \int_{\frac{1}{3}\pi}^{\frac{2}{3}\pi} \sqrt{2}V \sin \omega t \, d\omega t = \frac{3\sqrt{2}V_a}{\pi} = 1.35V_a$$

where the various factors are FF=1.00088, RF=0.042, and PF=0.552.

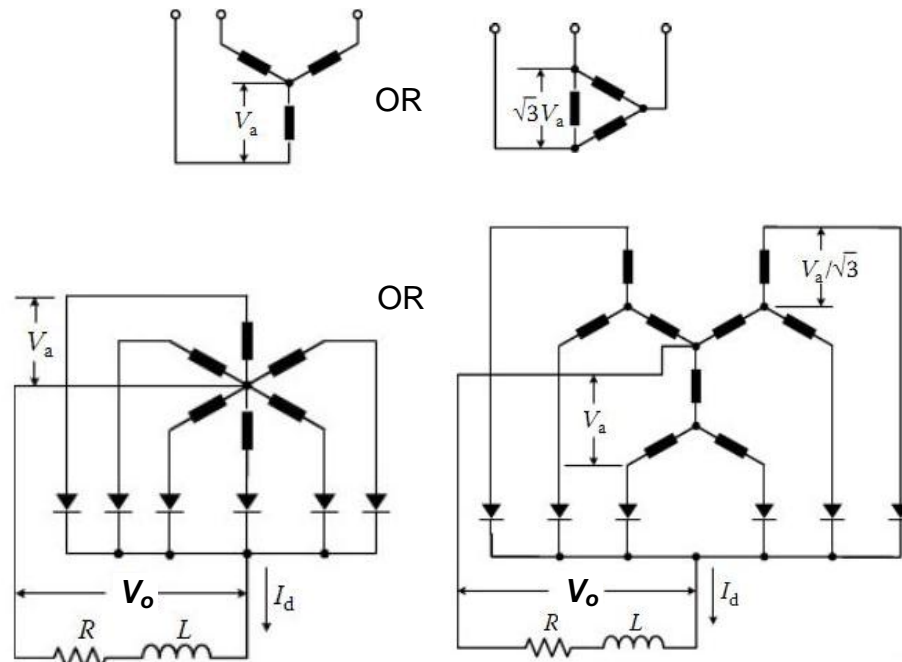

Figure 13.19. Six-phase, half-wave rectifiers, with either a star or delta transformer primary.

13.5.1ii Three-phase double wye with a centre tapped inter-phase transformer.

Figure 13.20 shows a three-phase double wye rectifier with a centre tapped inter-phase transformer, which can employ either a star or delta primary. With an RL load, each diode conducts for 120°, and integration over that period gives the average output voltage:

$$V_o = \frac{1}{\frac{1}{3}\pi} \int_{\frac{\pi}{6}}^{\frac{5\pi}{6}} \sqrt{2}V \sin \omega t \, d\omega t = \frac{3\sqrt{3}\sqrt{2}V_a}{2\pi} = 1.17V_a$$

where the various factors are FF=1.01615, RF=0.18, and PF=0.686.

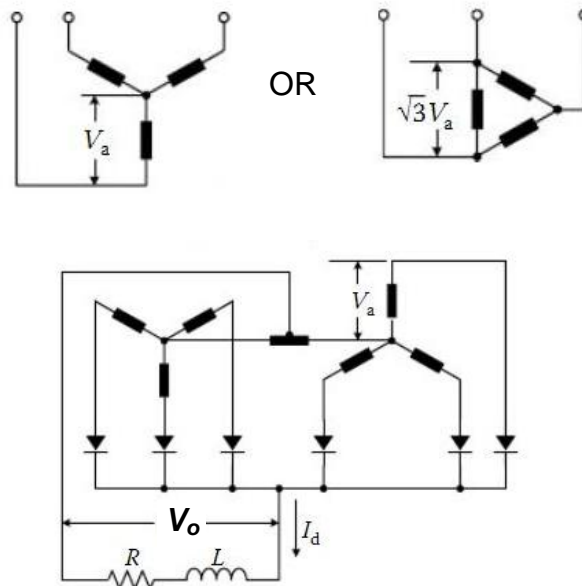

Figure 13.20. Three-phase, double wye rectifier with either a star or delta transformer primary.

13.5.2 Three-phase full-wave rectified converters

Full-wave rectifiers employ six diodes as shown in figure 13.21, each of which conducts for an overlapping 120° period. With an RL load, the average output voltage is

$$V_o = \frac{2}{2/3\pi} \int_{\pi/6}^{5\pi/6} \sqrt{2}V \sin\omega t \, d\omega t = \frac{3\sqrt{3}\sqrt{2}V_a}{\pi} = 2.34V_a$$

where the various factors are FF=1.00088, RF=0.042, and PF=0.956. Circuit current and voltage waveforms are shown in figure 13.14.

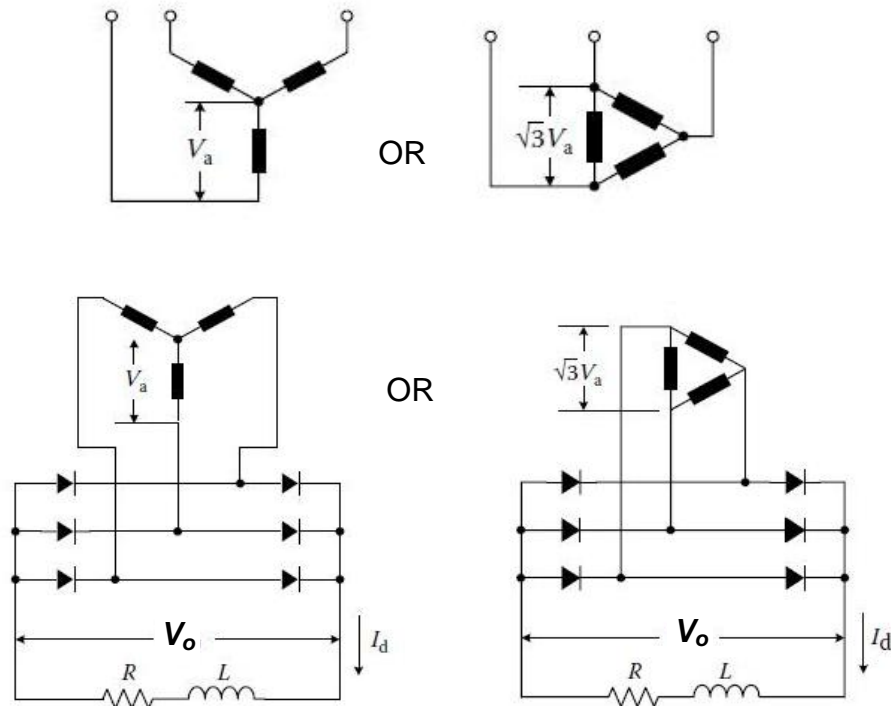

Figure 13.21. Three-phase, full-wave rectifier with either a star or delta transformer primary and secondary.

13.5.3 Multi-phase full-wave rectified converters

The dc output form and ripple factors can be improved by using 12 and higher phase supplies, created by multiple transformer and transformer winding connections, as shown in figure 13.22.

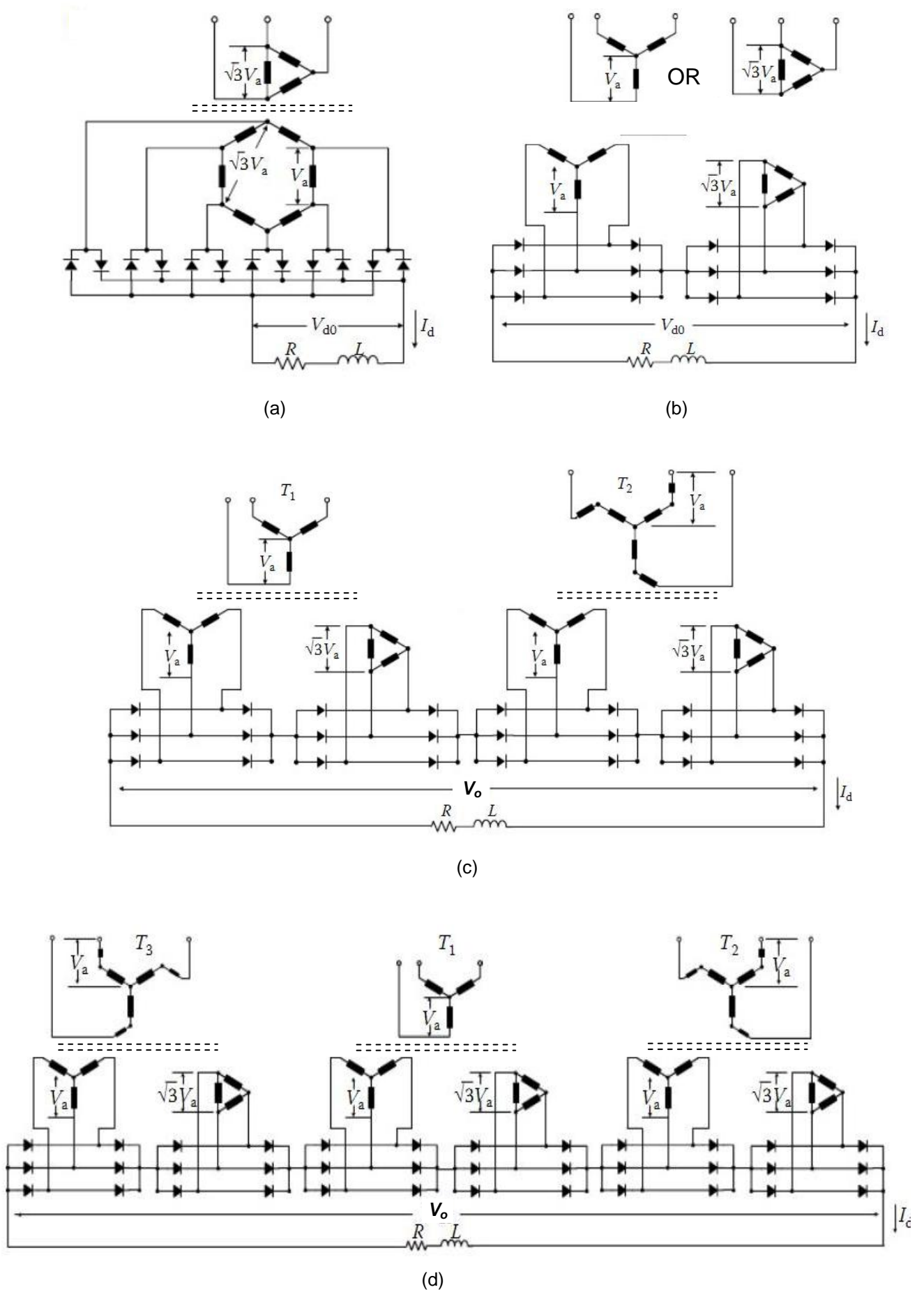

Figure 13.22. Multi-phase, full-wave rectifiers: (a) six phase, (b) series bridges, (c) two transformer cascaded bridges, and (d) three transformer, cascaded bridges.

Figure 13.22a shows a six phase, hexagon connect transformer secondary, where each diode conducts for 60°. The transformer primary can be star or delta connected. The secondary windings can better utilised as two separate windings, as shown in figure 13.22b, where diode conduction increases to 120° and the average output voltage is increased and ripple and form factors are improved.

The average output voltage and ripple and form factor can be improved by using two transformers as in figure 13.22c and three transformers as in figure 13.22d. Ripple cancellation is achieved by phase shifting the transformers, specifically 15° in former 24 pulse case and ±10° in the latter, 36 pulse case. The shift is 360°/pulse number, but the supply power factor is constant and remains high, 0.956 lagging.

Table 13.6. Transformer feed rectifier characteristics

Full-wave rectifier	Number of transformers	Number of three phase bridges	Number of diodes	Diode conduction period	Average output voltage	Form Factor Ripple Factor Power Factor
13.22a	1	2	12	60°	$\frac{2}{\frac{1}{3}\pi} \int_{\frac{1}{3}\pi}^{\frac{2}{3}\pi} \sqrt{2}V \sin \omega t \, d\omega t$ $= \frac{6\sqrt{2}V_a}{\pi}$ $= 2.7V_a$	1.000888 0.042 0.956
13.22b	1	2	12	120°	$\frac{4}{\frac{2}{3}\pi} \int_{\pi/6}^{5\pi/6} \sqrt{2}V \sin \omega t \, d\omega t$ $= \frac{6\sqrt{3}\sqrt{2}V_a}{\pi}$ $= 4.678V_a$	1.0000567 0.0106 0.956
13.22c	2	4	24	120°	$\frac{8}{\frac{2}{3}\pi} \int_{\pi/6}^{5\pi/6} \sqrt{2}V \sin \omega t \, d\omega t$ $= \frac{12\sqrt{3}\sqrt{2}V_a}{\pi}$ $= 9.356V_a$	1.0000036 0.00267 0.956
13.22d	3	6	36	120°	$\frac{12}{\frac{2}{3}\pi} \int_{\pi/6}^{5\pi/6} \sqrt{2}V \sin \omega t \, d\omega t$ $= \frac{18\sqrt{3}\sqrt{2}V_a}{\pi}$ $= 14.035V_a$	1.0000007 0.00119 0.956
13.14 13.21	1	1	6	120°	$\frac{2}{\frac{2}{3}\pi} \int_{\pi/6}^{5\pi/6} \sqrt{2}V \sin \omega t \, d\omega t$ $= \frac{3\sqrt{3}\sqrt{2}V_a}{\pi}$ $= 2.34V_a$	1.00088 0.042 0.956
13.12	1	½	3	120°	$\frac{1}{\frac{2}{3}\pi} \int_{\pi/6}^{5\pi/6} \sqrt{2}V \sin \omega t \, d\omega t$ $= \sqrt{2}V \frac{1/2\sqrt{3}}{\pi/3}$ $= 1.17 \times V$	1.016 0.18 0.686

13.6 Voltage multipliers

Voltage multipliers are ac to dc power conversion circuits, comprised of diodes and capacitors that are interconnected so as to produce a high potential dc voltage from a lower voltage ac source. As in figure 13.23a, multipliers are comprised of cascaded stages each comprised of a diode and a capacitor.

Voltage multipliers are a simple way to generate high voltages at relatively low currents. By using only capacitors and diodes, the voltage multipliers can step up relatively low voltages to extremely high values, while at the same time being far lighter and cheaper than transformers. The advantage of the circuit is that the voltage across each cascaded stage is only equal to twice the peak input voltage, so it requires relatively low cost components and is easy to insulate. An output can also be tapped from any stage, like a multi-tapped transformer.

The voltage multiplier has poor voltage regulation, that is, the voltage drops rapidly as a function the output current, as in figure 13.23b. The output I - V characteristic is approximately hyperbolic, so it is suitable for charging capacitor banks to high voltages at near constant charging power. Furthermore, the ripple on the output, particularly at high loads, is high. The output voltage is not isolated from the input voltage source, although transformer coupling provides general isolation.

The most commonly used multiplier circuit is the half-wave series multiplier. Other multiplier circuits can be derived from its operating principles.

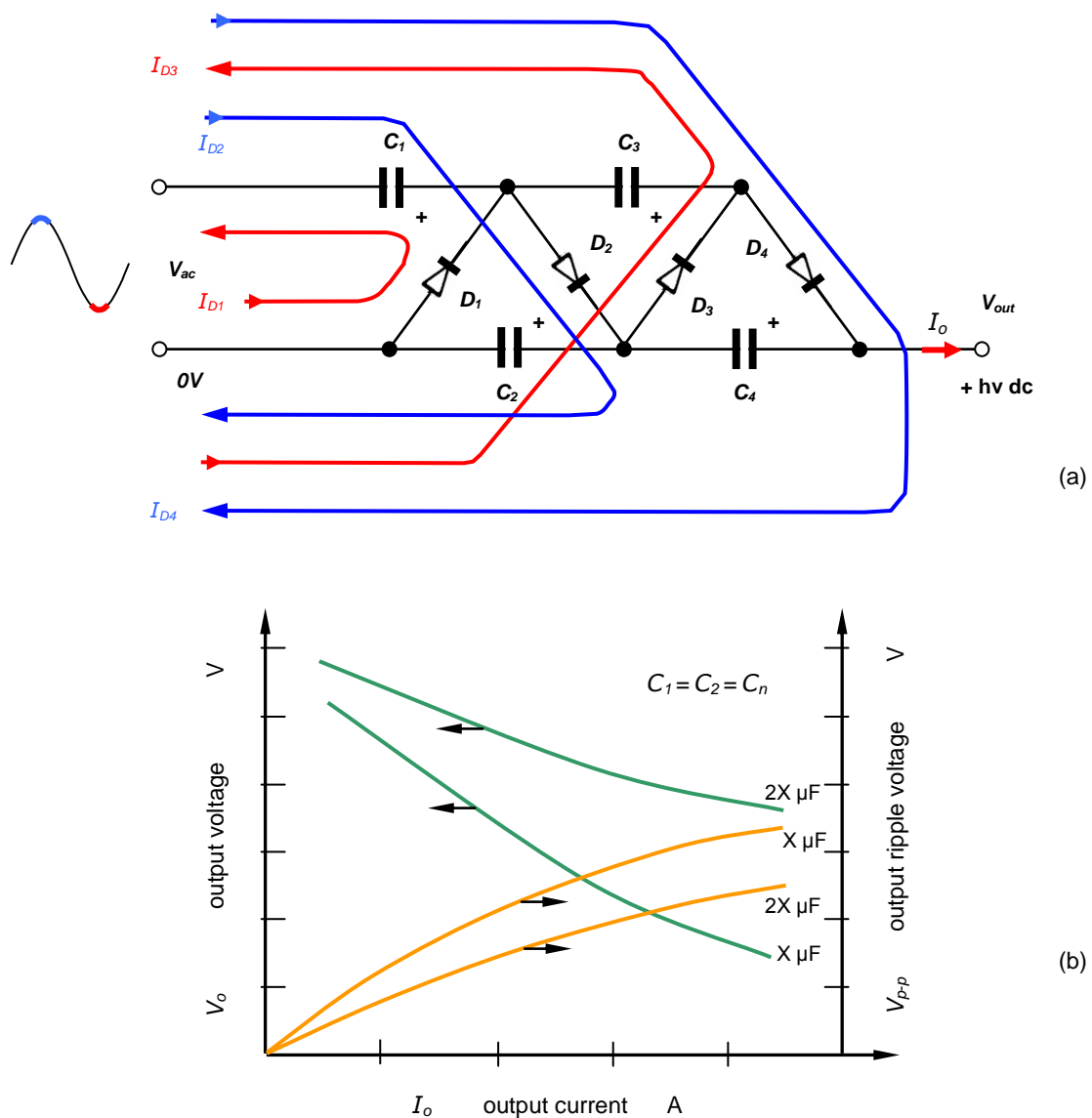

Figure 13.23. Charging sequence of a half-wave series positive output voltage multiplier and output characteristics dependence on output current and stage capacitance.

The following description for a two-stage series voltage multiplier assumes no losses and represents sequential reversals of polarity of the source transformer T_s in the figure 13.23a. The number of stages is equal to the number of smoothing capacitors between ground and V_{out} , which in this case is two, capacitors C_2 and C_4 .

- V_{ac} = Negative Peak: C_1 charges through D_1 to V_{pk} by current I_{D1}
- V_{ac} = Positive Peak: V_{pk} of Ts adds arithmetically to existing potential C_1 , thus C_2 charges to $2 V_{pk}$ thru D_2 by current I_{D2}
- V_{ac} = Negative Peak: C_3 is charged to $2 V_{pk}$ through D_3 by current I_{D3}
- V_{ac} = Positive Peak: C_4 is charged to $2 V_{pk}$ by current I_{D4} through D_4 then V_{pk} .

For N stages (series capacitors) the output voltage is $N \times V_{pk}$.

13.6.1 Half-wave series multipliers

The capacitors are in series, so effectively capacitance is as for series connected capacitors, C/N , but voltage rating is the cumulative sum of the series capacitors between the output terminals. This multiplier is the most common, and is versatile, being used in high-voltage, low-current applications. The basic charging sequence in figure 13.24 is as for the circuit shown in figure 13.23a, where the diodes conduct in the order D_1 to D_4 , for both output polarity versions.

Half-wave series voltage multiplier features include:

- a wide range of multiplication stages
- low cost
- uniform stress per stage on diodes and capacitors, $2 V_{pk}$ and V_{pk}

Any one capacitor can be eliminated from the capacitor filter bank if the load is capacitive. Whether full wave or half-wave, the series diodes prevent the output voltage from swinging negative. At high discharges, part of the output current is also drawn via a diode, hampering rapid high current discharge.

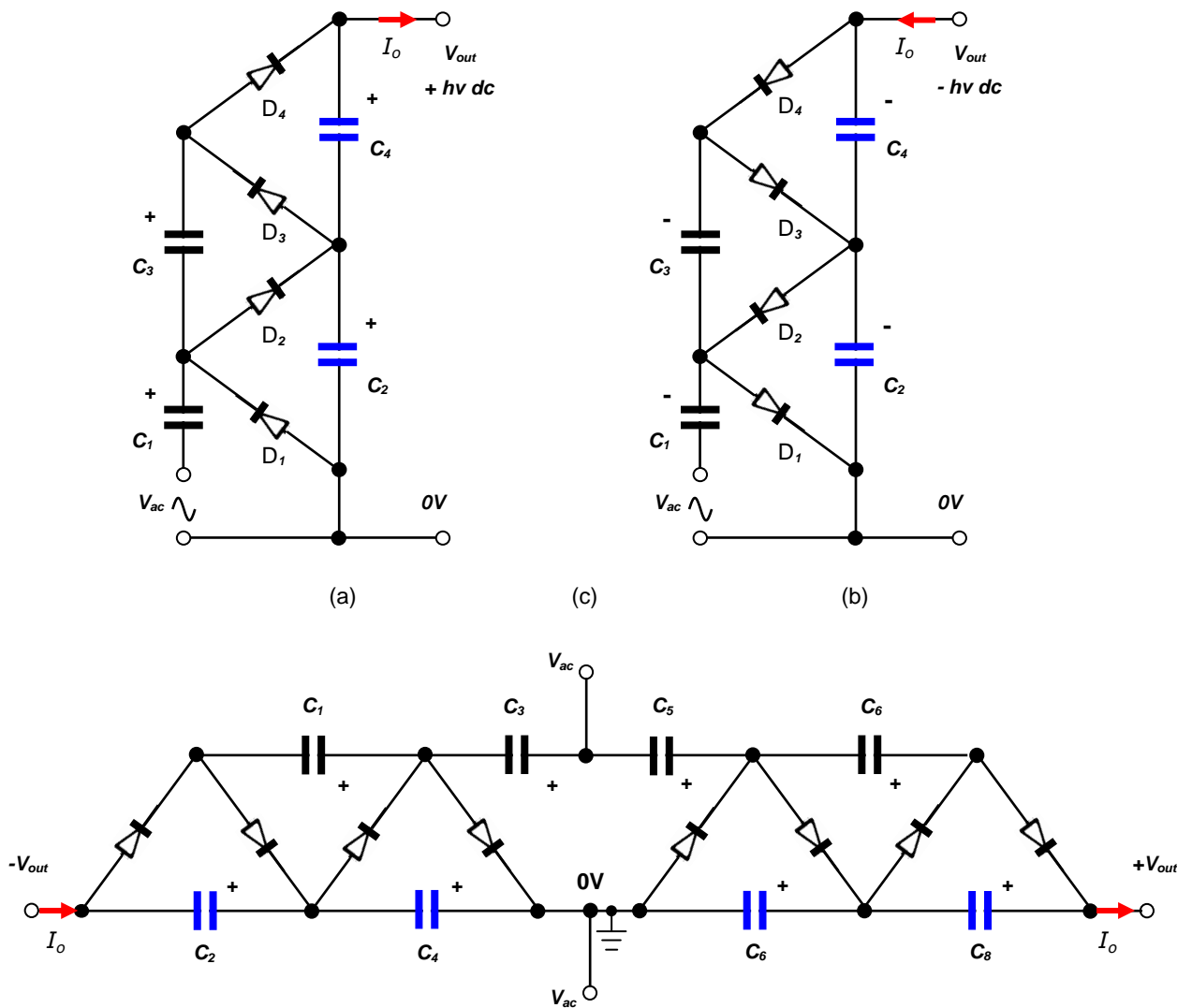

Figure 13.24. Series half-wave voltage multipliers: (a) two stage positive hv output voltage; (b) two stage negative hv output voltage; and (c) four stage multiplier configured with \pm output hv voltage.

Dual polarity output voltage is produced by connecting positive and negative multipliers as shown in the four stage circuit is shown in figure 13.24c, where an unlimited stage number can be cascaded. Since regulation is proportional to N^3 , a large number of stages eventually becomes ineffective. A centre tapped capacitor string connection reduces the maximum voltage potential with respect to ground. An odd number of stages can be produced as well as an even number of stages. The output voltage may be tapped at any point on the capacitor series filter bank.

Once a load is connected at the output, the output voltage decreases due to the voltage regulation. Also, any small fluctuation of load impedance causes a large fluctuation in the multiplier output voltage due to the number of stages involved. For this reason, voltage multipliers are used only in special applications where the load is constant and has a high impedance or where voltage stability is not critical.

Half-wave Output Voltage

The open-circuit output voltage $V_{o/c}$ of each stage is nominally twice the peak input voltage V_{pk} . Assuming the ac input voltage and frequency are constant, for N cascaded stages, the output voltage is

$$V_{o/c} = 2N \times V_{pk} \quad (13.132)$$

In practice, several cycles are required to reach full output voltage. The output voltage follows an RC network exponential curve, where R is the output impedance of the ac source, whilst C is the effective dynamic capacitance of the voltage multiplier, $N \times C$. This charging occurs only upon switch-on of the voltage multiplier from a discharged state, and does not repeat itself unless the output is short circuited. The most common input ac waveforms are sine waves and square waves.

Output Voltage Regulation

DC output voltage drops as the dc output current increases, as shown in figure 13.23b. Regulation is the drop in dc output voltage from the ideal at a specified dc output current (assuming the ac input voltage and input frequency are constant). The voltage drop under load is mostly reactive and is calculated as:

$$V_{reg} = I_o \times \frac{4N^3 + 3N^2 - N}{6f \times C} = I_o \times \frac{4N^2 + 3N^2 - 1}{6f \times C/N} \quad (13.133)$$

where:

I_o is the load or output dc current (A)

C is the stage capacitance (F)

f is the ac frequency (Hz)

N is the number of stages

C/N is the effective output capacitance (F).

Regulation voltage droop is not a power loss in a multiplier. Power losses are primarily diode forward conduction and rarely result in excessive multiplier temperatures at the low current loadings.

Substituting V_{reg} from equation (13.133):

$$V_{out} = V_{o/c} - V_{reg} = 2NV_{pk} - I_o \times \frac{4N^3 + 3N^2 - N}{6f \times C} \quad (13.134)$$

Output Voltage Ripple

Ripple voltage is the magnitude of fluctuation in dc output voltage at a specific output current. This assumes the ac input voltage and frequency are maintained constant. The ripple voltage in the case where all stage capacitances, C_1 through C_{2N} , are equal, is:

$$V_{ripple} = I_o \times \frac{N^2 + N}{2f \times C} \quad (13.135)$$

The ripple grows rapidly as the number of stages increases, with N squared. A common modification to the design is to make the stage capacitances larger at the input, with $C_1 = C_2 = N \times C$, $C_3 = C_4 = (N-1) \times C$, and so forth. Then the ripple is:

$$V_{ripple} = \frac{I_o}{f \times C} \quad (13.136)$$

For a large number of stages, $N \geq 5$, the N^3 term in the voltage drop equation dominates. Differentiating the V_{out} equation without the negligible terms, with respect to the number of stages and equating to zero, gives an equation for the optimum (integer) number of stages N_{opt} for the equal valued capacitor design:

$$\frac{dV_{out}}{dN} = \frac{d}{dN} \left(2NV_{pk} - \frac{I_o}{6f \times C} \times 4N^3 \right) = 0$$

$$N_{opt} = \text{int} \left[\left(\frac{V_{pk} f \times C}{I_o} \right)^{1/2} \right] \quad (13.137)$$

Increasing the frequency can dramatically reduce the ripple, and the voltage drop under load, which accounts for the popularity of driving a multiplier stack with a switching power supply.

If the driving voltage V_{pk} and the required output voltage $V_{o/c}$ are known, the optimum number of cascaded stages is:

$$N_{opt} = \text{int} \left[\frac{3V_{out}}{4V_{pk}} \right] \quad (13.138)$$

13.6.2 Half-wave parallel multipliers

Opposite polarity half-wave parallel voltage multipliers are shown in figure 13.24. The output capacitors share a common connection but must have a high voltage rating. The output is usually low voltage but with high currents. The basic charging sequence in figure 13.25 is the same as shown in figure 13.23, where the diodes conduct in the order D_1 to D_4 , for both output polarity versions.

Parallel multipliers offer the following features:

- uniform stress on diodes
- compact
- voltage stress on capacitors increases with successive stages by V_{pk}
- highly efficient

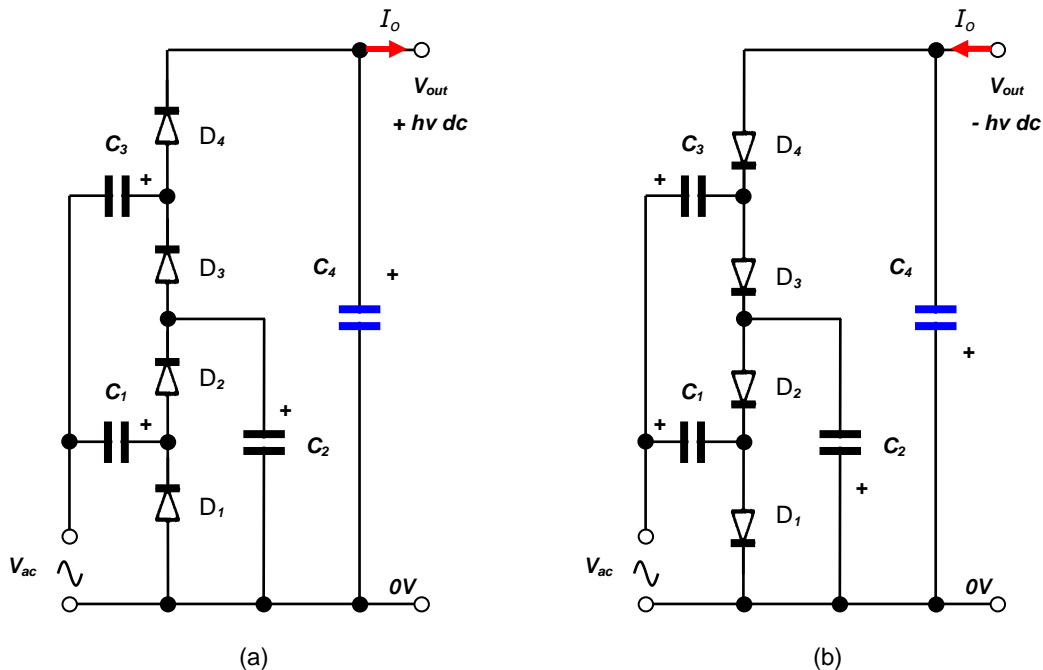

Figure 13.25. Parallel half-wave voltage multipliers: (a) two stage positive $h\nu$ output voltage and (b) two stage negative $h\nu$ output voltage.

13.6.3 Full-wave series multipliers

Increasing the frequency can dramatically reduce the ripple, and the voltage drop under load, which can be achieved by driving a multiplier stack with a switched mode power supply.

Figure 13.26 shows a typical full-wave two-stage series voltage multiplier. It is comprised of two anti-phase ac input half-wave multipliers sharing a common series output capacitor string. This effectively doubles the number of charging cycles per second, and thus reduces the voltage drop and ripple factor. The input is usually fed from a centre-tapped ac transformer or MOSFET H-bridge circuit.

The full-wave series voltage multiplier has the following general features:

- uniform stress on components
- highly efficient
- high voltage
- high power capability
- easy to produce
- increased voltage stress on capacitors with successive stages
- wide range of multiplication stages

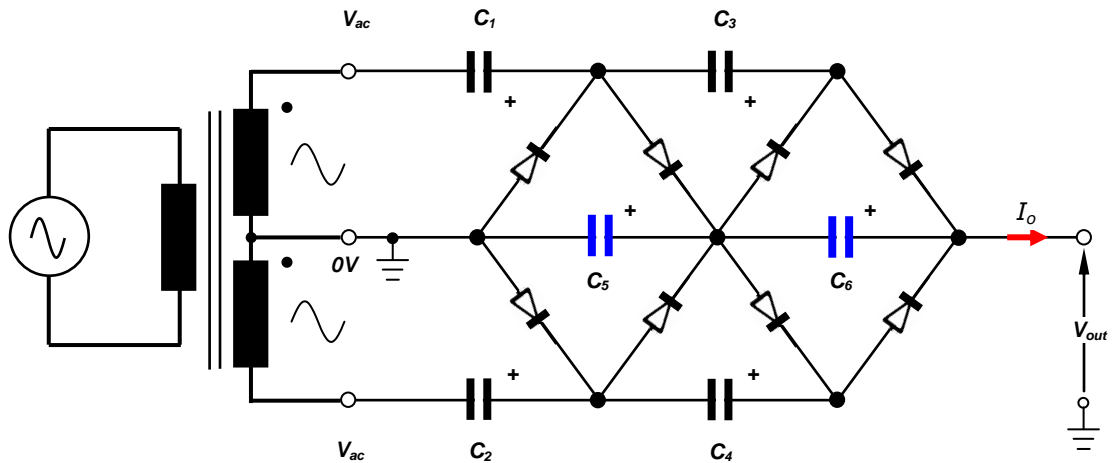

Figure 13.26. Two-stage series full-wave voltage multiplier.

Full-wave Output Voltage

As with the half-wave voltage multiplier, the full-wave voltage multiplier output voltage is given by:

$$V_{o/c} = 2NV_{pk} \quad (13.139)$$

Output Voltage Regulation

DC output voltage decreases as dc output current increases. Regulation is the drop in dc output voltage from the ideal at a specified dc output current, assuming constant ac input voltage and frequency. The voltage drop under load is mostly reactive and is:

$$V_{reg} = I_o \times \frac{N^3 + 2N}{6f \times C} = I_o \times \frac{N^2 + 2}{6f \times C/N} \quad (13.140)$$

where:

I_o is the load or output dc current (A)

C is the stage capacitance (F)

f is the ac frequency (Hz)

N is the number of stages

C/N is the effective output capacitance (F).

Regulation voltage droop is not a power loss in a multiplier. Power losses are primarily diode forward conduction and rarely result in excessive multiplier temperatures at the low current loadings. Substituting equation (13.140) for V_{reg} :

$$V_{out} = V_{o/c} - V_{reg} = 2N \times V_{pk} - I_o \times \frac{N^3 + 2N}{6f \times C} \quad (13.141)$$

Output Voltage Ripple

The ripple voltage, in the case where all stage capacitances are equal, is given by:

$$V_{ripple} = I_o \times \frac{N}{2f \times C} \quad (13.142)$$

If the driving voltage V_{pk} and the required output voltage $V_{o/c}$ are known, the optimum number of cascaded stages is:

$$N_{opt} = \text{int} \left[\frac{0.521V_{out}}{V_{pk}} \right] \quad (13.143)$$

Example 13.9: Half-wave voltage multiplier

A three-stage half-wave series voltage multiplier, is driven by a 50kHz peak voltage of 10kV, with 1nF capacitances, and a load current of 10mA.

- Calculate the open circuit output voltage, regulated output voltage, ripple voltage, and optimal number of stages for the required voltage transfer function.
- What is the capacitance and voltage rating of each stage of a parallel connected multiplier?
- What is the output ripple if progressively smaller capacitance is used?

Solution

- i. In a three-stage voltage multiplier, the no load voltage $V_{o/c} = 2 \times N \times V_{pk} = 2 \times 3 \times 10\text{kV} = 60\text{kV}$

$$V_{reg} = I_o \frac{4N^3 + 3N^2 - N}{6f \times C} = 10\text{mA} \times \frac{3^3 + 3 \times 3^2 - 3}{6 \times 50\text{kHz} \times 1\text{nF}} = 1.7\text{kV}$$

$$V_{out} = 60\text{kV} - 1.7\text{kV} = 58.3\text{kV}$$

So the output voltage will swing between 60kV and 58.3kV, depending on the load current.

The output ripple voltage is

$$V_{ripple} = I_o \frac{N^2 + N}{2f \times C} = 10\text{mA} \frac{3^2 + 3}{2 \times 50\text{kHz} \times 1\text{nF}} = 3\text{kV}$$

The optimal number of stages, from equation (13.143), is

$$N_{opt} = \text{int} \left[\frac{0.521 \times V_{out}}{V_{pk}} \right] = \text{int} \left[\frac{0.521 \times 58.3\text{kV}}{10\text{kV}} \right] = 3$$

- ii. An equivalent parallel multiplier would require each capacitor stage to equal the total series capacitance of the series capacitor bank.

In this case, the three capacitors in the dc bank would equal 1000pF/3 or 330pF. The parallel equivalent would require 330pF capacitors in each stage. However, each successive stage, from the input, would require a higher voltage capacitor, 20kV, 40kV and 60kV, respectively.

- iii. When $C_1 = C_2 = N \times C = 3\text{nF}$, $C_3 = C_4 = (N-1) \times C = 2\text{nF}$, $C_5 = C_6 = (N-2) \times C = 1\text{nF}$.

$$V_{ripple} = \frac{I_o}{f \times C} = \frac{10\text{mA}}{50\text{kHz} \times 1\text{nF}} = 200\text{V}$$

This modification reduces the ripple voltage from 3kV to just 200V.

**Example 13.10: Full-wave voltage multiplier**

A three-stage full-wave parallel voltage multiplier, is driven by a 50kHz peak voltage of 10kV, with 1nF capacitances, and a load current of 10mA. Calculate the output voltage and ripple voltage.

Solution

In a three-stage voltage multiplier, the no load voltage $V_{o/c} = 2 \times N \times V_{pk} = 2 \times 3 \times 10\text{kV} = 60\text{kV}$.

$$V_{reg} = I_o \frac{N^3 + 2N}{6f \times C} = 10\text{mA} \frac{3^3 + 2 \times 3}{6 \times 50\text{kHz} \times 1\text{nF}} = 1.1\text{kV}$$

Full-wave rectification reduces the regulation voltage drop from 1.7kV in example 13.9, to 1.1kV. The output voltage is increased by 600V, from 58.3kV in example 13.9, to $V_{out} = 60\text{kV} - 1.1\text{kV} = 58.9\text{kV}$.

The ripple voltage reduces from 3kV for half-wave multiplication in example 13.9, to

$$V_{ripple} = I_o \frac{N}{2f \times C} = 10\text{mA} \frac{3}{2 \times 50\text{kHz} \times 1\text{nF}} = 200\text{V}$$

**13.6.4 Three-phase voltage multipliers**

The full-wave multiplier in figure 13.27 is a special case of a poly-phase (0° and 180°) multiplier where more than one multiplier share a common series stack of load capacitors. In figure 13.27, the phase angle between phases is 0° , 120° , and 240° , respectively. The peak voltage supplied by each secondary winding is V_{pk} .

The three-phase circuit in figure 13.27b can be modified by disconnecting the centre point of the Y configuration from ground and omitting the first capacitor in each charging stack, as shown in figure 13.27c. As a result, the open-circuit dc voltage per stage is reduced from $2 \times V_{pk}$ to $\sqrt{3} \times V_{pk}$. The output impedance, however, decreases dramatically, so the output voltage under load may be even higher, depending on the load current. Therefore, this variant is preferred if the multiplier has to supply higher currents.

13.6.5 Series versus parallel voltage multipliers

The theory of operation is the same for both series and parallel connected voltage multipliers. Parallel multipliers require less capacitance per cascaded stage than their series counterparts, however parallel multipliers require higher capacitor voltage ratings on successive cascaded stages. The parallel multiplier output is easier to RC filter in applications requiring low output ripple voltage.

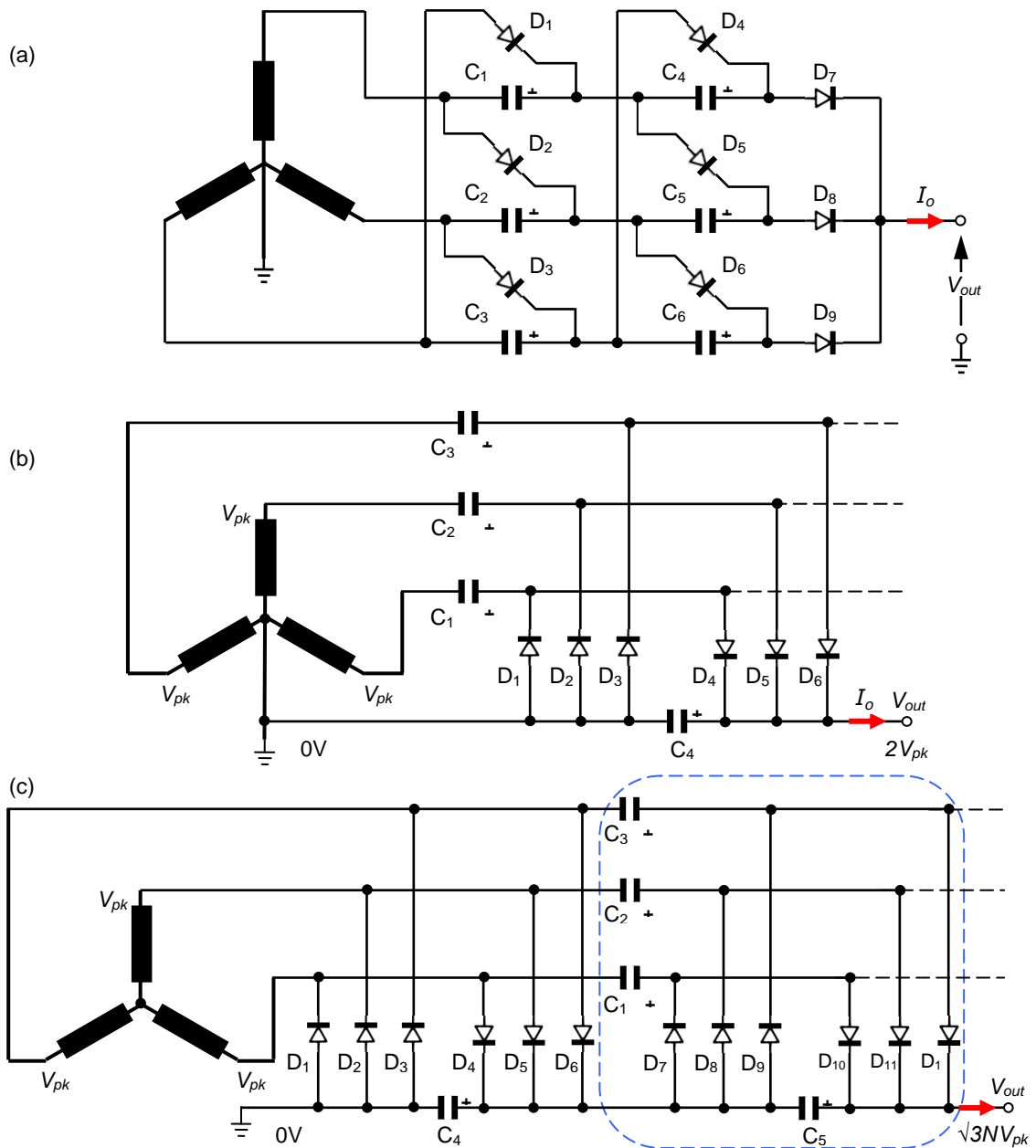

Figure 13.27. Three-phase Y configuration voltage multipliers: (a) series diode output stage; (b) grounded centre point; and (c) floating centre point.

13.7 Marx voltage generator

The Marx generator shown in figure 13.28, charges the energy storage capacitor of each stage in parallel with a relatively low voltage (1kV to 6kV), and then discharges them by means of active switches in series, into the load. The output voltage is then equal to the charging voltage multiplied by the number of stages. The series inductance of this type of generators is low, as a result the rise time and fall time of the output pulses can be less than $1\mu\text{s}$. The pulse repetition rate can be more than 20kHz for short pulses, and the pulse length can be several ms.

The spark gaps in the tradition approach in figure 13.28a can be replaced by IGBTs, as in figure 13.28b, for pulses duration greater than about $1\mu\text{s}$. Switches P are turned on simultaneously to parallel charge all the cell capacitors, and pulse discharge is produced by switching on switches S (all switches P remain off). Pulse shaping is possible by controlling the on/off of switches S. An inactive cell (S off) is bypassed by diode D, whence the voltage across the off switch S is clamped to the cell capacitor voltage. Pulse length, magnitude, and shape can be controlled by switches S, provide the charged delivered to the load from the capacitors decreases for cells progressive further from the charging source V_s (unless the cells are fully discharged into the load after each pulse). Cell capacitor charging efficiency through resistor R_c can be improved by using smps techniques, which would allow adjustable cell capacitor voltage levels.

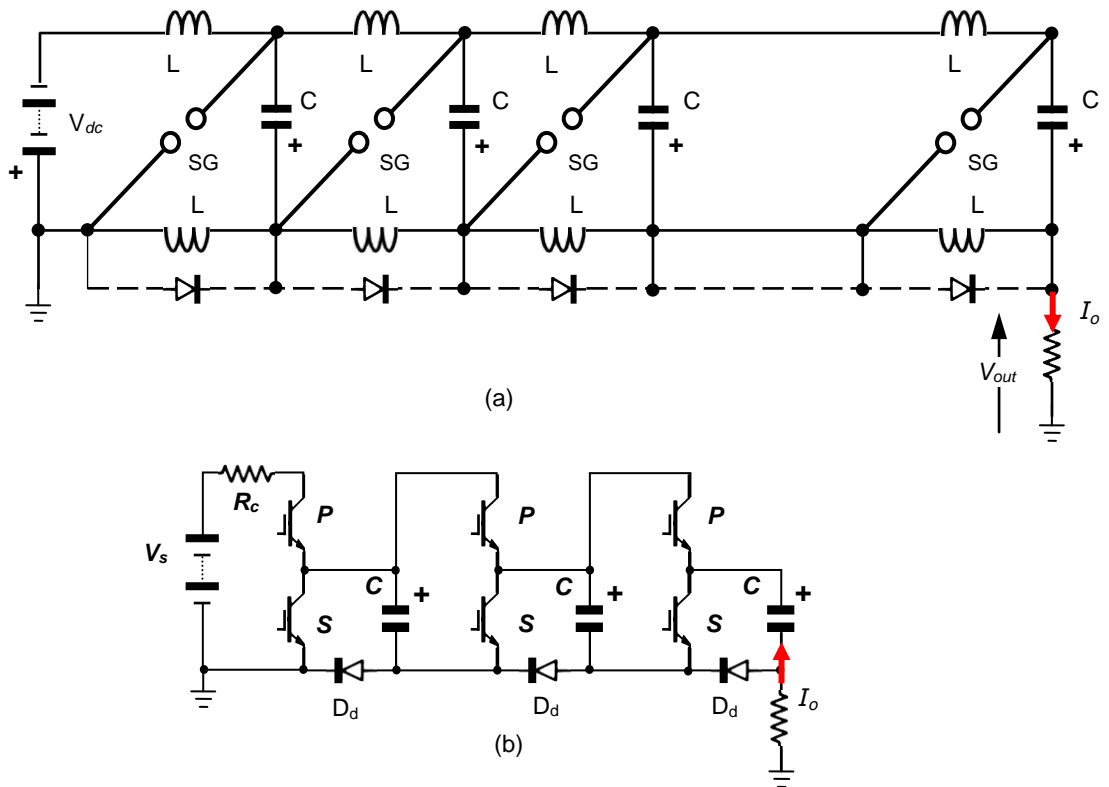

Figure 13.28. The hv Marx pulse generators: (a) spark gap version and (b) semiconductor version.

Figure 13.29 shows semiconductor Marx generators based on HVDC MMC concepts, with a buck-boost converter for parallel capacitor charging. The dc converter offer soft start and an extra degree of output freedom by offering adjustable output voltage, hence cell capacitor voltages. The unipolar pulse generator in figure 13.29a requires an extra diode per cell and a switch T_p , (rated at the buck boost converter output voltage $\delta/1 - \delta V_s$) to isolated the load during capacitor parallel charging. It offers better directing-diode D_d voltage clamping than in figure 13.28b, since diode clamping is passive, through a diode as opposed to through switch S in figure 13.28b. Figure 13.29a can be extending to a bipolar voltage output topology by using full bridge cells, as shown in figure 13.29b, thereby avoiding using two unipolar generators, back to back.

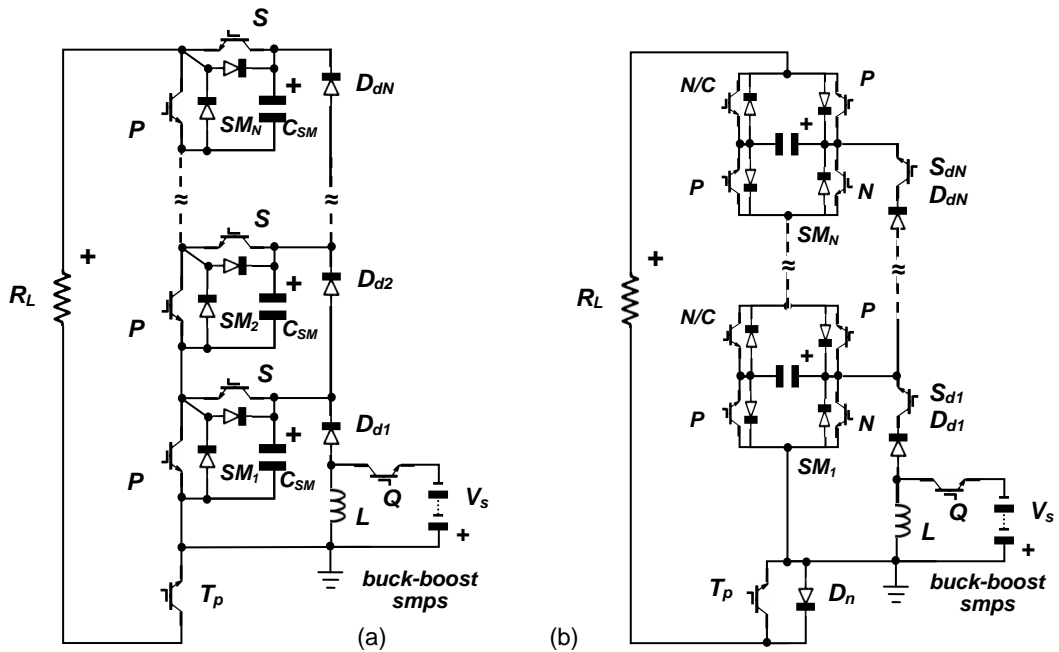

Figure 13.29. Semiconductor hv Marx generators: (a) unipolar output and (b) bipolar output.

In figure 13.29b, switches P are turned on for positive output voltages and switches N and N/C for negatives voltages. Cell capacitors are charged by simultaneously turning on N/C and S_d . Switches S_d prevent cell capacitor discharge during negative outputs, through a path created involving adjacent cells. In both topologies in Figure 13.29, for controlled cell capacitor charging (to avoid uncontrolled in rush current between cells) pulse generation should ensure cells further from the smps deliver less charge than cell closer to the dc converter.

In low power electronics, the Marx concept is used to increase a low voltage, and is more meaningfully termed a switched capacitor converter.

13.8 Definitions

$$v(\omega t) = \sum_{n=0}^{\infty} \sqrt{2} V_n \sin(n\omega t - \phi_n) \quad i(\omega t) = \sum_{n=0}^{\infty} \sqrt{2} I_n \sin(n\omega t - \phi_n)$$

$$\text{total current} \quad I_s^2 = I_1^2 + I_2^2 + I_3^2 + \dots I_n^2 \quad \text{distortion current harmonic current} \quad I_{dis}^2 = I_2^2 + I_3^2 + \dots I_n^2$$

$$\begin{array}{l} \text{total} \\ \text{harmonic factor} \\ \text{distortion factor} \end{array} \quad DF = k = \frac{I_{dis}}{I_s}$$

$$\text{total harmonic distortion} \quad THD = \frac{I_{dis}}{I_1}$$

$$\text{displacement power factor} \quad DPF = \cos \phi_1 = \lambda_1$$

$$\text{circuit power factor} \quad pf = \lambda = \frac{\text{active input power}}{V_s I_s}$$

$$= \frac{\cos \phi_1}{\sqrt{1 + THD^2}}$$

$$\text{crest factor} \quad cf = \frac{\hat{I}_s}{I_s}$$

$$\text{form factor} = \frac{\text{rms value}}{\text{average value}}$$

The average (or mean or dc) rms (or effective) values, respectively, of a waveform, are defined by

$$V_o = \frac{1}{T} \int_0^T v_o(t) dt$$

and

$$V_{rms} = \sqrt{\frac{1}{T} \int_0^T v_o^2(t) dt}$$

$$\begin{array}{ll} V_o & \text{average output voltage} \\ V_{rms} & \text{rms output voltage} \\ \hat{V} & \text{peak output voltage} \end{array} \quad \begin{array}{ll} \bar{I}_o & \text{average output current} \\ I_{rms} & \text{rms output current} \\ \hat{I} & \text{peak output current} \end{array}$$

$$\begin{array}{ll} \text{Load voltage form factor} = FF_v = \frac{V_{rms}}{V_o} & \text{Load voltage crest factor} = CF_v = \frac{\hat{V}}{V_{rms}} \\ \text{Load current form factor} = FF_i = \frac{I_{rms}}{\bar{I}_o} & \text{Load current crest factor} = CF_i = \frac{\hat{I}}{I_{rms}} \end{array}$$

$$\begin{aligned} \text{Waveform smoothness} = \text{Ripple factor} = RF_v &= \frac{\text{effective values of ac } V \text{ (or } I)}{\text{average value of } V \text{ (or } I)} = \frac{V_{Ri}}{V_o} \\ &= \sqrt{\frac{V_{rms}^2 - V_o^2}{V_o^2}} = \sqrt{FF_v^2 - 1} \end{aligned}$$

$$\text{where} \quad V_{Ri} = \left[\sum_{n=1}^{\infty} \frac{1}{2} (v_{an}^2 + v_{bn}^2) \right]^{1/2}$$

$$\begin{aligned} \text{similarly the current ripple factor is } RF_i &= \frac{I_{Ri}}{\bar{I}_o} = \sqrt{FF_i^2 - 1} \\ RF_i &= RF_v \text{ for a resistive load} \end{aligned}$$

$$\begin{aligned} \text{Rectification efficiency} = \eta &= \frac{\text{dc load power}}{\text{ac load power} + \text{rectifier losses}} \\ &= \frac{V_o I_o}{V_{rms} I_{rms} + \text{Loss}_{\text{rectifier}}} \end{aligned}$$

Waveform fundamental and harmonic rms components are define by

$$V_1 = \sqrt{1/2(V_{1a}^2 + V_{1b}^2)}$$

where

$$V_{1a} = \frac{2}{T} \int_0^T v(t) \cos 2\pi t/T dt \quad V_{1b} = \frac{2}{T} \int_0^T v(t) \sin 2\pi t/T dt$$

and for the k^{th} harmonic component

$$V_k = \sqrt{1/2(V_{ka}^2 + V_{kb}^2)}$$

where

$$V_{ka} = \frac{2}{T} \int_0^T v(t) \cos 2\pi kt/T dt \quad V_{kb} = \frac{2}{T} \int_0^T v(t) \sin 2\pi kt/T dt$$

Distortion factor is defined as

$$DF_v = \frac{V_1}{V_{rms}}$$

The total harmonic distortion is

$$THD_v = \sqrt{\sum_{\substack{k=0 \\ k \neq 1}}^{\infty} \left(\frac{V_k}{V_1}\right)^2} = \frac{\sqrt{1 - DF_v^2}}{DF_v}$$

13.9 Output pulse number

Output pulse number p is the number of pulses in the output voltage that occur during one ac input cycle, of frequency f_s . The pulse number p therefore specifies the output harmonics, which occur at $px f_s$, and multiples of that frequency, $m \times p \times f_s$, for $m = 1, 2, 3, \dots$

$$p = \frac{\text{period of input supply voltage}}{\text{period of minimum order harmonic in the output } V \text{ or } I \text{ waveform}}$$

The pulse number p is specified in terms of

- q the number of elements in the commutation group
- r the number of parallel connected commutation groups
- s the number of series connected (phase displaced) commutating groups

Parallel connected commutation groups, r , are usually associated with (and identified by) intergroup reactors (to reduce circulating current), with transformers where at least one secondary is effectively star connected while another is delta connected. The rectified output voltages associated with each transformer secondary, are connected in parallel.

Series connected commutation groups, s , are usually associated with (and identified by) transformers where at least one secondary is effectively star while another is delta connected, with the rectified output associated with each transformer secondary, connected in series.

$$\begin{aligned} q=3 \quad r=2 \quad s=2 \\ p=q \times r \times s \\ p=12 \end{aligned}$$

The mean rectifier output voltage V_o can be specified by

$$V_o = s \frac{q}{\pi} \sqrt{2} V_\phi \times \sin \frac{\pi}{q} \quad (13.144)$$

For a full-wave, single-phase rectifier, $r = 1$, $q = 2$, and $s = 1$, whence $p = 2$

$$V_o = 1 \times \frac{2}{\pi} \sqrt{2} V_\phi \times \sin \frac{\pi}{2} = \frac{2\sqrt{2} V_\phi}{\pi}$$

For a full-wave, three-phase rectifier, $r = 1$, $q = 3$, and $s = 2$, whence $p = 6$

$$V_o = 2 \times \frac{3}{\pi} \sqrt{2} V_\phi \times \sin \frac{\pi}{3} = \frac{3\sqrt{2} V_\phi}{\pi}$$

13.10 AC-dc converter generalised equations

Alternating sinusoidal voltages

$$\begin{aligned} V_1 &= \sqrt{2} V \sin \omega t \\ V_2 &= \sqrt{2} V \sin \left(\omega t - \frac{2\pi}{q} \right) \\ &\vdots \\ V_q &= \sqrt{2} V \sin \left(\omega t - (q-1) \frac{2\pi}{q} \right) \end{aligned}$$

where q is the number of phases (number of voltage sources)

On the secondary or converter side of any transformer, if the load current is assumed constant I_o then the power factor is determined by the load voltage harmonics.

Voltage form factor

$$FF_v = \frac{V_{rms}}{V_o}$$

whence the voltage ripple factor is

$$RF_v = \frac{1}{V_o} [V_{rms}^2 - V_o^2]^{1/2} = [FF_v^2 - 1]^{1/2}$$

The power factor on the secondary side of any transformer is related to the voltage ripple factor by

$$pf = \frac{P_d}{S} = \frac{V_o I_o}{q V I_{rms}} = \frac{1}{\sqrt{RF_v^2 + 1}}$$

On the primary side of a transformer the power factor is related to the secondary power factor, but since the supply is assumed sinusoidal, the power factor is related to the primary current harmonics.

Relationship between current ripple factor and power factor

$$\begin{aligned} RF_i &= \frac{1}{I_1} \sqrt{\sum_{h=3}^{\infty} I_h^2} = \frac{1}{I_1} \sqrt{I_{rms}^2 - I_1^2} \\ pf &= \frac{I_1}{I_{rms}} = \frac{1}{\sqrt{RF_i^2 + 1}} \end{aligned}$$

The supply power factor is related to the primary power factor and is dependent of the supply connection, star or delta, etc.

Half-wave diode rectifiers [see figures 13.2, 13.12]

Pulse number $p=q$. Pulse number is the number of sine crests in the output voltage during one input voltage cycle. There are q phases and q diodes and each diode conducts for $2\pi/q$, with q crest (pulses) in the output voltage

Mean voltage

$$\begin{aligned} V_o &= \frac{q}{2\pi} \int_{\frac{1}{2}\pi - \frac{\pi}{q}}^{\frac{1}{2}\pi + \frac{\pi}{q}} \sqrt{2} V \sin \omega t \, d\omega t \\ &= \frac{q}{\pi} \sqrt{2} V \sin \frac{\pi}{q} \end{aligned}$$

RMS voltage

$$\begin{aligned} V_{rms} &= \left[\frac{q}{2\pi} \int_{\frac{1}{2}\pi - \frac{\pi}{q}}^{\frac{1}{2}\pi + \frac{\pi}{q}} (\sqrt{2} V \sin \omega t)^2 \, d\omega t \right]^{1/2} \\ &= \sqrt{2} V \left[\frac{1}{2} + \frac{q}{4\pi} \sin \frac{2\pi}{q} \right]^{1/2} \end{aligned}$$

Normalised peak to peak ripple voltage

$$\begin{aligned} v_{p-p} &= \sqrt{2} V - \sqrt{2} V \cos \frac{\pi}{q} \\ V_{n_{p-p}} &= \frac{v_{p-p}}{V_o} = \frac{\sqrt{2} V - \sqrt{2} V \cos \frac{\pi}{q}}{\frac{q}{\pi} \sqrt{2} V \sin \frac{\pi}{q}} = \frac{\pi}{q} \frac{1 - \cos \frac{\pi}{q}}{\sin \frac{\pi}{q}} \end{aligned}$$

Voltage form factor

$$FF_v = \frac{V_{rms}}{V_o} = \frac{\left[\frac{1}{2} + \frac{q}{4\pi} \sin \frac{2\pi}{q} \right]^{1/2}}{\frac{q}{\pi} \sin \frac{\pi}{q}}$$

whence the voltage ripple factor is

$$RF_v = \frac{1}{V_o} \left[V_{rms}^2 - V_o^2 \right]^{1/2} = \left[FF_v^2 - 1 \right]^{1/2}$$

As $q \rightarrow \infty$, $FF \rightarrow 1$, $RF \rightarrow 0$.

Diode reverse voltage

$$\hat{V}_{DR} = 2\sqrt{2}V \quad \text{if } q \text{ is even}$$

$$\hat{V}_{DR} = 2\sqrt{2}V \cos \frac{\pi}{2q} \quad \text{if } q \text{ is odd}$$

For a constant load current I_o , diode currents are

$$\hat{I}_D = I_o \quad \bar{I}_D = \frac{I_o}{q} \quad I_{D,rms} = \frac{I_o}{\sqrt{q}}$$

For a constant load current I_o the output power is

$$P_d = V_o I_o$$

The apparent power is

$$S = qVI_{rms}$$

The power factor on the secondary side of any transformer is

$$pf = \frac{P_d}{S} = \frac{V_o I_o}{qVI_{rms}} = \frac{1}{\sqrt{RF_v^2 + 1}}$$

$$= \frac{\frac{q}{\pi} \sqrt{2}V \sin \frac{\pi}{q} \times I_o}{qV \times I_o \sqrt{\frac{1}{q}}} = \frac{\sqrt{2q}}{\pi} \sin \frac{\pi}{q}$$

The primary side power factor is supply connection and transformer construction dependant.

For two-phase half-wave $p=q=2$

$$pf_{1\phi, 1/2} = \frac{V_o I_o}{V I_o} = \frac{2\sqrt{2}}{\pi} = 0.90$$

For three-phase half wave $p=q=3$

$$pf_{3\phi, 1/2} = \frac{V_o I_o}{3V I_o} = \frac{3\sqrt{3}}{2\pi} = 0.827$$

For six-phase half-wave $p=q=6$

$$pf_{6\phi, 1/2} = \frac{V_o I_o}{3V I_o} = \frac{3}{\pi} = 0.995 \quad (\text{Y conection})$$

The short circuit ratio (ratio actual s/c current to theoretical s/c current) is

$$K_{s/c} = \frac{q\sqrt{2}V / \omega L_c}{2\sqrt{2}V / \omega L_c \sin \frac{\pi}{q}} = \frac{q}{2 \sin \frac{\pi}{q}}$$

Commutation overlap angle

$$1 - \cos \mu = \frac{\omega L_c I_o}{\sqrt{2}V \sin \frac{\pi}{q}}$$

The commutation voltage drop

$$V_{com} = \frac{q}{2\pi} \omega L_c I_o \quad \text{where } 2L_c = L_{s/c}$$

$p=q=$	$I_{sec\ rms}$	RF_V	\bar{V}_o	\hat{V}_D	$\%V_{p-p}$	$K_{s/c}$	pf_{sec}	pf_{prim}
2	$I_o/\sqrt{2}$		0.90V	$2\sqrt{2}V$	0.157	1	0.636	0.90
3	$I_o/\sqrt{3}$	0.68	1.17V	$\sqrt{6}V$	0.604	1.73	0.675	0.827
6	$I_o/\sqrt{6}$	0.31	1.35V	$2\sqrt{2}V$	0.140	6	0.55	0.995

For three-phase resistive load, with transformer turns ratio 1:N

$$I_o = \frac{\sqrt{2}V}{R} \frac{3\sqrt{3}}{2\pi} \quad I_{o\ rms} = \frac{V}{R} \left[\frac{1}{3} + \frac{\sqrt{3}}{4\pi} \right]^{1/2}$$

$$FF_{i\ output} = \left[\frac{2\pi^2}{27} + \frac{\pi}{6\sqrt{3}} \right]^{1/2}$$

$$I_{p\Delta} = \frac{N}{1} \times \frac{V}{R} \left[\frac{1}{3} + \frac{\sqrt{3}}{4\pi} - \frac{3}{2\pi^2} \right]^{1/2} \quad I_{L\Delta} = \frac{N}{1} \times \frac{V}{R} \left[\frac{2}{3} + \frac{\sqrt{3}}{2\pi} \right]^{1/2}$$

$$I_{LY} = \frac{N}{1} \times \frac{V}{R} \left[\frac{2}{9} + \frac{\sqrt{3}}{6\pi} \right]^{1/2}$$

Time domain half-wave single phase R-L-E load

$$i_o(\omega t) = -\frac{E}{R} + \frac{\sqrt{2}V}{Z} \left(\sin(\omega t - \phi) + \left[\frac{E}{R} \frac{Z}{\sqrt{2}V} - \sin(\omega t - \phi) \right] e^{-\frac{\omega t - \alpha}{\tan \phi}} \right)$$

$$v_o(\omega t) = V_o \left[1 + \sum_{k=1}^{\infty} \frac{-2(-1)^k}{k^2 q^2 - 1} \cos(kq\omega t) \right]$$

Full-wave diode bridge rectifiers - star [see figures 13.9, 13.14]

q phases and $2q$ diodes

Mean voltage

$$V_o = \frac{q}{\pi} \int_{\frac{1}{2}\pi - \frac{\pi}{q}}^{\frac{1}{2}\pi + \frac{\pi}{q}} \sqrt{2}V \sin \omega t \, d\omega t$$

$$= \frac{2q}{\pi} \sqrt{2}V \sin \frac{\pi}{q}$$

Pulse number

$$p=q \quad \text{if } q \text{ is even}$$

$$p=2q \quad \text{if } q \text{ is odd}$$

Diode reverse voltage

$$\hat{V}_{D_R} = 2\sqrt{2}V \quad \text{if } q \text{ is even}$$

$$\hat{V}_{D_R} = 2\sqrt{2}V \cos \frac{\pi}{2q} \quad \text{if } q \text{ is odd}$$

For a constant load current I_o , diode currents are

$$\hat{I}_D = I_o \quad \bar{I}_D = \frac{I_o}{q} \quad I_{D\ rms} = \frac{I_o}{\sqrt{q}}$$

The current and power factor are

$$I_{rms} = I_o \sqrt{\frac{2}{q}}$$

$$pf = \frac{P_d}{S} = \frac{V_o I_o}{qVI_{rms}} = \frac{\frac{2q}{\pi} \sqrt{2}V \sin \frac{\pi}{q} \times I_o}{qV \times I_o \sqrt{\frac{2}{q}}} = \frac{2\sqrt{q}}{\pi} \sin \frac{\pi}{q}$$

which is $\sqrt{2}$ larger than the half-wave case.

For single-phase, full-wave $p=q=2$

$$pf_{1\phi} = \frac{V_o I_o}{VI_o} = \frac{2\sqrt{2}}{\pi} = 0.90$$

For three-phase full-wave $p=2$ $q=6$

$$pf_{3\phi} = \frac{V_o I_o}{3VI_o} = \frac{\frac{6}{\pi} \sqrt{2}V \times \frac{1}{2}I_o}{3V \times \frac{\sqrt{2}}{3}I_o} = \frac{3}{\pi} = 0.955$$

p, q	I_{sec}	RF_v	\bar{V}_o	\hat{V}_D	$\% V_{p-p}$	$K_{s/c}$	$pf_{Y prim}$	pf_{sec}
$p=q=2$	I_o	0.483	1.80V	$2\sqrt{2} V$	0.157	$2/\pi$	0.90	0.90
$p=2, q=6$	$\sqrt{3/2} I_o$	0.31	2.34V	$\sqrt{6} V$	0.140	$6/\pi$	0.995	0.995

The short circuit ratio (ratio actual s/c current to theoretical s/c current) is

$$K_{s/c} = \frac{q}{2\pi \sin \frac{\pi}{q}}$$

which is smaller by a factor π than the half-wave case.

$$K_{s/c} = \frac{q}{\pi} \text{ for } q = 2$$

Relationship between current ripple factor and supply side power factor on the primary

$$RF_i = \frac{1}{I_1} \sqrt{\sum_{h=3}^{\infty} I_h^2} = \frac{1}{I_1} \sqrt{I_{rms}^2 - I_1^2}$$

$$pf = \frac{I_1}{I_{rms}} = \frac{1}{\sqrt{1 + RF_i^2}}$$

For single phase $p=2$

$$RF_i = \frac{1}{I_1} \sqrt{I_{rms}^2 - I_1^2}$$

$$= \frac{\sqrt{I_o^2 - \left(\frac{1}{\sqrt{2}} \frac{4}{\pi} I_o\right)^2}}{\frac{1}{\sqrt{2}} \frac{4}{\pi} I_o} = \sqrt{\frac{\pi^2 - 8}{8}} = 0.483$$

$$pf = \frac{1}{\sqrt{1 + RF_i^2}} = \frac{1}{\sqrt{1 + \frac{\pi^2 - 8}{8}}} = \frac{2\sqrt{2}}{\pi} = 0.90$$

The rms of the fundamental component is

$$I_1 = \frac{1}{\sqrt{2}} \frac{4}{\pi} I_o$$

The rms of the harmonic components are

$$I_h = \frac{I_1}{h} = \frac{I_1}{kp \pm 1} \text{ for } k \geq 1, 2, 3, \dots$$

For p-pulse

$$RF_v = \sqrt{\frac{\frac{\pi^2}{p^2}}{\sin^2 \frac{\pi}{p}} - 1}$$

$$pf = \frac{1}{\sqrt{1 + RF_v^2}} = \frac{p}{\pi} \sin \frac{\pi}{p}$$

Commutation overlap angle

$$1 - \cos \mu = \frac{\omega L_c I_o}{\sqrt{2} V \sin \frac{\pi}{q}}$$

The commutation voltage drop

$$v_{com} = \frac{q}{\pi} \omega L_c I_o \text{ where } 2L_c = L_{s/c}$$

For $p=q=2$, only

$$1 - \cos \mu = \frac{2\omega L_c I_o}{\sqrt{2} V}$$

$$v_{com} = \frac{4}{\pi} \omega L_c I_o$$

Load characteristics

$$\text{Current Form Factor} = FF_I = \frac{I_{o,rms}}{I_o} = \frac{I_o \sqrt{\frac{2}{q}}}{I_o} = \sqrt{\frac{2}{q}}$$

Full-wave diode bridge rectifiers – delta

Same expression as for delta connected secondary, except supply voltages V are replaced by

$$\frac{V}{2 \sin \frac{\pi}{q}}$$

For example in three-phase, V is replaced by $V/\sqrt{3}$, that is, $V_{L-L} = \sqrt{3}V_{L-N} = \sqrt{3}V_{phase}$

The mean output voltage is

$$V_o = \frac{2q}{\pi} \sqrt{2}V_{\Delta} \sin \frac{\pi}{q} = \frac{2q}{\pi} \sqrt{2} \frac{V}{2 \sin \frac{\pi}{q}} \sin \frac{\pi}{q} = \frac{q}{\pi} \sqrt{2} V$$

Pulse number

$$\begin{aligned} p &= q & \text{if } q \text{ is even} \\ p &= 2q & \text{if } q \text{ is odd} \end{aligned}$$

diode reverse voltage and currents

$$\hat{V}_{D_R} = \frac{\sqrt{2}V}{\sin \frac{\pi}{q}} \quad \text{if } q \text{ is even}$$

$$\hat{V}_{D_R} = \frac{\sqrt{2}V}{2 \sin \frac{\pi}{2q}} \quad \text{if } q \text{ is odd}$$

$$\hat{I}_D = I_o \quad \bar{I}_D = I_o / q \quad I_{D,rms} = I_o / \sqrt{q}$$

rms current and power factor

$$\begin{aligned} I_{rms\ even} &= \frac{I_o}{2} & pf_{q\ even} &= \frac{V_o I_o}{q V I_{rms}} = \frac{\frac{q}{\pi} \sqrt{2} V I_o}{q V \frac{1}{2} I_o} = \frac{2\sqrt{2}}{\pi} \\ I_{rms\ odd} &= \frac{I_o}{2} \frac{[q^2 - 1]^{1/2}}{q} & pf_{q\ odd} &= \frac{V_o I_o}{q V I_{rms}} = \frac{2\sqrt{2}}{\pi} \frac{q}{[q^2 - 1]^{1/2}} \end{aligned}$$

Commutation angle and voltage

$$\begin{aligned} 1 - \cos \mu &= \frac{\omega L I_o}{\sqrt{2} V} & v_{com} &= \frac{q}{2\pi} \omega L_c I_o & q \text{ even} \\ 1 - \cos \mu &= \frac{\omega L I_o}{\sqrt{2} V} \left(1 - \frac{1}{q}\right) & v_{com} &= \frac{q}{2\pi} \omega L_c I_o \left(1 - \frac{1}{q}\right) & q \text{ odd} \end{aligned}$$

The short circuit ratio (ratio actual s/c current to theoretical s/c current) is

$$K_{s/c\ even} = \frac{q}{\pi} \sin \frac{\pi}{q} \quad K_{s/c\ odd} = \frac{q-1}{\pi} \sin \frac{\pi}{q}$$

For single-phase resistive load, with transformer turns ratio 1:N

$$\begin{aligned} I_o &= \frac{\sqrt{2}V}{R} \frac{4}{\pi} & I_{o,rms} &= \frac{2V}{R} \\ FF_{i\ output} &= \frac{\pi}{2\sqrt{2}} & RF_v &= \sqrt{FF^2 - 1} = \sqrt{\frac{\pi^2}{8} - 1} \\ I_p &= \frac{N}{1} I_{sec} = \frac{N}{1} \times \frac{2V}{R} & pf &= \frac{1}{\sqrt{RF^2 + 1}} = \frac{2\sqrt{2}}{\pi} \end{aligned}$$

Reading list

Dewan, S. B. and Straughen, A., *Power Semiconductor Circuits*, John Wiley and Sons, New York, 1975.

Sen, P.C., *Power Electronics*, McGraw-Hill, 5th reprint, 1992.

Shepherd, W *et al.* *Power Electronics and motor control*, Cambridge University Press, 2nd Edition 1995.

<http://www.ipes.ethz.ch/>

<http://www.celnav.de/hv/hv9.htm>

http://www.physiqueindustrie.com/custom_converter.php

<http://www.voltagemultipliers.com/html/multdesign.html>

Problems

- 13.1. Derive equations (13.35) and (13.36) for the circuit in figure 13.7.
- 13.2. Assuming a constant load current, derive an expression for the mean and rms device current and the device form factor, for the circuits in figure 13.9.
- 13.3. The single-phase full-wave uncontrolled rectifier is operated from the 415 V line-to-line voltage, 50 Hz supply, with a series load of $10\Omega + 5\text{mH} + 40\text{ V battery}$. Derive the load voltage expression in terms of a Fourier series. Determine the rms value of the fundamental of the load current.
- 13.4. A single-phase uncontrolled rectifier has a 24Ω resistive load a 240V ac 50Hz supply. Determine the average, peak and rms current and peak reverse voltage across each rectifier diode for
- an isolating transformer with a 1:1 turns ratio
 - centre-tapped transformer with turns ratio 1:1:1.
- 13.5. A single-phase bridge rectifier has an R - L of $R = 20\Omega$ and $L = 50\text{mH}$ and a 240V ac 50Hz source voltage. Determine:
- the average and rms currents of the diodes and load
 - rms and average 50Hz source currents
 - the power absorbed by the load
 - the supply power factor
- 13.6. A single-phase, full-wave uncontrolled rectifier has a back emf E_b in its load. If the supply is 240Vac 50Hz and the series load is $R = 20\Omega$, $L = 50\text{mH}$, and $E_b = 120\text{V dc}$, determine:
- the power absorbed by the dc source in the load
 - the power absorbed by the load resistor
 - the power delivered from the ac source
 - the ac source power factor
 - the peak-to-peak load current variation if only the first ac term of the Fourier series for the load current is considered.
- 13.7. A three-phase uncontrolled rectifier is supplied from a 50Hz 415V ac line-to-line voltage source. If the rectifier load is a 75Ω resistor, determine
- the average load current
 - the rms load current
 - the rms source current
 - the supply power factor.
- 13.8. A three-phase uncontrolled rectifier is supplied from a 50Hz 415V ac line-to-line voltage source. If the rectifier load is a series R - L circuit where $R = 10\Omega$ and $L = 100\text{mH}$, determine:
- the average and rms load currents
 - the average and rms diode currents
 - the rms source and power current
 - the supply power factor.

Table 13.7. Characteristics of single-phase rectifier circuits with a resistive load





$P = I_o^2 R$ $V_o = I_o R$ $\eta = \frac{I_o^2}{I_o^2{}_{rms}}$			
			
Load Voltage and Current Waveshape Characteristic			
Diode Average Current $I_{F(AV)}/I_{L(DC)}$	1.00	0.50	0.50
Diode Peak Current $I_{FM}/I_{F(AV)}$	3.14	3.14	3.14
Form Factor of Diode $I_{F(RMS)}/I_{L(DC)}$	1.57	1.57	1.57
Diode RMS Current $I_{F(RMS)}/I_{L(DC)}$	1.57	0.785	0.785
RMS Input Voltage Per Transformer Leg $V_i/V_{L(DC)}$	2.22	1.11	1.11
Peak Inverse Voltage $V_{RRM}/V_{L(DC)}$	3.14	3.14	1.57
Transformer Primary Rating VA/P _{DC}	3.49	1.23	1.23
Transformer Secondary Rating VA/P _{DC}	3.49	1.75	1.23
Total RMS Ripple, %	121	48.2	48.2
Lowest Ripple Frequency, f_r/f_i	1	2	2
Rectification Ratio (Conversion Efficiency), %	40.6	81.2	81.2

Table 13.8. Characteristics of three-phase rectifier circuits with a resistive load

	Half-wave Star	Bridge	Double Wye with Interphase Transformer	Full-wave Star	Wye-Delta Connections	
					Parallel	Series
Average Current through Diode $I_{F(AV)}/I_{L(DC)}$	0.333	0.333	0.167	0.167	0.167	0.333
Peak Current through Diode $I_{FM}/I_{F(AV)}$	3.63	3.14	3.15	6.30	6.30	6.30
Form Factor of Current through Diode $I_{F(RMS)}/I_{L(DC)}$	1.76	1.74	1.76	2.46	2.46	2.46
RMS Current through Diode $I_{F(RMS)}/I_{L(DC)}$	0.587	0.579	0.293	0.409	0.409	0.818
RMS Input Voltage Per Transformer Leg $V_i/V_{L(DC)}$	0.855	0.428	0.855	0.741	0.715	0.37
Diode Peak Inverse Voltage $V_{RRM}/V_{L(DC)}$	2.09	1.05	2.42	2.09	1.05	1.05
Transformer Primary Rating VA/P _{DC}	1.23	1.05	1.06	1.28	1.01	1.01
Transformer Secondary Rating VA/P _{DC}	1.50	1.05	1.49	1.81	1.05	1.05
Total RMS Ripple, %	18.2	4.2	4.2	4.2	1.0	1.0
Lowest Ripple Frequency, f_r/f_i	3	6	6	6	12	12
Rectification Ratio (Conversion Efficiency), %	96.8	99.8	99.8	99.8	100	100

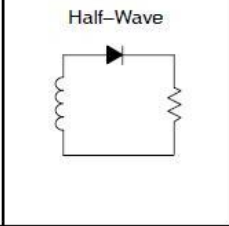
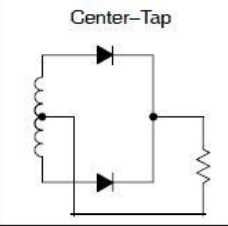
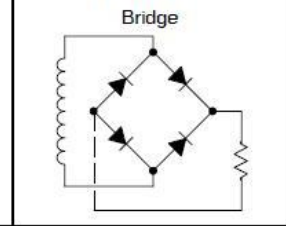
Table 13.9. Characteristics of rectifiers with an L - C output filter

Rectifier Circuit Connection	Single-Phase Full-Wave Center-Tap	Single-Phase Full-Wave Bridge	Three Phase Half-Wave Star	Three-Phase Full-Wave Bridge	Three-Phase Double Wye With Interphase Transformer
Characteristic					
‡Average Current Through Diode $I_{F(AV)}/I_{L(DC)}$	0.500	0.500	0.333	0.333	0.167
‡Peak Current Through Diode $I_{FM}/I_{F(AV)}$	2.00	2.00	3.00	3.00	3.00
Form Factor of Current Through Diode $I_{F(RMS)}/I_{F(AV)}$	1.41	1.41	1.73	1.73	1.76
RMS Input Voltage Per Transformer Leg $V_I/V_{L(DC)}$	1.11*	1.11	0.855	0.428	0.885
Diode Peak Inverse Voltage (PIV) $V_{RRM}/V_{L(DC)}$	3.14	1.57	2.09	1.05	2.42
Transformer Primary Rating V_A/P_{DC}	1.11	1.11	1.21	1.05	1.05
Transformer Secondary Rating V_A/P_{DC}	1.57	1.11	1.48	1.05	1.48
Ripple ($V_F/V_{L(DC)}$) Lowest frequency in rectifier output (f_r/f_1) Peak Value of Ripple	2	2	3	6	6
Components:					
Ripple frequency (fundamental)	0.667	0.667	0.250	0.057	0.057†
Second harmonic	0.133	0.133	0.057	0.014	0.014
Third harmonic	0.057	0.057	0.025	0.006	0.006
Ripple peaks with reference to dc axis:					
Positive peak	0.363	0.363	0.209	0.0472	0.0472
Negative peak	0.837	0.637	0.395	0.0930	0.0930

Table 13.10. Characteristics of multi-phase topologies

	3-ph star (single-way)	6-ph star (single-way)	6-pulse bridge	12-pulse series br.	12-pulse parallel br.
Peak reverse voltage V_{RRM}	$2.092 V_{DC}$	$2.092 V_{DC}$	$1.05 V_{DC}$	$0.524 V_{DC}$	$1.05 V_{DC}$
r.m.s. input voltage V_{Srms}	$0.855 V_{DC}$	$0.74 V_{DC}$	$0.428 V_{DC}$	$0.37 V_{DC}$	$0.715 V_{DC}$
Diode average current $I_{F(AV)}$	$0.333 I_{DC}$	$0.167 I_{DC}$	$0.333 I_{DC}$	$0.333 I_{DC}$	$0.167 I_{DC}$
Diode forward current I_{FRM}	$3.63 I_{F(AV)}$	$6.28 I_{F(AV)}$	$3.14 I_{F(AV)}$	$3.033 I_{F(AV)}$	$3.14 I_{F(AV)}$
Diode r.m.s. current $I_{F(rms)}$	$0.587 I_{DC}$	$0.409 I_{DC}$	$0.579 I_{DC}$	$0.576 I_{DC}$	$0.409 I_{DC}$
Curr. form factor – $I_{F(rms)}/I_{F(AV)}$	1.76	2.45	1.74	1.73	2.45
Form factor – FF	1.0165	1.0009	1.0009	1.00005	1.00005
Rectification ratio – η	0.968	0.998	0.998	1.00	1.00
Ripple factor – RF	0.182	0.042	0.042	0.01	0.01
Transf. rating primary V_A	$1.23 P_{DC}$	$1.28 P_{DC}$	$1.05 P_{DC}$	$1.01 P_{DC}$	$1.01 P_{DC}$
Transf. rating secondary V_A	$1.51 P_{DC}$	$1.81 P_{DC}$	$1.05 P_{DC}$	$1.05 P_{DC}$	$1.05 P_{DC}$
Transf. Utilization Factor – TUF	0.73	0.647	0.952	0.971	0.971
Output ripple freq. f_r	$3 f_{mains}$	$6 f_{mains}$	$6 f_{mains}$	$12 f_{mains}$	$12 f_{mains}$

Symmetry	Condition Required	Fourier Coefficients
Even	$f(-t) = f(t)$	$a_n = \frac{2}{\pi} \int_0^{\pi} f(t) \cos(n\omega t) d(\omega t) \quad b_n = 0$
Odd	$f(-t) = -f(t)$	$a_n = 0 \quad b_n = \frac{2}{\pi} \int_0^{\pi} f(t) \sin(n\omega t) d(\omega t)$
Half-wave	$f(t) = -f(t + \frac{1}{2}T)$	$a_n = b_n = 0$ for even n $a_n = \frac{2}{\pi} \int_0^{\pi} f(t) \cos(n\omega t) d(\omega t)$ for odd n $b_n = \frac{2}{\pi} \int_0^{\pi} f(t) \sin(n\omega t) d(\omega t)$ for odd n
Even quarter-wave	Even and half-wave	$a_n = \begin{cases} \frac{4}{\pi} \int_0^{\pi/2} f(t) \cos(n\omega t) d(\omega t) & \text{for odd } n \\ 0 & \text{for even } n \end{cases}$ $b_n = 0$ for all n
Odd quarter-wave	Odd and half-wave	$a_n = 0$ for all n $b_n = \begin{cases} \frac{4}{\pi} \int_0^{\pi/2} f(t) \sin(n\omega t) d(\omega t) & \text{for odd } n \\ 0 & \text{for even } n \end{cases}$