

# CHAPTER 10

## Switching-aid Circuits with Energy Recovery

Passive turn-on and turn-off snubber circuits for the IGBT transistor, the GCT and the GTO thyristor have been considered in chapter 9. These snubber circuits modify the device  $I$ - $V$  switching trajectory and in so doing reduce the device transient losses. Snubber circuit action involves temporary energy stored in either an inductor or capacitor. In resetting these passive components it is usual to dissipate the stored energy in a resistor as heat. At high frequencies these losses (being proportional to frequency) may become a limiting factor because of the difficulties associated with equipment cooling. Instead of dissipating the switching-aid circuit stored energy, it may be viable to recover the energy back into the dc supply or into the load, or both. Two classifications of energy recovery circuits exist, either passive or active. A *passive recovery* circuit involves only passive components such as  $L$  and  $C$  while *active recovery* techniques involve extra switching devices, as in a switched-mode power supply, smps.

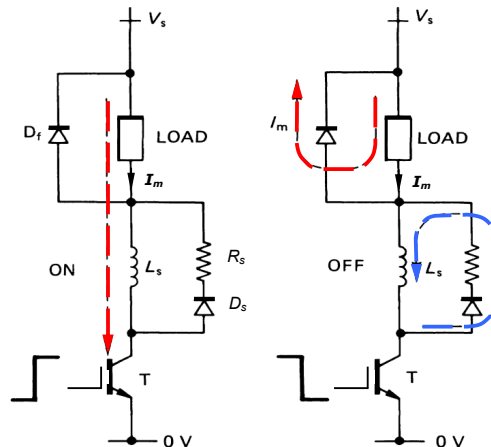

Figure 10.1. Conventional inductive turn-on snubber principal currents at: (a) turn-on and (b) turn-off.

### 10.1 Energy recovery for inductive turn-on snubber circuits – single ended

Figure 10.1 shows the conventional inductive turn-on snubber circuit for a single-ended IGBT transistor switching circuit. Equally the switch may be a GCT or a GTO thyristor, for which an inductive turn-on snubber is mandatory, if switch derating is to be avoided.

At switch turn-on the snubber inductance controls the rate of rise of current as the collector voltage falls to zero. The switch turns on without the stressful condition of simultaneous maximum voltage and current ( $V_s, I_m$ ) being experienced. At turn-off the inductor current is diverted through the diode  $D_s$  and

resistor  $R_s$  network and the stored inductor energy  $\frac{1}{2}LI_m^2$  is dissipated as heat in the resistance of the  $L_s$ - $R_s$ - $D_s$  circuit. The power loss is determined by the switching frequency and is given by  $\frac{1}{2}LI_m^2f_s$ . Full design and operational aspects of this turn-on snubber have been considered in chapter 9.3.3.

#### 10.1.1 Passive recovery

##### i. Recovery into the dc supply

Figure 10.2 shows a magnetic coupled circuit technique for passively recovering the inductive turn-on snubber stored energy back into the dc supply  $V_s$ . The inductor is bifilar-wound with a catch winding. The primary winding is designed to give the required (magnetising) inductance based on core dimensions, properties, and number of turns,  $L = N^2/R$ . At switch turn-off the current in the coupled inductor primary is diverted to the secondary so as to maintain continuous core flux. The windings are arranged to transfer current back into the supply via a diode  $D_R$  which prevents reverse current flow.

The operating principles of this turn-on snubber recovery scheme are simple but a number of important circuit characteristics are exhibited. Let the coupled inductor have a primary-to-secondary turns ratio of  $1:N$ . At turn-off the catch (secondary) winding conducts and its voltage is thereby clamped to the supply rail  $V_s$ . The primary winding therefore has an induced voltage specified by the turns ratio. That is

$$V_{ip} = \frac{1}{N}V_s \quad (V) \quad (10.1)$$

The switch collector voltage at turn-off is increased, above the supply voltage, by this component, to

$$V_c = \left(1 + \frac{1}{N}\right)V_s \quad (V) \quad (10.2)$$

The turns ratio  $N$  should be large so as to minimise the switch voltage rating in excess of  $V_s$ .

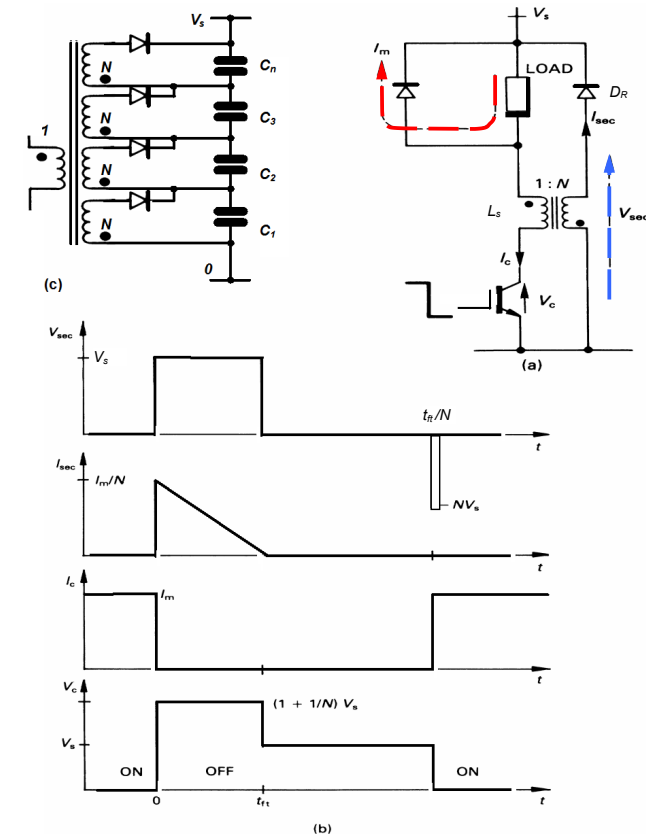

Figure 10.2. Turn-on snubber with snubber energy recovery via a secondary catch winding: (a) circuit diagram; (b) circuit waveforms; and (c) multilevel recovery.



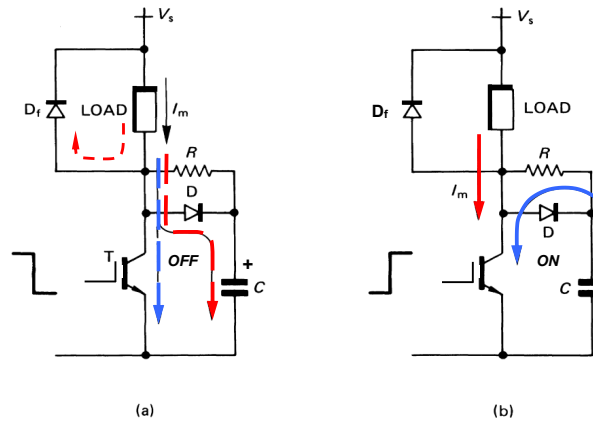

Figure 10.5. Conventional capacitive turn-off snubber showing currents at IGBT transistor: (a) turn-off and (b) turn-on.

**10.2 Energy recovery for capacitive turn-off snubber circuits – single ended**

Figure 10.5 shows the conventional capacitive turn-off snubber circuit used with both the GTO thyristor and the IGBT transistor. At turn-off, collector current is diverted into the snubber capacitor C via D. The switch turns off clamped to the capacitor voltage which increases quadratically from zero. At the subsequent switch turn-on the energy stored in C,  $\frac{1}{2}CV_s^2$  is dissipated as heat, mainly in the resistor R. A full functional description and design procedure for the capacitive turn-off snubber circuit is to be found in chapter 9.3.1.

At high voltages and switching frequencies, with slow switching devices, snubber losses ( $\frac{1}{2}CV_s^2f_s$ ) may be too high to be readily dissipated. An alternative is to recover this energy (either into the load or back into the dc supply), using either passive or active recovery techniques.

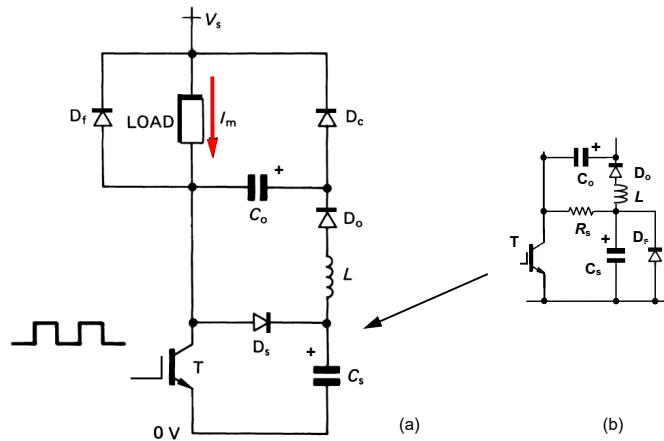

Figure 10.6. A capacitive turn-off snubber with passive capacitor energy recovery into the load: (a) with a capacitive turn-off snubber and (b) with an RC turn-off snubber.

**10.2.1 Passive recovery**

**i. Recovery into the load**

Figure 10.6 illustrates a passive, lossless, capacitive turn-off snubber energy recovery scheme which dumps the snubber energy,  $\frac{1}{2}CV_s^2f_s$ , into the load. The switch turn-off protection is that with a conventional capacitive snubber circuit.

At turn-off the snubber capacitor  $C_s$  charges to the voltage rail  $V_s$  as shown in figure 10.7a.

At subsequent switch turn-on, the load current diverts from the freewheeling diode  $D_f$  to the switch T. Simultaneously the snubber capacitor  $C_s$  resonates its charge to capacitor  $C_o$  through the path shown in figure 10.7b, T -  $C_s$  - L -  $D_o$  -  $C_o$ .

When the switch next turns off, the snubber capacitor  $C_s$  charges and the capacitor  $C_o$  discharges into the load. When  $C_o$  is discharged, the freewheeling diode conducts. During turn-off  $C_o$  and  $C_s$  act effectively in parallel across the switching device.

A convenient starting point for the analysis of the recovery scheme is at switch turn-on when snubber energy is transferred from  $C_s$  to  $C_o$ .

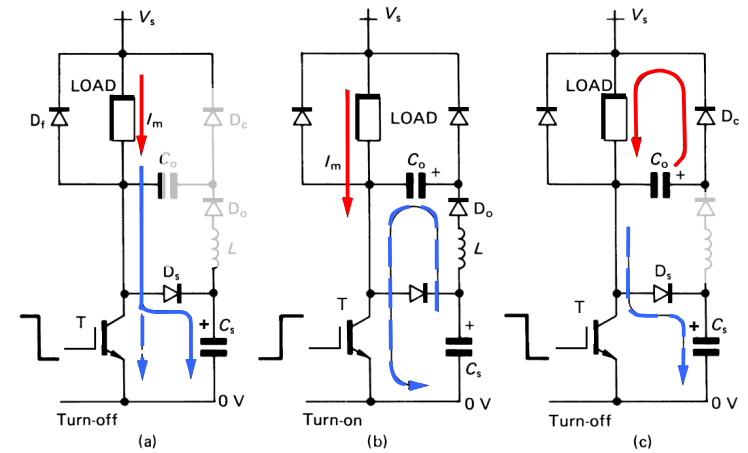

Figure 10.7. Energy recovery turn-off snubber showing the energy recovery stages: (a) conventional snubber action at turn-off; (b) intermediate energy transfer at subsequent switch turn-on; and (c) transferred energy dumped into the load at subsequent switch turn-off.

**At switch turn-on**

The active equivalent circuit portions of figure 10.7b are shown in figure 10.8a. Analysis of the L-C resonant circuit with the initial conditions shown yields the following capacitor voltage and current equations. The resonant current is given by

$$i(\omega t) = \frac{V_s}{Z} \sin \omega t \tag{10.11}$$

where  $Z = \omega L = \frac{1}{\omega C_o} = Z_o \sqrt{\frac{n+1}{n}}$  (ohms)  $Z_o = \sqrt{\frac{L}{C_o}}$  (ohms)

$\omega = \omega_o \sqrt{\frac{n+1}{n}}$  (rad/s)  $\omega_o = \frac{1}{\sqrt{LC_o}}$  (rad/s)

$n = \frac{C_s}{C_o}$

The snubber capacitor voltage decreases from  $V_s$  according to

$$V_{Cs} = V_s \left\{ 1 - \frac{1}{1+n} (1 - \cos \omega t) \right\} \tag{10.12}$$

while the transfer capacitor voltage charges from zero according to

$$V_{Co} = V_s \frac{n}{1+n} (1 - \cos \omega t) \tag{10.13}$$

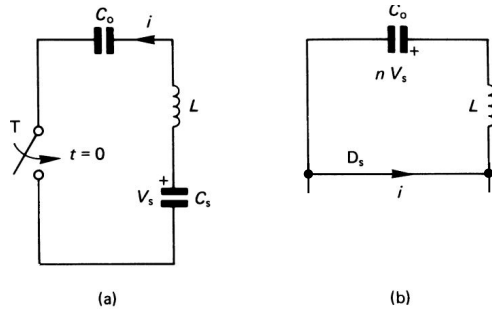

Figure 10.8. Equivalent circuit for the intermediate energy transfer phase of snubber energy recovery, occurring via: (a) the main switch T and (b) then via the snubber diode  $D_s$ .

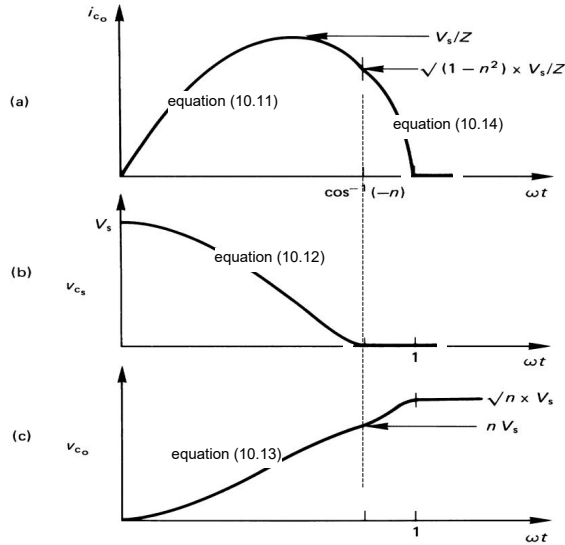

Figure 10.9. Circuit waveforms during intermediate energy transfer phase of snubber energy recovery: (a) transfer capacitor  $C_o$  current; (b) snubber capacitor voltage; and (c) transfer capacitor voltage.

Examination of equation (10.12) shows that if  $n > 1$ , the final snubber capacitor  $C_s$  voltage at  $\omega t = \pi$  will be positive. It is required that  $C_s$  retains no charge, ready for subsequent switch turn-off; thus  $n \leq 1$ , that is  $C_o \geq C_s$ . If  $C_o$  is greater than  $C_s$  equation (10.12) predicts  $C_s$  will retain a negative voltage. Within the practical circuit of figure 10.6,  $C_s$  will be clamped to zero volts by diode  $D_s$  conducting and allowing the remaining stored energy in  $L$  to be transferred to  $C_o$ . The new equivalent circuit for  $\omega t = \cos^{-1}(-n)$  is shown in figure 10.8b. The resonant current, hence transfer capacitor voltage are given by

$$i(\omega_o t) = \frac{V_s}{Z} \sin(\omega_o t + \phi) \quad (A) \quad (10.14)$$

$$V_{C_o} = \sqrt{n} V_s \cos(\omega_o t + \phi) \quad (V)$$

where  $t \geq 0$  and  $\phi = -\tan^{-1} \sqrt{\frac{1-n^2}{n}}$ .

In maintaining energy balance, from equation (10.14) when the inductor  $L$  current  $i(\omega t) = 0$ , the final voltage on  $C_o$  is  $\sqrt{n} V_s$  and  $C_s$  retains no charge,  $V_{C_s} = 0$ .

The voltage and current waveforms for the resonant energy transfer stage are shown in figure 10.9.

**At switch turn-off**

Energy dumping from  $C_o$  into the load and snubber action occur in parallel and commence when the switch is turned off. As the collector current falls to zero in time  $t_{ff}$  a number of serial phases occur. These phases, depicted by capacitor voltage and current waveforms, are shown in figure 10.10.

**Phase one**

Capacitor  $C_o$  is charged to  $\sqrt{n} V_s$ , so until the snubber capacitor  $C_s$  charges to  $(1 - \sqrt{n}) V_s$ ,  $C_o$  is inactive. Conventional snubber turn-off action occurs as discussed in chapter 9.3.1. The snubber capacitor voltage increases according to

$$V_{C_s} = \frac{1}{2} \frac{I_m}{C_s t_{ff}} t^2 \quad (V) \quad (10.15)$$

while  $C_o$  remains charged with a constant voltage of  $\sqrt{n} V_s$ . This first phase is complete at  $t_o$  when

$$V_{C_s} = V_o = \frac{1}{2} \frac{I_m t_o^2}{C_s t_{ff}} = (1 - \sqrt{n}) V_s \quad (V) \quad (10.16)$$

whence

$$t_o = \sqrt{\frac{2(1 - \sqrt{n}) V_s C_s t_{ff}}{I_m}} \quad (s) \quad (10.17)$$

and the collector current

$$I_o = I_m \left(1 - \frac{t_o}{t_{ff}}\right) \quad (A) \quad (10.18)$$

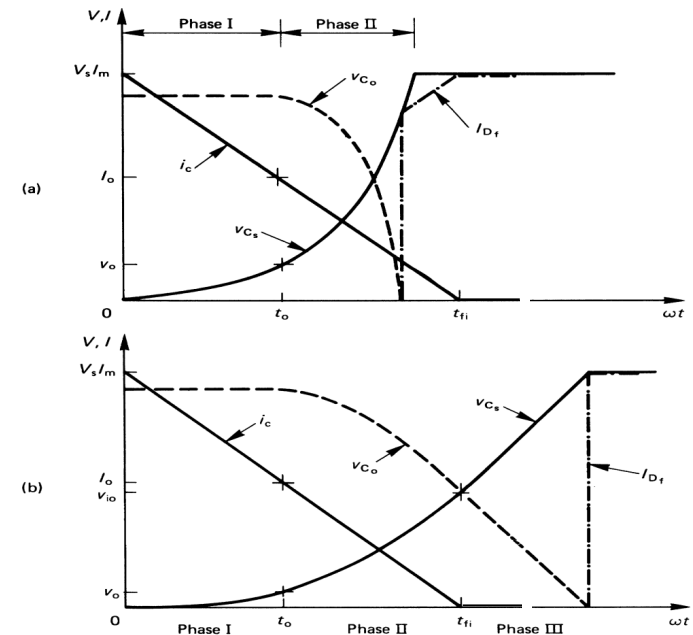

Figure 10.10. Circuit waveforms at switch turn-off with turn-off snubber energy recovery when: (a) the snubber  $C_s$  is fully charged before the switch current at turn-off reaches zero and (b) the switch collector current has fallen to zero before the snubber capacitor has charged to  $V_s$ .

**Phase two**

When  $C_s$  charges to  $(1 - \sqrt{n}) V_s$ , the capacitor  $C_o$  begins to discharge into the load. The equivalent circuit is shown in figure 10.11a, where the load current is assumed constant while the collector current fall is assumed linear. The following Kirchhoff conditions must be satisfied

$$V_s = V_{C_s} + V_{C_o} \quad (\text{V}) \quad (10.19)$$

$$I_m = i_{C_o} + i_{C_s} + I_o(1 - t/t_n) \quad (\text{A}) \quad (10.20)$$

for  $0 \leq t \leq t_n - t_o$

Under these conditions, the snubber capacitor voltage increases according to

$$V_{C_s} = \frac{n}{1+n} \frac{1}{C_s} [(I_m - I_o)t + \frac{1}{2} V_2 t^2 / t_o] + (1 - \sqrt{n}) V_s \quad (\text{V}) \quad (10.21)$$

with a current

$$i_{C_s} = \frac{1}{1+n} (I_m - I_o(1 - t/t_o)) \quad (\text{A}) \quad (10.22)$$

The transfer dump capacitor  $C_o$  discharges with a current given by

$$i_{C_o} = i_{C_s} / n \quad (10.23)$$

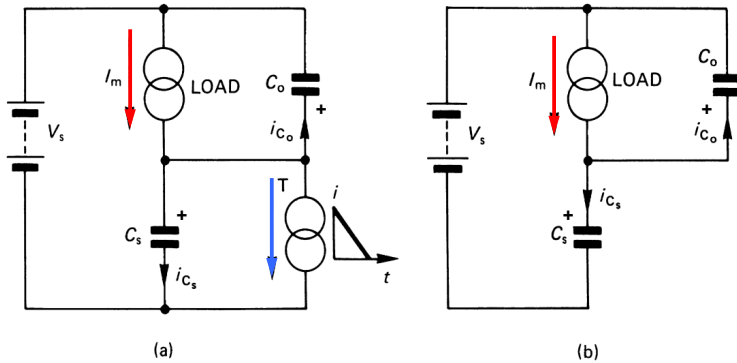

Figure 10.11. Turn-off snubber equivalent circuit during energy recovery into the load when: (a)  $C_o$  begins to conduct and (b) after the switch has turned off.

### Phase three

If the snubber capacitor has not charged to the supply rail voltage before the switch collector current has reached zero, phase three will occur as shown in figure 10.10b. The equivalent circuit to be analysed is shown in figure 10.11b. The Kirchhoff equations describing this phase are similar to equations (10.19) and (10.20) except that in equation (10.20) the component  $I_o(1 - t/t_o)$  is zero.

The capacitor  $C_s$ , charging current is given by

$$i_{C_s} = \frac{n}{1+n} I_m \quad (\text{A}) \quad (10.24)$$

while the dumping capacitor  $C_o$  current is

$$i_{C_o} = i_{C_s} / n \quad (\text{A}) \quad (10.25)$$

The snubber capacitor charges linearly, according to

$$V_{C_s} = V_o + \frac{n}{1+n} \frac{I_m}{C_s} t \quad (\text{V}) \quad (10.26)$$

When  $C_s$  is charged to the rail voltage  $V_s$ ,  $C_o$  is discharged and the load freewheeling diode conducts the full load current  $I_m$ .

Since the snubber capacitor energy is recovered there is no energy loss penalty for using a large snubber capacitance and the larger the capacitance, the lower the switch turn-off switching loss. The energy to be recovered into the load is fixed,  $\frac{1}{2} C_s V_s^2$  and at low load current levels the long discharge time of  $C_o$  may inhibit proper snubber circuit action. This is generally not critical since switching losses are small at low load current levels. Output voltage regulation is reduced, since the amount of energy recovered into the load is independent of the load current.

### ii. Recovery into the dc supply

Figure 10.12 show two turn-off snubber circuits where the energy is recovered back into the dc supply. The ac circuit operational mechanisms are the same for both circuits.

When the switch T is turned off the snubber capacitor  $C_s$  charges to the dc rail voltage  $V_s$ .

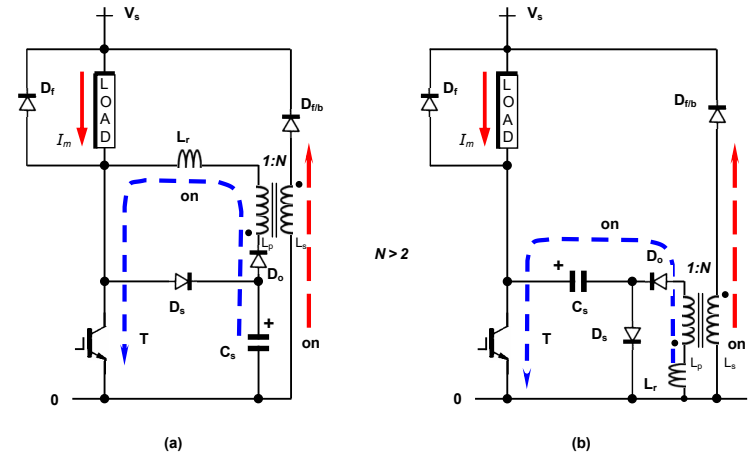

Figure 10.12. A capacitive turn-off snubber with passive energy recovery into the supply: (a) basic capacitive turn-off snubber and (b) an alternative dc configuration.

At switch T turn-on, the snubber capacitor  $C_s$  resonates with inductor  $L_r$  through the coupled transformer primary  $L_p$ , in the loop  $C_s - D_o - L_p - L_r - T$ , returning energy to the dc supply through the coupled secondary circuit. The primary voltage is  $V_s/N$ , and provided this referred voltage is less than a half  $V_s$ , all the energy on  $C_s$  is transferred to the dc supply via the transformer. The snubber diode  $D_s$  clamps the capacitor  $C_s$  voltage to zero, and excess energy in  $L_r$  is transferred to the dc supply, in the loop  $D_o - L_p - L_r - D_s$ , as the inductor  $L_r$  current falls linearly to zero when opposed by the referred dc link voltage via the transformer. In figure 10.12a, the secondary winding can be connected to the other terminal of  $C_s$ . Once the energy transfer is complete, the transformer core magnetising current resets to zero in the same Kirchhoff loop, but at a low voltage. Reset must be complete in one complete period of switch T.

### iii RC snubber recovery

The IGBT thyristor is commonly used and characterised with an RC snubber. The figure 10.6b shows how the snubber diode  $D_s$  in figure 10.6a can be replaced by a resistor to form an RC snubber, provided diode  $D_s$  is used to clamp the minimum snubber capacitor voltage to zero. The resistor losses are  $\frac{1}{2} C_s V_s^2$ . The snubber capacitor stored energy after turn-off,  $\frac{1}{2} C_s V_s^2$ , can be recovered at switch turn-on, provided the  $R_s C_s$  time constant is at least comparable with the LC resonant period – an unlikely condition.

### 10.2.2 Active recovery

#### i. Recovery into the dc supply

Active energy recovery methods for the turn-off snubber are simpler than the technique needed for active recovery of turn-on snubber circuit stored energy. This is because the energy to be recovered from the turn-off snubber is fixed at  $\frac{1}{2} C_s V_s^2$  and is independent of load current. In the case of the turn-on snubber, the energy to be recovered is load current magnitude dependent ( $\propto I_s^2$ ) which complicates active recovery. Active turn-off snubber energy recovery usually involves an intermediate capacitive energy storage stage involving a positive or negative voltage rail (with respect to the emitter of the principal switch).

#### a Negative intermediate voltage rail

At switch T turn-on the snubber capacitor stored energy is resonated into a large intermediate storage capacitor  $C_o$  as shown in figure 10.13a. Recovery from  $C_s$  to  $C_o$  at switch T turn-on occurs through the following loops:

at switch T turn-on when  $V_{C_s} > 0$ :  $T - C_o - L - D_a$  (as shown in figure 10.8a and equations (10.12) - (10.13))

then when  $V_{C_s} = 0$ :  $D_s - C_o - L - D_a$  (as shown in figure 10.8b and equation (10.14))

The switch current is increased by the resonant current, which has a maximum of  $V_{C_o} / \sqrt{L/C_s}$ . It is possible to use the energy in  $C_o$  as a negative low-voltage rail supply. This passive recovery technique suffers from the problem that the recovered energy  $\frac{1}{2} C_s V_s^2$  may represent more energy than the low-voltage supply requires. An independent buck-boost smps can convert excess energy stored in  $C_o$  to a more useful voltage level. Producing the gate drive for the smps switch  $T_{smps}$  presents few difficulties

since the gate-emitter has a low dc offset and does not experience any  $dv/dt$  relative to the emitter reference voltage of the main switch T.

The basic recovery circuit, with the buck-boost smps, can form the basis of an active turn-off snubber energy recovery circuit when switches are series connected, as considered in section 10.4.

It may be noticed that the 'Cuk' converter in chapter 19.6 is in fact the snubber energy recovery circuit in figure 10.13a, controlled in a different mode.

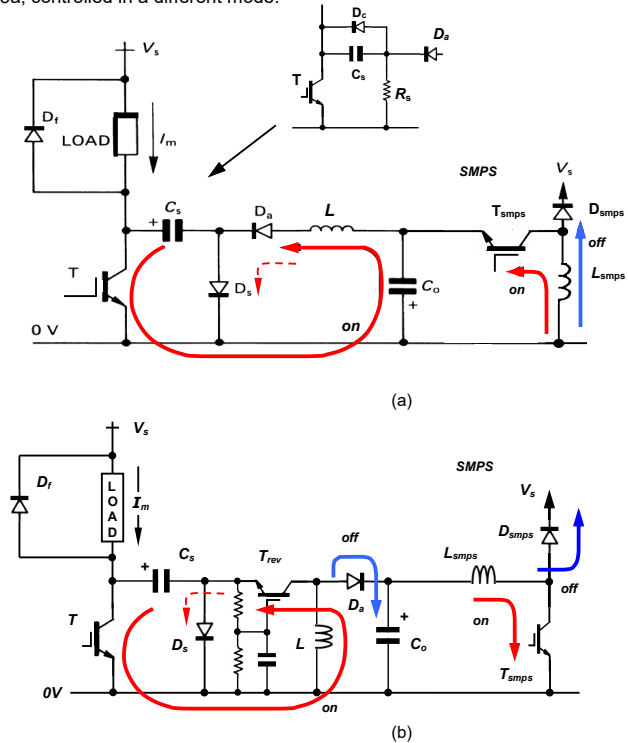

Figure 10.13. Switching circuit for recovering turn-off snubber capacitor energy, and for providing either (a) a negative voltage rail and/or transferring to  $V_{sv}$  via a buck-boost smps or (b) a positive voltage rail and/or transferring to  $V_{sv}$  via a boost smps.

#### b Positive intermediate voltage rail

A positive voltage source, with respect to the main switch emitter, can be produced with the recovery circuit in figure 10.13b. Practically, an extra switch,  $T_{rev}$ , is needed in order to minimise the time of current decay in the loop  $L - D_s$ , after the switch T is turned on and the voltage on the snubber capacitor  $C_s$  has resonated to zero. A passive resistor-capacitor network can be used to synchronise the turn-on (due to the main switch T turning on) and turn-off (due to diode  $D_s$  becoming forward biased) of the low-voltage switching device  $T_{rev}$ . Recovery from  $C_s$  to  $C_o$  at switch T turn-on occurs through the following Kirchhoff current loops:

at switch T turn-on when  $T_{rev}$  is on and  $V_{Cs} > 0$ :  $C_s - T - L - T_{rev}$ , for a period  $\frac{1}{2}\pi\sqrt{LC_s}$

then when  $T_{rev}$  is off and  $V_{Cs} = 0$ :  $C_o - L - D_s$  for a period  $V_s/\omega_o V_{C_o}$

A boost smps controls and transfers the energy on  $C_o$  to the dc rail through diode  $D_{smpls}$ .

The basic recovery circuit, with the boost smps, when cascade connected, can form the basis of an active turn-off snubber energy recovery circuit for series connected switches, as considered in 10.4.

#### ii. RC snubber recovery

The IGThyristor is commonly used and characterised with an R-C snubber (as opposed to a parallel connected series capacitor-diode turn-off snubber). The insert in figure 10.13a, for use in figures 10.13a and b, shows how the snubber diode  $D_s$  can be replaced by a resistor to form an R-C snubber, provided diode  $D_c$  is used to clamp the minimum snubber capacitor voltage to zero. The resistor losses are  $\frac{1}{2}C_s V^2$ . Most of the snubber capacitor stored energy after turn-off,  $\frac{1}{2}C_s V^2$  at switch turn-off, (depending

on the  $R_s - C_s$  time constant), can be recovered using either of the basic circuits in figure 10.13, or the circuits in figures 10.6 and 10.14, provided the  $R_s C_s$  time constant is greater than the LC resonant period.

Whether a positive or negative intermediate voltage is produced on  $C_o$ , (typically a few tens of volts, but much higher if part of a turn-on snubber recovery circuit), the energy on  $C_o$  is usually smps converted to stable gate voltage levels of the order of  $\pm 15V$ . Since a dual rail polarity gate level supply is needed, the polarity of the voltage on  $C_o$  (viz., positive or negative) is inconsequential.

### 10.3 Unified turn-on and turn-off snubber circuit energy recovery – single ended

#### 10.3.1 Passive recovery

Conventional inductive turn-on and capacitive turn-off snubber circuits can both be incorporated around a switching device as shown in figure 8.20 where the stored energy is dissipated as heat in the reset resistor. Figure 10.14 shows unified turn-on and turn-off snubber circuits which allow energy recovery from both the snubber capacitor  $C_s$  and inductor  $\ell_s$ .

#### i. Recovery into the load

The snubber capacitor energy is recovered by the transfer process outlined in section 10.2.1. Figure 10.14a shows the energy transfer (recovery) paths at switch turn-off. The capacitor  $C_o$  and inductor  $\ell_s$  transfer their stored energy to the load in parallel and simultaneously, such that the inductor voltage is clamped to the capacitor voltage  $V_{C_o}$ .

As  $C_o$  discharges, the voltage across  $\ell_s$  decreases to zero, at which time the load freewheel diode  $D_r$  conducts. Any remaining inductor energy is dissipated as unwanted heat in circuit resistance. Proper selection of  $\ell_s$  and  $C_s$  ( $\frac{1}{2}L_s I_m^2 \leq \frac{1}{2}C_s V_s^2$ ) can minimise the energy that is lost although all the snubber capacitor energy is recovered, neglecting diode and stray resistance losses. The energy (controlled by, and transferred to the turn-on snubber inductor  $\ell_s$ ) associated with freewheel diode reverse recovery current, is also recovered.

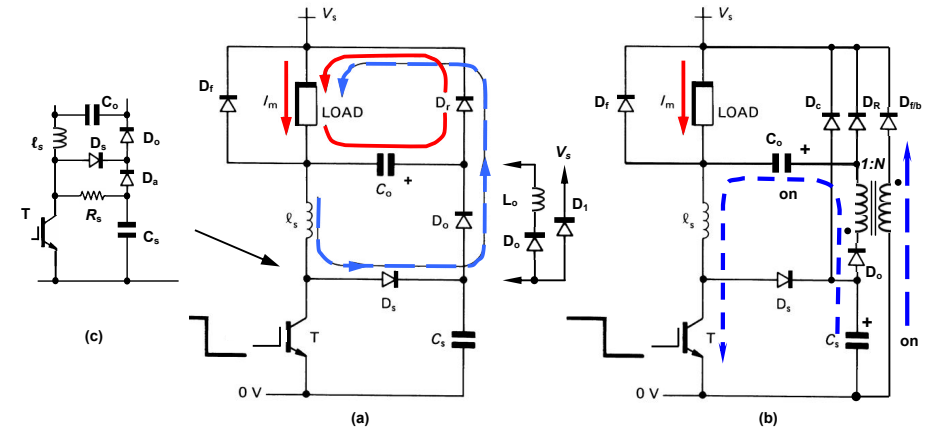

Figure 10.14. Switching circuits incorporating unified turn-on and turn-off snubber, showing recovery path of energy (a) in  $C_o$  and  $\ell_s$ ; (b) in  $C_s$  and  $\ell_s$  through  $D_r$ ; and (c) recovery circuit when an RC snubber is employed.

#### At switch turn-on

When the switch is off, the freewheel diode  $D_r$  conducts the load current  $I_m$ , capacitor voltage  $V_{C_s} = V_s$  and  $V_{C_o} = 0$ .

#### Phase one: $t_{p1}^{on}$

When the switch is turned on, the series inductor  $\ell_s$  performs the usual turn-on snubber function of controlling the switch  $di/dt$  according to (assuming the switch voltage fall time is relatively short)

$$i(t) = \frac{V_s}{\ell_s} t \quad (10.27)$$

The switch current rises linearly to the load current level  $I_m$  and then continues to a level  $I_{RR}$  higher as



the freewheel diode  $D_f$  recovers with currents in the paths shown in figure 10.15a. This diode reverse recovery current  $I_{RR}$  is included in the analysis since the associated energy transferred to the turn-on inductor is subsequently recovered.

The peak switch current  $I_m + I_{RR}$  is reached after the duration  $t_{p1}^{on}$

$$t_{p1}^{on} = (I_m + I_{RR}) \frac{\ell_s}{V_s} \quad (10.28)$$

As long as the freewheel-diode conducts, the load is clamped to near zero volts, thus  $C_s$  remains charged to  $V_s$ .

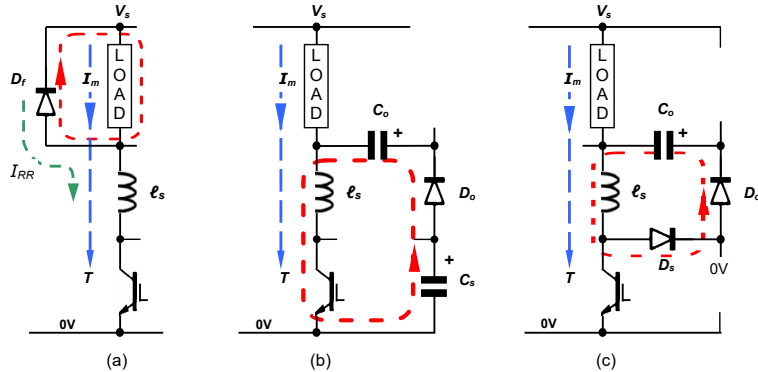

Figure 10.15. Unified turn-on and turn-off snubber at switch turn-on, showing (a) current build-up in  $\ell_s$ ; (b) energy resonant transfer from  $C_s$  to  $C_o$ ; and (c) energy transfer from  $\ell_s$  to  $C_o$  through  $D_s$ .

#### Phase two: $t_{p2}^{on}$

The turn-off snubber capacitor  $C_s$  charge resonates in the path  $C_s - D_o - C_o - \ell_s$  and through the switch T, as shown in figure 10.15b. The capacitor voltages and resonant current are given by ( $n = C_s / C_o$ )

$$i_{Cs}(\omega t) = i_{Co}(\omega t) = \frac{V_s}{Z} \sin \omega t + I_{RR} \cos \omega t \quad (10.29)$$

$$V_{Cs}(\omega t) = V_s \left( 1 - \frac{1}{1+n} (1 - \cos \omega t) \right) + \frac{\omega_o Z}{\omega} \frac{I_{RR}}{n} \sin \omega t \quad (10.30)$$

$$V_{Co}(\omega t) = V_s \frac{n}{1+n} (1 - \cos \omega t) + \frac{\omega_o Z}{\omega} I_{RR} \sin \omega t \quad (10.31)$$

$$\text{where } Z = \omega \ell_s = \frac{1}{\omega C_o} = Z_o \sqrt{\frac{n+1}{n}} \quad (\text{ohms}) \quad Z_o = \sqrt{\frac{\ell_s}{C_o}} \quad (\text{ohms}) \quad n = \frac{C_s}{C_o}$$

$$\omega = \omega_o \sqrt{\frac{n+1}{n}} \quad (\text{rad/s}) \quad \omega_o = \frac{1}{\sqrt{\ell_s C_o}} \quad (\text{rad/s})$$

The freewheel diode  $D_f$  voltage is

$$V_{Df}(\omega t) = V_s + V_{Co} - V_{Cs} = V_s (1 - \cos \omega t) + I_{RR} Z \sin \omega t \quad (10.32)$$

When the freewheel-diode current reaches its peak recovery level,  $I_{RR}$ , it is able to support a voltage which from equation (10.32) sinusoidally increases from zero. Specifically the freewheel-diode reverse bias  $V_{Df}$  is controlled such that zero voltage turn-off occurs resulting in low recovery power losses. Stray or inductance deliberately introduced in series with  $D_o$  (to decrease the resonant peak current given by equation (10.29), approximately  $V_s / Z$ ) produces a freewheel-diode recovery step voltage  $V_s \ell_s / (\ell_s + L_{stray})$ , where the step is always less than  $V_s$ .

The resonant period prematurely ends (since  $n < 1$ ) when the snubber capacitor  $C_s$  voltage reduces to zero and is clamped to zero by conduction of the snubber diode  $D_s$ , as shown in figure 10.15c. Assuming  $I_{RR} = 0$  (to obtain a tractable solution), equating equation (10.30) to zero yields the time for period 2,  $t_{p2}^{on}$ , that is

$$t_{p2}^{on} = \frac{\cos^{-1}(-n)}{\omega} \quad (10.33)$$

at which time

$$i_{Co}(t_{p2}^{on}) = \frac{V_s}{Z} (1 - n^2) \quad (10.34)$$

and

$$V_{Co}(t_{p2}^{on}) = nV_s \quad (10.35)$$

#### Phase three: $t_{p3}^{on}$

The remaining energy stored in  $\ell_s$  is resonantly transferred into  $C_o$  in the path  $D_o - C_o - \ell_s - D_s$ , with initial conditions given by equations (10.34) and (10.35), according to

$$V_{Co}(\omega_o t) = \sqrt{n} V_s \sin(\omega_o t + \phi) \quad (10.36)$$

and

$$i(\omega_o t) = \sqrt{n} \frac{V_s}{Z_o} \cos(\omega_o t + \phi) \quad (10.37)$$

The resonant current reaches zero and energy transfer to  $C_o$  is complete, after a period

$$t_{p3}^{on} = \frac{1/2\pi - \phi}{\omega_o} \quad (10.38)$$

If the diode reverse recovery energy is reintroduced, based on energy transfer balance, the final voltage on  $C_o$  is

$$V_{Co}(t_{p3}^{on}) = \sqrt{nV_s^2 + (Z_o I_{RR})^2} \quad (10.39)$$

The turn-on equations (10.29) to (10.37) are essentially the same as equations (10.11) to (10.14) for the turn-off snubber energy recovery circuit considered in section 10.2.1, except free-wheel diode reverse recovery has now been included. The circuit turn-on voltage and current waveforms shown in figure 10.9 are also applicable.

#### At switch turn-off

When the switch is on, it conducts the load current  $I_m$  and the snubber capacitor  $C_s$  voltage is zero, while the transfer capacitor voltage  $V_{Co}(t_{p3}^{on}) = \sqrt{n} V_s = V_o$  (neglecting the  $I_{RR}$  component) is a result of the previous switch turn-on. When the switch T is turned off, the collector current decreases linearly from  $I_m$  towards zero in time  $t_{ff}$ .

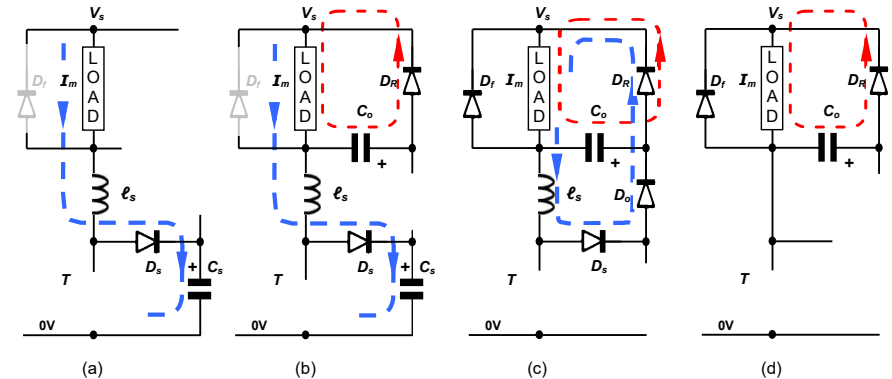

Figure 10.16. Unified turn-on and turn-off snubber at switch turn-off, showing (a) current diversion to snubber capacitor  $C_s$ ; (b) transfer capacitor  $C_o$  releasing energy (c) energy transfer to the load simultaneously from  $\ell_s$  and  $C_o$  through  $D_R$ ; and (d) energy transfer from  $C_o$  into the load through  $D_R$ .

#### Phase 1: $t_{p1}^{off}$

The load current is progressively diverted to the snubber capacitor as the collector current decreases, giving a capacitor (and collector) voltage of

$$v_{ce} = V_{Cs}(t) = \frac{1}{C_s} \int_0^t (I_m - i_c) dt = \frac{1}{C_s} \int_0^t I_m \frac{t}{t_{ff}} dt = \frac{I_m t^2}{C_s 2t_{ff}} \quad 0 \leq t \leq t_{ff} \quad (10.40)$$

If the collector current reaches zero before any other associated recovery processes occurs, then after the collector current has reached zero, the collector and snubber voltages rise linearly (being clamped in parallel), with currents in the paths shown in figure 10.16a, according to

$$V_{ce} = V_{Cs}(t) = \frac{1}{2} \frac{I_m t_f}{C_s} + \frac{I_m t}{C_s} \quad \text{provided} \quad \frac{1}{2} \frac{I_m t_f}{C_s} \leq V_s - V_o \quad (10.41)$$

The collector voltage reaches  $V_s$  at a time given from equation (10.41) when  $V_{Cs} = V_s - V_{Co}$  as

$$t_{p1}^{off} = \frac{C_s}{I_m} (V_s - V_o) + \frac{1}{2} t_f \quad (10.42)$$

where  $V_o$  is given by equation (10.39) and the period duration includes the collector linear fall period  $t_f$ .

### Phase 2: $t_{p2}^{off}$

When the collector (and snubber) voltage  $V_{Cs}$  reaches  $V_s - V_o$  capacitor  $C_o$  begins to discharge into the load providing the load current  $I_m$ . Simultaneously  $C_s$  charges to  $V_s$  through  $\ell_s$ , as shown in figure 10.16b. The relevant circuit capacitor voltages and current are

$$i_s(\omega t) = I_m \frac{n}{1+n} \left( 1 + \frac{1}{n} \cos \omega t \right) \quad (10.43)$$

$$V_{Cs}(\omega t) = I_m Z_o \frac{1}{n+1} \left( \frac{1}{\sqrt{n+1}} \sin \omega t + \omega_o t \right) + V_s - V_o \quad (10.44)$$

$$V_{Co}(\omega t) = I_m Z_o \frac{1}{n+1} \left( \frac{1}{\sqrt{n+1}} \sin \omega t - \omega_o t \right) + V_o \quad (10.45)$$

This phase is complete when the snubber capacitor  $C_s$  is charged to the supply voltage,  $V_s$ , assuming the inductor current is greater than zero at that time. Let the inductor current be  $I_2$  at the end of the off-period  $t_{p2}^{off}$  and the capacitor  $C_o$  voltage be  $V_2$ .

### Phase 3: $t_{p3}^{off}$

The snubber capacitor is clamped to the rail voltage. The transfer capacitor  $C_o$  and snubber inductor  $\ell_s$  both release energy in parallel into the load through the paths shown in figure 10.16c. The inductor voltage is clamped to the capacitor  $C_o$  voltage. The snubber inductor current is

$$i_s(\omega_o t) = I_m + \frac{V_2}{Z_o} \sin \omega_o t + (I_2 - I_m) \cos \omega_o t \quad (10.46)$$

while the transfer capacitor voltage is

$$V_{Co}(\omega_o t) = V_2 \cos \omega_o t + Z_o (I_2 - I_m) \sin \omega_o t \quad (10.47)$$

One of two conditions form the completion of this phase

- the transfer capacitor voltage reaches zero before the snubber inductor current reaches zero
- the snubber inductor current reaches zero before the transfer capacitor voltage reaches zero

The **first** condition represents the case where the remaining inductor current associated energy is lost as it freewheels to zero in the low voltage path  $\ell_s - D_o - D_R$  and the load.

In the **second** case, the inductor current given by equation (10.46) reaches zero, while the transfer capacitor  $C_o$  continues to discharge into the load as shown in figure 10.16d. The inductor current is prevented from reversing by diode  $D_s$ . Once the inductor current has fallen to zero, the transfer capacitor voltage falls linearly to zero as it provides the load current  $I_m$ . This second case represents the situation when 100% of all snubber (inductor  $\ell_s$  and capacitor  $C_s$ ) and diode reverse recovery energy is recovered, that is

$$\frac{1}{2} \ell_s (I_m + I_{RR})^2 \leq \frac{1}{2} C_s V_s^2 \quad (10.48)$$

Snubber reset and recovery is complete when the snubber inductor current and transfer capacitor voltage are both zero, the collector voltage has ramped to  $V_s$ , and the free-diode conducts the full load current  $I_m$ . From equation (10.47), this stage is complete when  $V_{Co}(t_{p3}^{off}) = 0$ , that is

$$t_{p3}^{off} = \frac{1}{\omega_o} \tan^{-1} \left( \frac{V_2}{Z_o (I_2 - I_m)} \right) \quad (10.49)$$

Now the switch can be turned on.

### ii. RC-L dual snubber recovery

The IGBT thyristor is commonly used and characterised with an RC snubber and an inductive turn-on snubber. Figure 10.14c shows how the snubber diode  $D_s$  in figure 10.14a can be replaced by a resistor to form an RC snubber, provided diode combination  $D_a - D_s$  is used to clamp the minimum snubber

capacitor voltage to zero. The resistor losses are  $\frac{1}{2} C_s V_s^2$ . The snubber capacitor stored energy after turn-off,  $\frac{1}{2} C_s V_s^2$ , can be recovered at switch turn-on, while the inductive turn-on energy  $\frac{1}{2} L_s I_s^2$  is recovered at switch turn-off, provided the  $R_s C_s$  time constant is greater than the LC resonant period.

### iii. Recovery into the load and supply

Figure 10.14b shows a dual snubber energy recovery technique where a portion of the resonance energy is transferred back to the dc supply (as opposed to the load) at switch turn-on, through a magnetically coupled circuit where it is required of the turns ratio that  $N > 2$ . This reduces the energy transferred from the snubbers to the load, giving better load regulation under light load conditions. Load regulation with light loads is poor since the snubber capacitor energy is fixed,  $\frac{1}{2} C_s V_s^2$ , independent of the load,  $I_m$ . In the analysis to follow, the recovery contribution of freewheel diode reverse recovery energy is neglected.

#### At switch turn-on

The turn-on phase is essentially the same as the circuit considered in figure 10.14a, except the transformer is seen as an opposing emf voltage source  $V_s/N$ .

#### Phase one: $t_{p1}^{on}$

The switch current fall period is described by equation (10.27) and the time of the first turn-on period is given by equation (10.28).

#### Phase two: $t_{p2}^{on}$

The equations (10.29) to (10.35) are modified to account for the transformer referred voltage  $V_s/N$

$$i_s(\omega t) = i_{Cs}(\omega t) = i_{Co}(\omega t) = \frac{N-1}{N} \times \frac{V_s}{Z} \sin \omega t \quad (10.50)$$

$$V_{Cs}(\omega t) = V_s \times \frac{1}{N(1+n)} \times [1 + Nn + (N-1) \cos \omega t] \quad (10.51)$$

$$V_{Co}(\omega t) = V_s \frac{n(N-1)}{N(n+1)} (1 - \cos \omega t) \quad (10.52)$$

The instantaneous power being returned to the supply through the transformer is given by

$$p(\omega t) = \frac{V_s}{N} \times i_s(\omega t) = \frac{V_s}{N} \times \frac{N-1}{N} \times \frac{V_s}{Z} \sin \omega t = \frac{N-1}{N^2} \times \frac{V_s^2}{Z} \sin \omega t \quad (10.53)$$

The time for this period is given by equation (10.51), when the snubber capacitor voltage is zero

$$t_{p2}^{on} = \frac{1}{\omega} \times \cos^{-1} \left( -\frac{nN+1}{N-1} \right) \quad (10.54)$$

The energy returned to the supply is

$$W_{Trans}(t_{p2}^{on}) = \frac{n+1}{N} \times \frac{V_s^2}{\omega Z} = \frac{1}{N} \times C_s V_s^2 < \frac{1}{2} C_s V_s^2 \quad \text{since } N > 2 \quad (J) \quad (10.55)$$

#### Phase three: $t_{p3}^{on}$

Energy continues to be recovered back into the supply  $V_s$  through the transformer when the resonant current transfers to the diode  $D_s$ . Capacitor  $C_s$  charges to  $V_s$  and is clamped to  $V_s$  by diode  $D_c$ .

The final voltage on the transfer capacitor  $C_o$  is

$$V_{Co}(t_{p3}^{on}) = \frac{V_s}{N} \left[ \sqrt{1 + nN^2} - 1 \right] \quad (10.56)$$

The total energy transferred to the supply through the transformer is the difference between the initial energy in  $\ell_s$  and  $C_s$  and the final energy in  $C_o$ .

$$W_{Trans}(t_{p2}^{on} + t_{p3}^{on}) = \frac{1}{2} C_s V_s^2 + \frac{1}{2} \ell_s I_m^2 - \frac{1}{2} C_o \frac{V_s^2}{N^2} \left[ \sqrt{1 + nN^2} - 1 \right]^2 \quad (10.57)$$

If the turn-on inductor current reaches zero before the third phase can commence (due to  $N$  being too small), then the turn-off snubber does not fully discharge, and will act as a soft clamp in the subsequent switch turn-off cycle. The capacitors retain the following voltages

$$V_{Cs} = V_s \frac{2 + Nn - N}{N(n-1)} = V_s - \frac{2}{N(n-1)} V_s \quad (10.58)$$

$$V_{Co} = V_s \frac{2n(N-1)}{N(n+1)} \quad (10.59)$$



**At switch turn-off**

The circuit recovery operation at turn-off is essentially the same as when no transformer is used ( $N \rightarrow \infty$ ), except that the voltage on  $C_o$  at the begin of turn-off is given by equation (10.59) or equation (10.56), as appropriate.

**Operating regions of the dual energy recovery circuits**

Both the passive unified recovery circuits analysed can be assessed simultaneously for their operational bounds, since the bounds for the transformerless version in figure 10.14a are obtained by setting  $N$  to infinitely in the appropriate equations for the recovery circuit in figure 10.14b. Figure 10.17 shows various operational boundaries for the two unified passive energy recovery circuits analysed. The various boundaries are determined from the operating equations for the circuits.

The boundaries in figure 10.17a show the regions of full snubbing and for soft snubbing where the capacitor  $C_s$  is not reset to zero voltage during the resonant cycles at turn-on. The boundaries are summarised as follows

$$n < \frac{N-2}{N} \tag{10.60}$$

$$n < \frac{N}{N-2} \tag{10.61}$$

The boundaries in parts b and d of figure 10.17 satisfy equation (10.57), namely the capacitor energy is less than the inductor energy. The current is normalised with respect to  $\sqrt{nV_s/Z_o}$ . Part d shows that the relative range for 100% recovery, defined as  $(\hat{I} - \bar{I})/\hat{I}$ , is independent of the transformer turns ratio.

Figure 10.17c shows the normalised (with respect to  $2\pi\sqrt{n/\omega_o}$ ) reset time at turn-off. The reset time at turn-on is the sum of periods one and two, but is dominated by the second turn-on period, namely

$$\check{t}_{on} = \frac{1}{\omega} \cos^{-1}(-n) \tag{10.62}$$

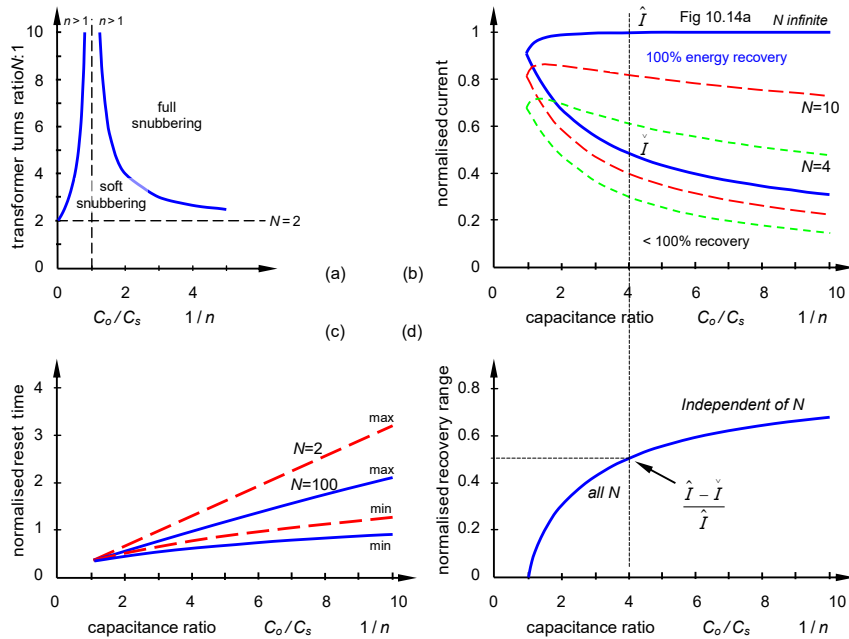

Figure 10.17. Unified, passive snubbing characteristics: (a) operating regions with recovery transformer; (b) 100% recovery regions with different transformer turns ratios; (c) normalised circuit reset limits; and (d) normalised recovery range independent of transformer turns ratio.

**10.3.2 Active recovery**

**i. Recovery into the dc supply**

Both turn-on and turn-off snubber energy can be recovered into the dc supply using a dedicated buck-boost smps formed by  $T_{smps}$ ,  $D_{smps}$  and  $L_{smps}$ , shown in figure 10.18. Both snubbers (capacitor  $C_s$  and inductor  $L_s$ ) transfer their energy to the intermediated storage capacitor,  $C_o$ , from which the energy is smps transferred to the dc supply  $V_s$ . The buck-boost smps also maintains a fixed voltage on  $C_o$ , which facilitates rapid energy transfer of the turn-on snubber inductor  $L_s$  energy to  $C_o$  at switch T turn-off, in time  $L_s I_m / V_{C_o}$ . The maximum switch off-state voltage is  $V_s + V_{C_o}$ . At switch T turn-on, the turn-off snubber capacitor  $C_s$  energy is resonated to  $C_o$  through the loop  $C_s - T - C_o - L_s - D_o$ , as considered in detail in section 10.3.1. The smps is operated in a discontinuous inductor current mode in order to minimise smps switch and diode losses and stresses. The maximum smps switch and diode voltages are  $V_s + V_{C_o}$ . Figures 10.18b and c show circuit versions with a reduced component count. With the inductor  $\ell$  removed, the resonant reset current magnitude and period is now only controlled by the turn-on snubber inductor. A further diode can be removed as shown in figure 10.18c, but the number of series components in the turn-on inductor reset path is increase as is the loop inductance associated with the path.

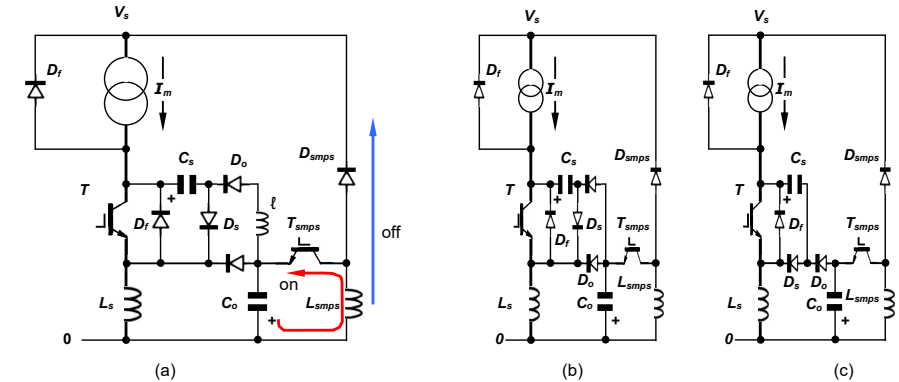

Figure 10.18. Unified, active turn-on and turn-off snubber energy recovery circuits: (a) basic circuit and (b) and (c) reduced component variations.

**10.4 Inverter bridge legs**

Capacitive turn-off snubbers (without any turn-on snubber circuit inductance), both active and passive are not normally viable on bridge legs because of unwanted capacitor discharging and subsequent uncontrolled charging current, as considered in chapter 9.4. At best capacitive soft turn-off voltage clamps (operational at  $>V_s$ ) can be employed to reduce turn-off losses, as shown in figure 9.24.

**10.4.1 Turn-on snubbers**

**i. Active recovery - recovery into the dc supply**

Figure 10.19 shows inverter bridge legs where both switches benefit from inductor turn-on snubbers and active energy recovery circuits. The circuits also recover the energy associated with freewheel diode reverse recovery current. The turn-on energy and diode recovery energies are both recovered back into the dc supply,  $V_s$ , via a buck-boost smps. At switch turn-off, the energy stored in  $L_s$  is transferred to capacitor  $C_o$  via diode  $D_s$ .

For given turn-on snubber inductance  $L_s$ , both circuits give the same  $di/dt$  in the switches. The capacitor voltages determine the snubber reset time. When both circuits result in the same switch maximum voltages, the reset times are the same. But the capacitor voltages in figure 10.19a are half those for the circuit in figure 10.19b. The main operational difference between the two configurations is the periods when the capacitors are charged. In figure 10.19a, both capacitors are charged at both switch turn-on and turn-off. In figure 10.19b, each capacitor is charged once per cycle, one capacitor is charged at turn-on, the other at turn-off.

Coupling of the turn-on inductors results in virtual identical waveforms as to when the inductors are not magnetically coupled. No net energy savings or gains result. Close coupling is therefore not necessary.

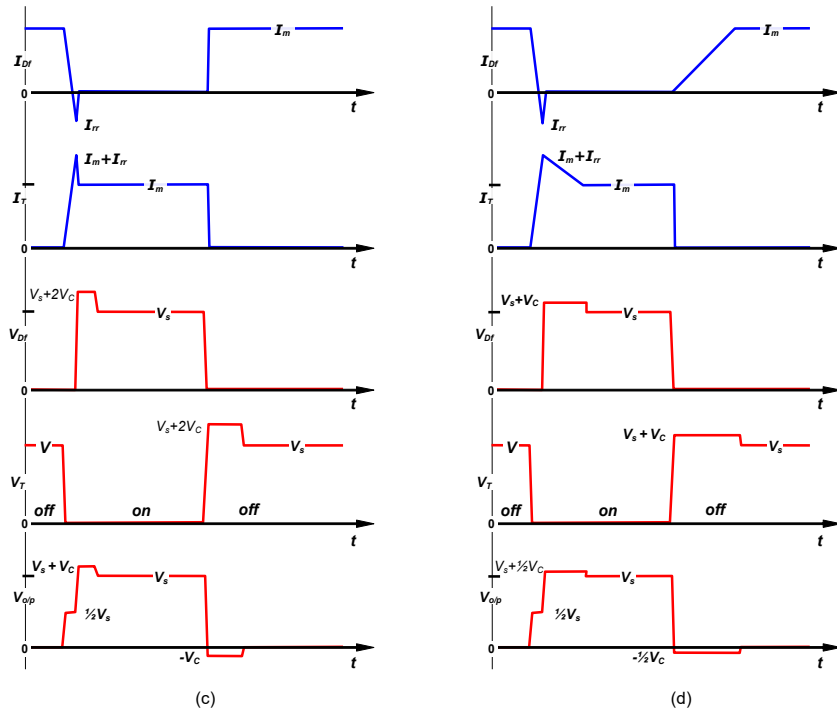
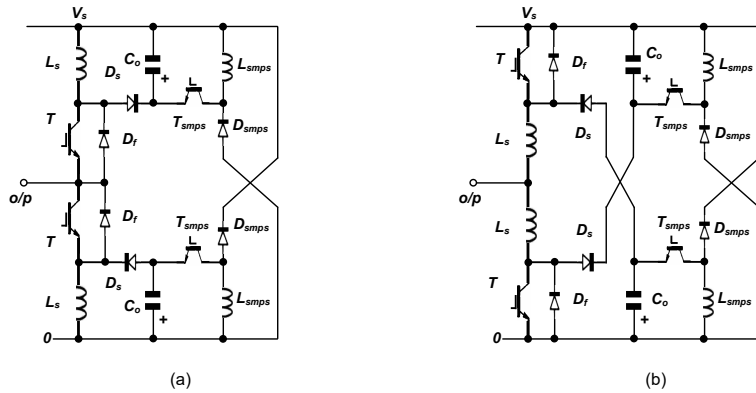

Figure 10.19. Active inductive turn-on snubber energy recovery circuits: (a) multiple single-ended circuit; (b) cross-coupled high frequency circuit; and (c) and (d) respectively circuit waveforms.

10.4.2 Turn-on and turn-off snubbers

i. Passive recovery - recovery into the dc supply

Figure 10.20 shows an inverter bridge leg where both switches have inductor turn-on and capacitor turn-off snubbers and passive energy recovery circuits. The circuit also recovers the energy associated with freewheel diode reverse recovery current. Both the turn-on energy and turn-off energy are recovered back into the dc supply,  $V_s$ . Although this decreases the energy transfer efficiency, recovery into the load gives poor regulation at low load current levels where the capacitor turn-off energy, which is fixed, may exceed the load requirements. Energy recovery involves a coupled magnetic circuit which can

induce high voltage stresses across semiconductor devices. Such conditions can be readily avoided if a split capacitor (multilevel) voltage rail, fed from multiple secondaries, is used, as shown in figure 10.2c. Dual snubber (inductor and capacitor) energy recovery occurs as follows. For switch S1, the turn-off snubber is formed by  $C_{s1}$  and  $D_{s1}$ , and the turn-on snubber comprises  $L_{s1}$ .

1. The energy stored in  $C_{s1}$  is resonantly transferred to  $C_{o1}$  when switch S1 is switched on, in the path  $C_{s1} - D_{t1} - C_{o1} - L_{s2} - L_{s1} - S1$ .
2. The energy stored on  $C_{o1}$  is resonantly transferred to the dc supply  $V_s$  through transformer T1 when switch S1 is turned off and (after an underlap period) S2 is turned on (in the path  $C_{o1} - L_{r1} - T1 - S2$ ).
3. When S2 is turned on, the turn-on snubber inductor  $L_{s1}$  releases its energy in parallel with capacitor  $C_{o1}$  (in the path  $L_{s1} - D_{s1} - D_{t1} - L_{r1} - T1 - S2 - L_{s2}$ ).
4. The diode  $D_{r1}$  prevents (by clamping) the transfer capacitor  $C_{o1}$  from reverse charging, by providing an alternate path for the remaining energy in the resonant inductor  $L_{r1}$  to be returned to  $V_s$  via the coupling transformer T1.
5. The transformer T1 magnetising current is also returned to the dc supply  $V_s$ , thereby magnetically resetting the coupling transformer T1.

The numerical subscripts '1' and '2' are interchanged when considering the recovery processes associated with switch S2.

The recovery circuit can operate at switching frequencies far in excess of those applicable to the IGCThyristor and the high power IGBT. The limiting operational factor tends to be associated with the various snubber reset periods which specify the switch minimum on and off times. Although adequate for IGCThyristor requirements, minimum on and off times are a restriction to the IGBT.

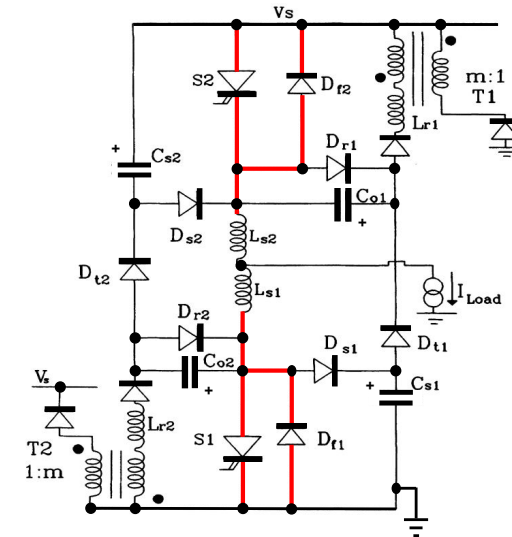

Figure 10.20. Unified, passive snubber energy recovery circuits for GTO and GCT inverter bridge legs.

ii. Active recovery - recovery into the dc supply

Figure 10.21 shows two similar turn-on and turn-off snubber, active energy recovery circuits, which are particularly suitable for bridge leg configurations. In figure 10.21a, the turn-on snubber section is similar in operation to that shown in figure 10.4 while the turn-off snubber section is similar in operation to that shown in figure 10.13a. A common buck-boost smps is used for each turn-on and turn-off snubber pair. This arrangement is particularly useful when the two power switches and associated freewheel diodes are available in a single isolated module package. The active recovery circuit in figure 10.21b shows the inductive turn-on snubbers relocated. The buck-boost smps inputs are cross-coupled, serving the turn-on snubber of one switch and the turn-off snubber of the other switch.

The interaction of turn-off snubbers in both circuits can create high  $L$ - $C$  resonant currents as discussed in section 8.4. In each case, two buck-boost smps and intermediate storage capacitors  $C_o$  can serve numerous bridge legs, as in a three-phase inverter bridge.

Theoretically the recovery smps diodes  $D_r$  can be series connected, thereby eliminating a diode, as shown in figure 10.21c. But to do so assumes the two inductor recovery currents are both synchronised and equal in magnitude. Extra diodes,  $D_i$  are needed to divert any inductor current magnitude imbalance, as shown in figure 10.21c, which negates the diode saving in having series connected the recovery diodes  $D_r$ . Alternatively, the single inductor recovery circuit in figure 10.21d may be used provided the smps switches are not conducting simultaneously. Synchronisation of the smps switch to its associated main switch avoids such simultaneous operation. The recovery circuits in figure 10.21 parts c and d are applicable to both the bridge leg circuits in figure 10.21 parts a and b.

The circuit in figure 10.21a is readily reduced for single-ended operation, as shown in figure 10.18.

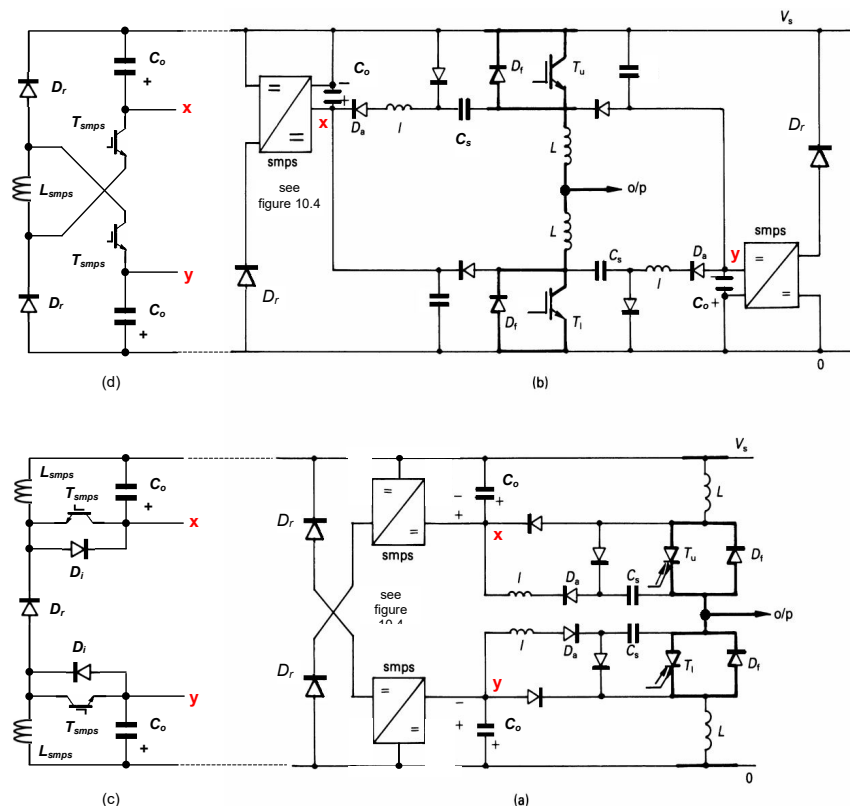

Figure 10.21. Unified, active snubber energy recovery circuits: (a) multiple single-ended circuit; (b) cross-coupled high frequency circuit; and (c) and (d) coupled smps variations.

## 10.5 Snubbers for multi-level inverters

The multi-level inverter introduced in Chapter 17.3 utilises series connected switching elements with each switch operated in a voltage clamped mode. Three multi-level inverter configurations are commonly presented

- the diode clamped multi-level inverter – see figure 17.34
- the flying capacitor clamped multi-level inverter – see figure 17.36 and
- the cascaded H-bridge multi-level inverter – see figure 17.37

### 10.5.1 Snubbers for the cascaded H-bridge multi-level inverter

Since the cascade multilevel inverter (see figure 17.37) is comprised of identical H-bridge modules, any of the snubbers for bridge legs considered in section 10.4 are applicable. Snubbers can be active or passive, incorporating only an inductive turn-on snubber or a capacitive soft turn-off snubber or both turn-on and turn-off snubbers. When the cascaded H-bridge approach is used for three-phase VAR compensation, real power must be returned to the ac system if the recovered energy is in excess of the inverter losses.

### 10.5.2 Snubbers for the diode-clamped multi-level inverter

Various snubbers have been proposed for the neutral point clamped inverter which involves a split dc rail composed of two series connected capacitors, as shown in figure 17.34. Generally devices are asymmetrically stressed or indirectly snubbed. Indirect snubbing approaches should be avoided since the main problem with high power multilevel inverters is the decoupling of circuit inductance. For levels higher than three, only the outer switches have a fixed dc reference, viz., 0V or  $V_{dc}$ , hence recovery circuits on these switches can return energy to the outer link capacitors. Energy recovery from snubbers on the inner switches is hampered by the clamping diodes. Thus recovery of snubber energy in a three-level inverter is viable since the two link capacitors are in fact two outer capacitors, referenced to the dc rails. Recovery must be into the associated level capacitor of a given switch, if recovery circuit component voltage ratings are to be limited to that of the main switching elements.

### 10.5.3 Snubbers for the flying-capacitor clamped multi-level inverter

Turn-off snubbers for the flying capacitor clamped inverter are problematic since the switch clamping principle is based on indirect clamping and the level clamping capacitors support multiple-voltages in excess of the individual device operating voltage ratings. As seen in figure 17.36, the flying capacitors associated with inner switches support lower voltages than the outer capacitors.

As a general rule, if snubbing is being considered, then a series connection approach as in section 10.6 is viable, provided device switching delays are minimised. The turn-off delay of the GCThyristor can be reduced to less than 400ns if high  $di/dt$  reverse gate current drive is employed. The key limitation in reverting to series connected device operation is the loss of amplitude modulation offered by multi-level circuits. As a consequence, series connected devices produce higher output  $dv/dt$  voltages. The neutral point clamped inverter with series connected devices is a favoured medium voltage compromise.

## 10.6 Snubbers for series connected devices

Two basic approaches are adopted when power-switching devices are series connected in order to operate circuits at voltages in excess of individual device voltage ratings.

- Use a multilevel structure as considered in Chapter 17.3, where individual switches are effectively soft clamped or
- series connect devices with fast turn-on and turn-off, minimising device switching delays thereby improving transient voltage sharing; possibly using simple  $R$ - $C$  snubbers

The use of turn-on and turn-off snubbers greatly increases system complexity and size but does offer a method for reliably operating series connected devices, a modular structure, and the possibility of obtaining gate drive power for individual series connected cells. Fast, noise free, isolated uni/bidirectional signal transmission, without any isolation or  $dv/dt$  problems, to virtual any voltage potential is possible with fibre optics. The production of isolated gate drive supply power at tens, possibly hundreds of kilovolts is problematic. The usual approach for deriving emitter level supplies involves tapping energy from static voltage sharing resistors, resulting in high resistor losses, or tapping energy from the  $R$ - $C$  snubber during switching transitions. Both methods do not provide fail-safe device operation (in the off-state, with static  $dv/dt$  capability) at the initial application of the HV dc link voltage. The use of inductive and capacitive switching snubbers offers two advantages, other than enforcing transient voltage sharing of series connected devices, which may mitigate the associated increased cost and complexity

- better device  $I$ - $V$  utilisation and a higher switching frequency
- the derivation of cell level gate power supplies from snubber recovered energy

Many of the previously presented active snubber energy recovery circuits in this chapter are directly transferable to multilevel inverter configurations, thereby extending the current and frequency capabilities of the main switching devices, particularly the GCThyristor, and freewheel diodes. Once

snubbers are employed, traditional series device connection with snubbers is simpler than a multilevel approach, but does not offer the multilevel output voltage features (amplitude modulation and reduced  $dv/dt$ ) of multi-level inverter configurations.

The snubber recovered energy is usually far in excess of that that can be utilised for gate drive power. The topological nature of series connected devices precludes any form of relatively simple snubber energy recovery (active or passive) other than recovery back into the dc link supply.

### 10.6.1 Turn-off snubber circuit, active energy recovery for series connected devices

#### i. Recovery into the dc supply

Series connection of switches and diodes requires static voltage sharing (resistors) and transient voltage sharing circuitry, viz., capacitive turn-off snubbers for voltage sharing during turn-off and inductive turn-on snubbers for voltage sharing during turn-on. Figure 10.22 shows series connected devices, each modular cell level incorporating a main switch and inverse parallel connected freewheel diode, plus a turn-off snubber  $C_s - D_s$ , a resonant circuit  $L - D_o$ , an intermediate energy storage capacitor  $C_o$ , and buck-boost smps recovery circuitry  $T_{smpls} - L_{smpls} - D_{smpls}$ , as shown in figure 10.13a and considered in 10.2.2. The recovery smps is operated so as to maintain a near constant voltage on the intermediate storage capacitor  $C_o$ . The cell energy recovery switches  $T_{smpls}$  are synchronised, all being turned on up to the switch minimum on-time (immediately before the switches  $T$  are turned off), and turned off when the main switches  $T$  are turned off. The timing sequence for the control signal, switch  $T$  and recovery switch  $T_{smpls}$  is shown in figure 10.22b. Note that the transmitted control signal is truncated at the switch  $T$  turn-off edge, by the switch minimum on-time,  $t_{delay}$ , which is approximately  $\frac{1}{2}\pi\sqrt{LC_s}$ .

When  $T_{smpls}$  are turned off, the inductive stored energy in each  $L_{smpls}$  is returned to the dc link through each corresponding diode  $D_{smpls}$  as shown in figure 10.22a. Any imbalance in the individual inductor current magnitudes, involves currents in excess of the minimum of all the inductor currents being diverted to the cell snubber capacitor  $C_s$  through  $D_{smpls} - C_s - D_s - L_{smpls}$ . The inductor recovery current differentials are minimal compared to the principal current in the switches, hence do not unduly affect capacitive turn-off snubber charging, hence transient turn-off voltage balancing action.

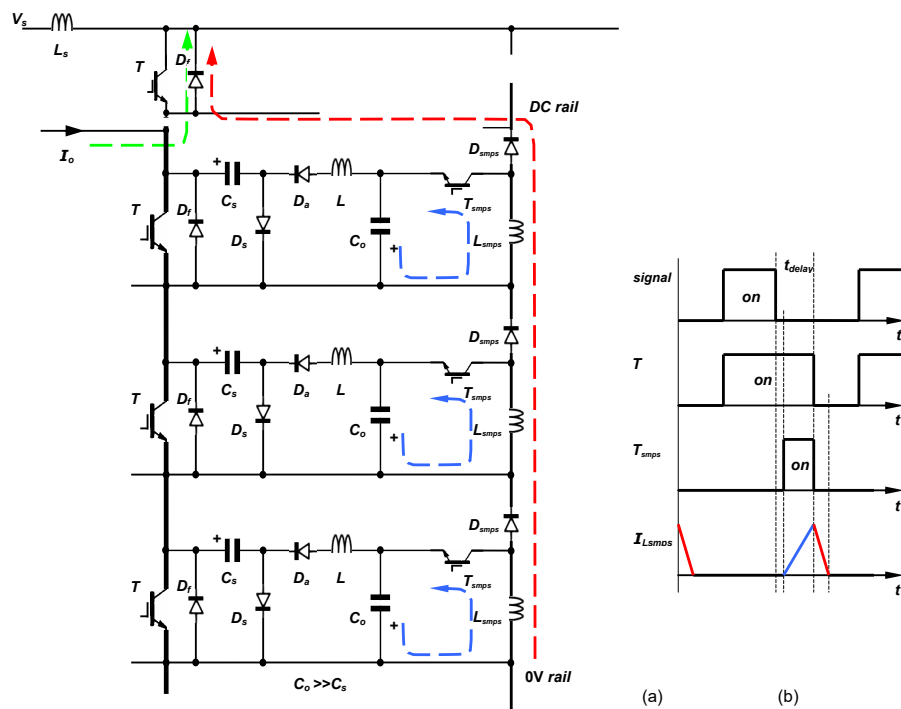

Figure 10.22. Active turn-off snubber energy recovery for series GCT connected, inverter bridge legs: (a) modular cell circuit and (b) timing diagram.

The turn-on snubber  $L_s$  in figure 10.22 is indirectly clamped, with the stored energy released into the series string of turn-off snubber capacitors. Link inductance is mandatory in order to control recharging of the turn-off snubber capacitor as considered in section 9.4.

Although the smps switch  $T_{smpls}$  and diode  $D_{smpls}$  are high voltage devices, rated at the cell voltage level, both are not particularly stressed during energy recovery switching, since the recovery buck-boost smps are operated in a discontinuous inductor current mode. The switch  $T_{smpls}$  turns on with zero current, without any diode reverse recovery effects, while diode  $D_{smpls}$  suffers minimal reverse recovery, since its principal current reduces to zero controlled by  $L_{smpls}$ , with recovery  $di/dt$  current (or voltage) controlled (or supported) by the smps inductors  $L_{smpls}$ . A static voltage-sharing resistor across each cell (not shown in figure 10.22) compensates for various static voltage and current imbalance conditions on both the main switch  $T$  and smps diode  $D_{smpls}$  network, particular during converter start-up and shutdown sequencing.

#### System start-up

The intermediate transfer stage capacitor  $C_o$  can be used to provide a source of gate level power, via a dedicated smps. One of two start-up sequences are used to build-up gate power and cell voltages before normal switching operation can commence. In both cases, an ac to dc single or three phase half-controlled converter is used to ramp charge the intermediate capacitor  $C_o$  associated with the lowest potential cell (typically  $C_o$  operates at about 50V to 100V). This capacitor  $C_o$  in turn provides gate power, via a dedicate 100V dc to  $\pm 15Vdc$  smps, for the lowest level switch  $T$ . By using series blocking/directing diodes, rated at the cell voltage rating, one ac to dc converter can supply the lowest potential cell of all bridge legs, as shown in figure 10.23a. Proprietary pre-charging sequences are used to charge  $C_o$  on higher cell levels, depending on whether the dc link voltage is established or not. As each  $C_o$  is progressively charged, its associated gate supply smps is self-activated, enabling external control of that switching cell. Inverter start-up can involve the application of the dc link voltage before gate level power has been established. This does not present a problem for GCThrystors, but in the case of the IGBT, a low passive impedance gate to emitter circuit is needed to avoid inadvertent device turn-on due to Miller capacitor  $dv/dt$  effects.

#### (a) Start-up with an established dc link voltage

In the case of an inverter with an established dc link voltage, each level switch, hence cell, supports half its normal operating voltage, and each snubber capacitor  $C_s$  is charged to the cell voltage level. All the intermediate energy storage capacitors  $C_o$  are discharged, except for the lowest potential cell capacitor, which has been ramp charged by the ac to dc converter. The recovery smps (and main switch) of the lowest potential cell is operable.  $T_{smpls}$  of the lowest potential cell is turned on, then off and the current in the associated  $L_{smpls}$  tends to overcharge  $C_s$  of the lowest potential cell. This forces current to increase through the  $C_o - L - D_s$  combinations of the higher potential cells as each  $C_s$  is forced to decrease its charge, therein charging higher-level capacitors  $C_o$ . The voltage on  $C_s$  of the lowest potential cell can be doubled before the cell reaches its normal operating voltage level. Thus for  $n$  series connected cells, the operating limit of the intermediate capacitor  $C_o$  voltage satisfies  $(n-1)V_{C_o} < 2V_s/n$ . That is, any smps sourcing from  $C_o$  used to provide gate supply voltage rails for the main switch  $T$ , must be able to function (convert) down to a voltage level satisfied by this inequality equation.

When a cell voltage reaches its operating voltage limit, the associated main switch is turned on briefly to resonantly discharge the snubber capacitor  $C_s$ . The supported voltage is redistributed among the other cells, which typically, are only supporting half the normal cell operating voltage.

#### (b) Start-up with no pre-existing dc link voltage

In the case where the dc link voltage has not been established, a similar charging process is used as for the case of a pre-existing dc link voltage. The dc link capacitance must be on the inverter side of the isolation. The dc link capacitor is initially charged through series diodes  $D_s$  to the maximum cell voltage as capacitor  $C_s$  of the lowest potential cell is parallel charged from  $C_o$  by its associated recovery smps. The lowest potential recovery smps is commutated numerous times in order to charge the dc link capacitance which is usually significantly larger in capacitance than  $C_s$ . Once the link capacitor is charged to the maximum allowable cell voltage, the main switch  $T$  of the lowest potential cell is turned on to reset its associated snubber  $C_s$  voltage to zero. The start-up mechanism used with a pre-existing dc link voltage can then be used. Once  $C_o$  in each cell is charged sufficiently to enable its gate voltage smps to become operational, synchronised use of the recovery smps at each level allows charging of the dc link capacitor to the operational voltage level (in fact slightly in excess of the rectified peak level). Then the vacuum circuit breakers before the rectifier, feeding the series connected device circuit, can be closed, which results in zero line current in-rush.

Connection of the load and an interfacing filter may be problematic without dedicated contactors, as is the influence of the output filter on the cell charging mechanism previously outlined.

#### Other gate power derivation methods

Gate power derived from switching recovered energy cannot be maintained during prolonged standby periods. Using dropper resistors (as for static voltage sharing) to provide all gate level power

requirements results in high dissipation losses, particularly during continuous standby periods (that is, 100% dissipation duty cycle). Although resistors are used for steady-state series voltage sharing, the current associated with this mechanism ( $\approx 10\text{mA}$ , depending of the degree of device matching and operating temperature range) is well below that needed for gate power ( $\approx 50\text{W}$  for IGBTs and much less for IGBTs). But this level of sharing resistor current ( $\approx 10\text{mA}$ ) may be sufficient to trickle maintain gate level supplies of cells in the off-state during prolong standby periods, using variations of the circuits shown in figure 10.23c.

Depending on the load and output filter, it may be possible during prolong standby periods to sequence the inverter between 000 and 111 states, thereby producing zero average voltage output between phases but activating the snubbers hence resonant recovery circuits that charge each  $C_o$ .

Provided sufficient switch voltage redundancy is available, sequential bootstrapping is possible where each level is boot strapped supplied from the immediate next lower level, as shown in figure 10.23b. (See figure 8.4). In the case of a positive voltage as shown in figure 10.23b, each switch, starting from the lowest level is sequentially turned on and off, thereby transferring gate energy from the lowest level to the highest level. (An expanding repetitive simultaneous on-state sequence is used, progressively involving higher potential cells.) This approach is viable in single-ended series connected switch applications. Although each bootstrap diode  $D_{bs}$  is rated at the cell level voltage, in the case of inverter legs, only half the inverter leg devices can be supplied, since any bootstrap diode bridging the pole centre take-off node must be rated at the full dc link voltage (actually  $\frac{1}{2}n-1$  levels can be charged since the lowest level cell is not bootstrapped).

If the bootstrapping voltage is referenced with respect to the high potential terminal of the cell, then the supply voltage on  $C_o$  is bootstrap by transferring energy from the highest potential cell down to the lowest potential cell.

A similar approach can be used with transformer isolated smps's transferring power between adjacent levels, which need only be rated at the cell level voltage. Again, this approach is viable in single-ended applications, but in the case of inverter legs, the pole output take-off node cannot be readily bridged by an smps because of the high dc link voltage blocking and isolation requirement. Also, each smps experiences  $dv/dt$  stresses when the level switches are commutated.

Possibly the simplest and most reliable method to derive gate power in series connected circuits, up to a few 100kV, is to use ac current transformers with series connected single-turn primaries, where each level short-circuits the secondary when not charging.

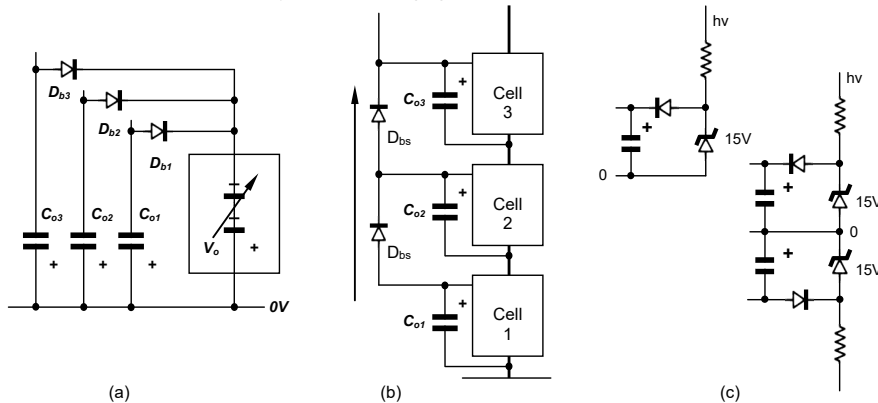

Figure 10.23. Gate supply derivation methods: (a) ac to dc half-controlled converter for ramp pre-charging of all lowest leg level capacitors  $C_o$ ; (b) bootstrapping a positive voltage supply; and (c) Zener diode based sources using static voltage sharing resistors or/and R-C snubber resistors.

### 10.6.2 Turn-on snubber circuit active energy recovery for series connected devices

#### i. Recovery into the dc supply

An active energy recovery, inductive turn-on snubber as shown in figure 10.4 (usually with an R-C turn-off snubber), can be adapted and used at each series cell level, therein providing gate level power possibilities from  $C_o$  and energy recovery through series connect buck-boost smps recovery circuitry, as shown in figure 10.24a. The capacitor  $C_o$  is configured to be connected to the emitter of switch  $T_{smps}$ . Energy stored in the turn-on snubber inductor  $L_s$  is transferred to the intermediate storage capacitor  $C_o$  via diode  $D_s$  at switch  $T$  turn-off. The switching sequence is shown in figure 10.24b. Each recovery smps

maintains the voltage near constant on its associated  $C_o$  and the higher this voltage the faster the inductor  $L_s$  current is linearly reset to zero, in time  $t_{reset} = L_s I_m / V_{C_o}$ . Excess energy on  $C_o$  is transfer (recovered) to the dc link by synchronised switching of  $T_{smps}$ . Mismatched inductor  $L_{smps}$  current magnitudes and durations are diverted to charge  $C_o$  of any cell attempting to recover a lower current magnitude, by turning off all  $T_{smps}$  just before all the main switches  $T$  are turned off, as shown in figure 10.24b. This balancing effect is minimal (but does eliminate any smps diode forward recovery effects) and any current imbalance subsequently tends to overcharge the output capacitance of the main switch of the cells with recovery current in excess of the minimum of all the smps recovery currents. Some form of turn-off snubbing is therefore necessary in order to avoid excessive main switch  $T$  voltages at turn-off.

The voltage rating of the various cell circuit semiconductors is increased by the voltage on  $C_o$ . A cell static voltage sharing resistor helps maintain steady-state voltage balance of both the main switch  $T$  and the smps diode  $D_{smps}$ .

#### a Start-up

One ac to dc converter can be used to pre-charge each lowest level capacitor  $C_o$  of each inverter leg, as shown in figure 10.23a, provided the path to each inverter leg incorporates a series blocking/directing diode, rated at the cell voltage level. The start-up sequence, using the lowest level smps to charge higher level  $C_o$  and the dc link to the sum of all  $C_o$  voltages, is straightforward. Synchronised operation of all the smps can then gradually fully charge the dc rail, if it is not already pre-charged.

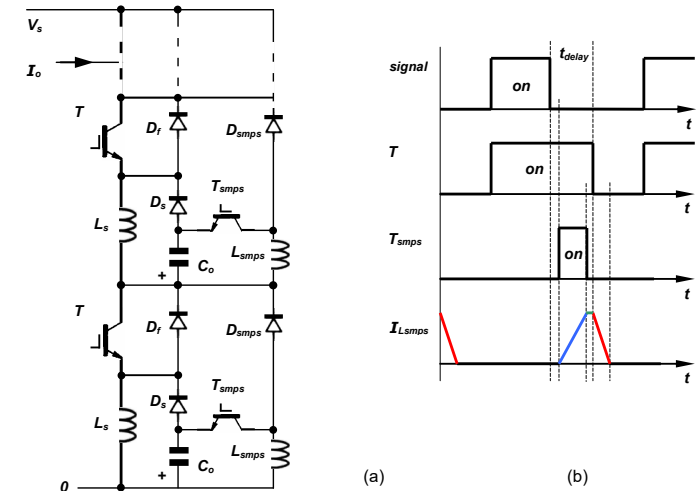

Figure 10.24. Active turn-on snubber energy recovery for series GCT connected, inverter bridge legs: (a) modular cell circuit and (b) timing diagram.

### 10.6.3 Turn-on and turn-off snubber circuit active energy recovery for series connected devices

#### i. Recovery into the dc supply

If a single inductive turn-on snubber  $L_s$  is used in the dc link as in figure 10.22a, its stored inductor energy at switch turn-off is transferred to the capacitive turn-off snubbers of cells supporting off-state voltage. During switching, this causes voltage ringing between the cells and the link inductor. This inductor is rated at the full dc link voltage and cannot be clamped by the usual resistor-diode parallel connected reset circuit as in figure 9.19a. This is because any reset components (R-D) need high voltage ratings – in excess of the dc link voltage during diode  $D_r$  reverse recovery. For this reason, an inductor snubber (possibly saturable) may be used at each cell level, giving a complete modular cell structure. Active snubber energy recovery of both inductive and capacitive energy is possible, although it may be convenient to resistively dissipated the turn-on inductive snubber energy, which is load current dependant,  $\frac{1}{2}L_s I^2$ .



Dual, unified active snubber energy recovery can be achieved by using the recovery circuits shown in figure 10.21b, but with the smps diodes series connected as shown in figure 10.25a. For a modular cell structure, all the cells are configured as for the lower switch in figure 10.21a. This switch configuration is preferred since capacitor  $C_o$  can be readily pre-charged to initiate the start-up sequence for charging higher level  $C_o$ , which can be used to derive gate level power for the associated cell. A relatively low voltage on capacitor  $C_o$  (if  $C_o$  operates at about 5 to 10% of the cell operating voltage) may necessitate a long switch T minimum off-time in order to ensure reset of the turn-on inductor current to zero. This is not a problem for GTO type devices which have minimum on and off time limitations. Higher operating voltages for  $C_o$  necessitate a more complicated smps to derive gate level power for switch T. At higher cell operating voltages, the intermediate storage capacitor  $C_o$  can be modified to the circuit in figure 10.25b. The low voltage output  $lv$  can be used to power cell start-up circuitry.

The resonance inductor  $\ell$  (in series with the turn-on snubber inductance  $L_s$ ) is used to control the magnitude and duration of the resonant period of  $C_s$  transferring its charge to  $C_o$ . The minimum value of inductor  $\ell$  can be zero if  $L_s$  is large enough to satisfactorily control resonant reset circuit conditions without  $\ell$ . A further simplification can be made by removing a resonant circuit diode as shown in figure 10.25c, which is derived from the circuits in figure 10.18.

The timing sequence in figure 10.22b for turn-off snubbers is used.

One functional design constraint should be observed. At switch turn-on, current builds up in  $L_{smps}$  because of the voltage on  $L_s$ , during the later part of the cycle when  $C_s$  resonates its charge to  $C_o$ . This relatively small current magnitude linearly increases to a magnitude dependant on the relative magnitudes of  $L_s$  to  $\ell$  and  $L_{smps}$ , and the magnitude of the voltage retained on  $C_o$ . Once established, a near constant, slowly decreasing current flows in a zero voltage loop,  $L_{smps} - D_{smps} - T - L_s$ , and is recovered during recovery smps action at switch turn-off.

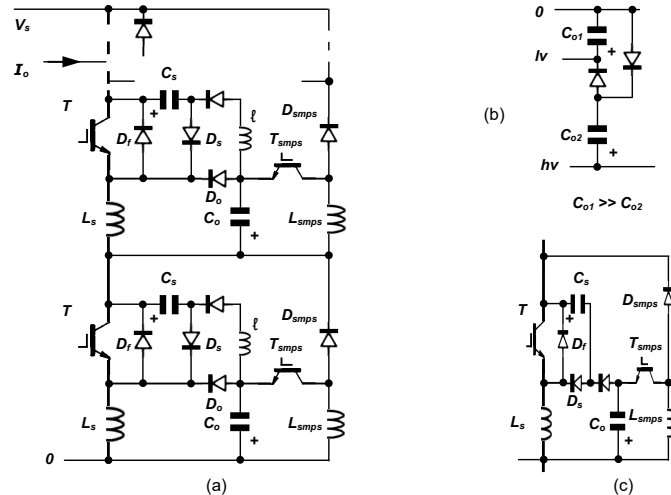

Figure 10.25. Active turn-on and turn-off snubber energy recovery: (a) circuit for series GCT and IGBT inverter bridge legs; (b) high voltage replacement circuit for  $C_{o1}$  and (c) reduced component variation of part a.

#### (a) Start-up

The capacitor  $C_o$  of the lowest potential cell (in each bridge leg) is negatively ramp charged by a dedicated ac to dc converter as shown in figure 10.23a. This establishes cell internally generated gate supply power and hence external control of both switches of the lowest potential cell.

The recovery smps of the lowest potential cell is operated in a discontinuous mode, which charges up the turn-off snubber capacitor  $C_s$  of that cell. Simultaneously current flows in three other parallel paths, tending to charge up the dc link capacitor, viz.

- the series connected  $L_{smps} - D_{smps}$
- the series connected  $L_s - D_f$
- the series connected  $C_o - D_o - D_f$

Thus provided the smps of the lowest cell delivers a high current, each  $C_o$  receives charge before the current is diverted and built up in inductors  $L_{smps}$  and  $L_s$ . The dc link capacitor simultaneously receives charge. The switch  $T_{smps}$  on-time, hence its current, is not restricted during the start-up procedure. Once

gate power, hence external control is established on each cell, judicious operation of each smps and main switch T can facilitate charging of the dc link capacitor and contains all cell voltages to within the rated cell voltage.

The start up mechanism may necessitate a suitable diode connected in series or anti-parallel with  $T_{smps}$ .

#### (b) Shut down

After the dc link has been isolated, under zero inverter output current conditions, using a vacuum circuit breaker on the ac side, the intermediate capacitor of the lowest potential cell (in each bridge leg) is maintained in a partially discharged state by a resistive load which is switch connected to the capacitor  $C_o$  of the lowest potential cell. The auxiliary ac to dc converter used to initially charge  $C_o$  is disabled during normal operation and shut-down, with all the ac to dc converter thyristors off, therefore blocking current in both directions. Alternatively, if this ac to dc converter has suitable two quadrant operational modes, then the energy continually being transferred to  $C_o$  from other cells, can be recovered into the low voltage ac source. The various smps and main switches are operated so as to maintain equal voltage across all cells (by sequentially commutating each main switch on then off), gradually decreasing the dc link voltage as energy is continually, but controlled, being transferred to and removed from the lowest potential cell capacitor  $C_o$ .

#### 10.6.4 General active recovery concepts for series connected devices

In each of the three snubber circuits considered for series connected devices, the common key recovery mechanism is performed by a buck-boost smps, with components rated at the cell voltage level.

Figure 10.26 shows two basic underlying recovery techniques for transferring energy from  $C_o$  through an inductor, into the dc supply at a higher potential. The key difference between the two techniques is the polarity orientation of the energy source  $C_o$  and the dc supply  $V_s$ , with respect to their common node.

- Figure 10.26 parts a and b show boost converters, where energy is drawn from  $C_o$  when energy is being delivered to the supply  $V_s$ , via an inductor.
- Figure 10.26 parts c and d show buck-boost converters, which do not involve  $C_o$  during the period when energy is being delivered to the supply  $V_s$ , via an inductor.

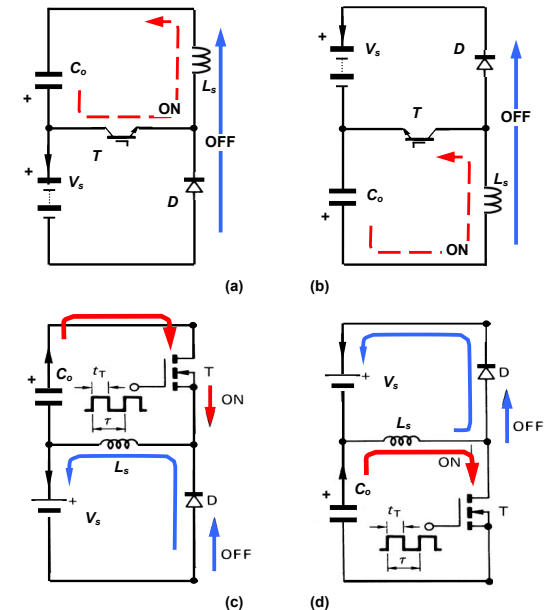

Figure 10.26. Underlying energy recovery circuits when energy in  $C_o$  is stored at different potentials: (a) and (b) boost smps recovery and (c) and (d) buck-boost smps recovery.

A common requirement is that an smps output (whether inductor-diode for buck-boost and inductor-diode- $C_o$  for boost) span a cell, thereby inherently interconnecting in series any number of cells. Each

intermediate storage capacitor  $C_o$  must therefore be connected to one cell terminal. To confine further the possibilities, it is unlikely that  $C_o$  referenced with respect to the cell collector will yield a useful active recovery circuit. If the capacitor  $C_o$  is referenced with respect to the switch collector/anode,  $C_o$  undergoes high  $dv/dt$  voltages with respect to the switch gate. This complicates any smps using the stored capacitor  $C_o$  energy for gate drive purposes. The polarity orientation of  $C_o$  and the recovery smps components are therefore restricted to the four possibilities shown in figure 10.27. Series recovery assumes the smps inductors conduct an identical instantaneous maximum magnitude and same duration current.

#### (a) Start up

The general cell structures and their recovery smps can inherently be used to charge other series connected cells and the dc link, and to provide a dc source (the intermediate storage capacitor  $C_o$ ) from which to derive cell level power supplies for the gate level circuitry. Specific proprietary switching sequences are required at start-up, depending on the cell circuit arrangement, the output filter and load, the dc link and ac rectifier input arrangement and initial conditions.

#### (b) Shut down

At shut down, once the inverter is in standby, the dc link supply is isolated (by opening the ac side vacuum circuit breakers) under zero current conditions, then the dc link voltage is cyclically discharged into the load via the series connected cells. Such link discharge using cell switching sequences is problematic when

- each cell voltage reaches a level where  $C_o$  falls below a level to maintain operation of the smps used to provide gate level voltage which allows the cell switches to operate; or
- cells in another inverter legs cease to operate sooner.

Such limitations are mitigated by ensuring the smps that operates across  $C_o$  has a wide (low minimum bounds) input voltage operating range.

If the load is isolated at shut down, then the dc link energy can be sequentially transferred to  $C_o$  of the lowest potential cell in each leg and dissipated in a single ended resistive dumping circuit or recovery from  $C_o$  via the ac to dc converter (fully controlled) used during the start-up sequence, as shown in figure 10.23a. The sequence involves progressively, but sequentially, not using higher-level recovery smps.

Fail-safe start-up and shut down sequencing, so as not to over-volt any cell, usually require cell operational coordination. The fibre optic communications link for cell level on/off control of the main switch T, is therefore bidirectional.

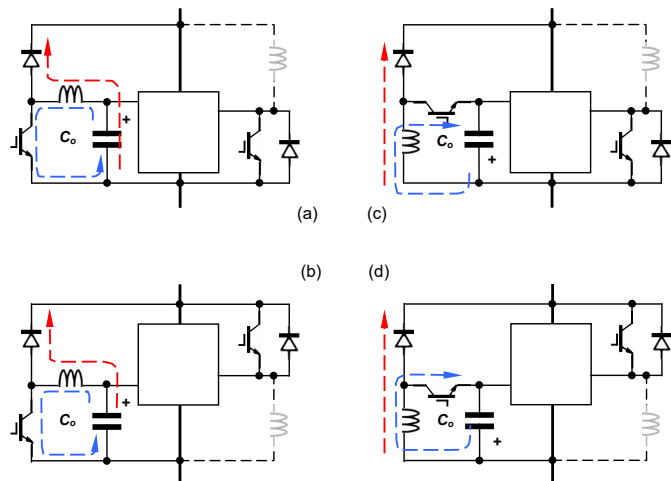

Figure 10.27. Cell active energy recovery from  $C_o$  with: (a) and (b) a boost converter and (c) and (d) a buck-boost converter.

#### 10.6.5 Soft clamping turn-off snubbers with turn-on snubber, for series connected devices

The modular multilevel converter, MMC, presented in 17.3.4, can be used in a two level mode that facilitates turn-off soft voltage sharing and clamping of over-voltage due to the energy released from the

(voltage mismatch) inductors  $L$  in figure 10.28. In high voltage applications, the series inductance  $L$  can be distributed within the cells. The clamping capacitors  $C_i$  are significantly smaller than when used to generate multilevel voltage waveforms, conducting the load current for significant periods, in the standard MMC. There purpose in figure 10.28 is to consecutively but temporarily support voltage and load current for a few microseconds thereby giving a two level output voltage but stepped to control the output voltage  $dv/dt$ . In this mode, unlike the modular multilevel converter, no dc component or second order positive and negative sequence harmonics exist in the bridge leg or arms, which increase losses. Consequently the series inductance is significantly smaller than that necessary for the standard MMC and practical stray inductance levels may suffice. The capacitor voltages are balanced just as for the standard MMC and the auxiliary switches  $S_x$  and diodes  $D_x$  are rated for microsecond transient performance. The step dwell times need not be equal, if used to eliminate high order harmonics. Since clamping operation depends on bidirectional current  $I_y$ , the concept is not applicable to dc and low frequency output currents.

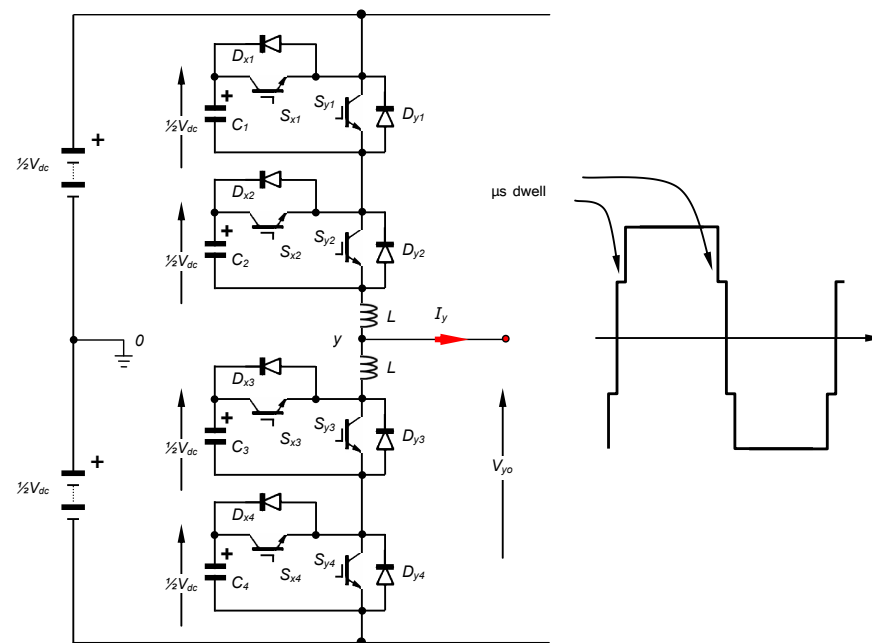

Figure 10.28. Series cell active energy recovery with turn-on snubber and switch voltage clamping, based on the MMC converter.

#### 10.7 Snubber energy recovery for magnetically-coupled based switching circuits

Coupled circuits can induced circuit and in particular switch voltages that exceed the supply voltage. These increased voltages are associated with two factors:

- leakage or uncoupled inductance energy release
- time-displaced energy-transfer coupled-circuits, as with the buck-boost converter or coupled voltages as with push-pull centre tapped transformer circuits

Both factors come into operation with the two buck-boost isolated output converters shown in figure 10.29. When energy is drawn by the coupled circuit secondary, a voltage is induced into the primary, increasing the voltage experience by the switch in the off-state. Energy associated with leakage inductance further increases the switch T voltage. If a basic R-C-D turn-off snubber is used, the capacitor stored energy is increased from  $\frac{1}{2}C_s V_s^2$ , if the switch voltage were to be limited to  $V_s$ , to in excess of  $\frac{1}{2}C_s (V_s + V_o/N)^2$ , where  $N$  is the transformer turns ratio as defined in figure 10.29. The leakage energy adds to the voltage component.



### 10.7.1 Passive recovery

Figure 10.29a shows a passive turn-off snubber energy recovery configuration for an isolated buck-boost converter. It is based on the circuit in figure 10.34j, where the transformer leakage inductance,  $L_l$ , is effectively the turn-on snubber inductance.

When the switch T is turned off, the snubber capacitor  $C_s$  charges from  $-V_s$  to a voltage  $v_o/N$ , controlled by the leakage inductance  $L_l$  which causes the capacitor  $C_s$  to charge to a higher voltage. Turn-off capacitor  $C_s$  snubbing of the switch is achieved indirectly, through the dc supply  $V_s$ .

At switch T turn-on, the charge on  $C_s$  resonates in the loop  $C_s$ -T- $L_l$ - $D_r$ , reversing the polarity of the charge on  $C_s$ . This reverse voltage is clamped to  $V_s$ , as the diode  $D_s$  conducts and the remaining energy in  $L_s$  is transferred (recovered) to the dc supply  $V_s$ . The switch minimum on-time is  $\frac{1}{2}\pi\sqrt{L_l C_s} = \frac{1}{2}\pi / \omega_o$ , whilst the energy recovered from  $L_l$  to  $V_s$  occurs independent of the state of the switch.

At switch T turn-off, after snubber capacitor  $C_s$  is fully charged, an oscillation can occur through  $L_l$ - $D_r$ - $C_s$  and the transformer primary back into the supply  $V_s$ . Although a lossless oscillation, it can effect the output voltage regulation, increase output rectifier recovery losses, but can be prevented by using a series switch in the  $L_l$ - $D_r$  path as shown in figure 10.29d. Then recovery occurs during switch T on-period, back into the supply  $V_s$ , without affecting the output regulation. Once a switch has been used, other active recovery possibilities may be more attractive.

The same leakage voltage control and recovery technique can be used on the push-pull converter in figure 10.29c, where two recovery circuits are used.

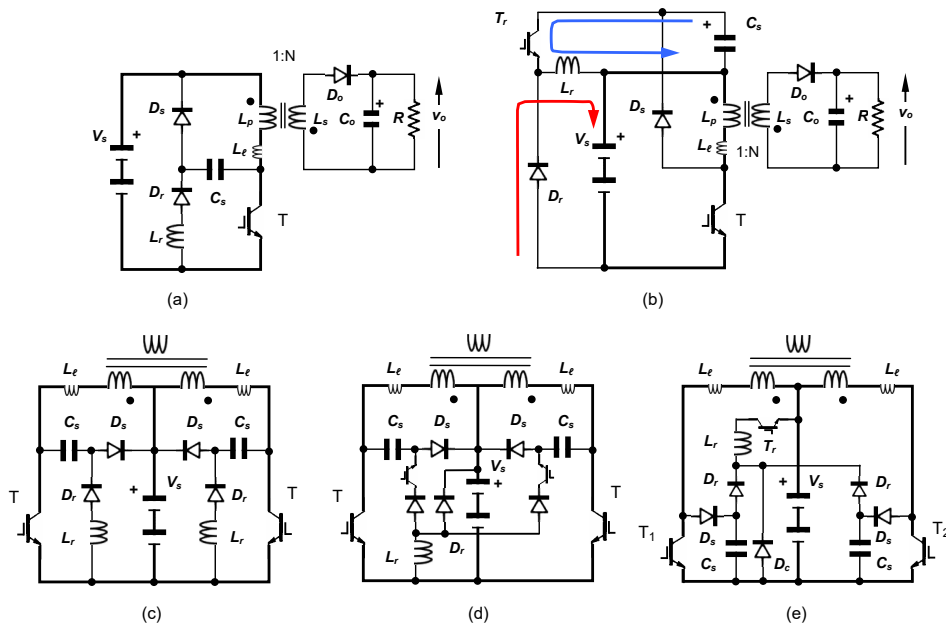

Figure 10.29. Recovery of leakage inductance energy: (a) and (c) passive and (b) (d) and (e) active recovery.

### 10.7.2 Active recovery

Figure 10.29b show the circuit of an active turn-off soft snubber energy recovery configuration.

Coupled circuit leakage inductance  $L_l$  energy is transferred to the intermediate storage capacitor  $C_s$  via  $D_s$  at switch turn-off. The voltage on  $C_s$  is maintained at a voltage related to  $v_o/N$  by the buck-boost smps formed by  $T_r$ ,  $L_r$  and  $D_r$ , which returns leakage energy to the dc supply  $V_s$ . The circuit function is to clamp the switch voltage rather than to perform a turn-off snubber action.

The maximum switch voltage is near constant, where as the voltage experience by the switch at turn-off in figure 10.29a, although variable, is snubbed, but dependant of the output voltage  $v_o$ . In both circuits, an R-C snubber may be required across the switch T since the recovery snubber circuits do not decouple stray inductance not associated with the coupled magnetic circuit.

Similar active snubber or clamping circuits can be used with push-pull converters which utilise a centre-tapped transformer (or autotransformer), as in figure 10.29d, where, with a full-wave rectified forward converter secondary circuit, the overvoltage is independent of the transformer turns ratio. The recovery circuit switches prevent undesirable lossless oscillations after main switch turn-off, particularly when the switch duty cycle is less than 50%. The diode  $D_r$  in figure 10.29d allows the active recovery switches to be activated with the same control signal timing as the corresponding main switch T, provided the switch minimum on-time is  $\geq \frac{1}{2}\pi\sqrt{L_l C_s}$ . The active recovery in 10.29e, requires only one reset inductor  $L_r$ .

### 10.7.3 Transformer leakage passive recovery

All transformers have leakage inductance. The leakage inductance of a transformer driven from an H-bridge can be utilised as a turn-on snubber, producing turn-on zero voltage switching ZVS conditions, which eliminate both switch turn-on losses and diode reverse recovery current injection problems. A consequence of ZVS is purely capacitive snubbers (no snubber diode or reset resistor) also become lossless. The sequence of circuit diagrams in figure 10.30 illustrate how the transformer leakage inductance is used to achieve ZVS.

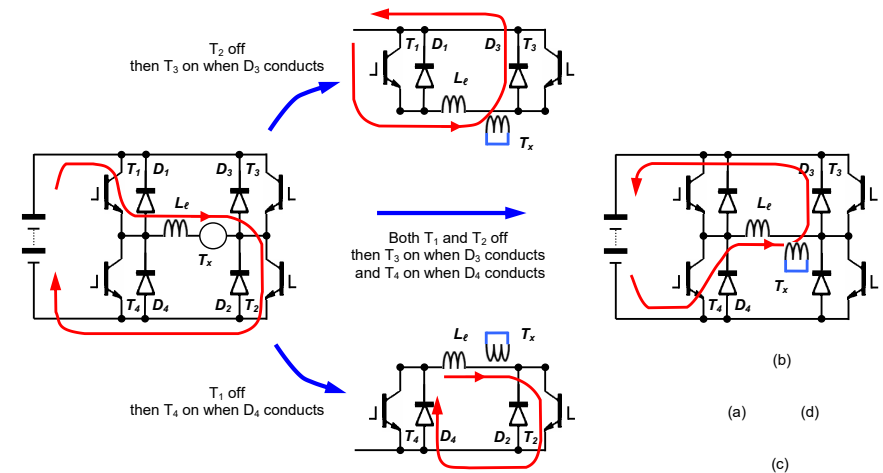

Figure 10.30. H-bridge current conduction paths: (a) switches  $T_1$  and  $T_2$  conducting; (b) switch  $T_2$  off and then  $T_3$  on; (c) switch  $T_1$  off and then  $T_4$  on; and (d) switches  $T_1$  and  $T_2$  off, then  $T_3$  and  $T_4$  on.

When any switch that is conducting current is turned off, current associated with the leakage inductance diverts to a diode, as shown in the off-loops in figures 10.30 parts b, c, and d. The switch in anti-parallel with that conducting diode in figure 10.30 can be turned on (at zero voltage), while the diode conducts, without any switch turn-on losses, ZVS. The zero volt loops, figures 10.30 b and c, are alternated for low duty cycles. At a maximum duty cycle, the negative voltage sequence in figure 10.30d is used, where the leakage inductance current falls rapidly to zero.

An inherent consequence of ZVS is that lossless capacitive turn-off snubbers (solely capacitors, without any resistive reset circuit) can be employed across each bridge switch. If the dc link is well decoupled only one snubber capacitor across either switch per leg is needed.

## 10.8 General passive snubber energy recovery concepts for single-ended circuits

Snubbers are used for stress reduction at

- switch turn-on - involving series inductance
- switch turn-off - involving shunt capacitance
- freewheel diode recovery - involving series inductance and/or shunt capacitance

and the snubber may incorporate more than one of these stress arresting functions.

A single ended switching circuit usually incorporates a switch  $T$ , a freewheel diode  $D_f$  and an inductive load, where the load may be configured to be in

- the emitter/cathode circuit of  $T$  or
- the collector/anode circuit of  $T$ .

The input energy source, the switch, diode and load may be configured to perform any of the following functions

- forward converter
- buck converter
- boost converter or
- buck-boost converter

The differentiation between the forward converter and the buck converter is that the inductive element is part of the active load in the case of the forward converter.

Figure 10.32a shows a switch-diode and inductor circuit combination, assuming a collector load circuit, which can be configured as any type of converter viz., forward, buck, boost, etc. Equivalent emitter load circuits, as well as collector loadings, are shown in figures 10.32 and 10.34, which present systematically a more complete range of circuit possibilities, in each case, with the same functional snubber circuit (the same ac equivalent circuit – since a snubber is a transient functional circuit).

Energy recovery into the load is usually associated with a parallel connected capacitor discharging (since an instantaneous change in capacitor current to match the load current is possible) while recovery back into the source is usually associated with a parallel connected inductor or magnetically coupled circuit releasing its energy (since an instantaneous change in inductor terminal voltage to equal the supply voltage is possible).

AC and dc circuit theory allows all these circuit configuration combinations to be generalised. This is because a snubber is an ac circuit – performing a transient function - while the source and load tend to be dc components (constant voltage and constant current sources respectively). Therefore it is possible to interchange the connections of the snubber (an ac circuit) with the connections to the dc voltage source, since ac-wise, a dc source appears as a short circuit. The snubber function can be achieved directly (across the switch) or indirectly (assuming a well decoupled supply).

An operational mechanism to be appreciated is the topological relative orientation within the principal circuit of the turn-on snubber inductor or turn-off snubber capacitor.

#### Turn-off snubber - capacitor:

Circuits in figure 10.32c and d show the turn-off snubber  $D_s - C_s$  combination parallel to the switch (direct snubbing) or alternatively connected across the freewheel diode to the dc rail (indirect snubbing). AC circuit wise these are the same connection since the dc source can be considered as a short circuit at high frequency. When  $D_s - C_s$  are parallel connected to the switch (direct snubbing), the capacitor charges as the switch voltage rises at turn-off, while in the case of the snubber being across the freewheel diode (indirect snubbing), the capacitor discharges, and by Kirchhoff's voltage law, the switch voltage is indirectly controlled to be the difference between the capacitor voltage and the source voltage. Practically it is preferred to place the  $D_s - C_s$  snubber directly across the element to be protected, the switch, since the source may not be well decoupled.

#### Turn-on and diode reverse recovery snubber - inductor:

Circuits in figure 10.32a and b show the inductor  $L$  configured such that the snubber turn-on inductor is in series with the switch (direct snubbing) or alternatively in series with the freewheel diode (indirect snubbing). Both arrangements perform the same function at switch turn-on. Assuming a constant current in the inductor  $L$ , by Kirchhoff's current law, whether the turn-on inductor controls the rate of rise of current in the collector (direct snubbing) or rate of current fall in the diode (indirect snubbing), the complementary element has its current inversely controlled.

Figure 10.33 shows variations of a snubber for recovering the energy associated with freewheel diode reverse recovery. All twelve circuits have the same functional ac operating mechanism, although a number have been published – even patented - as different. US patent 5633579, 1997, according to the three claims, explicitly covers the boost converter snubber circuit in figure 10.33a. In protecting the specific boost converter circuit, all the other topological variations are inadvertently and unwittingly implicitly precluded. Although highly skilled in the art, Irving, IEEE APEC, 2002, published the next recovery circuit, figure 10.33b, as a new diode recovery snubber for the boost converter.

Passive inductive turn-on snubber energy recovery circuit variations are shown in figure 10.34, for collector and emitter connected buck, boost, forward, and buck boost converters. Six versions exist with the circuitry in each of the switch emitter and collector circuits.

Figure 10.35 shows turn-off and turn-off plus turn-on passive recovery circuit variations. The circuitry can be in the emitter or collector (as shown) circuit.

## 10.9 Snubbers for rectified outputs

Freewheel diode  $D_{fw}$  overvoltage due to leakage and stray inductance can be clamped by the active soft clamp shown in figure 10.31a. Passive clamping is complicated by the fact that the bridge side voltage of the inductor switches at source voltage levels with a variable duty cycle, while the inductor output voltage is clamp to the switched voltage average. The concept of activating the snubber discharge switch using an auxiliary winding on the main transformer or on the filter inductor is elegantly covered by patent US 6,771,521 (2004). The gate controlling winding  $L_{o2}$  can be auto-transformer coupled to the output inductor  $L_{o1}$  or can be an extra winding on the converter main transformer. The use of an n-channel mosfet for  $T_s$ , with its parasitic antiparallel diode, avoids the need for the discrete snubber diode  $D_s$ . Figure 10.31b shows the gate winding coupled to the output filter inductor, plus resonant reset components, where an optional transformer catch winding can be coupled to the output  $C_o$  or the converter input. The patent is specific to a rectifier so is free to be exploited across a switch. (See 19.9.2) An RCD soft snubber (resistor replacing  $T_s$ , connected either end of  $L_o$ ), is the simplest (loss) approach.

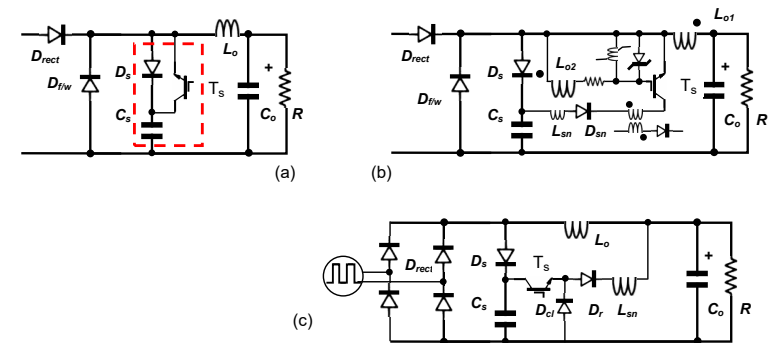

Figure 10.31. Active rectifier snubber (a) basic concept, (b) gating circuitry, and (c) for full-wave rectifier.

## Reading list

- Williams, B. W., et al., 'Passive snubber energy recovery for a GTO thyristor inverter bridge leg', *Trans. IE IEEE*, Vol. 47, No. 1, Feb. (2000) pp. 2-8.
- Williams, B. W., 'High-voltage high-frequency power-switching transistor module with switching-aid-circuit energy recovery', *Proc. IEE, Part B*, Vol. 131, No. 1, (1984) pp. 7-12.
- Finney, S. J. et al., 'High-power GTO thyristor chopper applications with passive snubber energy recovery', *Proc. IEE, EPA*, Vol. 144, No. 6, (1997) pp. 381-388.

## Problems

- 10.1. For the circuit in Figure 10.14a show that the upper current limit for total energy recovery is given by  $\frac{1}{2}L_s I_m^2 \leq \frac{1}{2}C_s V_s^2$ .
- 10.2. Derive capacitor  $C_s$  voltage and current equations which describe the operation of the turn-off snubber energy recovery circuit in figure 10.13. Assume the storage capacitor  $C_s$  to be an ideal voltage source with polarity as shown.

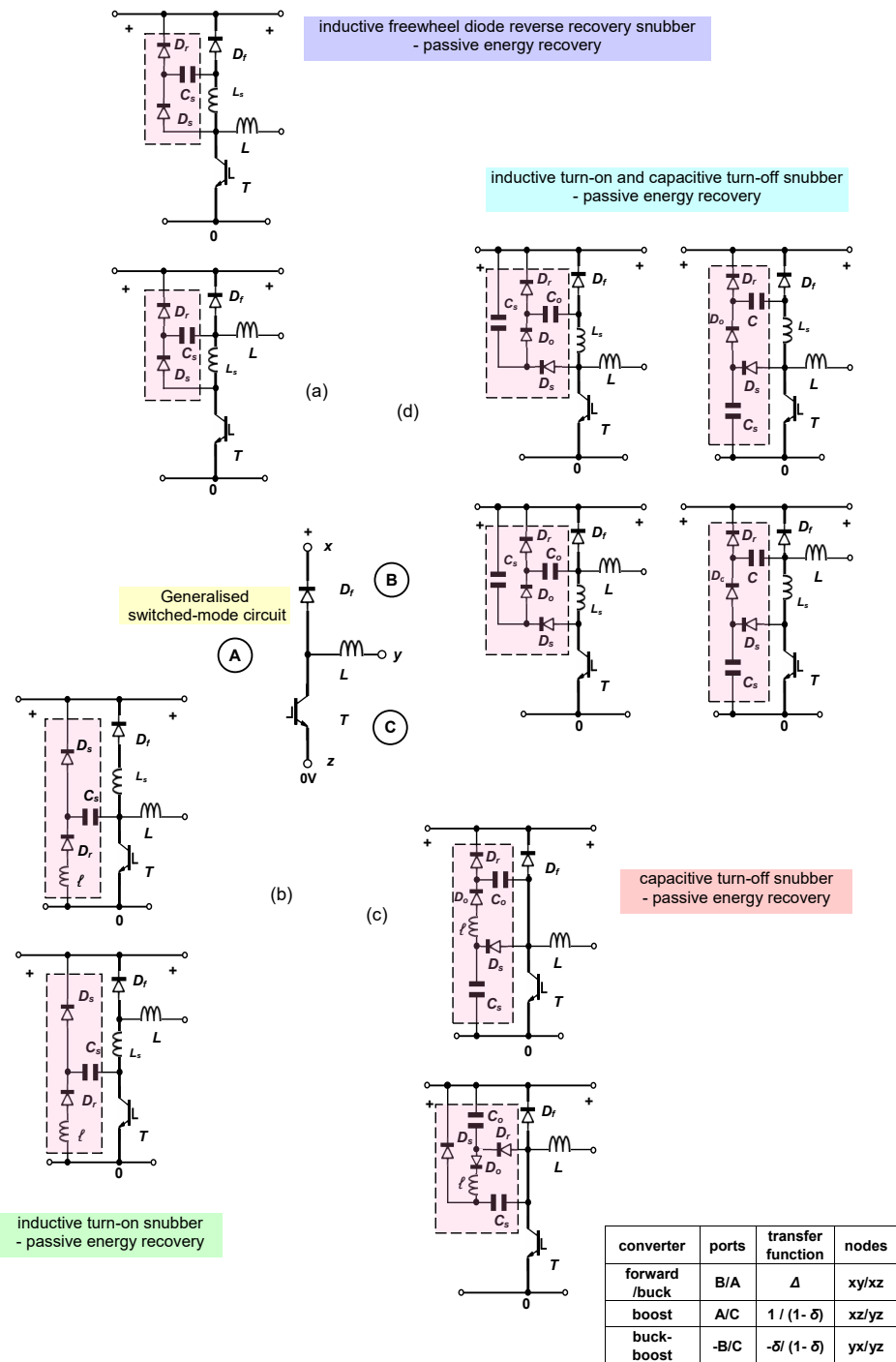

Figure 10.32. Snubber energy recovery circuits for generalised switch-diode-inductive element circuit.

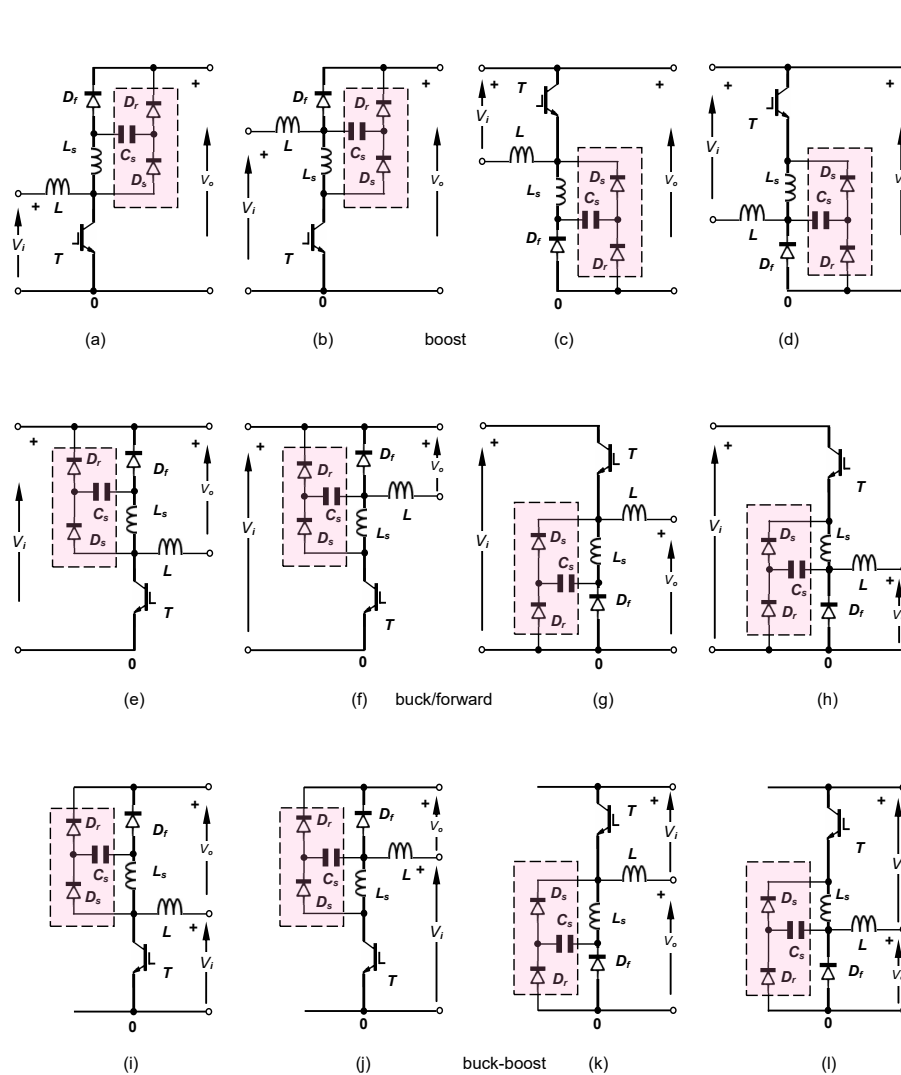

Figure 10.33. Passive energy recovery of freewheel diode recovery energy: (a)-(d) a boost converter; (e)-(h) a buck/forward converter; and (i)-(l) a buck-boost converter.

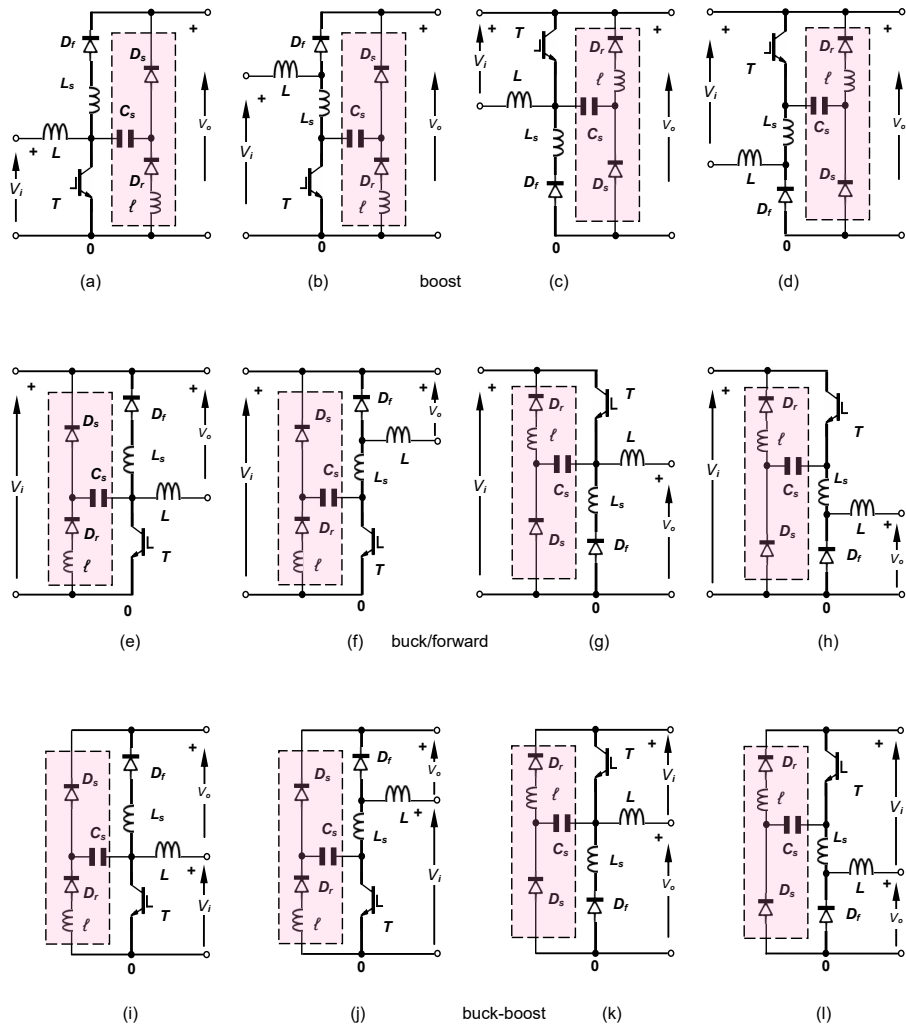

Figure 10.34. Passive energy recovery for inductive turn-on snubber: (a)-(d) a boost converter; (e)-(h) a buck/forward converter; and (i)-(l) a buck-boost converter.

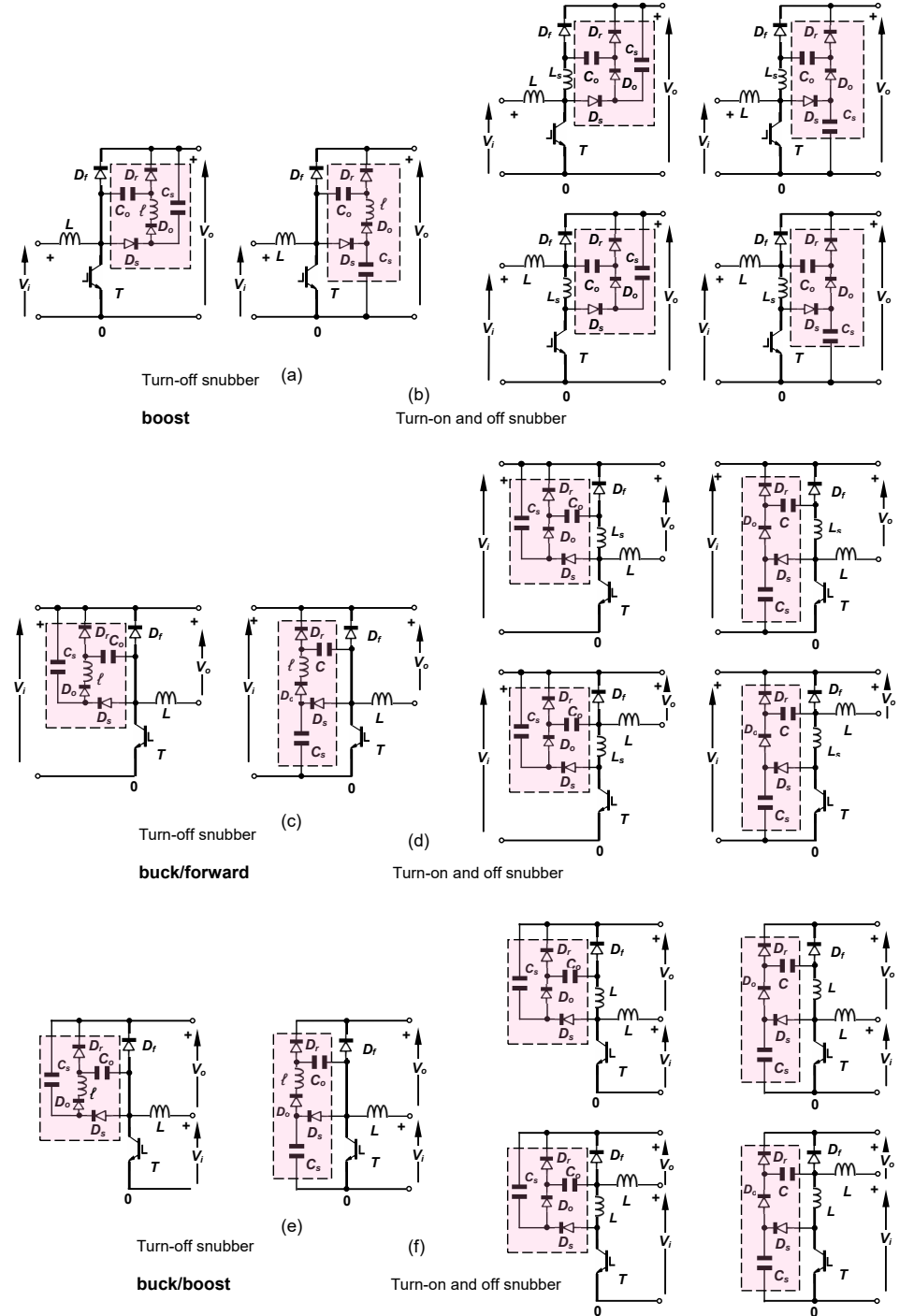

Figure 10.35. Passive energy recovery circuits for the capacitive turn-off snubber and both turn-on and turn-off snubber circuits, for the different types of switched mode converters.